



Deep Security 20 Guide

for On-Premises Installations

Legal notices

Trend Micro Incorporated reserves the right to make changes to this document and to the products described herein without notice. Before installing and using the software, please review the release notes and the latest version of the applicable user documentation, which are available from the Trend Micro Web site at:

<https://help.deepsecurity.trendmicro.com/software.html>

Trend Micro, and the Trend Micro t-ball logo are trademarks or registered trademarks of Trend Micro Incorporated. All other company or product names may be trademarks or registered trademarks of their owners. Information contained in this document is subject to change without notice.

© 2024 Trend Micro Incorporated. All rights reserved

Protected by U.S. Patent No. 7,630,982 B2.

Privacy Policy

Trend Micro, Inc. is committed to protecting your privacy. Please read the Trend Micro Privacy Policy available at www.trendmicro.com.

Document Number: APEM209012/200622

Publication Date: 5/2/2024 10:04 AM

Contents

Legal notices	2
Contents	3
About Deep Security	104
Deep Security 20 release strategy and life cycle policy	104
Supported upgrade paths	104
Deep Security 20 update schedule	105
LTS release support duration and upgrade best practices	105
Support services	107
Agent platform support policy	108
Deep Security life cycle dates	109
Deep Security LTS life cycle dates	109
Deep Security LTS release life cycle dates	110
Deep Security Virtual Appliance release life cycle dates	111
Support extensions	111
Archive of past support extensions	115
Deep Security FR life cycle dates	116
Deep Security FR release life cycle dates	117
Support extensions	118
About the Deep Security components	119
About the Deep Security protection modules	119
Intrusion Prevention	120
Anti-Malware	120
Firewall	120
Web Reputation	121
Integrity Monitoring	121
Log Inspection	121

Application Control	121
Device Control	122
About this release	122
What's new?	122
What's new in Deep Security Manager?	122
Deep Security Manager - 20.0.904 (20 LTS Update 2024-04-17)	122
New Features	123
Enhancements	123
Resolved issues	123
Deep Security Manager - 20.0.893 (20 LTS Update 2024-03-20)	123
Enhancements	124
Resolved issues	124
Deep Security Manager - 20.0.883 (20 LTS Update 2024-02-21)	124
New Features	124
Enhancements	124
Resolved issues	124
Deep Security Manager - 20.0.879 (20 LTS Update 2024-01-17)	125
New Features	125
Enhancements	125
Resolved issues	125
Known issues	126
Security updates	126
Deep Security Manager - 20.0.864 (20 LTS Update 2023-12-12)	126
Enhancements	126
Resolved issues	127
Known issues	127
Deep Security Manager - 20.0.854 (20 LTS Update 2023-11-15)	127
New Features	127
Enhancements	127

Resolved issues	128
Security updates	128
Known issues	128
Deep Security Manager - 20.0.844 (20 LTS Update 2023-10-18)	128
New Features	128
Enhancements	128
Resolved issues	129
Known issues	129
Deep Security Manager - 20.0.833 (20 LTS Update 2023-09-20)	129
Enhancements	129
Resolved issues	130
Security updates	130
Deep Security Manager - 20.0.817 (20 LTS Update 2023-08-23)	131
Enhancements	131
Deep Security Manager - 20.0.802 (20 LTS Update 2023-07-19)	131
Enhancements	131
Resolved issues	131
Security updates	131
Deep Security Manager - 20.0.789 (20 LTS Update 2023-06-28)	132
New Features	132
Enhancements	132
Resolved issues	132
Security updates	132
Deep Security Manager - 20.0.768 (20 LTS Update 2023-05-17)	133
New Features	133
Resolved issues	133
Deep Security Manager - 20.0.759 (20 LTS Update 2023-04-19)	133
Enhancements	133
Resolved issues	133

Deep Security Manager - 20.0.741 (20 LTS Update 2023-03-15)	134
New Features	134
Deep Security Manager - 20.0.737 (20 LTS Update 2023-02-23)	134
Enhancements	134
Security updates	134
Deep Security Manager - 20.0.725 (20 LTS Update 2023-01-18)	135
Resolved issues	135
Security updates	135
Deep Security Manager - 20.0.716 (20 LTS Update 2022-12-15)	135
Resolved issues	135
Deep Security Manager - 20.0.711 (20 LTS Update 2022-11-16)	136
Enhancements	136
Security updates	136
Deep Security Manager - 20.0.703 (20 LTS Update 2022-10-19)	136
Enhancements	136
Resolved issues	137
Deep Security Manager - 20.0.686 (20 LTS Update 2022-09-21)	137
Resolved issues	137
Deep Security Manager - 20.0.677 (20 LTS Update 2022-08-17)	137
New Features	138
Enhancements	138
Resolved issues	138
Deep Security Manager - 20.0.664 (20 LTS Update 2022-07-21)	138
Enhancements	138
Resolved issues	139
Security updates	139
Deep Security Manager - 20.0.651 (20 LTS Update 2022-06-15)	139
Enhancements	139
Deep Security Manager - 20.0.644 (20 LTS Update 2022-05-18)	139

Resolved issues	140
Security updates	140
Deep Security Manager - 20.0.635 (20 LTS Update 2022-04-21)	140
New Features	140
Resolved issues	141
Deep Security Manager - 20.0.619 (20 LTS Update 2022-03-22)	141
New Features	141
Enhancements	141
Resolved issues	142
Security updates	142
Deep Security Manager - 20.0.605 (20 LTS Update 2022-02-16)	142
Enhancements	142
Resolved issues	143
Security updates	143
Deep Security Manager - 20.0.585 (20 LTS Update 2022-01-17)	143
New Features	143
Enhancements	143
Resolved issues	144
Security updates	144
Deep Security Manager - 20.0.560 (20 LTS Update 2021-12-16)	144
New Features	144
Resolved issues	145
Security updates	145
Deep Security Manager - 20.0.543 (20 LTS Update 2021-11-18)	145
Enhancements	145
Resolved issues	146
Deep Security Manager - 20.0.513 (20 LTS Update 2021-10-14)	147
New Feature	147
Resolved issues	147

Deep Security Manager - 20.0.503 (20 LTS Update 2021-09-23)	147
New Feature	147
Enhancements	148
Resolved issues	148
Security updates	149
Deep Security Manager - 20.0.482 (20 LTS Update 2021-08-25)	149
Enhancements	149
Resolved issues	149
Security updates	150
Deep Security Manager - 20.0.463 (20 LTS Update 2021-07-22)	150
Enhancements	150
Resolved issues	151
Security updates	151
Deep Security Manager - 20.0.447 (20 LTS Update 2021-06-28)	151
New Feature	151
Enhancements	152
Resolved issues	152
Security updates	153
Deep Security Manager - 20.0.414 (20 LTS Update 2021-05-24)	153
Enhancement	153
Resolved issues	153
Deep Security Manager - 20.0.393 (20 LTS Update 2021-04-27)	154
Enhancements	154
Resolved issues	154
Security updates	155
Deep Security Manager - 20.0.366 (20 LTS Update 2021-03-24)	156
New Feature	156
Enhancements	156
Resolved issues	156

Security updates	156
Deep Security Manager - 20.0.344 (20 LTS Update 2021-02-23)	157
Enhancements	157
Resolved issues	157
Deep Security Manager - 20.0.321 (20 LTS Update 2021-01-26)	158
Enhancements	158
Resolved issues	158
Security updates	158
Deep Security Manager - 20.0.313 (20 LTS Update 2021-01-18)	158
New Feature	159
Enhancements	159
Resolved issues	159
Security updates	160
Deep Security Manager - 20.0.262 (20 LTS Update 2020-11-26)	160
New Features	161
Enhancements	161
Resolved issues	161
Security updates	161
Deep Security Manager 20.0.198 (20 LTS Update 2020-10-19)	162
Enhancements	162
Resolved issues	162
Security updates	162
Deep Security Manager 20.0.174 (20 LTS Update 2020-09-16)	162
New features	163
Improved management and quality	163
Enhancements	163
Resolved issues	164
Security updates	164
Notices	164

Deep Security Manager 20 (long-term support release)	165
Action required if you use cross-account roles to add AWS accounts to Deep Security using the API /rest/cloudaccounts/aws	165
New features	165
Updated platform support	165
Improved Security	166
Improved management and quality	166
Enhancements	168
Resolved issues	172
Security updates	175
Known issues	176
What's new in Deep Security Agent?	177
Deep Security Agent - 20.0.1-7380 (20 LTS Update 2024-04-24)	177
New features	177
Enhancements	177
Resolved issues	177
Deep Security Agent - 20.0.1-4540 (20 LTS Update 2024-03-20)	178
New features	178
Enhancements	178
Resolved issues	179
Known issues	179
Deep Security Agent - 20.0.1-3180 (20 LTS Update 2024-02-29)	179
Enhancements	179
Resolved issues	179
Security updates	180
Known issues	180
Deep Security Agent - 20.0.1-690 (20 LTS Update 2024-01-17)	180
New features	181
Enhancements	181

Resolved issues	181
Known issues	181
Deep Security Agent - 20.0.0-8453 (20 LTS Update 2024-01-17)	182
Resolved issues	182
Enhancements	182
Known issues	183
Deep Security Agent - 20.0.0-8438 (20 LTS Update 2023-12-12)	183
New features	183
Enhancements	183
Resolved issues	183
Security updates	184
Known issues	184
Deep Security Agent - 20.0.0-8268 (20 LTS Update 2023-11-21)	184
New Features	185
Resolved issues	185
Known issues	185
Deep Security Agent - 20.0.0-8137 (20 LTS Update 2023-10-26)	186
New features	186
Known issues	186
Deep Security Agent - 20.0.0-7943 (20 LTS Update 2023-09-26)	186
New features	187
Enhancements	187
Resolved issues	188
Known issues	188
Deep Security Agent - 20.0.0-7719 (20 LTS Update 2023-08-29)	188
New features	189
Enhancements	189
Resolved issues	189
Deep Security Agent - 20.0.0-7476 (20 LTS Update 2023-07-25)	189

Enhancements	190
Resolved issues	190
Deep Security Agent - 20.0.0-7303 (20 LTS Update 2023-06-28)	190
New features	190
Enhancements	191
Resolved issues	191
Deep Security Agent - 20.0.0-7119 (20 LTS Update 2023-05-29)	191
Enhancements	192
Resolved issues	192
Deep Security Agent - 20.0.0-6912 (20 LTS Update 2023-05-02)	192
New features	193
Enhancements	193
Resolved issues	193
Deep Security Agent - 20.0.0-6658 (20 LTS Update 2023-03-22)	194
New features	194
Enhancements	194
Resolved issues	196
Deep Security Agent - 20.0.0-6313 (20 LTS Update 2023-01-31)	197
New feature	197
Enhancements	197
Resolved issues	198
Known issues	199
Deep Security Agent - 20.0.0-5953 (20 LTS Update 2022-11-22)	199
New feature	199
Enhancements	199
Resolved issues	199
Known issues	200
Deep Security Agent - 20.0.0-5761 (20 LTS Update 2022-10-21)	200
New feature	200

Enhanced platform support	200
Enhancements	200
Resolved issues	201
Deep Security Agent - 20.0.0-5512 (20 LTS Update 2022-09-22)	201
Enhancements	201
Resolved issues	202
Security updates	202
Known issues	202
Deep Security Agent - 20.0.0-5394 (20 LTS Update 2022-08-29)	203
New features	203
Enhancements	203
Resolved issues	203
Known issues	204
Deep Security Agent - 20.0.0-5137 (20 LTS Update 2022-07-26)	204
New features	204
Enhancements	205
Resolved issues	205
Security updates	205
Known issues	206
Deep Security Agent - 20.0.0-4959 (20 LTS Update 2022-07-04)	206
New features	206
Enhancements	206
Resolved issues	206
Deep Security Agent - 20.0.0-4726 (20 LTS Update 2022-05-31)	207
Enhancements	207
Resolved issues	208
Security updates	208
Deep Security Agent - 20.0.0-4416 (20 LTS Update 2022-04-28)	209
Enhancements	209

Resolved issues	209
Security updates	209
Deep Security Agent - 20.0.0-4185 (20 LTS Update 2022-04-06)	209
New features	209
Resolved issues	210
Deep Security Agent - 20.0.0-3964 (20 LTS Update 2022-03-01)	210
New features	210
Enhanced platform support	210
Enhancements	211
Resolved issues	211
Deep Security Agent - 20.0.0-3770 (20 LTS Update 2022-01-24)	211
New features	211
Enhancements	211
Resolved issues	212
Security updates	212
Deep Security Agent - 20.0.0-3445 (20 LTS Update 2021-11-24)	212
New features	213
Enhancements	213
Resolved issues	213
Security updates	214
Deep Security Agent - 20.0.0-3288 (20 LTS Update 2021-10-28)	214
New features	214
Enhanced platform support	215
Enhancements	215
Resolved issues	215
Security updates	216
Deep Security Agent - 20.0.0-3165 (20 LTS Update 2021-10-08)	216
New features	216
Enhancements	217

Resolved issues	217
Security updates	217
Deep Security Agent - 20.0.0-2971 (20 LTS Update 2021-09-08)	218
New features	218
Enhancements	218
Resolved issues	218
Security updates	220
Deep Security Agent - 20.0.0-2593 (20 LTS Update 2021-07-01)	220
New feature	220
Resolved issues	220
Security updates	220
Deep Security Agent - 20.0.0-2395 (20 LTS Update 2021-05-24)	221
New features	221
Enhanced platform support	221
Enhancements	221
Resolved issues	222
Deep Security Agent - 20.0.0-2204 (20 LTS Update 2021-04-12)	222
New feature	222
Enhanced platform support	222
Resolved issues	223
Deep Security Agent - 20.0.0-2009 (20 LTS Update 2021-03-08)	223
Enhancements	223
Resolved issues	223
Deep Security Agent - 20.0.0-1876 (20 LTS Update 2021-02-08)	224
Resolved issues	224
Deep Security Agent - 20.0.0-1822 (20 LTS Update 2021-01-18)	224
New features	224
Enhanced platform support	224
Deep Security Agent - 20.0.0-1681 (20 LTS Update 2021-01-04)	224

Resolved issues	225
Deep Security Agent 20.0.0-1559 (20 LTS Update 2020-12-07)	225
New features	225
Enhancements	225
Resolved issues	226
Notice	226
Deep Security Agent 20.0.0-1337 (20 LTS Update 2020-10-28)	227
Resolved issues	227
Deep Security Agent 20.0.0-1304 (20 LTS Update 2020-10-21)	227
Enhancements	227
Resolved issues	227
Action required: Customers participating in the Trend Micro XDR Activity Monitoring preview for Workload Security	228
Deep Security Agent 20.0.0-1194 (20 LTS Update 2020-10-05)	228
New features	228
Enhancements	229
Resolved issues	229
Security updates	230
Deep Security Agent 20 (long-term support release)	231
New features	231
Enhanced platform support	231
Improved security	231
Improved management and quality	232
Enhancements	233
Resolved issues	235
Security updates	238
Kernel support	238
Known issues	238
Deep Security Agent - 20.0.1-7380 (20 LTS Update 2024-04-24)	239

Enhancements	239
Resolved issues	239
Deep Security Agent - 20.0.1-4540 (20 LTS Update 2024-03-20)	239
Enhancements	240
Resolved issues	240
Deep Security Agent - 20.0.1-3180 (20 LTS Update 2024-02-29)	240
New features	240
Enhancements	240
Resolved issues	241
Security updates	241
Known issues	241
Deep Security Agent - 20.0.1-700 (20 LTS Update 2024-04-17)	242
Enhancements	242
Known issues	242
Deep Security Agent - 20.0.1-690 (20 LTS Update 2024-01-17)	242
New features	242
Enhancements	243
Resolved issues	243
Security updates	243
Known issues	243
Deep Security Agent - 20.0.0-8438 (20 LTS Update 2023-12-12)	244
New features	244
Enhancements	244
Resolved issues	244
Security updates	245
Known issues	245
Deep Security Agent - 20.0.0-8268 (20 LTS Update 2023-11-21)	245
Resolved issues	245
Known issues	246

Deep Security Agent - 20.0.0-8137 (20 LTS Update 2023-10-26)	246
New features	246
Resolved issues	246
Known issues	246
Deep Security Agent - 20.0.0-7943 (20 LTS Update 2023-09-26)	247
Enhancements	247
Resolved issues	247
Deep Security Agent - 20.0.0-7719 (20 LTS Update 2023-08-29)	247
New features	247
Enhancements	247
Resolved issues	248
Security updates	248
Deep Security Agent - 20.0.0-7476 (20 LTS Update 2023-07-25)	249
New features	249
Enhancements	249
Resolved issues	249
Deep Security Agent - 20.0.0-7303 (20 LTS Update 2023-06-28)	250
Enhancements	250
Resolved issues	250
Deep Security Agent - 20.0.0-7119 (20 LTS Update 2023-05-29)	251
Enhancements	251
Resolved issues	251
Known issues	252
Deep Security Agent - 20.0.0-6860 (20 LTS Update 2023-04-25)	252
Enhancements	252
Resolved issues	253
Security updates	253
Deep Security Agent - 20.0.0-6690 (20 LTS Update 2023-03-29)	253
New features	254

Enhancements	254
Resolved issues	255
Known issues	256
Deep Security Agent - 20.0.0-6313 (20 LTS Update 2023-01-31)	256
New features	256
Enhancements	257
Resolved issues	257
Deep Security Agent - 20.0.0-5995 (20 LTS Update 2022-11-28)	258
New features	258
Enhancements	258
Resolved issues	258
Deep Security Agent - 20.0.0-5810 (20 LTS Update 2022-10-27)	259
New features	259
Enhancements	260
Resolved issues	260
Known issues	261
Deep Security Agent - 20.0.0-5512 (20 LTS Update 2022-09-22)	261
Enhancements	261
Resolved issues	261
Security updates	262
Known issues	262
Deep Security Agent - 20.0.0-5394 (20 LTS Update 2022-08-29)	262
Enhancements	262
Resolved issues	263
Known issues	263
Deep Security Agent - 20.0.0-5137 (20 LTS Update 2022-07-26)	264
New features	264
Enhancements	264
Resolved issues	264

Security updates	265
Known issues	265
Deep Security Agent - 20.0.0-4959 (20 LTS Update 2022-07-04)	265
Resolved issues	266
Security updates	266
Deep Security Agent - 20.0.0-4726 (20 LTS Update 2022-05-31)	267
Enhancements	267
Resolved issues	267
Security updates	267
Deep Security Agent - 20.0.0-4416 (20 LTS Update 2022-04-28)	268
Enhancements	268
Resolved issues	268
Security updates	269
Deep Security Agent - 20.0.0-4185 (20 LTS Update 2022-04-06)	269
New features	269
Enhancements	269
Resolved issues	270
Deep Security Agent - 20.0.0-3964 (20 LTS Update 2022-03-01)	270
New features	270
Enhancements	270
Resolved issues	270
Deep Security Agent - 20.0.0-3771 (20 LTS Update 2022-01-24)	271
New features	271
Enhancements	271
Resolved issues	271
Security updates	272
Deep Security Agent - 20.0.0-3530 (20 LTS Update 2021-12-15)	272
New features	272
Important Notes	273

Resolved issues	273
Deep Security Agent - 20.0.0-3445 (20 LTS Update 2021-11-24)	273
New features	273
Enhancements	274
Resolved issues	274
Security updates	275
Deep Security Agent - 20.0.0-3288 (20 LTS Update 2021-10-28)	275
New features	275
Resolved issues	276
Security updates	276
Deep Security Agent - 20.0.0-3165 (20 LTS Update 2021-10-08)	276
New features	277
Resolved issues	277
Security updates	277
Deep Security Agent - 20.0.0-2921 (20 LTS Update 2021-08-30)	278
New features	278
Enhancements	278
Resolved issues	278
Security updates	278
Deep Security Agent - 20.0.0-2740 (20 LTS Update 2021-07-29)	279
Enhancements	279
Resolved issues	279
Security updates	279
Deep Security Agent - 20.0.0-2593 (20 LTS Update 2021-07-01)	280
Resolved issues	280
Security updates	280
Deep Security Agent - 20.0.0-2419 (20 LTS Update 2021-06-02)	281
Resolved issues	281
Deep Security Agent - 20.0.0-2204 (20 LTS Update 2021-04-12)	281

Resolved issues	281
Deep Security Agent - 20.0.0-2009 (20 LTS Update 2021-03-08)	282
Enhancements	282
Resolved issues	282
Deep Security Agent - 20.0.0-1876 (20 LTS Update 2021-02-08)	282
Resolved issues	283
Deep Security Agent - 20.0.0-1822 (20 LTS Update 2021-01-18)	283
Resolved issues	283
Deep Security Agent - 20.0.0-1681 (20 LTS Update 2021-01-04)	283
Deep Security Agent 20.0.0-1559 (20 LTS Update 2020-12-07)	283
New features	283
Enhanced platform support	283
Improved security	284
Enhancements	284
Resolved issues	284
Notice	284
Deep Security Agent 20.0.0-1337 (20 LTS Update 2020-10-28)	285
New features	285
Enhancements	285
Resolved issues	285
Security updates	286
Action required: Customers participating in the Trend Micro XDR Activity Monitoring preview for Workload Security	286
Known issues	287
Deep Security Agent 20 (long-term support release)	287
New features	287
Improved security	287
Improved quality and management	288
Enhancements	289

Resolved issues	289
Security updates	292
Known issues	292
Upgrade notice	292
Deep Security Agent - 20.0.1-7380 (20 LTS Update 2024-04-24)	293
Enhancements	293
Resolved issues	293
Deep Security Agent - 20.0.1-4540 (20 LTS Update 2024-03-20)	293
Deep Security Agent - 20.0.1-3180 (20 LTS Update 2024-02-29)	293
Resolved issues	293
Security updates	294
Known issues	294
Deep Security Agent - 20.0.1-690 (20 LTS Update 2024-01-17)	294
Enhancements	294
Resolved issues	295
Known issues	295
Deep Security Agent - 20.0.0-8438 (20 LTS Update 2023-12-12)	295
Resolved issues	295
Security updates	295
Known issues	296
Deep Security Agent - 20.0.0-8268 (20 LTS Update 2023-11-21)	296
Resolved issues	296
Deep Security Agent - 20.0.0-8137 (20 LTS Update 2023-10-26)	296
Deep Security Agent - 20.0.0-7943 (20 LTS Update 2023-09-26)	296
Enhancements	297
Deep Security Agent - 20.0.0-7719 (20 LTS Update 2023-08-29)	297
Enhancements	297
Resolved issues	297
Deep Security Agent - 20.0.0-7476 (20 LTS Update 2023-07-25)	298

Enhancements	298
Resolved issues	298
Deep Security Agent - 20.0.0-7303 (20 LTS Update 2023-06-28)	298
Enhancements	298
Resolved issues	299
Deep Security Agent - 20.0.0-7119 (20 LTS Update 2023-05-29)	299
Enhancements	299
Resolved issues	299
Deep Security Agent - 20.0.0-6912 (20 LTS Update 2023-05-02)	299
Enhancements	300
Resolved issues	300
Deep Security Agent - 20.0.0-6658 (20 LTS Update 2023-03-22)	300
New features	300
Enhancements	300
Resolved issues	301
Deep Security Agent - 20.0.0-6313 (20 LTS Update 2023-01-31)	302
Enhancements	302
Resolved issues	302
Deep Security Agent - 20.0.0-5953 (20 LTS Update 2022-11-22)	303
Deep Security Agent - 20.0.0-5761 (20 LTS Update 2022-10-21)	303
Enhancements	303
Resolved issues	303
Deep Security Agent - 20.0.0-5512 (20 LTS Update 2022-09-22)	304
Enhancements	304
Resolved issues	304
Security updates	304
Deep Security Agent - 20.0.0-5394 (20 LTS Update 2022-08-29)	304
New features	304
Enhancements	305

Resolved issues	305
Known issues	305
Deep Security Agent - 20.0.0-5137 (20 LTS Update 2022-07-26)	305
Enhancements	306
Resolved issues	306
Security updates	306
Known issues	306
Deep Security Agent - 20.0.0-4959 (20 LTS Update 2022-07-04)	306
Resolved issues	307
Deep Security Agent - 20.0.0-4726 (20 LTS Update 2022-05-31)	307
Resolved issues	307
Security updates	307
Deep Security Agent - 20.0.0-4416 (20 LTS Update 2022-04-28)	308
Enhancements	308
Resolved issues	308
Security updates	308
Deep Security Agent - 20.0.0-4185 (20 LTS Update 2022-04-06)	308
Resolved issues	309
Deep Security Agent - 20.0.0-3964 (20 LTS Update 2022-03-01)	309
New features	309
Enhancements	309
Deep Security Agent - 20.0.0-3770 (20 LTS Update 2022-01-24)	309
Enhancements	309
Resolved issues	310
Security updates	310
Deep Security Agent - 20.0.0-3445 (20 LTS Update 2021-11-24)	310
Enhancements	310
Resolved issues	310
Security updates	311

Deep Security Agent - 20.0.0-3288 (20 LTS Update 2021-10-28)	311
New features	311
Resolved issues	312
Security updates	312
Deep Security Agent - 20.0.0-3165 (20 LTS Update 2021-10-08)	312
New features	312
Resolved issues	313
Security updates	313
Deep Security Agent - 20.0.0-2921 (20 LTS Update 2021-08-30)	313
Resolved issues	313
Deep Security Agent - 20.0.0-2740 (20 LTS Update 2021-07-29)	314
Enhancements	314
Resolved issues	314
Security updates	314
Deep Security Agent - 20.0.0-2593 (20 LTS Update 2021-07-01)	315
Resolved issues	315
Security updates	315
Deep Security Agent - 20.0.0-2395 (20 LTS Update 2021-05-24)	315
Enhancement	316
Resolved issues	316
Deep Security Agent - 20.0.0-2204 (20 LTS Update 2021-04-12)	316
New feature	316
Enhanced platform support	316
Resolved issues	316
Deep Security Agent - 20.0.0-2009 (20 LTS Update 2021-03-08)	316
Resolved issues	317
Deep Security Agent - 20.0.0-1876 (20 LTS Update 2021-02-08)	317
Resolved issues	317
Deep Security Agent - 20.0.0-1822 (20 LTS Update 2021-01-18)	317

New feature	317
Deep Security Agent - 20.0.0-1681 (20 LTS Update 2021-01-04)	317
Deep Security Agent 20.0.0-1559 (20 LTS Update 2020-12-07)	317
New features	318
Enhancements	318
Resolved issues	318
Notice	318
Deep Security Agent 20.0.0-1337 (20 LTS Update 2020-10-28)	319
Resolved issues	319
Deep Security Agent 20.0.0-1304 (20 LTS Update 2020-10-21)	319
Enhancements	319
Resolved issues	320
Deep Security Agent 20.0.0-1194 (20 LTS Update 2020-10-05)	320
Enhancements	320
Resolved issues	320
Security updates	320
Deep Security Agent 20 (long-term support release)	321
New features	321
Improved security	321
Improved quality and management	321
Enhancements	322
Resolved issues	323
Security updates	326
What's new in Deep Security Virtual Appliance?	326
New features	327
Improved security	327
Improved management and quality	327
Enhancements	327
Resolves issues	328

Known issues	328
Compatibility	329
System requirements	329
Deep Security Manager requirements	329
Deep Security Agent requirements	332
Deep Security Relay requirements	333
Deep Security Virtual Appliance requirements	334
Agent requirements	336
Agent platform compatibility	336
Minor Linux version compatibility	343
Docker compatibility	343
Linux kernel compatibility	349
Disable optional Linux kernel support package updates	350
Disable kernel support package updates on one computer	350
Disable kernel support package updates on multiple computers	350
Linux file system compatibility	350
Linux systemd support	351
Linux Secure Boot support	356
SELinux support	358
Supported features by platform	360
AIX	360
AlmaLinux	363
Amazon Linux	364
CentOS Linux	366
CloudLinux	368
Debian Linux	368
Miracle Linux	371
Oracle Linux	372
Red Hat Enterprise Linux	374

Red Hat OpenShift	377
Rocky Linux	377
Solaris	379
SUSE Linux	379
Ubuntu Linux	382
Microsoft Windows	385
Deep Security Virtual Appliance 20 (NSX) supported guest operating systems	395
Sizing	401
Deep Security Manager sizing	402
Multiple server nodes	402
Database sizing	403
Database disk space estimates	404
Deep Security Agent and Relay sizing	405
Estimated Agent resource consumption	405
Windows Agent	406
Linux Agent	406
Deep Security Virtual Appliance sizing	407
Deep Security Manager performance features	409
Performance profiles	409
Low disk space alerts	410
Low disk space on the database	410
Low disk space on the manager	410
Port numbers, URLs, and IP addresses	410
Deep Security port numbers	411
Deep Security URLs	416
Get Started	427
Check digital signatures on software packages	427
Check the signature on software ZIP packages	427
Check the signature on installer files (EXE, MSI, RPM or DEB files)	429

Check the signature on an EXE or MSI file	430
Check the signature on an RPM file	430
Check the signature on a DEB file	432
Deploy Deep Security Manager	434
Prepare a database	434
Database requirements	434
Software requirements	435
Microsoft SQL Server Express considerations	436
Hardware requirements	436
Network requirements	436
VMware requirements	437
Scaling requirements	437
Install a database server	437
Configure the database	437
Basic configuration	438
Multi-tenancy configuration	438
Optional PostgreSQL tuning	438
Basic configuration	439
Multi-tenancy configuration	439
Basic configuration	439
Oracle RAC configuration	440
Multi-tenancy configuration	440
Run a readiness check	441
Install Deep Security Manager	442
Before you begin	442
Install the manager	443
Test the installation (log in to the manager)	446
Replace the self-signed certificate	446
Install Deep Security Manager silently	447

Before you begin	447
Run a silent install on Windows	447
Run a silent install on Linux	448
Silent install parameters	448
Sample installation output	449
Successful install	450
Failed install	451
Deep Security settings in the properties file	451
Required Settings	451
LicenseScreen	451
CredentialsScreen	452
Optional Settings	452
LanguageScreen	452
UpgradeVerificationScreen	452
OldDataMigrationScreen	452
DatabaseScreen	453
AddressAndPortsScreen	455
CredentialsScreen	456
MasterKeyConfigurationScreen	456
SecurityUpdateScreen	457
SoftwareUpdateScreen	457
SmartProtectionNetworkScreen	458
RelayScreen	459
Sample properties file	460
Add activation codes	461
Set up multi-tenancy	461
Set up a multi-tenant environment	461
Multi-tenancy requirements	462
Enable multi-tenancy	463

Create a tenant	463
Examples of messages sent to tenants	465
Email Confirmation Link: Account Confirmation Request	465
Email Generated Password	465
Scalability guidelines	465
Multi-tenancy tips	466
Reconnaissance IP list	466
Use multiple database servers	466
Tenant pending deletion state	466
Multi-tenant options under System Settings	466
Managing tenants	467
Tenant Properties	467
General	467
Modules	467
Features	468
Statistics	468
Agent Activation	468
What does the tenant see?	468
Agent-Initiated Activation	470
Tenant diagnostics	470
Usage monitoring	470
Multi-tenant Dashboard	471
Multi-tenant reports	471
Security Module Usage Cumulative Report	471
Security Module Usage Report	472
Tenant Report	472
Configure database user accounts	473
Configuring database user accounts	473
SQL Server	474

Oracle	477
PostgreSQL	480
Configuring multiple database servers	481
Removing or changing secondary databases	481
APIs	481
Upgrade a multi-tenant environment	482
Supporting tenants	483
Multi-tenancy with Deep Security Virtual Appliance	483
Multi-tenant settings	484
Database servers	486
New tenant template	486
Protection usage monitoring	488
Set up multiple nodes	488
Install Deep Security Manager on multiple nodes	488
Set up a load balancer	489
Configure the load balancer in Deep Security	489
Add a node	490
Remove a node	491
Upgrade a node	491
Viewing node statuses	491
Network Map with Activity Graph	491
Jobs by Node	492
Jobs by Type	493
Total jobs by node and type	493
View active Deep Security Manager nodes	494
Deploy Deep Security Relay	496
Deploy Deep Security Agent	497
Get Deep Security Agent software	497
View agent software available for download	498

View a list of imported agent software	498
Import agent software	499
Import agent software directly, from the Download Center	499
Import agent software indirectly, from the Help Center	500
Import agent software updates automatically	500
Export the agent installer	501
Solaris-version-to-agent-package mapping table	502
AIX agent package naming format	502
Delete a software package from the Deep Security database	503
Deleting agent packages in single-tenancy mode	503
Deleting agent packages in multi-tenancy mode	503
Deleting kernel support packages	504
Configure Linux Secure Boot for agents	504
Download the Trend Micro public keys	505
Update the Trend Micro public key	506
Enroll a Secure Boot key for AWS	508
Enroll a Secure Boot key for Google Cloud Platform	511
Enroll a Secure Boot key for VMware vSphere platform	512
Enroll a Secure Boot key for physical computers	513
Enroll a Secure Boot key for Oracle Linux	515
Install the agent	515
Install the agent manually	515
Installation on Amazon WorkSpaces	517
Installation on Windows 2012 Server Core	517
Install the agent using other methods	521
Post-installation tasks	522
Install the agent on Amazon EC2 and WorkSpaces	522
Add your AWS accounts to Deep Security Manager	523
Set the communication direction	523

Configure the activation type	524
Open ports	525
Which ports should be opened?	525
Deploy agents to your Amazon EC2 instances and WorkSpaces	526
Verify that the agent was installed and activated properly	527
Assign a policy	527
Install the agent on an AMI or WorkSpace bundle	528
Add your AWS account to Deep Security Manager	528
Set the communication direction	529
Configure the activation type	529
Launch a 'master' Amazon EC2 instance or Amazon WorkSpace	529
Deploy an agent on the master	529
Verify that the agent was installed and activated properly	530
(Recommended) Set up policy auto-assignment	530
Create an AMI or custom WorkSpace bundle based on the master	531
Use the AMI	531
Install the agent on Azure VMs	532
Install the agent on Google Cloud Platform VMs	532
Install the agent on VMware vCloud	535
Create a minimum rights role for vCloud account tenant users	535
Assign unique UUIDs to new virtual machines	536
Enable the OVF Environment Transport for VMware Tools on your guest VMs	536
Import computers from a VMware vCloud Organization account	536
Import computers from a VMware vCloud Air Virtual data center	537
Activate the agent	538
Deactivate the agent	539
Start or stop the agent	540
Common issues when installing or updating the agent	540
1. Anti-Malware engine offline (Windows)	541

2. Security update failed	541
3. Performance/Application issues introduced after installing the Deep Security Agent (Anti-Malware and Module Isolation)	542
Deploy Deep Security Virtual Appliance	544
Protection for VMware environments	544
Deep Security Virtual Appliance features	544
Scan caching	544
Scan storm optimization	545
Ease of management	545
VMware deployments with the virtual appliance and NSX	545
VMware deployments with the agent only	547
Additional information	547
Choose agentless vs. combined mode protection	548
Agentless protection	548
Combined mode	548
Conversion of coordinated approach to combined mode	549
Choose an agent or appliance for each protection feature	549
Enable combined mode in a vCloud Director environment with agent-initiated activation	550
Before deploying the appliance	551
Review system requirements	551
Install or upgrade NSX, Deep Security Manager and other components	551
Re-register NSX-T	551
Set up communication	552
(Optional) Install Deep Security Agents	552
(Optional) Configure high-availability	553
Next steps	553
Configure VMware DRS	553
Deploy the appliance (NSX-T 3.x)	554
Import the appliance	554

Prepare Fabric settings	555
Configure the User Interface Mode Toggle	555
Configure a Compute Manager	556
Configure a Transport Zone	557
Configure a Transport Node Profile	558
Prepare the host	562
Create a logical switch	564
Add vCenter to Deep Security Manager	566
Install the appliance on NSX-T 3.x	567
Begin the service deployment	567
Configure and start the service deployment	568
Set the Service Deployment Name	568
Set the Compute Manager	568
Set the Cluster	568
Set the Data Store	568
Set the Networks	568
Set the Deployment Specification	569
Set the Service Segment	570
Set the Deployment template	571
Monitor and verify the deployment	571
Monitor the deployment in NSX-T 3.x	572
Monitor the deployment in vSphere Client	572
Verify the deployment in Deep Security Manager	573
Repeat all steps for each cluster	573
Create a group for protection	573
Configure east-west security	575
Add a service profile	575
Add a service chain	576
Add a Network Introspection policy	577

Connect VMs to the logical switch	578
Configure Endpoint Protection	579
Configure activation	581
Prepare for activation	581
Method 1: Create a 'Computer Created' event-based task	582
Method 2: Create an 'NSX Security Group Change' event-based task	583
Method 3: Synchronize your Deep Security policies to NSX-T 3.x	586
Trigger an activation and policy assignment	588
Check that VMs are activated and assigned a policy	588
Next steps (how to add new VMs)	588
Deploy the appliance (NSX-V)	589
Step 1: Import the appliance package into Deep Security Manager	589
Step 2: Add vCenter to Deep Security Manager	590
Step 3: Prepare ESXi servers	590
Step 4: Install Guest Introspection	592
Step 5: Install the Deep Security Virtual Appliance on NSX-V	595
Step 6: Create an NSX security group and policy	596
Step 7: Prepare for activation on NSX-V	604
Method 1: Create a 'Computer Created' event-based task	605
Method 2: Create an 'NSX Security Group Change' event-based task	606
Method 3: Synchronize your Deep Security policies to NSX-V	609
Step 8: Trigger an activation and policy assignment	611
Step 9: Check that VMs are activated and assigned a policy	611
Next steps (how to add new VMs)	611
Deploy the appliance in a vCloud environment	612
Before you begin	612
Enable agentless protection of vCloud VMs	612
Create a multi-tenant environment	612
Add a vCenter and deploy the Deep Security Virtual Appliance	613

Configure VMware vCloud resources for integration with Deep Security	613
Create a minimum rights role for vCloud account tenant users	613
Assign unique UUIDs to new virtual machines	614
Enable the OVF Environment Transport for VMware Tools on your guest VMs	614
Activate virtual appliance protection on virtual machines	614
Import computers from a VMware vCloud Organization Account	615
Import computers from a VMware vCloud Air Virtual data center	615
Activate virtual appliance protection on virtual machines	616
Automated policy management in NSX environments	616
"NSX Security Group Change" event-based task	617
Conditions under which to perform tasks	617
Available actions	618
Event-based tasks created when adding a vCenter to Deep Security Manager	619
Removal of a vCenter from Deep Security Manager	620
Synchronize Deep Security policies with NSX	621
Configure DPDK mode	622
Configure NSX security tags	624
Configure Anti-Malware to apply NSX security tags	624
Configure Intrusion Prevention to apply NSX security tags	625
Configure the appliance OVF location	626
Deep Security Virtual Appliance memory allocation	628
Configure the appliance's memory allocation prior to deployment to the vCenter	628
Configure the memory allocation of an already-deployed appliance	629
Start or stop the appliance	630
Deploy Deep Security notifier	630
Copy the Installation Package	630
Install the Deep Security notifier for Windows	631
User Guide	631
Add computers	631

About adding computers	631
Add computers to the manager	632
Group computers	632
Export your computers list	632
Delete a computer	633
Add local network computers	633
Agent-initiated activation	633
Manually add a computer	633
Discover computers	634
Add Active Directory computers	636
Additional Active Directory options	637
Remove Directory	637
Synchronize Now	637
Server certificate usage	638
Import users and contacts	638
Keep Active Directory objects synchronized	639
Disable Active Directory synchronization	640
Remove computer groups from Active Directory synchronization	640
Delete Active Directory users and contacts	640
Add AWS instances	640
About adding AWS accounts	640
Overview of methods for adding AWS accounts	641
What happens when you add an AWS account?	641
What are the benefits of adding an AWS account?	641
What AWS regions are supported?	642
Add an AWS account using a manager instance role	642
Add an AWS account using an access key	646
Add an AWS account using a cross-account role	649
Add the account through the API	653

Add Amazon WorkSpaces	654
Protect Amazon WorkSpaces if you already added your AWS account	654
Protect Amazon WorkSpaces if you have not yet added your AWS account	655
Manage an AWS account	655
Edit an AWS account	655
Remove an AWS account	656
Synchronize an AWS account	656
Manage an AWS account external ID	656
What is the external ID?	657
Configure the external ID	657
Update the external ID	657
Retrieve the external ID	659
Disable retrieval of the external ID	659
Manage AWS regions	660
Add an Amazon Web Services region	660
Viewing your Amazon Web Services regions	660
Removing an Amazon Web Services region	661
Protect an account running in AWS Outposts	661
Add Azure instances	662
Create an Azure app for Deep Security	662
Assign the correct roles	662
Create the Azure app	662
Record the Azure app ID and Active Directory ID	663
Create an application secret or upload the application certificate	663
Option 1: Create client secrets (application password)	663
Option 2: Upload an application certificate	664
Record the Subscription ID(s)	664
Assign the Azure app a role and connector	664
Add a Microsoft Azure account to Deep Security	665

What are the benefits of adding an Azure account?	665
Configure a proxy setting for the Azure account	666
Add virtual machines from a Microsoft Azure account to Deep Security	666
Manage Azure classic virtual machines with the Azure Resource Manager connector	667
Remove an Azure account	667
Synchronize an Azure account	668
Why should I upgrade to the new Azure Resource Manager connection functionality?	668
Add GCP instances	669
Create a Google Cloud Platform service account	669
Prerequisite: Enable the Google APIs	669
Create a GCP service account	670
Add more projects to the GCP service account	674
Create multiple GCP service accounts	677
Add a Google Cloud Platform account	677
What are the benefits of adding a GCP account?	678
Configure a proxy setting for the GCP account	678
Add a GCP account to Deep Security	678
Remove a GCP account	680
Synchronize a GCP account	681
Add VMWare VMs	681
Add a VMware vCenter	681
Add a vCenter	682
vCenter user account specifications	683
NSX user account specifications	685
Add multiple vCenters	686
Add a vCenter - FIPS mode	686
Add virtual machines hosted on VMware vCloud	687
What are the benefits of adding a vCloud account?	688

Proxy setting for cloud accounts	688
Create a VMware vCloud Organization account for the manager	688
Import computers from a VMware vCloud Organization Account	689
Import computers from a VMware vCloud Air data center	690
Configure software updates for cloud accounts	690
Remove a cloud account	691
Change IP address or FQDN of NSX Manager	691
Add an ESXi to a protected NSX cluster	691
How do I migrate to the new cloud connector functionality?	692
Protect Docker containers	693
Deep Security protection for the Docker host	694
Deep Security protection for Docker containers	695
Limitation on Intrusion Prevention recommendation scans	695
Protect OpenShift containers	695
Deep Security protection for the OpenShift host	696
Deep Security protection for OpenShift containers	696
Configure policies	696
Create policies	696
Create a new policy	697
Other ways to create a policy	697
Edit the settings for a policy or individual computer	698
Assign a policy to a computer	699
Disable automatic policy updates	699
Send policy changes manually	700
Export a policy	700
Policies, inheritance, and overrides	701
Inheritance	701
Overrides	703
Override object properties	703

Override rule assignments	704
View the overrides on a computer or policy at a glance	704
Manage and run recommendation scans	705
What gets scanned?	706
Scan limitations	707
Adobe Reader rules recommendation	708
Run a recommendation scan	708
Create a scheduled task to regularly run recommendation scans	709
Configure an ongoing scan	710
Manually run a recommendation scan	710
Cancel a recommendation scan	710
Exclude a rule or application type from recommendation scans	710
Automatically implement recommendations	711
Check scan results and manually assign rules	712
Configure recommended rules	713
Implement additional rules for common vulnerabilities	713
Troubleshooting: Recommendation Scan Failure	715
Communication	715
Server resources	715
Timeout values	715
Detect and configure the interfaces available on a computer	716
Configure a policy for multiple interfaces	716
Enforce interface isolation	717
Overview section of the computer editor	717
General tab	718
Computer status	719
Protection module status	719
VMware virtual machine summary	721
Actions tab	721

Activation	721
Policy	721
Agent Software	721
Support	722
TPM tab	722
System Events tab	723
Exceptions tab	723
USB Device Exception rule count limitation	723
Overview section of the policy editor	723
General tab	723
General	723
Inheritance	724
Modules	724
Computer(s) Using This Policy tab	724
Events tab	724
Exceptions tab	724
USB Device Exception rule count limitation	724
Network engine settings	725
Define rules, lists, and other common objects used by policies	735
About common objects	735
Rules	735
Lists	736
Other	736
Create a firewall rule	736
Add a new rule	737
Select the behavior and protocol of the rule	737
Select a Packet Source and Packet Destination	739
Configure rule events and alerts	741
Alerts	741

Set a schedule for the rule	741
Assign a context to the rule	741
See policies and computers a rule is assigned to	741
Export a rule	742
Delete a rule	742
Configure intrusion prevention rules	742
See the list of intrusion prevention rules	743
See information about an intrusion prevention rule	743
General Information	743
Details	743
See the list of intrusion prevention rules	744
General Information	744
Identification (Trend Micro rules only)	745
See information about the associated vulnerability (Trend Micro rules only)	745
Assign and unassign rules	745
Automatically assign updated required rules	746
Configure event logging for rules	746
Generate alerts	747
Setting configuration options (Trend Micro rules only)	747
Schedule active times	748
Exclude from recommendations	749
Set the context for a rule	749
Override the behavior mode for a rule	749
Override rule and application type configurations	750
Export and import rules	751
Create an Integrity Monitoring rule	751
Add a new rule	752
Enter Integrity Monitoring rule information	752
Select a rule template and define rule attributes	752

Registry Value template	752
File template	753
Custom (XML) template	753
Configure Trend Micro Integrity Monitoring rules	753
Configure rule events and alerts	754
Real-time event monitoring	754
Alerts	754
See policies and computers a rule is assigned to	755
Export a rule	755
Delete a rule	755
Define a Log Inspection rule for use in policies	755
Create a new Log Inspection rule	756
Decoders	758
Subrules	759
Groups	759
Rules, ID, and Level	760
Description	761
Decoded As	761
Match	762
Conditional Statements	763
Hierarchy of Evaluation	763
Restrictions on the Size of the Log Entry	764
Composite Rules	765
Real world examples	767
Log Inspection rule severity levels and their recommended use	775
strftime() conversion specifiers	776
Examine a Log Inspection rule	777
Log Inspection rule structure and the event matching process	777
Duplicate Sub-rules	780

Create a list of directories for use in policies	781
Import and export directory lists	783
See which policies use a directory list	783
Create a list of file extensions for use in policies	783
Import and export file extension lists	784
See which malware scan configurations use a file extension list	784
Create a list of files for use in policies	784
Import and export file lists	787
See which policies use a file list	787
Create a list of IP addresses for use in policies	788
Import and export IP lists	788
See which rules use an IP list	788
Create a list of ports for use in policies	789
Import and export port lists	789
See which rules use a port list	789
Create a list of MAC addresses for use in policies	790
Import and export MAC lists	790
See which policies use a MAC list	790
Define contexts for use in policies	790
Configure settings used to determine whether a computer has internet connectivity	791
Define a context	791
Define stateful firewall configurations	792
Add a stateful configuration	792
Enter stateful configuration information	793
Select packet inspection options	793
IP packet inspection	793
TCP packet inspection	794
FTP Options	795
UDP packet inspection	795

ICMP packet inspection	796
Export a stateful configuration	796
Delete a stateful configuration	797
See policies and computers a stateful configuration is assigned to	797
Define a schedule that you can apply to rules	797
Configure protection modules	798
Configure Anti-Malware	798
About Anti-Malware	798
Types of malware scans	799
Real-time scan	799
Manual scan	799
Scheduled scan	799
Quick scan	800
Scan objects and sequence	800
Malware scan configurations	800
Malware events	801
SmartScan	801
Predictive Machine Learning	802
Threat Intelligence	802
Malware types	802
Virus	802
Trojans	803
Packer	803
Spyware/grayware	804
Cookie	805
Other threats	805
Possible malware	805
Set up Anti-Malware	805
Enable and configure anti-malware	805

Turn on the anti-malware module	806
Select the types of scans to perform	806
Configure scan exclusions	806
Ensure that Deep Security can keep up to date on the latest threats	807
Configure malware scans and exclusions	808
Create or modify a malware scan configuration	808
Test malware scans	809
Scan for specific types of malware	810
Enable Windows AMSI protection (real-time scans only)	810
Scan for spyware and grayware	811
Scan for compressed executable files (real-time scans only)	811
Scan process memory (real-time scans only)	811
Scan compressed files	812
Scan embedded Microsoft Office objects	812
Enable a manual scan for the notifier application on Windows OS	812
Enable a manual scan on Linux OS	813
Specify the files to scan	813
Inclusions	813
Exclusions	814
Exclude directories, files, and process image files by creating a list of patterns to exclude	814
Test file exclusions	815
Syntax for directory lists	816
Syntax of file lists	817
Syntax of file extension lists	819
Syntax of process image file lists (real-time scans only)	820
Scan a network directory (real-time scan only)	820
Specify when real-time scans occur	820
Configure malware handling	820

Customize malware remedial actions	821
ActiveAction actions	822
Generate alerts for malware detection	823
Apply NSX security tags	823
Identify malware files by file hash digest	823
Configure notifications on the computer	824
Performance tips for anti-malware	825
Minimize disk usage	825
Optimize CPU usage	825
Enable multi-threaded processing	826
Optimize RAM usage	827
Coexistence of Deep Security Agent with Microsoft Defender Antivirus	827
Microsoft Defender Antivirus application files for exclusion list for DSA	828
DSA folders and processes for Microsoft Defender Antivirus exclusion list	828
Tamper protection	828
Virtual Appliance Scan Caching	829
Scan Cache Configurations	829
Malware Scan Cache Configuration	830
Integrity Monitoring Scan Cache Configuration	830
Scan Cache Settings	830
When to change the default configuration	831
Detect emerging threats using Predictive Machine Learning	832
Ensure Internet connectivity	832
Enable Predictive Machine Learning	832
Detect emerging threats using Threat Intelligence	833
How does Threat Intelligence work?	834
Check the Threat Intelligence prerequisites	835
Set up a connection to Trend Micro Vision One	835
Set up a connection to Deep Discovery Analyzer	836

Set up a connection to Trend Micro Apex Central	838
Create a malware scan configuration for use with Threat Intelligence	840
Enable Threat Intelligence for your computers	841
Manually submit a file to Sandbox Analysis	841
Allow a file that has raised a false alarm	842
Configure the scan action for a suspicious file	842
Update the suspicious objects list in Deep Security	842
Configure Threat Intelligence in a multi-tenant environment	843
Supported file types	843
Migrating from Connected Threat Defense to Threat Intelligence	844
Multi-tenant migration	845
Enhanced anti-malware and ransomware scanning with behavior monitoring	846
How does enhanced scanning protect you?	846
How to enable enhanced scanning	847
What happens when enhanced scanning finds a problem?	848
What if my agents can't connect to the Internet directly?	853
Smart Protection in Deep Security	853
Anti-malware and Smart Protection	853
Benefits of Smart Scan	853
Enable Smart Scan	854
Smart Protection Server for File Reputation Service	855
Web Reputation and Smart Protection	855
Smart Feedback	856
Handle malware	856
View and restore identified malware	856
See a list of identified files	857
Working with identified files	858
Search for an identified file	859
Restore identified files	861

Create a scan exclusion for the file	861
Restore the file	864
Manually restore identified files	864
Configure advanced exploit exceptions	864
Create an exception from an anti-malware event	865
Manually create an anti-malware exception	866
Exception List Wildcard Support	866
Exception strategies for spyware and grayware	869
Scan exclusion recommendations	869
Exclude files signed by a trusted certificate	870
Increase debug logging for anti-malware in protected Linux instances	871
Configure Web Reputation	871
Enable the web reputation module	872
Enable the Trend Micro Toolbar	872
Install the toolbar for Windows	873
Switch between inline and tap mode	873
Enforce the security level	874
To configure the security level:	874
Create exceptions	874
To create URL exceptions:	875
Configure the Smart Protection Server	876
Smart Protection Server Connection Warning	877
Edit advanced settings	877
Blocking Page	877
Alert	877
Ports	877
Test Web Reputation	877
Configure Intrusion Prevention (IPS)	878
About Intrusion Prevention	878

Intrusion Prevention rules	878
Application types	879
Rule updates	879
Recommendation scans	879
Use behavior modes to test rules	879
Override the behavior mode for rules	880
Intrusion Prevention events	881
Support for secure connections	881
Contexts	881
Interface tagging	882
Set up Intrusion Prevention	882
Enable Intrusion Prevention in Detect mode	882
Test Intrusion Prevention	884
Apply recommended rules	885
Monitor your system	886
Monitor system performance	886
Check Intrusion Prevention events	887
Enable 'fail open' for packet or system failures	887
Switch to Prevent mode	887
Implement best practices for specific rules	887
HTTP Protocol Decoding rule	887
Cross-site scripting and generic SQL injection rules	888
Apply NSX security tags	888
Configure intrusion prevention rules	888
See the list of intrusion prevention rules	889
See information about an intrusion prevention rule	889
General Information	890
Details	890
See the list of intrusion prevention rules	890

General Information	891
Identification (Trend Micro rules only)	891
See information about the associated vulnerability (Trend Micro rules only)	891
Assign and unassign rules	892
Automatically assign updated required rules	892
Configure event logging for rules	893
Generate alerts	894
Setting configuration options (Trend Micro rules only)	894
Schedule active times	894
Exclude from recommendations	895
Set the context for a rule	895
Override the behavior mode for a rule	896
Override rule and application type configurations	896
Export and import rules	897
Configure an SQL injection prevention rule	897
What is an SQL injection attack?	898
What are common characters and strings used in SQL injection attacks?	898
How does the Generic SQL Injection Prevention rule work?	900
Examples of the rule and scoring system in action	901
Example 1: Logged and dropped traffic	901
Example 2: No logged or dropped traffic	902
Configure the Generic SQL Injection Prevention rule	903
Character encoding guidelines	906
Application types	908
See a list of application types	908
General Information	909
Connection	909
Configuration	909
Options	909

Assigned To	909
Inspect TLS traffic	910
Enable Advanced TLS Traffic Inspection	910
Use Advanced TLS Traffic Inspection for inbound and outbound traffic	910
Configure SSL inspection (legacy)	911
Change port settings	912
Use Intrusion Prevention when traffic is encrypted with Perfect Forward Secrecy (PFS)	912
Special considerations for Diffie-Hellman ciphers	913
Supported cipher suites	914
Supported protocols	919
TLS inspection support	920
Manage TLS inspection support package updates	920
Disable TLS inspection support package updates on a single agent	920
Disable TLS inspection support package updates by policy	920
Configure anti-evasion settings	921
Performance tips for intrusion prevention	924
Maximum size for configuration packages	925
Configure Firewall	926
About Firewall	926
Firewall rules	926
Set up the Deep Security firewall	927
Test Firewall rules before deploying them	927
Test in Tap mode	928
Test in Inline mode	928
Enable 'fail open' behavior	929
Turn on Firewall	930
Default Firewall rules	931
Default Bypass rule for Deep Security Manager Traffic	932

Restrictive or permissive Firewall design	932
Restrictive Firewall	932
Permissive Firewall	933
Firewall rule actions	933
Firewall rule priorities	934
Allow rules	934
Force Allow rules	934
Bypass rules	935
Recommended Firewall policy rules	935
Test Firewall rules	935
Reconnaissance scans	936
Stateful inspection	937
Example	938
Important things to remember	939
Create a firewall rule	939
Add a new rule	940
Select the behavior and protocol of the rule	940
Select a Packet Source and Packet Destination	943
Configure rule events and alerts	944
Alerts	944
Set a schedule for the rule	944
Assign a context to the rule	944
See policies and computers a rule is assigned to	945
Export a rule	945
Delete a rule	945
Allow trusted traffic to bypass the firewall	945
Create a new IP list of trusted traffic sources	945
Create incoming and outbound firewall rules for trusted traffic using the IP list	946

Assign the firewall rules to a policy used by computers that trusted traffic flows through	946
Firewall rule actions and priorities	946
Firewall rule actions	947
More about Allow rules	947
More about Bypass rules	948
Default Bypass rule for Deep Security Manager traffic	948
More about Force Allow rules	949
Firewall rule sequence	949
A note on logging	951
How firewall rules work together	951
Rule Action	951
Rule priority	953
Putting rule action and priority together	953
Firewall settings	954
General	954
Firewall	954
Firewall Stateful Configurations	954
Port Scan (Computer Editor only)	955
Assigned Firewall Rules	955
Interface Isolation	956
Interface Isolation	956
Interface Patterns	956
Reconnaissance	957
Reconnaissance Scans	957
Advanced	959
Events	959
Firewall events	959
Firewall settings with Oracle RAC	959

Add a rule to allow communication between nodes	960
Add a rule to allow UDP port 42424	960
Allow other RAC-related packets	962
Ensure that the Oracle SQL Server rule is assigned	964
Ensure that anti-evasion settings are set to "Normal"	964
Define stateful firewall configurations	965
Add a stateful configuration	966
Enter stateful configuration information	966
Select packet inspection options	966
IP packet inspection	966
TCP packet inspection	967
FTP Options	968
UDP packet inspection	968
ICMP packet inspection	969
Export a stateful configuration	970
Delete a stateful configuration	970
See policies and computers a stateful configuration is assigned to	970
Scan for open ports	970
Container Firewall rules	971
Kubernetes Firewall rules	971
Swarm Firewall rules	973
Configure Device Control	974
About Device Control	974
Device Control protocols	974
Actions against device type	974
USB Autorun	974
Set up Device Control	975
Configure protocols	975
Configure USB Device Exceptions	976

Create new device	976
Select existing devices	976
Device Control event tagging	976
Configure Integrity Monitoring	977
About Integrity Monitoring	977
Set up Integrity Monitoring	977
How to enable Integrity Monitoring	977
Turn on Integrity Monitoring	978
Run a Recommendation scan	979
Apply the Integrity Monitoring rules	979
Build a baseline for the computer	981
Periodically scan for changes	981
Test Integrity Monitoring	981
When Integrity Monitoring scans are performed	982
Integrity Monitoring scan performance settings	983
Limit CPU usage	983
Change the content hash algorithm	983
Enable a VM Scan Cache configuration	984
Integrity Monitoring event tagging	984
Create an Integrity Monitoring rule	985
Add a new rule	985
Enter Integrity Monitoring rule information	986
Select a rule template and define rule attributes	986
Registry Value template	986
File template	986
Custom (XML) template	987
Configure Trend Micro Integrity Monitoring rules	987
Configure rule events and alerts	988
Real-time event monitoring	988

Alerts	988
See policies and computers a rule is assigned to	989
Export a rule	989
Delete a rule	989
Integrity Monitoring rules language	989
About the Integrity Monitoring rules language	989
Entity Sets	990
Hierarchies and wildcards	991
Syntax and concepts	992
Include tag	993
Exclude tag	994
Case sensitivity	994
Entity features	995
ANDs and ORs	996
Order of evaluation	997
Entity attributes	997
Shorthand attributes	999
onChange attribute	999
Environment variables	999
Environment variable overrides	1000
Registry values	1001
Use of ".."	1001
Best practices	1002
DirectorySet	1002
Tag Attributes	1003
Entity Set Attributes	1003
Short Hand Attributes	1004
Meaning of "Key"	1005
Sub Elements	1005

FileSet	1005
Tag Attributes	1005
Entity Set Attributes	1006
Short Hand Attributes	1007
Drives Mounted as Directories	1008
Alternate Data Streams	1008
Meaning of "Key"	1009
Sub Elements	1009
Special attributes of Include and Exclude for FileSets:	1009
GroupSet	1010
Tag Attributes	1010
Entity Set Attributes	1010
Short Hand Attributes	1010
Meaning of "Key"	1010
Include and Exclude	1011
InstalledSoftwareSet	1011
Tag Attributes	1011
Entity Set Attributes	1012
Short Hand Attributes	1012
Meaning of "Key"	1012
Sub Elements	1013
Special attributes of Include and Exclude for InstalledSoftwareSets:	1013
PortSet	1013
Tag Attributes	1014
Entity Set Attributes	1014
Meaning of "Key"	1014
IPV6	1015
Matching of the Key	1015
Sub Elements	1015

Special attributes of Include and Exclude for PortSets:	1016
ProcessSet	1017
Tag Attributes	1017
Entity Set Attributes	1017
Short Hand Attributes	1018
Meaning of "Key"	1018
Sub Elements	1018
Special attributes of Include and Exclude for ProcessSets:	1018
RegistryKeySet	1020
Tag Attributes	1020
Entity Set Attributes	1020
Short Hand Attributes	1021
Meaning of "Key"	1021
Sub Elements	1021
RegistryValueSet	1021
Tag Attributes	1021
Entity Set Attributes	1022
Short Hand Attributes	1022
Meaning of "Key"	1022
Default Value	1023
Sub Elements	1023
ServiceSet	1024
Tag Attributes	1024
Entity Set Attributes	1024
Short Hand Attributes	1025
Meaning of "Key"	1025
Sub Elements	1026
Special attributes of Include and Exclude for ServiceSets:	1026
UserSet	1026

Tag Attributes	1027
Entity Set Attributes	1027
Common Attributes	1027
Windows-only Attributes	1028
Linux, AIX, and Solaris Attributes	1028
Short Hand Attributes	1028
Meaning of "Key"	1029
Sub Elements	1029
Include and Exclude	1029
Special attributes of Include and Exclude for UserSets	1030
WQLSet	1030
Entity Set Attributes	1032
Meaning of Key	1034
Include Exclude	1035
Virtual Appliance Scan Caching	1035
Scan Cache Configurations	1035
Malware Scan Cache Configuration	1036
Integrity Monitoring Scan Cache Configuration	1037
Scan Cache Settings	1037
When to change the default configuration	1037
Configure Log Inspection	1038
About Log Inspection	1038
Set up Log Inspection	1039
Turn on the log inspection module	1039
Run a recommendation scan	1039
Apply the recommended log inspection rules	1040
Test Log Inspection	1041
Configure log inspection event forwarding and storage	1042
Define a Log Inspection rule for use in policies	1043

Create a new Log Inspection rule	1044
Decoders	1045
Subrules	1047
Groups	1047
Rules, ID, and Level	1047
Description	1049
Decoded As	1049
Match	1049
Conditional Statements	1050
Hierarchy of Evaluation	1051
Restrictions on the Size of the Log Entry	1052
Composite Rules	1053
Real world examples	1054
Log Inspection rule severity levels and their recommended use	1063
strftime() conversion specifiers	1064
Examine a Log Inspection rule	1065
Log Inspection rule structure and the event matching process	1065
Duplicate Sub-rules	1068
Configure Application Control	1069
About Application Control	1069
Key concepts	1069
How does application control work?	1070
A tour of the application control interface	1072
Application Control: Software Changes (Actions)	1072
Application Control Rulesets	1073
Security Events	1074
What does application control detect as a software change?	1074
Differences in how Deep Security Agent 10 and 11 compare files	1075
Set up Application Control	1075

Turn on Application Control	1076
Monitor new and changed software	1077
Tips for handling changes	1079
Turn on maintenance mode when making planned changes	1080
Application Control tips and considerations	1081
Verify that Application Control is enabled	1082
Monitor Application Control events	1083
Choose which Application Control events to log	1084
View Application Control event logs	1084
Interpret aggregated security events	1084
Monitor Application Control alerts	1085
View and change Application Control rulesets	1086
View Application Control rulesets	1087
Security Events	1088
Change the action for an Application Control rule	1088
Delete an individual Application Control rule	1089
Delete an Application Control ruleset	1090
Application Control Trust Entities	1090
Trust rulesets	1091
Create a trust ruleset	1091
Assign or unassign a trust ruleset	1093
Delete a trust ruleset	1095
Trust rules	1096
Types of trust rules	1096
Create a trust rule	1097
Change trust rule properties	1099
Delete a trust rule	1101
Types of trust rule properties	1101
Process Name	1102

Paths	1102
SHA-256	1103
Vendor	1103
Product Name	1104
Signer Name	1104
Issuer Common Name	1105
Issuer Organizational Unit	1105
Issuer Organization	1105
Issuer Locality	1106
Issuer State or Province	1106
Issuer Country	1107
Application Control event aggregation and analysis	1107
Drift events	1107
Trust rules for drift events	1108
Security events	1110
Trust rules for security events	1111
Event analysis output	1113
Debug trust rules	1114
Consult metrics	1114
View signer information	1117
Trust rule property limitations for Linux	1117
Reset Application Control after too much software change	1118
Use the API to create shared and global rulesets	1119
Create a shared ruleset	1121
Change from shared to computer-specific allow and block rules	1122
Deploy Application Control shared rulesets via relays	1123
Single tenant deployments	1123
Multi-tenant deployments	1124
Considerations when using relays with shared rulesets	1124

Configure events and alerts	1125
About Deep Security event logging	1125
Where are event logs on the agent?	1125
When are events sent to the manager?	1125
How long are events stored?	1126
System events	1126
Security events	1126
See the events associated with a policy or computer	1127
View details about an event	1127
Filter the list to search for an event	1128
Export events	1129
Improve logging performance	1129
Log and event storage best practices	1129
Troubleshooting	1131
Limit log file sizes	1131
Event logging tips	1133
Anti-Malware scan failures and cancellations	1133
Anti-Malware scan failure events	1133
Anti-Malware scan cancellation events	1135
Apply tags to identify and group events	1136
Manual tagging	1137
Auto-tagging	1137
Set the precedence for an auto-tagging rule	1138
Auto-tagging log inspection events	1138
Trusted source tagging	1139
Local trusted computer	1140
How does Deep Security determine whether an event on a target computer matches an event on a trusted source computer?	1140
Tag events based on a local trusted computer	1140

Tag events based on the Trend Micro Certified Safe Software Service	1141
Tag events based on a trusted common baseline	1141
Delete a tag	1142
Reduce the number of logged events	1143
Rank events to quantify their importance	1145
Web Reputation event risk values	1145
Firewall rule severity values	1145
Intrusion Prevention rule severity values	1145
Integrity Monitoring rule severity values	1146
Log Inspection rule severity values	1146
Asset values	1146
Forward events to a Syslog or SIEM server	1146
Forward Deep Security events to a Syslog or SIEM server	1146
Allow event forwarding network traffic	1147
Request a client certificate	1147
Define a Syslog configuration	1147
Forward system events	1150
Forward security events	1151
Troubleshoot event forwarding	1151
"Failed to Send Syslog Message" alert	1151
Can't edit Syslog configurations	1152
Can't see the Syslog configuration sections of Deep Security Manager	1152
Syslog not transferred due to an expired certificate	1152
Syslog not delivered due to an expired or changed server certificate	1152
Compatibility	1152
Syslog message formats	1153
CEF syslog message format	1153
LEEF 2.0 syslog message format	1156
Events originating in the manager	1156

System event log format	1156
Events originating in the agent	1158
Anti-Malware event format	1158
Application Control event format	1176
Firewall event log format	1184
Integrity Monitoring log event format	1189
Intrusion Prevention event log format	1193
Log Inspection event format	1203
Web Reputation event format	1206
Device Control event format	1209
Configure Red Hat Enterprise Linux to receive event logs	1211
Set up a Syslog on Red Hat Enterprise Linux 8	1211
Set up a Syslog on Red Hat Enterprise Linux 6 or 7	1212
Set up a Syslog on Red Hat Enterprise Linux 5	1213
Access events with Amazon SNS	1214
Set up Amazon SNS	1214
Create an AWS user	1214
Create an Amazon SNS topic	1215
Enable SNS	1215
Create subscriptions	1216
SNS configuration in JSON format	1216
Version	1216
Statement	1216
Topic	1217
Condition	1217
Bool	1218
Exists	1218
IpAddress	1219
NotIpAddress	1220

NumericEquals	1220
NumericNotEquals	1221
NumericGreaterThan	1222
NumericGreaterThanEquals	1223
NumericLessThan	1223
NumericLessThanEquals	1224
StringEquals	1225
StringNotEquals	1226
StringEqualsIgnoreCase	1226
StringNotEqualsIgnoreCase	1226
StringLike	1227
StringNotLike	1227
Multiple statements vs. multiple conditions	1228
Multiple statements	1229
Multiple conditions	1229
Example SNS configurations	1230
Send all critical intrusion prevention events to an SNS topic	1230
Send different events to different SNS topics	1231
Events in JSON format	1232
Valid event properties	1232
Data types of event properties	1258
Example events in JSON format	1259
System event	1259
Anti-Malware events	1260
Forward system events to a remote computer via SNMP	1263
Configure alerts	1263
View alerts in Deep Security Manager	1264
Configure alert settings	1264
Set up email notification for alerts	1265

Turn alert emails on or off	1266
Configure an individual user to receive alert emails	1268
Configure recipients for all alert emails	1269
Configure SMTP settings for email notifications	1269
Generate reports about alerts and other activity	1270
Set up a single report	1270
Set up a scheduled report	1273
Lists of events and alerts	1274
Predefined alerts	1274
Agent events	1292
System events	1298
Application Control events	1349
What information is displayed for Application Control events?	1349
List of all Application Control events	1350
Anti-malware events	1350
What information is displayed for anti-malware events?	1350
List of all anti-malware events	1351
Device Control events	1352
What information is displayed for Device Control events?	1352
Firewall events	1353
What information is displayed for firewall events?	1353
List of all firewall events	1355
Intrusion prevention events	1361
What information is displayed for intrusion prevention events?	1362
View additional Intrusion Prevention event information	1363
List of all intrusion prevention events	1364
Integrity monitoring events	1367
What information is displayed for integrity monitoring events?	1367
List of all integrity monitoring events	1368

Log inspection events	1371
What information is displayed for log inspection events?	1371
List of log inspection security events	1372
Web reputation events	1372
What information is displayed for web reputation events?	1372
Add a URL to the list of allowed URLs	1373
Troubleshoot common events, alerts, and errors	1373
Why am I seeing firewall events when the firewall module is off?	1373
Troubleshoot event ID 771 "Contact by Unrecognized Client"	1373
Uninstall Deep Security Agent	1374
Reactivate the computer or clone	1374
Fix interrupted VMware connector synchronization	1374
Troubleshoot "Smart Protection Server disconnected" errors	1374
Check the error details	1374
Is the issue on a Deep Security Virtual Appliance?	1375
Error: Activation Failed	1375
Protocol Error	1375
Agent-initiated communication	1376
Bidirectional communication	1376
Unable to resolve hostname	1376
No agent/appliance	1376
Blocked port	1376
Duplicate Computer	1378
Endpoint behind proxy	1378
Reinstallation required	1378
Error: Agent version not supported	1378
Error: Anti-Malware Engine Offline	1379
Agent-based protection	1379
If your agent is on Windows:	1380

If your agent is on Linux:	1380
Agentless protection	1381
Error: Device Control Engine Offline	1381
If your agent is on Windows	1382
Error: Check Status Failed	1382
Error: Installation of Feature 'dpi' failed: Not available: Filter	1383
Additional information	1383
Error: Integrity Monitoring Engine Offline and other errors occur after activating a virtual machine	1384
Error: Interface out of sync	1384
Check the interfaces on the VM	1385
Check the VM's interface information in vCenter	1385
Check the vmx file and the VM's interface information in Deep Security Manager	1386
Check the VM's interface information in the Deep Security Virtual Appliance	1386
Workaround Options	1387
Option 1	1387
Option 2	1387
Option 3	1387
Further Troubleshooting	1387
Error: Intrusion Prevention Rule Compilation Failed	1388
Apply Intrusion Prevention best practices	1389
Manage rules	1389
Unassign application types from a single port	1390
Error: Log Inspection Rules Require Log Files	1390
If the file's location is required:	1391
If the files listed do not exist on the protected machine:	1391
Error: Module installation failed (Linux)	1391
Error: There are one or more application type conflicts on this computer	1392
Resolution	1393

Consolidate ports	1393
Disable the inherit option	1393
Error: Unable to connect to the cloud account	1394
Your AWS account access key ID or secret access key is invalid	1394
The incorrect AWS IAM policy has been applied to the account being used by Deep Security	1394
NAT, proxy, or firewall ports are not open, or settings are incorrect	1395
Error: Unable to resolve instance hostname	1395
Alert: Integrity Monitoring information collection has been delayed	1395
Alert: Manager Time Out of Sync	1396
Alert: The memory warning threshold of Manager Node has been exceeded	1396
Event: Max TCP connections	1397
Warning: Anti-Malware Engine has only Basic Functions	1397
Basic functions	1398
Reason IDs	1399
Warning: Census, Good File Reputation, and Predictive Machine Learning Service Disconnected	1400
Cause 1: The agent or relay-enabled agent doesn't have Internet access	1401
Cause 2: A proxy was enabled but not configured properly	1401
Warning: Insufficient disk space	1402
Tips	1402
Warning: Reconnaissance Detected	1402
Types of reconnaissance scans	1403
Suggested actions	1403
Configure proxies	1404
Configure proxies	1404
Register a proxy in the manager	1405
Supported proxy protocols	1405
Connect to the Primary Security Update Source via proxy	1406
Connect to Deep Security Manager via proxy	1407

Connect to Deep Security Relays via proxy	1408
Connect to Deep Security Software Updates, CSSS, and more via proxy	1409
Connect to cloud accounts via proxy	1410
Connect to Deep Discovery Analyzer via proxy	1410
Connect to Apex Central via proxy	1410
Connect to the Smart Protection Network via proxy	1411
Connect to Workload Security via proxy	1412
Remove a proxy	1412
Proxy settings	1413
Proxy server use	1413
Configure relays	1413
How relays work	1413
Relay hierarchy, cost, and performance	1415
Deploy additional relays	1415
Plan the best number and location of relays	1416
Geographic region and distance	1417
Network architecture and bandwidth limits	1417
Air-gapped environments	1418
Configure the update source	1418
Configure relays	1420
Create relay groups	1420
Enable relays	1421
Assign agents to a relay group	1422
Connect agents to a relay's private IP address	1423
Remove relay functionality from an agent	1423
Manage agents (protected computers)	1424
Computer and agent statuses	1424
Status column - computer states	1424
Status column - agent or appliance states	1425

Task(s) column	1426
Computer errors	1430
Protection module status	1431
Perform other actions on your computers	1432
Computers icons	1436
Status information for different types of computers	1438
Ordinary computer	1438
Relay	1439
Deep Security Scanner	1439
Docker, Podman, and CRI-O hosts	1440
ESXi server	1440
Virtual appliance	1441
Virtual machine with agentless protection	1441
Configure agent version control	1442
Set up agent version control	1442
Use agent version control with URL requests	1444
Agent version control FAQs	1444
Configure teamed NICs	1447
Windows	1447
Solaris	1447
Agent-manager communication	1448
Configure the heartbeat	1448
Configure communication directionality	1450
Supported cipher suites for agent-manager communication	1452
Deep Security Agent 9.6 cipher suites	1452
Deep Security Agent 10.0 cipher suites	1452
Deep Security Agent 11.0, 12.0, and 20 cipher suites	1453
Configure agents that have no internet access	1453
Solutions	1454

Use a proxy	1454
Install a Smart Protection Server locally	1454
Get updates in an isolated network	1455
Get rules updates in an isolated network	1458
Disable the features that use Trend Micro security services	1458
Activate and protect agents using agent-initiated activation and communication	1460
Enable agent-initiated activation and communication	1461
Create or modify policies with agent-initiated communication enabled	1461
Enable agent-initiated activation	1461
Assign the policy to agents	1462
Use a deployment script to activate the agents	1462
Automatically upgrade agents on activation	1462
Enable automatic agent upgrade	1463
Check that agents were upgraded successfully	1463
Using Deep Security with iptables	1465
Rules required by Deep Security Manager	1465
Rules required by Deep Security Agent	1465
Prevent Deep Security from automatically adding iptables rules	1466
Enable or disable agent self-protection on Windows	1466
Configure self-protection through Deep Security Manager	1467
Configure agent self-protection using the command line	1467
Enable or disable agent self-protection on Linux	1468
Configure self-protection through Deep Security Manager	1468
Configure self-protection using the command line	1469
Limitations	1469
Troubleshooting	1470
Are "Offline" agents still protected by Deep Security?	1470
Automate offline computer removal with inactive agent cleanup	1470
Enable inactive agent cleanup	1471

Ensure computers that are offline for extended periods of time remain protected with Deep Security	1471
Set an override to prevent specific computers from being removed	1472
Check the audit trail for computers removed by an inactive cleanup job	1472
Search system events	1472
System event details	1473
2953 - Inactive Agent Cleanup Completed Successfully	1473
251 - Computer Deleted	1473
716 - Reactivation Attempted by Unknown Agent	1473
Agent settings	1474
Hostnames	1474
Agent-initiated activation (AIA)	1474
Agent Upgrade	1476
Inactive Agent Cleanup	1477
Data Privacy	1477
Agentless vCloud Protection	1477
Deep Security notifier	1478
How the notifier works	1478
Trigger a manual scan on Windows OS	1482
Manage users	1483
Add and manage users	1483
Synchronize users with an Active Directory	1483
Add or edit an individual user	1484
Change a user's password	1487
Lock out a user or reset a lockout	1487
View system events associated with a user	1487
Delete a user	1487
Define roles for users	1488
Add or edit a role	1489

Default settings for full access, auditor, and new roles	1496
Add users who can only receive reports	1504
Add or edit a contact	1504
Delete a contact	1505
Create an API key for a user	1505
Lock out an existing API key	1505
Unlock a locked out user name	1506
Unlock users as an administrator	1506
Unlock administrative users from a command line	1506
Implement SAML single sign-on (SSO)	1507
About SAML single sign-on (SSO)	1507
What are SAML and single sign-on?	1507
How SAML single sign-on works in Deep Security	1507
Establishing a trust relationship	1507
Creating Deep Security accounts from user identities	1507
Implement SAML single sign-on in Deep Security	1508
Configure SAML single sign-on	1509
Configure pre-set up requirements	1509
Configure Deep Security as a SAML service provider	1510
Configure SAML in Deep Security	1511
Import your identity provider's SAML metadata document	1511
Create Deep Security roles for SAML users	1511
Provide information for your identity provider administrator	1511
Download the Deep Security Manager service provider SAML metadata document	1511
Send URNs and the Deep Security SAML metadata document to the identity provider administrator	1511
SAML claims structure	1512
Deep Security user name (required)	1512
Sample SAML data (abbreviated)	1512

Deep Security user role (required)	1513
Sample SAML data (abbreviated)	1513
Maximum session duration (optional)	1513
Sample SAML data (abbreviated)	1514
Preferred language (optional)	1514
Sample SAML data (abbreviated)	1514
Test SAML single sign-on	1515
Review the set-up	1515
Create a Diagnostic Package	1515
Service and identity provider settings	1515
Configure SAML single sign-on with Microsoft Entra ID	1515
Who is involved in this process?	1516
Configure Deep Security as a SAML service provider	1516
Download the Deep Security service provider SAML metadata document	1517
Configure Microsoft Entra ID	1517
Configure SAML in Deep Security	1518
Import the Microsoft Entra ID metadata document	1518
Create Deep Security roles for SAML users	1518
Get URNs	1519
Define a role in Microsoft Entra ID	1519
Service and identity provider settings	1519
SAML claims structure	1519
Deep Security user name (required)	1520
Sample SAML data (abbreviated)	1520
Deep Security user role (required)	1520
Sample SAML data (abbreviated)	1521
Maximum session duration (optional)	1521
Sample SAML data (abbreviated)	1521
Preferred language (optional)	1522

Sample SAML data (abbreviated)	1522
Manage the database	1522
General database maintenance	1522
Maintain PostgreSQL	1523
Log rotation	1524
Example: Daily Database Log Rotation	1524
Lock management	1525
Maximum concurrent connections	1525
Effective cache size	1525
Shared buffers	1525
Work memory and maintenance work memory	1526
Checkpoints	1526
Write-ahead log (WAL)	1526
Autovacuum settings	1526
PostgreSQL on Linux	1527
Transparent huge pages	1527
Host-based authentication	1527
Maintain Microsoft SQL Server Express	1528
Migrate Microsoft SQL Server Express to Enterprise	1528
Back up and restore your database	1529
Back up your database	1529
Restore the database only	1530
Restore both the Deep Security Manager and the database	1530
Export objects in XML or CSV format	1531
Import objects	1532
Navigate and customize Deep Security Manager	1532
Customize the dashboard	1532
Specify date and time range	1533
Specify computers and computer groups	1534

Filter by tags	1534
Select dashboard widgets	1535
Monitoring:	1535
System:	1536
Ransomware:	1537
Anti-Malware:	1537
Web Reputation:	1537
Firewall:	1537
Intrusion Prevention:	1538
Integrity Monitoring:	1539
Log Inspection:	1539
Application Control:	1540
Change the layout	1540
Save and manage dashboard layouts	1541
Group computers dynamically with smart folders	1542
Create a smart folder	1542
Edit a smart folder	1544
Clone a smart folder	1545
Focus your search using sub-folders	1545
Automatically create sub-folders	1545
Searchable Properties	1546
General	1546
AWS	1550
Azure	1551
GCP	1552
vCenter	1553
vCloud	1553
Active Directory	1554
Operators	1554

Customize advanced system settings	1556
Primary Tenant Access	1557
Load Balancers	1557
Multi-tenant Mode	1557
Deep Security Manager Plug-ins	1558
SOAP Web Service API	1558
Status Monitoring API	1558
Export	1558
Whois	1559
Licenses	1559
CPU Usage During Recommendation Scans	1559
NSX	1559
Logo	1559
Manager AWS Identity	1560
Application control	1560
Harden Deep Security	1565
About Deep Security hardening	1565
Protect Deep Security Manager with an agent	1566
Protect Deep Security Agent	1567
Import a Deep Security Manager certificate chain issued by a public CA	1569
Confirm the certificate chain is imported	1570
Delete the imported certificate chain	1570
Replace the Deep Security Manager TLS certificate	1570
Generate the private key and Java keystore	1571
Request a signed certificate (CSR)	1574
Import the signed certificate into the keystore	1575
Configure Deep Security Manager to use the keystore	1577
Regenerate self-signed certificates in Deep Security Manager (summary)	1578
Update the load balancer's certificate	1580

Encrypt communication between the Deep Security Manager and the database	1582
Encrypt communication between the manager and database	1583
Microsoft SQL Server database	1583
Oracle database	1584
PostgreSQL	1585
Running an agent on the database server	1585
Disable encryption between the manager and database	1585
Microsoft SQL Server	1586
Oracle Database	1586
PostgreSQL	1587
Upgrade from an old Deep Security Manager version	1587
Upgrade Deep Security Manager	1587
Change the Deep Security Manager database password	1588
Change your Microsoft SQL Server password	1588
Change your Oracle password	1589
Change your PostgreSQL password	1589
Configure HTTP security headers	1590
Customizable security headers	1590
HTTP Strict Transport Security (HSTS)	1591
Content Security Policy (CSP)	1591
HTTP Public Key Pinning (HPKP)	1592
Enable customizable security headers	1592
Reset your configuration	1593
HTTP Strict Transport Security	1593
Content Security Policy	1593
Public Key Pinning Policy	1593
Enforced security headers	1593
Cache-Control and Pragma	1594
X-XSS-Protection	1594

X-Frame-Options	1594
Unsupported security headers	1594
X-Content-Type-Options	1595
Upgrade the Deep Security cryptographic algorithm	1595
Upgrade the algorithm on Windows	1595
Upgrade the algorithm on Linux	1596
Upgrade the algorithm in a multi-node environment	1596
Upgrade the algorithm in a multi-tenant environment	1596
Enforce user password rules	1597
Specify password requirements	1597
Use another identity provider for sign-on	1598
Add a message to the Deep Security Manager Sign In page	1598
Present users with terms and conditions	1598
Other Security settings	1599
Set up multi-factor authentication	1599
Enable multi-factor authentication	1599
Disable multi-factor authentication	1602
Supported multi-factor authentication (MFA) applications	1602
Troubleshooting MFA	1603
What if my MFA is enabled but not working?	1603
What if my MFA device is lost or stops working?	1603
Manage trusted certificates	1603
Import trusted certificates	1603
View trusted certificates	1604
Remove trusted certificates	1605
SSL implementation and credential provisioning	1606
If I have disabled the connection to the Smart Protection Network, is any other information sent to Trend Micro?	1607
Upgrade Deep Security	1607

About upgrades	1607
How Deep Security Manager checks for software upgrades	1608
Best practices for upgrades	1609
How Deep Security validates update integrity	1610
Digital signatures	1610
Checksums	1611
Apply security updates	1611
Initiate security updates	1612
Check your security update status	1612
View details about pattern updates	1612
Revert, import, or view details about rule updates	1613
Configure security updates	1614
Enable automatic patches for rules	1614
Enable automatic Anti-Malware engine updates	1615
Enable security updates for older agents	1615
Change the alert threshold for late security updates	1616
Disable emails for New Pattern Update alerts	1616
Use a web server to distribute software updates	1617
Web server requirements	1617
Copy the folder structure	1617
Configure agents to use the new software repository	1619
Upgrade Deep Security Manager	1619
Before you begin	1620
Upgrade the manager	1620
Upgrade the manager if it's more than two releases old	1621
Upgrade the manager in a multi-node deployment	1621
Upgrade the manager in a multi-tenant environment	1622
What happens when you upgrade?	1622
Post-upgrade tasks	1623

Troubleshoot the manager upgrade (log files)	1623
Roll back an unsuccessful upgrade of the manager	1624
Upgrade Deep Security Relay	1624
Upgrade a relay starting from the manager	1625
Upgrade a relay by running the installer manually	1625
Upgrade Deep Security Agent	1625
Before you begin an upgrade	1626
Upgrade the agent starting from an alert	1627
Upgrade multiple agents at once	1628
Upgrade the agent from the Computers page	1628
Upgrade the agent on activation	1628
Upgrade the agent from a scheduled task	1629
Upgrade the agent manually	1629
Content of ds_adm.file	1631
Upgrade the agent embedded on the virtual appliance automatically	1632
Upgrade best practices for agents	1633
Upgrade Deep Security Virtual Appliance	1633
Check if new appliance software is available	1634
Determine which versions of the appliance SVM and embedded agent you're using	1634
Determine whether a new appliance SVM is available	1634
Determine whether a new agent is available	1635
Before upgrading the appliance	1635
Review system requirements and supported NSX versions	1635
Verify the vCenter and NSX account permissions	1635
Re-register NSX-T	1635
Import the new appliance ZIP into the manager	1636
Next steps	1637
Upgrade the appliance	1637

Upgrade an existing appliance SVM automatically	1637
Step 1: Upgrade the appliance SVM in the manager	1638
Troubleshooting the 'Appliance (SVM) Upgrade Failed' system event	1640
Step 2: Check that the upgrade succeeded	1641
Upgrade an existing appliance SVM manually	1641
Step 1: Review or restore identified files	1641
Step 2: Migrate guest VMs to another ESXi host	1641
Step 3: Upgrade your old appliance SVM	1642
Step 4: Check that maintenance mode was turned off	1647
Step 5: Check that the new appliance SVM is activated	1647
Step 6: Final step	1648
Upgrade the agent embedded on the appliance SVM	1648
Compatibility table: appliance, agent	1649
Upgrade the database	1649
The upgrade path	1650
Upgrade the database	1650
Error: The installer could not establish a secure connection to the database server ...	1651
Upgrade the NSX license for more Deep Security features	1651
Upgrade your NSX-T 3.x license	1652
Upgrade your NSX-V license	1652
Step 1: Upgrade your NSX license	1652
Step 2: Remove Deep Security from NSX completely	1656
Step 3: Redeploy the Deep Security Virtual Appliance	1656
Migrate an agentless solution from NSX-V to NSX-T	1656
Migration scenario 1	1657
Before migration	1657
Step 1: Prepare the NSX-T infrastructure for migration	1658
Step 2: Import a new appliance	1658
Step 3: Migrate	1658

Step 4: Verify the new deployment and its security features	1659
Step 5: Uninstall NSX-V from Deep Security Manager	1659
Migration scenario 2	1659
Before migration	1660
Step 1: Prepare the NSX-T network and vCenter infrastructure	1660
Step 2: Import a new appliance	1660
Step 3: Migrate	1660
Step 4: Verify the new deployment and its security features	1663
Step 5: Clean up NSX-V	1663
Update the security group for NSX-T	1663
Migrate security policies from NSX-V to NSX-T	1670
Check your current NSX-V configurations	1670
Re-create the Guest Introspection settings for NSX-T	1672
Re-create the Network Introspection settings for NSX-T	1673
Uninstall Deep Security	1675
Uninstall Deep Security	1675
Uninstall a Deep Security relay	1675
Uninstall a relay on Windows	1675
Uninstall a relay on Linux	1676
Uninstall Deep Security Agent	1676
Uninstall an agent on Windows	1676
Uninstall an agent on Linux	1677
Uninstall an agent on Solaris 10	1677
Uninstall an agent on Solaris 11	1678
Uninstall an agent on AIX	1678
Uninstall an agent on Red Hat OpenShift	1678
Uninstall Deep Security Notifier	1678
Uninstall Deep Security Manager	1678
Uninstall the manager on Windows	1678

Uninstall the manager on Linux	1679
Uninstall Deep Security from your NSX environment	1679
Uninstall Deep Security automatically	1680
Uninstall Deep Security from NSX-T 3.x manually	1681
Uninstall Deep Security from NSX-V manually	1688
Configure Deep Security Manager memory usage	1693
Configuring the installer's maximum memory usage	1693
Configuring Deep Security Manager's maximum memory usage	1693
Restart the Deep Security Manager	1694
Linux	1694
Windows	1694
Windows desktop	1694
Command prompt	1694
PowerShell	1695
Check your license information	1695
Check your current licenses	1695
See details about a license	1696
Add or upgrade a license	1696
Migrate to Workload Security	1697
Migrate from Deep Security to Workload Security	1697
Configure Workload Security account, users, roles, and authentication	1698
Create a role and an API key	1698
Prepare a link to Workload Security	1699
Migrate other Deep Security settings	1701
VMware connector and data center gateway	1701
Computer groups and smart folders	1702
Proxy configuration	1702
Event and alert logging	1702
Additional configuration	1703

Trend Micro Vision One (XDR) enrollment	1703
Configure network and communication settings	1703
Required ports, protocols, and URLs	1703
Proxy configuration	1703
Bandwidth utilization	1704
Relay configuration	1704
Migrate using the Deep Security and Workload Security APIs	1705
Migrate policies to Workload Security	1706
Prerequisites	1706
Limitations	1707
Migrate policies using the migration tool	1707
Other methods for migrating policies	1709
Migrate common objects to Workload Security	1709
Prerequisites	1710
Migrate common objects using the migration tool	1710
Migrate cloud accounts to Workload Security	1713
Prerequisites	1713
If you are migrating AWS accounts	1714
Limitations	1714
Migrate AWS accounts that were added using cross-account roles	1714
Create a new cross-account role	1714
Re-use existing cross-account roles	1714
Migrate other cloud accounts using the migration tool	1716
Migrate VMware vCloud accounts	1720
Migrate agents to Workload Security	1720
Prerequisites	1721
Migrate agents using the migration tool	1721
Check the move status	1723
Use Smart Folder to view move status	1727

Troubleshooting	1728
Restore an unmanaged agent manually	1728
Agent failed to stop	1728
Agent failed to start	1729
Other methods for migrating agents	1729
DevOps, automation, and APIs	1730
About DevOps, automation, and APIs	1730
Trend Micro Hybrid Cloud Security Command Line Interface (THUS)	1731
Command-line basics	1731
dsa_control	1731
dsa_control options	1732
Agent-initiated activation ("dsa_control -a")	1737
Agent-initiated heartbeat command ("dsa_control -m")	1737
Activate Deep Security Agent	1745
Windows	1745
Linux, AIX, and Solaris	1745
Force the agent to contact the manager	1745
Windows	1745
Linux, AIX, and Solaris	1746
Initiate a manual anti-malware scan	1746
Windows	1746
Linux, AIX, and Solaris	1746
Create a diagnostic package	1746
Reset the agent	1746
Windows	1746
Linux, AIX, and Solaris	1747
dsa_query	1747
dsa_query options	1747
Check CPU usage and RAM usage	1748

Windows	1748
Linux and Solaris	1748
AIX	1748
Check that ds_agent processes or services are running	1748
Windows	1748
Linux, AIX, and Solaris	1748
Restart an agent on Linux	1748
Restart an agent on Solaris	1749
Restart an agent on AIX	1749
dsa_scan	1749
dsa_scan options	1750
dsa_scan output	1750
Scan exit codes	1751
dsm_c	1753
dsm_c options	1753
Return codes	1764
Use the Deep Security API to automate tasks	1764
Legacy REST and SOAP APIs	1765
Enable the Status Monitoring API (optional)	1765
Create a Web Service user account	1766
Schedule Deep Security to perform tasks	1766
Create scheduled tasks	1766
Enable or disable a scheduled task	1769
Set up scheduled reports	1769
Automatically perform tasks when a computer is added or changed (event-based tasks)	1769
Create an event-based task	1769
Edit or stop an existing event-based task	1770
Events that you can monitor	1770

Conditions	1771
List of conditions and descriptions of each	1771
Java regex examples	1773
Actions	1774
Order of execution	1774
Temporarily disable an event-based task	1776
AWS Auto Scaling and Deep Security	1776
Pre-install the agent	1776
Install the agent with a deployment script	1777
Delete instances from Deep Security as a result of Auto Scaling	1779
Azure virtual machine scale sets and Deep Security	1779
Step 1: (Recommended) Add your Azure account to Deep Security Manager	1780
Step 2: Prepare a deployment script	1780
Step 3: Add the agent through a custom script extension to your VMSS instances	1781
Example 1: Create a new VMSS that includes the agent	1781
Example 2: Add the agent to an existing VMSS	1784
GCP auto scaling and Deep Security	1786
Pre-install the agent	1787
Install the agent with a deployment script	1788
Delete instances from Deep Security as a result of GCP MIGs	1789
Use deployment scripts to add and protect computers	1790
Generate a deployment script	1790
Troubleshooting and tips	1792
URL format for download of the agent	1794
Agent download URL format	1794
<dsm fqdn> parameter	1795
<filename> parameter	1795
<agent version> parameter	1796
Should I include the <agent version> explicitly in my scripts?	1796

<platform>, <arch>, and <filename> parameters	1797
Examples	1800
Exceptions for backwards compatibility	1800
Using agent version control to define which agent version is returned	1801
Examples	1801
Interactions between the <agent version> parameter and agent version control	1802
Automatically assign policies using cloud provider tags/labels	1802
Trust and compliance	1804
About compliance	1804
Agent package integrity check	1804
Troubleshoot	1804
Supported Deep Security Relay versions	1805
Meet PCI DSS requirements with Deep Security	1806
Common Criteria configuration	1806
Step 1: Install Deep Security	1807
Step 2: Enable FIPS mode	1808
Step 3: Harden Deep Security to prevent unauthorized access	1808
Step 4: Enforce a strong password policy	1809
Step 5: Disable the legacy APIs	1809
Step 6: Configure email notifications for alerts	1809
Next steps (operating in the certified configuration)	1809
GDPR	1810
FIPS 140 support	1811
Differences when operating Deep Security in FIPS mode	1812
Features available in FIPS mode	1812
How to check if FIPS mode is enabled	1812
System requirements for FIPS mode	1813
Deep Security Manager requirements	1813
Deep Security Agent requirements	1814

Deep Security Virtual Appliance requirements	1814
Enable FIPS mode for your Deep Security Manager	1814
Enable FIPS mode for a Deep Security Manager on Windows	1814
Enable FIPS mode for a Deep Security Manager on Linux	1815
Connect to external services when in FIPS mode	1815
Enable FIPS mode for the operating system of the computers you are protecting	1815
Enable FIPS mode for the Deep Security Agent on the computers you are protecting	1816
Enable FIPS mode for a Windows agent	1816
Enable FIPS mode for Linux agents	1817
Enable FIPS mode for the Deep Security Virtual Appliance	1817
Using FIPS mode with a PostgreSQL database	1817
Using FIPS mode with a Microsoft SQL Server database	1821
Disable FIPS mode	1822
Bypass vulnerability management scan traffic in Deep Security	1823
Create a new IP list from the vulnerability scan provider IP range or addresses	1823
Create firewall rules for incoming and outbound scan traffic	1823
Assign the new firewall rules to a policy to bypass vulnerability scans	1824
Use TLS 1.2 with Deep Security	1825
TLS 1.2 and Deep Security Agent Compatibility	1827
TLS 1.2 architectures	1827
Upgrade components to use TLS 1.2	1829
Verify and upgrade your Deep Security Manager	1830
Verify your Deep Security Manager database	1830
Verify your Deep Security Agents	1830
Verify your Deep Security Relays	1831
Verify your Deep Security Virtual Appliance	1831
Enforce TLS 1.2	1831
Where can TLS 1.2 be enforced?	1832
What happens when TLS 1.2 enforced?	1832

Is TLS 1.2 enforced by default?	1832
Under what circumstances is TLS 1.2 enforcement possible?	1832
Enforce TLS 1.2 on Deep Security Manager	1832
Enforce TLS 1.2 on the Deep Security Relay	1833
Enforce TLS 1.2 on just the manager's GUI port (4119)	1833
Test that TLS 1.2 is enforced	1834
Enable early TLS (1.0)	1835
Enable TLS 1.0 on Deep Security Manager and the Deep Security Relay	1836
Enable TLS 1.0 on the manager's GUI port (4119)	1836
Enable TLS 1.0 in deployment scripts	1837
Determine whether TLS 1.2 is enforced	1837
Guidelines for deploying agents, virtual appliances, and relays after TLS 1.2 is enforced	1838
Guidelines for deploying agents, virtual appliances, and relays when TLS 1.2 is enforced	1838
Guidelines for using deployment scripts when TLS 1.2 is enforced	1838
Enable TLS 1.2 strong cipher suites	1839
Check your environment	1839
Update Deep Security components	1840
Run a script to enable TLS 1.2 strong cipher suites	1840
Verify that the script worked	1841
Verify the manager using nmap	1841
Verify the relays using nmap	1842
Verify the agents using nmap	1843
Disable TLS 1.2 strong cipher suites	1843
Legal disclosures	1844
Privacy and personal data collection disclosure	1844
Deep Security Product Usage Data Collection	1845
Legal disclaimer	1845
Hot Fix	1845

Major release, Update, Patch or Service Pack	1846
Integrations	1846
Integrate with AWS Control Tower	1846
Overview	1846
Integrate with AWS Control Tower	1847
Upgrade the AWS Control Tower integration	1848
Remove AWS Control Tower integration	1848
Integrate with AWS Systems Manager Distributor	1848
Create an IAM policy	1848
Create a role and assign the policy	1848
Create parameters	1849
Integrate with AWS Systems Manager Distributor	1849
Protect your computers	1849
Integrate with SAP NetWeaver	1850
How it works	1850
Deep Security and SAP components	1851
Set up the integration between Deep Security Scanner and SAP NetWeaver	1852
Activate the Deep Security Scanner feature	1853
Install the agent	1854
Add the SAP Server to Deep Security Manager and activate the agent	1855
Assign a security profile	1858
Configure SAP to use the agent	1861
Configure the Trend Micro scanner group	1862
Configure the Trend Micro virus scan provider	1868
Configure the Trend Micro virus scan profile	1874
Test the virus scan interface	1884
Supported MIME types	1890
Integrate with Smart Protection Server	1894
Integrate with Trend Micro Vision One	1901

Integrate with Trend Micro Vision One (XDR)	1901
Register with Trend Micro Vision One (XDR)	1902
Forward security events to Trend Micro Vision One (XDR)	1902
Forward activity data to Trend Micro Vision One (XDR)	1903
Generate a deployment script	1903
Download the agent installer	1904
Integrate with Trend Vision One Service Gateway	1904
Supported Service Gateway version	1904
Set up a scheduled report	1904
Deploy Service Gateway	1905
FAQs	1905
Why does my Windows machine lose network connectivity when I turn on protection? ..	1905
How do I get news about Deep Security?	1906
How does agent protection work for Solaris zones?	1906
Intrusion Prevention (IPS), Firewall, and Web Reputation	1906
Non-global zones use a shared-IP network interface	1907
Non-global zones use an exclusive-IP network interface	1907
Anti-Malware, Integrity Monitoring, and Log Inspection	1908
How do I protect AWS GovCloud (US) instances?	1908
Protecting AWS GovCloud (US) instances using a manager in a commercial AWS instance	1908
How do I protect Azure Government instances?	1909
Protecting Azure Government instances using a manager in global Azure	1911
How does Deep Security Agent use the Amazon Instance Metadata Service?	1911
How can I minimize heartbeat alerts for offline environments in an AWS Elastic Beanstalk environment?	1912
Why can't I add my Azure server using the Azure cloud connector?	1913
Why can't I view all of the VMs in an Azure subscription in Deep Security?	1914
Deep Security coverage of Log4j vulnerability	1914
Apply virtual patching for the Log4j vulnerability	1915

Identify potentially affected hosts	1917
Use a custom Log Inspection rule to investigate activity	1917
More resources from Trend Micro about this vulnerability	1917
Troubleshooting	1918
"Offline" agent	1918
Causes	1918
Verify that the agent is running	1919
Verify DNS	1920
Allow outbound ports (agent-initiated heartbeat)	1920
Allow inbound ports (manager-initiated heartbeat)	1921
Allow ICMP on Amazon AWS EC2 instances	1922
Fix the upgrade issue on Solaris 11	1922
High CPU usage	1923
Diagnose problems with agent deployment (Windows)	1924
"Anti-Malware Driver Offline" status with VMware	1924
Anti-Malware Windows platform update failed	1924
An incompatible Anti-Malware component from another Trend Micro product	1925
An incompatible Anti-Malware component from a third-party product	1925
The certificate is not signed by Trend Micro	1925
The signed certificate is not trusted	1926
The signed certificate is not authorized with appropriated purpose	1926
Other/Unknown Error	1926
Performance issues on an agentless virtual machine	1927
Cause: Limited resources	1927
Cause: Anti-malware	1927
Cause: Network traffic	1927
Cause: Policy	1927
Cause: High CPU	1928
Cause: Security Update	1928

Security update connectivity	1929
SQL Server domain authentication problems	1929
Step 1: Verify the host name and domain	1930
Step 2: Verify the servicePrincipalName (SPN)	1931
Step 2a: Identify the account (SID) running the SQL Server service	1932
Step 2b: Find the account in Active Directory	1934
Step 2c: Identify which FQDN to use in the SPN	1935
Step 2d: Identify whether you're using a default instance or named instance	1935
Case 1: Set the SPN under a local virtual account	1936
Case 2: Set the SPN under a domain account	1938
Case 3: Set the SPN under a Managed Service account	1940
Case 4: Set the SPN for a failover cluster	1942
SPN references	1944
SPN debugging tips	1944
Step 3: Verify the krb5.conf file (Linux only)	1945
Step 4: Verify the system clock	1947
Step 5: Verify the firewall	1947
Step 6: Verify the dsm.properties file	1948
Prevent MTU-related agent communication issues across Amazon Virtual Private Clouds (VPC)	1949
Create a diagnostic package and logs	1951
Deep Security Manager diagnostics	1951
Create a diagnostic package for Deep Security Manager	1951
Enable debug logs for Deep Security Manager	1951
Deep Security Agent diagnostics	1952
Create an agent diagnostic package via Deep Security Manager	1953
Create an agent diagnostic package via CLI on a protected computer	1954
Collect debug logs with DebugView	1954
Increase verbose diagnostic package process memory	1955

Removal of older software versions	1956
Troubleshoot SELinux alerts	1956
SELinux blocks the Deep Security Agent service	1957
Berkeley Packet Filter (BPF) operations blocked	1958
Troubleshoot Azure Code Signing	1959
Network Engine Status (Windows OS)	1961
Network Engine Status warnings	1961
Verify the driver status	1961
Disable Network Engine Status warnings	1962
PDFs	1962
Deep Security Administration Guide	1962
Deep Security Best Practice Guide	1962

About Deep Security

Deep Security 20 release strategy and life cycle policy

Deep Security 20 is a long-term support (LTS) release. Its release management and life cycle changes are designed to be easier for our customers and partners:

- Deep Security 20 updates include both new features and fixes to deliver new features faster.
- Feature Releases (FR) are no longer released to reduce the number of software upgrades and simplify the support policy.

The manager supports older agent versions, but you should still upgrade agents when possible. New agent releases provide more security features and protection, higher quality, performance improvements, and updates to stay in sync with OS releases. Regular software upgrades also ensure that, if an agent fix is required, you can simply update once – not install multiple updates along a supported upgrade path. Each agent has an end-of-life date. For details, see [Deep Security Agent LTS life cycle date](#) and [Deep Security Agent FR life cycle dates](#).

Supported upgrade paths

Deep Security supports upgrades from the last 2 major releases for all [Deep Security components](#), as long as the release that you're upgrading from is **still within its support period**. See the support periods [for LTS releases](#) or [for FR releases](#) to make sure the version you're upgrading from is supported.

You can upgrade to Deep Security 20 from these versions until they reach their end-of-support dates:

- Deep Security 11 (LTS)
- Deep Security 12 (LTS)
- Deep Security 12 (FR)

You can also update any currently supported Deep Security 20 release to a more recent update release of it. Rolling back to a previous release is not supported.

Deep Security 20 update schedule

Like previous LTS releases, Deep Security 20 updates will be released monthly. If needed (such as due to critical fixes or vulnerabilities), more frequent releases will be provided.

Each [component](#) can be released independently. Agents for different [platforms](#) (Windows, Linux, Unix) can also be released separately. An update may include one or more components and platforms. In general, the global release process is completed within one week after the release date, at which time the update becomes available in the Download Center.

If you require a fix for a currently supported software release, then Trend Micro will release an update that can be directly applied during the support period. For example, if you had Deep Security 20 Update 2 and have an issue, then when the latest update is released (for example Deep Security 20 Update 10), you could update directly from Update 2 to Update 10 so that you can quickly resolve the issue.

LTS release support duration and upgrade best practices

A key best practice for software updates is to have a well-defined, regularly scheduled, and, ideally, automated process to update all components regularly.

The following table summarizes when updates are released, the support duration of that component, and considerations when designing your upgrade strategy.

Note: Because there are multiple years of Deep Security 20 LTS updates, the support periods for Deep Security 20 are based on the year the update was released. For example, all Deep Security 20 LTS updates released in 2020 have standard support until December 31, 2023 and extended support until December 31, 2024. All Deep Security 20 LTS updates released in 2021 have standard support until December 31, 2024 and extended support until December 31, 2025.

Component	When are updates released?	Support	Upgrade considerations
Deep Security Manager	LTS updates are released monthly	Standard support until 3 years after the	Plan to upgrade regularly so that you are always using a supported release, and can upgrade to the latest software with a single upgrade.

Component	When are updates released?	Support	Upgrade considerations
		year of release. Extended support until 4 years after the year of release.	
Deep Security Agent	LTS updates are released monthly	Standard support until 3 years after the year of release. Extended support until 4 years after the year of release.	LTS agents support upgrades from the last 2 major releases (for example, Deep Security Agent 11.0 to Deep Security Agent 20 LTS) that are still within their support period. Plan to upgrade regularly so that you are always using a supported release and are able to upgrade to the latest software with a single upgrade.
Deep Security Agent (platforms where an older release of the agent is the 'latest' agent for that platform)	LTS updates are released monthly	Platform-specific	If platform support is only provided by an older release of Deep Security Agent (for example, Windows 2000 uses a 9.6 agent and Red Hat Enterprise Linux 5 uses a 10.0 agent), use the latest agent for that platform and upgrade as updates are released. For details on which agent versions are supported for each platform, see "Agent platform compatibility" on page 336 .
Deep Security Relay	LTS updates are released monthly	Same as agent	Deep Security Relay is simply a Deep Security Agent that has relay functionality enabled. The upgrade recommendations and support policies for agents also apply to relays.
Deep	Released	Standard	Appliance SVM: Plan to upgrade yearly.

Component	When are updates released?	Support	Upgrade considerations
Security Virtual Appliance	with each LTS release of Deep Security	support until 3 years after GA. Extended support until 4 years after GA.	Embedded agent: Plan to upgrade: <ul style="list-style-type: none"> at least yearly, or whenever a new compatible agent is available, or regularly so that you are always using a supported, release and are able to upgrade to the latest software with a single upgrade

Support services

These items are supported during the life cycle of Deep Security 20. Extended support is provided to all customers at no additional cost.

Support item	LTS - standard support	LTS - extended support	LTS - limited support	Delivery mechanism
New features ¹	✓	✓		LTS update
Small enhancements (no change to core functionality) ¹	✓	✓		LTS update
Linux kernel updates	✓	On request		Linux Kernel Support Package (LKP)
General bug fixes ¹	✓	✓		LTS update
Critical bug fixes (system crash or hang, or loss of major functionality)	✓	✓		LTS update or hotfix
Critical and high vulnerability fixes	✓	✓		LTS update or hotfix
Medium and low vulnerability fixes	✓	✓		LTS update

Support item	LTS - standard support	LTS - extended support	LTS - limited support	Delivery mechanism
Anti-Malware pattern updates	✓	✓	✓	iAU (Active Update)
Intrusion Prevention, Integrity Monitoring, and Log Inspection rule updates	✓	✓	✓	iAU (Active Update)
Support for agents and Deep Security Manager on new versions of supported operating systems	✓	✓		LTS update

Footnotes:

1

Agent platforms that are not supported are not included. See ["Agent platform compatibility" on page 336](#).

Agent platform support policy

We recognize that sometimes you must commit to an OS for many years. The agent platform support policy is designed to provide predictable support for the platform's lifespan.

- Many platforms are supported. See ["Agent platform compatibility" on page 336](#).
- Platforms will be supported until at least the OS vendor's end-of-extended-support date. Trend Micro might extend support beyond this date. However once an OS vendor no longer supports its platform, there is a risk that some technical issues might not be fixable without the support of the OS vendor. If this happens, Trend Micro will notify you immediately, but it could result in loss of functionality.
- Trend Micro will notify you in advance if we will end support for a platform.
- After General Availability (GA) of software, we will not shorten its support life cycle, except possibly if the OS vendor stops supporting the platform.
- Consider [how long the agent version will be supported](#). For example, agent 11.0, 12.0, and

so on (LTS releases) have 3 years of standard support and 4 years of extended support. If you will use an OS for longer than that, then you must plan to regularly upgrade the agent so that you are always using an agent version that is currently supported.

- A new version of the agent is usually released for all supported platforms. However, to support older platforms, sometimes a deployment must include a previous release of the agent, and therefore its end-of-support dates are adjusted accordingly.

For example, the newest agent for Windows 2000 is Deep Security Agent 9.6, so Deep Security Manager 11.0 supports it, even though the rest of the deployment uses Deep Security Agent 11.0. Therefore in this context, the older agent uses the EOL dates for Deep Security 11.0, not Deep Security 9.6.

Tip: To get the latest performance and security updates from your OS vendor, Trend Micro strongly encourages you to upgrade to the latest OS version for which an agent is available.

Deep Security life cycle dates

Deep Security LTS life cycle dates



[Subscribe via RSS](#)

Please refer to Trend Micro's latest [End-of-Life Policy](#) for more information on milestone definitions and standard timelines.

Deep Security Manager supports the use of older agent versions (see "[Agent platform compatibility](#)" on page 336), but we do encourage customers to upgrade agents regularly. New agent releases provide additional security features and protection, better quality, performance improvements, and updates to stay in sync with releases from each platform vendor.

You can find more information in the "[Deep Security 20 release strategy and life cycle policy](#)" on page 104. For feature releases, see "[Deep Security FR life cycle dates](#)" on page 116.

Note: Products for the Japan region are handled under a [region-specific policy](#).

Deep Security LTS release life cycle dates

The following table defines the dates for each Deep Security long-term support (LTS) release. These dates define the life cycle for all components (manager, agents, relays, security updates) within the release, with the exception of any items listed in ["Support extensions" on the next page](#).

Version	Component	Platform	GA date	End of standard support	End of extended support (EOL)
Deep Security 9.0	All	All	11-Feb-2013	31-Dec-2017	Extended support was introduced in Deep Security 10.0. See the Trend Micro End-of-Life Policy for terms and definitions. These versions have reached EOL.
Deep Security 9.5	All	All	13-Aug-2014	17-Aug-2018	
Deep Security 9.6	All	All	12-Aug-2015	12-Aug-2019	
Deep Security 10.0	All	All	09-Mar-2017	09-Mar-2020	09-Mar-2021
Deep Security 11.0	All	All	22-May-2018	23-May-2021	22-May-2022
Deep Security 12.0	All	All	20-Jun-2019	20-Jun-2022	20-Jun-2023
Deep Security 20 (GA and all updates released in 2020)	All	All	2020	31-Dec-2023	31-Dec-2024
Deep Security 20 (all updates)	All	All	2021	31-Dec-2024	31-Dec-2025

Version	Component	Platform	GA date	End of standard support	End of extended support (EOL)
released in 2021)					
Deep Security 20 (all updates released in 2022)	All	All	2022	31-Dec-2025	31-Dec-2026
Deep Security 20 (all 20.0.0 updates released in 2023)	All	All	2023	31-Dec-2026	31-Dec-2027
Deep Security 20 (all 20.0.1 updates released in 2024)	All	All	2024	31-Dec-2027	31-Dec-2028

Deep Security Virtual Appliance release life cycle dates

The Deep Security Virtual Appliance will [reach end of extended support \(EOL\)](#) on 31-Dec-2027, or VMware's end of support date for NSX-4.X, whichever comes first.

Support extensions

The following table defines specific extensions to the life cycle dates listed above.

Platform	Component	Version	Updated end of life (EOL)	More information
Windows 2000	Agent	Deep Security	31-Dec-	IMPORTANT BULLETIN: Trend Micro

Platform	Component	Version	Updated end of life (EOL)	More information
		9.6	2025 1	<p>Server and Endpoint Protection Agent Minimum Windows Version Requirements for Updated Binaries After Mid-February 2023</p> <p>Deep Security Windows 2000 Platform Support Update</p> <p>Updated guidance on how to use Trend Micro Deep Security to protect Windows 2003, Windows XP, and Windows 2000 based systems</p> <p>Support will continue, as per "Agent platform support policy" on page 108</p>
Windows 2003	Agent	Deep Security 10.0	31-Dec-2025 1	<p>IMPORTANT BULLETIN: Trend Micro Server and Endpoint Protection Agent Minimum Windows Version Requirements for Updated Binaries After Mid-February 2023</p> <p>Deep Security Windows 2003 Platform Support Update.</p> <p>Updated guidance on how to use Trend Micro Deep Security to protect Windows 2003, Windows XP, and Windows 2000 based systems</p> <p>Support will continue, as per "Agent platform support policy" on page 108</p>
Windows XP	Agent	Deep Security 10.0 Update	30-Jul-2024	<p>IMPORTANT BULLETIN: Trend Micro Server and Endpoint Protection Agent Minimum Windows Version Requirements</p>

Platform	Component	Version	Updated end of life (EOL)	More information
		25 or earlier		<p>for Updated Binaries After Mid-February 2023</p> <p>Updated guidance on how to use Trend Micro Deep Security to protect Windows 2003, Windows XP, and Windows 2000 based systems</p> <p>Support will continue, as per "Agent platform support policy" on page 108</p>
Windows 7	Agent	Deep Security 20.0.0	31-Dec-2026	Starting in 2024, limited support will be provided, as per Platform support updates for Deep Security Agent (DSA) version revision in January 2024 Update Release
Windows 2008	Agent	Deep Security 20.0.0	31-Dec-2026	Starting in 2024, limited support will be provided and conditional fixes will be available, as per Platform support updates for Deep Security Agent (DSA) version revision in January 2024 Update Release
Windows 8.1	Agent	Deep Security 20.0.0	31-Dec-2026	Starting in 2024, limited support will be provided, as per Platform support updates for Deep Security Agent (DSA) version revision in January 2024 Update Release
CloudLinux 5 (32- and 64-bit)	Agent	Deep Security 9.6	31-Dec-2025 ¹	Support will continue, as per "Agent platform support policy" on page 108
Cloud Linux 6 (32-bit)	Agent	Deep Security 10.0	31-Dec-2025 ¹	Support will continue, as per "Agent platform support policy" on page 108

Platform	Component	Version	Updated end of life (EOL)	More information
Cloud Linux 6 (64-bit)	Agent	Deep Security 11.0	31-Dec-2025 1	Support will continue, as per "Agent platform support policy" on page 108
Debian 6	Agent	Deep Security 9.6	31-Dec-2025 1	Support will continue, as per "Agent platform support policy" on page 108
Debian 7	Agent	Deep Security 12.0	31-Dec-2025 1	Support will continue, as per "Agent platform support policy" on page 108
Debian 8	Agent	Deep Security 20.0.0	31-Dec-2026	Starting in 2024, limited support will be provided, as per Platform support updates for Deep Security Agent (DSA) version revision in January 2024 Update Release
Oracle Linux 5	Agent	Deep Security 10.0	31-Dec-2025 1	Support will continue, as per "Agent platform support policy" on page 108
Red Hat Enterprise Linux 5	Agent	Deep Security 10.0	31-Dec-2025 1	Support will continue, as per "Agent platform support policy" on page 108
SUSE Linux Enterprise Server 11	Agent	Deep Security 12.0	31-Dec-2025 1	Support will continue, as per "Agent platform support policy" on page 108
Ubuntu 10, 12	Agent	Deep Security 9.6	31-Dec-2025 1	Support will continue, as per "Agent platform support policy" on page 108
Ubuntu 14	Agent	Deep Security 10.0	31-Dec-2025 1	Support will continue, as per "Agent platform support policy" on page 108
CentOS 5	Agent	Deep	31-	Support will continue, as per "Agent

Platform	Component	Version	Updated end of life (EOL)	More information
		Security 10.0	Dec-2025 ¹	"platform support policy" on page 108
AIX 6.1	Agent	Deep Security 20.0.0	31-Dec-2026	Starting in 2024, limited support will be provided, as per Platform support updates for Deep Security Agent (DSA) version revision in January 2024 Update Release

Footnotes:

1

This platform is currently supported using an older version of Deep Security Agent. Support for this platform will not be extended past this date. See also "[Agent platform support policy](#)" on [page 108](#). For legacy OS support in the Japan region, see the [region-specific policy](#).

Archive of past support extensions

Platform	Component	Version	Updated end of life (EOL)	More information
All	Appliance	Deep Security 9.5	12-Aug-2019	The Deep Security Virtual Appliance 9.5 embedded agent must be upgraded to version 9.6 to adopt this EOL date. If you do not do this, then an EOL date of August 17, 2018 applies. Upgrading the embedded agent beyond version 9.6 will not extend the EOL date.
Windows 2000	Agent	Deep Security 8.0	12-Aug-2019	Deep Security Windows 2000 Platform Support Update Updated the guidance on how to use Trend Micro Deep Security to protect Windows 2003, Windows XP, and Windows 2000 based systems

Platform	Component	Version	Updated end of life (EOL)	More information
Solaris	Agent	Deep Security 9.0	31-Dec-2019	Deep Security Solaris Platform Support Update
HP-UX	Agent	Deep Security 9.0	09-Mar-2020	Only supported for use with Deep Security Manager 10.0. Support for HP-UX platform with Deep Security
AIX	Agent	Deep Security 9.0	31-Dec-2020	Deep Security AIX Platform Support Update
Windows XP Embedded	Agent	Deep Security 9.6	9-Mar-2021	
SUSE Linux Enterprise Server 10 SP3, SP4 (32- and 64-bit)	Agent	Deep Security 9.6	23-May-2021	Deep Security SuSE Enterprise Linux 10 Platform Support Update

Deep Security FR life cycle dates



[Subscribe via RSS](#)

Please refer to Trend Micro's latest [End-of-Life Policy](#) for more information on milestone definitions and standard timelines.

Note: To reduce the number of software releases and simplify understanding of the support policy, we are no longer releasing Feature Releases (FR) after the release of Deep Security 20. See "[Deep Security 20 release strategy and life cycle policy](#)" on page 104.

Note: Products for the Japan region are handled under a [region-specific policy](#).

Deep Security FR release life cycle dates

The following table defines the dates for each Deep Security feature release (FR). These dates define the life cycle for all components (manager, agents, relays, security updates) within the release, with the exception of any items listed in the ["Support extensions" on the next page](#) section, below.

Version	Component	Platform	Build number	GA date	End of support
Deep Security 10.1	All	All	10.1.*	11-Jul-2017	22-Nov-2018
Deep Security 10.2	All	All	10.2.*	24-Nov-2017	22-Nov-2018
Deep Security 10.3	All	All	10.3.*	18-Jan-2018	22-Nov-2018
Deep Security 11.1	All	All	11.1.*	16-Jul-2018	20-Dec-2019
Deep Security 11.2	All	All	11.2.*	10-Oct-2018	20-Dec-2019
Deep Security 11.3	All	All	11.3.*	07-Jan-2019	20-Dec-2019
Deep Security 12 FR 2019-10-23	Manager	All	12.5.349	23-Oct-2019	23-Apr-2021
Deep Security 12 FR 2019-12-12	Manager	All	12.5.494	12-Dec-2019	12-Jun-2021
Deep Security 12 FR 2020-01-27	Manager	All	12.5.613	27-Jan-2020	27-Jul-2021
Deep Security 12 FR 2020-03-09	Agent	Windows	12.5.0-713	09-Mar-2020	09-Sep-2021
Deep Security 12 FR 2020-03-09	Manager	All	12.5.732	09-Mar-2020	09-Sep-2021
Deep Security 12 FR 2020-	Agent	Linux	12.5.0-	02-Apr-	02-Oct-

Version	Component	Platform	Build number	GA date	End of support
04-02			814	2020	2021
Deep Security 12 FR 2020-04-16	Agent	Windows	12.5.0-834	16-Apr-2020	16-Oct-2021
Deep Security 12 FR 2020-04-29	Manager	All	12.5.855	29-Apr-2020	29-Oct-2021
Deep Security 12 FR 2020-05-19	Agent	Linux	12.5.0-936	19-May-2020	19-Nov-2021
Deep Security 12 FR 2020-06-17	Manager	All	12.5.985	17-Jun-2020	17-Dec-2021
Deep Security 12 FR 2020-06-17	Agent	All	12.5.0-1033	17-Jun-2020	17-Dec-2021

Support extensions

The following table defines specific extensions to the life cycle dates listed above.

Version	Component	Platform	Updated end of life	More information
Deep Security 10.1, 10.2, 10.3	Deep Security Agent Linux Kernel Updates	Linux	22-Nov-2019	Extending Linux kernel updates for Deep Security 10.x feature release agents
Deep Security 11.1, 11.2, 11.3	Deep Security Agent Linux Kernel Updates	Linux	31-Dec-2020	Extending Linux kernel updates for Deep Security 11.1, 11.2, 11.3 Feature Release Agents

About the Deep Security components

Trend Micro Deep Security provides advanced server security for physical, virtual, and cloud servers. It protects enterprise applications and data from breaches and business disruptions without requiring emergency patching. This comprehensive, centrally managed platform helps you simplify security operations while enabling regulatory compliance and accelerating the ROI of virtualization and cloud projects.

For information on the protection modules that are available for Deep Security, see "[About the Deep Security protection modules](#)" below.

Deep Security consists of the following set of components that work together to provide protection:

- **Deep Security Manager**, the centralized web-based management console that administrators use to configure security policy and deploy protection to the enforcement components: the Deep Security Virtual Appliance and the Deep Security Agent.
- **Deep Security Virtual Appliance** is a security virtual machine built for VMware vSphere environments that agentlessly provides anti-malware and integrity monitoring protection modules for virtual machines in a vShield environment. In an NSX environment, the anti-malware, integrity monitoring, firewall, intrusion prevention, and web reputation modules are available agentlessly.
- **Deep Security Agent** is a security agent deployed directly on a computer which provides application control, anti-malware, web reputation service, firewall, intrusion prevention, integrity monitoring, and log inspection protection to computers on which it is installed.
- The Deep Security Agent contains a **Relay** module. A relay-enabled agent distributes software and security updates throughout your network of Deep Security components.
- **Deep Security Notifier** is a Windows taskbar [application](#) that communicates information on the local computer about security status and events, and, in the case of relay-enabled agents, also provides information about the security updates being distributed from the local machine.

About the Deep Security protection modules

Trend Micro Deep Security has tightly integrated modules that easily expand your security capabilities:

- ["Intrusion Prevention " below](#)
- ["Anti-Malware " below](#)
- ["Firewall " below](#)
- ["Web Reputation " on the next page](#)
- ["Integrity Monitoring " on the next page](#)
- ["Log Inspection " on the next page](#)
- ["Application Control" on the next page](#)
- ["Device Control" on page 122](#)

Intrusion Prevention

The Intrusion Prevention module inspects incoming and outgoing traffic to detect and block suspicious activity. This prevents exploitation of known and zero-day vulnerabilities. Deep Security supports "virtual patching": you can use Intrusion Prevention rules to shield from known vulnerabilities until they can be patched, which is required by many compliance regulations. You can configure Deep Security to automatically receive new rules that shield newly discovered vulnerabilities within hours of their discovery.

The Intrusion Prevention module also protects your web applications and the data that they process from SQL injection attacks, cross-site scripting attacks, and other web application vulnerabilities until code fixes can be completed.

For more information, see ["Set up Intrusion Prevention" on page 882](#).

Anti-Malware

The Anti-Malware module protects your Windows and Linux workloads against malicious software, such as malware, spyware, and Trojans. Powered by the Trend Micro™ Smart Protection Network™, the Anti-Malware module helps you instantly identify and remove malware and block domains known to be command and control servers.

For more information, see ["Enable and configure anti-malware" on page 805](#).

Firewall

The Firewall module is for controlling incoming and outgoing traffic and it also maintains firewall event logs for audits.

For more information, see ["Set up the Deep Security firewall" on page 927](#).

Web Reputation

The majority of today's attacks start with a visit to a URL that's carrying a malicious payload. The Web Reputation module provides content filtering by blocking access to malicious domains and known communication and control (C&C) servers used by criminals. The Web Reputation module taps into the Trend Micro Smart Protection Network, which identifies new threats quickly and accurately.

For more information, see ["Configure Web Reputation" on page 871](#).

Integrity Monitoring

The Integrity Monitoring module provides the ability to track both authorized and unauthorized changes made to an instance and enables you to receive alerts about unplanned or malicious changes. The ability to detect unauthorized changes is a critical component in your cloud security strategy because it provides visibility into changes that could indicate the compromise of an instance.

For more information, see ["Set up Integrity Monitoring" on page 977](#).

Log Inspection

The Log Inspection module captures and analyzes system logs to provide audit evidence for PCI DSS or internal requirements that your organization may have. It helps you to identify important security events that may be buried in multiple log entries. You can configure Log Inspection to forward suspicious events to an SIEM system or centralized logging server for correlation, reporting, and archiving.

For more information, see ["Set up Log Inspection" on page 1039](#).

Application Control

The Application Control module monitors changes - "drift" or "delta" - compared to the computer's original software. Once application control is enabled, all software changes are logged and events are created when it detects new or changed software on the file system. When Deep Security Agent detects changes, you can allow or block the software, and optionally lock down the computer.

For more information, see ["Verify that Application Control is enabled" on page 1082](#).

Device Control

The Device Control module regulates access to external storage devices connected to computers. Device Control helps prevent data loss and leakage and, combined with file scanning, helps guard against security risks.

For more information, see ["Configure Device Control" on page 974](#).

About this release

What's new?

LTS releases of Deep Security are made available on an annual basis and include new functionality, enhancements for existing functionality, and bug fixes. LTS releases include long-term support, as described in ["LTS release support duration and upgrade best practices" on page 105](#). Once an LTS release is made generally available, updates to LTS releases are restricted to only fixes and small enhancements.

With Deep Security 20, each [component](#) (manager, agent, appliance) can be released independently. Agents for different [platforms](#) (Windows, Linux, Unix) can also be released separately. An update may include one or more components and platforms.

Read:

- ["What's new in Deep Security Manager?" below](#)
- ["What's new in Deep Security Agent?" on page 177](#)
- ["What's new in Deep Security Virtual Appliance?" on page 326](#)

What's new in Deep Security Manager?

Deep Security Manager - 20.0.904 (20 LTS Update 2024-04-17)

Release date: April 17, 2024

Build number: 20.0.904

New Features

Cross-account AWS role registration: Seed region and Security Token Service (STS) endpoint selection can now be done using the AWS connector wizard and AWS account properties page in Deep Security Manager.

Enhancements

- Deep Security Manager now supports Oracle Database 23c. DSM-366
- Changed the Migration API default timeout for Cloud One Endpoint & Workload Security to 60 seconds. The previous default was 10 seconds, which sometimes led to timeout before agents were transferred from Deep Security Manager. The timeout can be set between 10 and 1200 seconds (20 minutes) using the `settings.configuration.defaultWorkloadSecurityMigrationApiTimeout`. PCT-21902/PCT-22361/PCT-22860/PCT-22249/DSM-579
- Updated third-party licenses for Deep Security Manager. DSM-564
- Improved Azure connector performance for some system configurations. DSM-472

Resolved issues

- Changes to the Deep Security Virtual Appliance OVF file's IP address (**Computer > Properties > NSX Configuration > General**) sometimes failed to be applied. PCT-20529/PCT-23331/DSM-545
- The public IP and network security group were not being displayed in the virtual machine summary for some Azure VM configurations. DSM-459
- Database connection issues sometimes caused Deep Security Manager to delete in-use Deep Security Agent installers. SEG-188888/PCT-7221/PCT-15200/DSM-348
- Deep Security Manager's console displayed Windows 10 Enterprise multi-session as "Windows Server 2019" when it should have displayed the platform as "Windows 10." SEG-131712/DS-69474/DSM-326

Deep Security Manager - 20.0.893 (20 LTS Update 2024-03-20)

Release date: March 20, 2024

Build number: 20.0.893

Enhancements

- Anti-Malware Manual Scan can now be configured from a policy on Deep Security Manager for Linux platforms. DSM-433

Resolved issues

- Event Forwarding conditions `StringLike` and `StringNotLike` did not work for JSON formatted on multiple lines for a `Description`. SF07518120/PCT-12618/DSM-448
- Deep Security Manager sometimes displayed a Trend Micro Adversary Tactics and Techniques Detection pattern version (**Administration > Updates > Security > Patterns**) before it was available from the Trend Micro Update Server. DSM-439

Deep Security Manager - 20.0.883 (20 LTS Update 2024-02-21)

Release date: February 21, 2024

Build number: 20.0.883

New Features

- Deep Security Manager now supports dynamic updates of the XDR Device ID of the Trend Micro Endpoint Basecamp. DSM-250

Enhancements

- The Web Reputation Service backend query now uses port 443 by default for new installations and new tenants. PCT-10486/DSM-445
- In the Anti-Malware configuration, the default values for Predictive Machine Learning and Windows Antimalware Scan Interface (AMSI) settings are now marked as recommended. PCT-3844/DSM-301

Resolved issues

- Upgrading to Deep Security Agent 20.0.0-7943, 20.0.0-8137, 20.0.0-8268, or 20.0.0-8438 sometimes failed when Firewall, Web Reputation Service, or Intrusion Prevention System were enabled for Deep Security Manager. DSM-473

Deep Security Manager - 20.0.879 (20 LTS Update 2024-01-17)

Release date: January 17, 2024

Build number: 20.0.879

New Features

- Deep Security Manager now allows changing the IP address or fully qualified domain name (FQDN) for the NSX Manager. DSM-83/DSM-405

Enhancements

- The Tomcat version was updated in Deep Security Manager. DSM-431/DSM-160
- A number of URLs on a verge of becoming invalid were updated on the Deep Security Manager Support website. DSM-352
- Deep Security Manager copyright information was updated to year 2024. DSM-133
- A dedicated banner is now displayed within Deep Security Manager to notify the users of Deep Security Virtual Appliance about the Deep Security Virtual Appliance EOL status. DS-76857/DSM-131
- Security updates for VRTS-10045, VRTS-10068, VRTS-10070. DSM-133
- Deep Security Manager copyright information was updated to year 2024. DSM-133
- Deep Security Manager can now force the removal of the service reference ID when the VMware vCenter connector is removed. This service reference ID is automatically created by VMware NSX-T to bind the Trend Micro service with the security profile. SEG-160298/DSM-49
- The out-of-date computer status is now represented by three separate statuses: **Out of Date (Anti-Malware Configuration Off)**, **Out of Date (Anti-Malware Offline)**, and **Out of Date (Agent Offline)**. This directly affects the functionality of the security pattern status widget, ensuring that the **Out-of-Date Advanced Search** results do not include Deep Security Agents with the statuses Agent Offline, Anti-Malware Configuration Off, and Anti-Malware Offline. DSM-135

Resolved issues

- Azure Connector experienced synchronization issue for Azure Virtual Machine Scale Sets with Flexible orchestration mode. DSM-436

- Apex Central did not have the information and therefore could not forward it to syslog or display in its log view due to the MCP content not being updated to include the FileSHA1 of an infected file. SEG-192045/PCT-6042/DSM-435
- The value of the behaviorMonitoringEnabled property in the Antimalware Configuration API was missing, resulting in a disconnect between the UI and API. PCT-5360/DSM-411

Known issues

- Upgrading to Deep Security Agent 20.0.0-7943, 20.0.0-8137, 20.0.0-8268, or 20.0.0-8438 sometimes fails when Firewall, Web Reputation Service, or Intrusion Prevention System are enabled for Deep Security Manager. DSM-473

Security updates

Security updates are included in this release. For more information about Trend Micro protection against vulnerabilities, see [Vulnerability Response](#). Note that in line with responsible disclosure practices, CVE details can only be made available for select security updates once patches have been made available for all impacted releases. DSM-402

Highest CVSS: 7.5

Highest severity: High

Deep Security Manager - 20.0.864 (20 LTS Update 2023-12-12)

Release date: December 12, 2023

Build number: 20.0.864

Enhancements

- Updated the Deep Security Manager UI to reflect Microsoft's product name change: Azure Active Directory is now Microsoft Entra ID. DSM-214
- Deep Security Manager reports (**Events & Reports > Generate Reports**) can now be generated using custom classifications by selecting **CUSTOM** from the classification list and filling in the name field. SF06301702/SEG-167348/DS-76507/DSM-8
- Deep Security Manager now limits Deep Security Virtual Appliance agent software upgrades to 20.0.0 versions. Note that 20.0.1 agent versions are not supported. DSM-311
- Upgrading Deep Security Agent for a limited support platform using the Use Latest Version for an Agent option (**Computers > Details > Action > Upgrade Agent Software**) now

provides a warning that 20.0.1 agent versions are not supported for that platform. DSM-342/DSM-343/DSM-344

Resolved issues

- After upgrading to Deep Security Manager 20.0.797, the Deep Security Component Summary widget display was blank in the Apex Central console. DSM-236
- Overrides for Application Control Trust Entities settings were not being removed after using **Remove** or **Remove All** (from **Computer** or **Policy > Overrides**). DSM-120
- SAP scans generated Get Events Failed errors when **Alert for all rules (Regardless of rule settings)** was enabled (**Alerts > Alert Configuration > Anti-Malware Alert > Alert Information > Options**). SF05087843/SEG-173393/DS-77098/DSM-28
- Deep Security Manager API searches using the `greater than` parameter sometimes returned incorrect results. DSM-325
- The **Schedule Agent Upgrade** screen sometimes displayed incorrect agent versions until Deep Security Manager was restarted. DSM-329

Known issues

- Upgrading to Deep Security Agent 20.0.0-7943, 20.0.0-8137, 20.0.0-8268, or 20.0.0-8438 sometimes fails when Firewall, Web Reputation Service, or Intrusion Prevention System are enabled for Deep Security Manager. DSM-473

Deep Security Manager - 20.0.854 (20 LTS Update 2023-11-15)

Release date: November 15, 2023

Build number: 20.0.854

New Features

- Deep Security Manager now supports strong cipher suites when FIPS mode is enabled. DSM-211

Enhancements

- Deep Security Manager now supports the 20.0.1 Deep Security Agent versioning revision planned for January 2024. DSM-121

Resolved issues

- Using an Intrusion Prevention event containing a long note triggered an error with a message "Get Events Failed (Internal Server Error)". DSM-327
- The HostName lookup got stuck in some environments where the DNS setting was incomplete. DSM-307

Security updates

Security updates are included in this release. For more information about how Trend Micro protects against vulnerabilities, visit [Vulnerability Responses](#). Note that in line with responsible disclosure practices, CVE details are only made available for select security updates once patches have been made available for all impacted releases. VRTS-11238/DSM-290

Highest CVSS: 7.5

Highest severity: High

Known issues

- Upgrading to Deep Security Agent 20.0.0-7943, 20.0.0-8137, 20.0.0-8268, or 20.0.0-8438 sometimes fails when Firewall, Web Reputation Service, or Intrusion Prevention System are enabled for Deep Security Manager. DSM-473

Deep Security Manager - 20.0.844 (20 LTS Update 2023-10-18)

Release date: October 18, 2023

Build number: 20.0.844

New Features

- Deep Security Manager now allows users to configure the agent Manual Scan from policy. DSM-16

Enhancements

- In Events & Reports, the advanced search can now filter Intrusion Prevention events by "Flow" value.
The "Flow" field is now added to Intrusion Prevention syslog events. SF06798790/SEG-177960/DS-77724/DSM-9

- Application Control global block by hash rules can now be configured using a MD5 or SHA-1 file hash. (Previously, only SHA-256 could be used.) SEG-108464/DS-74144/DSM-18
- Application Control Trust Entities rules that use the process name property can now be configured using wildcards in the Deep Security Manager UI. DS-75316/DSM-18
- Trust Entities process name properties can now use Universal Naming Convention (UNC) paths to files or peripheral devices on a local area network. DS-77133/DSM-18
- Trust Entities "Allow by target" rules can now use the process name property. DS-77364/DSM-18

Resolved issues

- When configuring Role Properties, applying changes to the "Clear Warnings/Errors for" permission under the Computer Rights tab displayed the incorrect result in the console. DSM-195
- Application Control shared rulesets sometimes triggered policy updates to systems that did not support Application Control. DS-76766/DSM-18
- Software auto-authorized on agents by a Trust Entities rule are no longer automatically added to the shared rulesets. This will prevent software from remaining authorized if the corresponding trust entities rule is no longer applied. DS-74855/DSM-18

Known issues

- Deep Security Notifier may fail to start when deployed as an Anti-Malware Protected Process Light (AM-PPL) in Windows. As a workaround, deploying the Notifier as an AM-PPL has been disabled by default. See [KB000295433](#). DSM-297

Deep Security Manager - 20.0.833 (20 LTS Update 2023-09-20)

Release date: September 20, 2023

Build number: 20.0.833

Enhancements

- The permission to clear warnings and errors "canClearWarningsAndErrors" can now be granted separately to roles. SF06516228/SEG-168657/DS-77463

- Changed the error message displayed when a user that doesn't have the necessary permissions tries to edit Device Control settings. SEG-180964/C1WS-14961/DSM-56
- Some default values for Real Time Anti-Malware configuration have changed: DS-77469/C1WS-13588/DSM-36
 - Predictive Machine Learning: Pass > **Quarantine**
 - Windows Antimalware Scan Interface (AMSI): Pass > **Terminate**
- When creating a Smart Folder, vCenter Power State is now a **Computer Property** option. DSM-6/DS-77643
- Smart Folder **Computer Property** options are now sorted in alphabetical order. DSM-6/DS-77643

Resolved issues

- In the web console, AIX 7.3 agents did not display the OS version in the **Platform** field. DS-72424/DSM-128
- The **User Management > Roles > Role Properties** window did not load if a lot of computers were protected. SEG-170672/DS-76826/C1WS-12373/DSM-10
- The SHA256 hash value of files will now be included in SNS Anti-Malware events when SHA256 is selected in **Anti-Malware > Advanced > File Hash Calculation**. SEG-168652/DS-76448/C1WS-14048/DSM-7
- Deep Security Manager sometimes set a wrong date for Next Run Time while running the scheduled task, which lead to a Java DateTimeException and display of an internal server error. This could prevent the reservation task from working properly. SF07190612/SF07191522/SEG-192240/SEG-192321/DSM-169

Security updates

Security updates are included in this release. For more information about how Trend Micro protects against vulnerabilities, visit [Vulnerability Responses](#). Please note, in line with responsible disclosure practices, CVE details will only be made available for select security updates once patches have been made available for all impacted releases. VRTS-10326/DSM-158

Highest CVSS: 6.1

Highest severity: Medium

Deep Security Manager - 20.0.817 (20 LTS Update 2023-08-23)

Release date: August 23, 2023

Build number: 20.0.817

Enhancements

- The Deep Security Manager console now shows more information on the status of the Trend Micro LightWeight Filter Driver. DS-77465
- Add Device Control information to the Security Module Usage Report. DS-77319

Deep Security Manager - 20.0.802 (20 LTS Update 2023-07-19)

Release date: July 19, 2023

Build number: 20.0.802

Enhancements

- Updated Deep Security Manager to add SQL Server 2022 database support. SF06543523/SEG-169639/SEG-171432/DS-76501
- If the computer is a Podman Host, computer details now display the Podman version. DS-76683

Resolved issues

- When creating a new Scheduled Task, the "Next Run Time" value displayed in the Scheduled Task list was incorrect. SF06593263/SEG-171126/DS-76900
- Upgrade Agent Software actions would sometimes fail on Amazon Linux platforms. DSM-14
- Deep Security Manager would sometimes fail to synchronize to a Vision One Service Gateway. SF06928392/SEG-182692/DSM-19

Security updates

Security updates are included in this release. For more information about how Trend Micro protects against vulnerabilities, visit [Vulnerability Responses](#). Please note, in line with responsible disclosure practices, CVE details will only be made available for select security

Trend Micro Deep Security On-Premise 20

updates once patches have been made available for all impacted releases. VRTS-6038/DSM-32/DSM-55

Highest CVSS: 7.5

Highest severity: High

Deep Security Manager - 20.0.789 (20 LTS Update 2023-06-28)

Release date: June 28, 2023

Build number: 20.0.789

New Features

Trend Vision One Inventory support: Deep Security Manager integration with Vision One now supports Endpoint Inventory, Inventory Group, and Inventory Compliance.

Enhancements

- Deep Security Manager now supports PostgreSQL 14. SF06514546/SEG-169342/DS-76494
- Deep Security Manager now supports AWS Aurora PostgreSQL 14. DS-77594
- Deep Security Manager now supports VMware Cloud Director 10.4. SEG-152378/DS-74227
- Deep Security Manager now supports AWS RDS PostgreSQL 14. DS-76494

Resolved issues

- The Deep Security Manager console sometimes froze when opening the agent migration pop-up window. SEG-180945/DS-78114

Security updates

Security updates are included in this release. For more information about how Trend Micro protects against vulnerabilities, visit [Vulnerability Responses](#). Please note, in line with responsible disclosure practices, CVE details will only be made available for select security updates once patches have been made available for all impacted releases. VRTS-9496/DS-77146

Highest CVSS: 4.3

Highest severity: Medium

Deep Security Manager - 20.0.768 (20 LTS Update 2023-05-17)

Release date: May 17, 2023

Build number: 20.0.768

New Features

Device Control: Deep Security Manager version 20.0.768 and later now supports Device Control for Windows Server platforms, helping to protect external storage devices connected to protected endpoints. This requires Deep Security Agent 20.0.0.6313 or later. For information, see [Supported features by platform](#).

Resolved issues

- Deep Security Manager sometimes generated Tenant reports containing incorrect information for Deep Security Agents running in a multi-tenant environment. SF06301702/SEG-162798/DS-76311
- Deep Security Manager's dashboard sometimes failed to include events within the status and event history widgets. SF06492268/SEG-168155/DS-76201

Deep Security Manager - 20.0.759 (20 LTS Update 2023-04-19)

Release date: April 19, 2023

Build number: 20.0.759

Enhancements

- Agent Version Control is now available when configuring agent upgrade Scheduled Tasks. SF06094463/SEG-159727/DS-74710
- Due to product name changes, all mentions of Trend Micro Vision One were changed to Trend Vision One. DS-76215

Resolved issues

- Under certain conditions, Deep Security events would incorrectly report that 'The component "Advanced Threat Scan Engine" has been removed'. SF05801044/SEG-

147779/DS-75232

- Some lists in the management console were causing performance issues in environments with more than 50,000 hosts. SF05874881/SEG-149417/DS-72746
The affected lists include, but are not limited to, the lists under System Event, Computer, Single Report, Scheduled Reports, Scheduled Task, Alert, and Dashboard.

Deep Security Manager - 20.0.741 (20 LTS Update 2023-03-15)

Release date: March 15, 2023

Build number: 20.0.741

New Features

Service Gateway: Deep Security Manager version 20.0.741 and later now supports Service Gateway, providing forward proxy functionality.

Deep Security Manager - 20.0.737 (20 LTS Update 2023-02-23)

Release date: February 23, 2023

Build number: 20.0.737

Enhancements

- Deep Security Manager 20.0.737 and later now supports Red Hat Enterprise Linux 9 (64-bit). SF06130289/SEG-157410/DS-74295
- Deep Security Manager now enforces certificate updates to RSA-2048 and SHA-256 for agents using unsupported certificates. Deep Security Agent version 20.0.0-6313 and later does not support SHA-1) For more details, see [Upgrade the Deep Security cryptographic algorithm](#). DS-76297
- Updated Deep Security Manager to add API Smart Folder functionality. DS-75375

Security updates

Security updates are included in this release. For more information about how Trend Micro protects against vulnerabilities, visit [Vulnerability Responses](#). Please note, in line with responsible disclosure practices, CVE details will only be made available for select security updates once patches have been made available for all impacted releases. DS-75668/DS-75924

Highest CVSS: 8.1

Highest severity: High

Deep Security Manager - 20.0.725 (20 LTS Update 2023-01-18)

Release date: January 18, 2023

Build number: 20.0.725

Resolved issues

- Updated Deep Security Manager to include an OS (operating system) field for syslog forwarding if `settings.configuration.addPlatformInSyslogMessage` is set to true by console command. For more information, see <https://success.trendmicro.com/solution/000289535>. DS-73163

Security updates

Security updates are included in this release. For more information about how Trend Micro protects against vulnerabilities, visit [Vulnerability Responses](#). Please note, in line with responsible disclosure practices, CVE details will only be made available for select security updates once patches have been made available for all impacted releases. DS-74793

Highest CVSS: 7.5

Highest severity: High

Deep Security Manager - 20.0.716 (20 LTS Update 2022-12-15)

Release date: December 15, 2022

Build number: 20.0.716

Resolved issues

- When exporting the list of computers to CSV, the Docker Host and CRI-O Host field value was not included correctly. SF05232601/SEG-131041/DS-73391
- The Deep Security Manager would report Rocky Linux 8 as an unknown Linux OS when registered through the AWS connector. DS-71999

Deep Security Manager - 20.0.711 (20 LTS Update 2022-11-16)

Release date: November 16, 2022

Build number: 20.0.711

Enhancements

- Updated Deep Security Manager to include Project ID for computers using Google Cloud Platform. SF05811253/SEG-147466/DS-72694

Security updates

Security updates are included in this release. For more information about how Trend Micro protects against vulnerabilities, visit [Vulnerability Responses](#). Please note, in line with responsible disclosure practices, CVE details will only be made available for select security updates once patches have been made available for all impacted releases. DS-74218

Highest CVSS: 7.5

Highest severity: High

Deep Security Manager - 20.0.703 (20 LTS Update 2022-10-19)

Release date: October 19, 2022

Build number: 20.0.703

Enhancements

- With Multi-Factor Authentication enabled, changing an account password now requires verifying the user's MFA code (in addition to the user's old password). DS-73341
- Updated Deep Security Manager to notify users of trust entity ruleset changes in the computer's status bar. DS-70956
- Updated Deep Security Manager to allow using question marks in Application Control trust rule `paths` property fields to match a single additional character in the path. DS-71604
- Updated the Deep Security Manager's UI tooltip for trust entity rules to describe the latest wildcard functionality. DS-69964
- Updated Deep Security Manager to use the latest Simple Object Access Protocol (SOAP) components to protect against vulnerabilities affecting older versions. DS-73080

Resolved issues

- Reports generated by Deep Security Manager (**Events & Reports > Generate Reports**) did not display Chinese language characters properly. SF05883379/SEG-149459/DS-72858
- Anti-Malware events sometimes displayed a blank file path with invalid Unicode encoding. 01746052/SEG-46912/DSSEG-3653
- Application Control rule permissions configured by administrators did not result in the corresponding functionality for users. As examples, a rule with its permissions set to Hide was still visible to users, and one with a Custom configuration preventing users from creating new rules did not prevent them from doing so. DS-68693
- In Trust Entity Management (**Policies > Common Objects > Application Control Rules > Trust Entities**), the horizontal scroll bar in the **Edit Trust Ruleset** window was covering rules displayed at the bottom of the window. DS-70435

Deep Security Manager - 20.0.686 (20 LTS Update 2022-09-21)

Release date: September 21, 2022

Build number: 20.0.686

Resolved issues

- If an Application Control shared ruleset was successfully created on a Deep Security Agent using the API, creating another shared ruleset with the API on the same agent would fail. DS-71034
- Deep Security Manager sometimes displayed the wrong state for items in an Anti-Malware Report (**Events & Reports > Generate Reports**). SF05780825/SEG-149707/DS-72871
- With Perform Ongoing Recommendation Scans set to Yes and an Ongoing Scan Interval set to 4 Weeks (**Computer or Policy > Settings > General > Recommendations**), Deep Security Manager executed the scans much more frequently than the set interval. SF05658685/SEG-148153/DSSEG-7707

Deep Security Manager - 20.0.677 (20 LTS Update 2022-08-17)

Release date: August 17, 2022

Build number: 20.0.677

New Features

Windows Server 2022 support: Deep Security Manager version 20.0.677 and later now supports Windows Server 2022.

Enhancements

- Updated Deep Security Manager to encrypt user login details. DS-71448

Resolved issues

- Under **Events & Reports > Firewall Events**, when using Action and Contains filters to search for Fail Open: Deny, the search results failed to display matching events. SF05740930/SEG-146282/DS-72636
- VMware vCloud accounts missing their OS type caused synchronization to fail. SF05830546/SEG-147983/DS-72518
- VMware vCloud connectors with more than 25 Virtual Data Centers only displayed 25 in Deep Security Manager. SEG-147252/DS-72376
- When Deep Security Relay were rehomed to a vCenter connector, they lost their original hostname in Deep Security Manager. SF05519505/SEG-140015/DS-72596
- Deep Security Manager sometimes generated unexpected Computer Updated system events. SF05496967/SEG-138407/DSSEG-7672

Deep Security Manager - 20.0.664 (20 LTS Update 2022-07-21)

Release date: July 21, 2022

Build number: 20.0.664

Enhancements

- Updated Deep Security Manager to include port 443 by default (along with ports 80 and 8080) for Ports to Monitor for Potentially Harmful Web Pages (**Computer** or **Policy > Web Reputation > Advanced**). This change prepares Web Reputation SSL inspection support on port 443 for future (not yet released) Deep Security Agent versions.
- Updated Deep Security Manager to add the `-disablemfa` parameter. This parameter allows users to disable Multi-factor authentication (MFA) when using the `dsm_c` command line to perform a password reset. DS-69590

Resolved issues

- Deep Security Manager was sometimes unable to synchronize with Microsoft Active Directory (AD) users. SEG-138257/SF05452498/DS-70873

Security updates

Security updates are included in this release. For more information about how Trend Micro protects against vulnerabilities, visit [Vulnerability Responses](#). Please note, in line with responsible disclosure practices, CVE details will only be made available for select security updates once patches have been made available for all impacted releases. DS-71624

Highest CVSS: 9.8

Highest severity: Critical

Deep Security Manager - 20.0.651 (20 LTS Update 2022-06-15)

Release date: June 15, 2022

Build number: 20.0.651

Enhancements

- Updated Deep Security Manager to provide more information for Anti-Malware Engine Offline events, including an ID indicating the event's cause and a link in the description leading to recommended actions. Also, a system log entry for the event is now generated if SIEM is enabled. DS-70595
- Updated Deep Security Manager to save disk space by removing outdated versions of the agent installer package. DS-67840
- Updated Deep Security Manager to trigger event based tasks related to creating a computer when adding an active directory computer with the "Add Active Directory" wizard. DS-68877
- Updated Deep Security Manager to remove support for 8.0 and 9.0 Deep Security Agents, since these versions are past their EOL dates. For more information, see [Deep Security LTS life cycle dates](#). DS-70332

Deep Security Manager - 20.0.644 (20 LTS Update 2022-05-18)

Release date: May 18, 2022

Build number: 20.0.644

Resolved issues

- Some rules did not display properly in Deep Security Manager when columns were sorted By Group (under **Policies > Common Objects > Rules** or under **Computers > Computers**). SEG-127353/DS-68348
- Agent activation sometimes became stuck in a loop which caused high memory consumption for Deep Security Manager. DS-71234

Security updates

Security updates are included in this release. For more information about how Trend Micro protects against vulnerabilities, visit [Vulnerability Responses](#). Please note, in line with responsible disclosure practices, CVE details will only be made available for select security updates once patches have been made available for all impacted releases. DS-71244/DS-65171

Highest CVSS: 7.5

Highest severity: High

Deep Security Manager - 20.0.635 (20 LTS Update 2022-04-21)

Release date: April 21, 2022

Build number: 20.0.635

New Features

Advanced TLS traffic inspection: Deep Security Manager now provides an option to configure advanced TLS traffic inspection, removing the need to configure TLS credentials manually and adding support for more ciphers. You can verify the status of the feature by viewing the policy properties (Policy > Intrusion Prevention > General > Advanced TLS Traffic Inspection). For more information, see [Enable Advanced TLS traffic inspection](#).

Azure and GCP connector migration support: Azure and GCP (Google Cloud Platform) connectors can now be migrated from Deep Security Manager to Trend Micro Cloud One - Workload Security. For more information, see [Migrate cloud accounts to Workload Security](#).

Resolved issues

- Deep Security Manager was not receiving the number associated with systemEventID errors for system configurations using Simple Network Management Protocol (SNMP). SEG-122864/04711592/DS-67387
- Intrusion Prevention events containing number strings, such as IP addresses, sometimes resulted in Get Events Failed `NumberFormatException` errors in Deep Security Manager. SEG-120226/SF04838989/DSSEG-7216
- Deep Security Manager was sometimes unable to sync with vCloud. SEG-135846/SF05409802/DS-70336
- Deep Security Manager did not properly display Computer Moved events. DS-70669
- When a Deep Security Agent with an existing Application Control local ruleset was removed from Deep Security Manager, the ruleset for that agent still appeared in the manager (under **Policies > Application Control Rules > Software Rulesets**). DS-68173
- If the REST API was used to select the `critical-and-heuristic` parameter for Document Exploit Protection, Deep Security Manager would not display that selection for the malware scan configuration (under **Computer or Policy > Anti-Malware > General > Edit**). DS-67975

Deep Security Manager - 20.0.619 (20 LTS Update 2022-03-22)

Release date: March 22, 2022

Build number: 20.0.619

New Features

FIPS mode for Amazon Linux 2: Deep Security Manager version 20.0.619 and later now supports FIPS mode for AWS Marketplace deployment. This is supported for Deep Security Agent version 20.0.0-2971 and later.

Enhancements

- Updated Deep Security Manager to use the term *protected* instead of *anonymous* when referring to Trend Micro Feedback being shared with the Smart Protection Network. DS-70101

Resolved issues

- Deep Security Manager failed to migrate policies to Trend Micro Cloud One - Workload Security if a module's license had expired. DS-69595
- In a Security Module Usage Cumulative Report (**Events & Reports > Generate Reports**), Application Control usage hours were not being included properly under System Usage hours. DS-67494
- The Deep Security Manager Trust Entities **New Ruleset** window (**Trust Entities > Trust Ruleset > New**) had its **OK** and **Close** buttons blocked on some screen resolutions. DS-68838
- Behavior Monitoring status of Deep Security Agents for Linux was inconsistent on Deep Security Manager versions later than 20.0.312. With Behavior Monitor detection disable, the manager console sometimes still showed that it was enabled under the default settings for Anti-Malware real-time or advanced real-time scans. DS-69536
- There was a connectivity issue when a Deep Security Agent had FIPS mode enabled but Deep Security Manager did not. DS-70038

Security updates

Security updates are included in this release. For more information about how Trend Micro protects against vulnerabilities, visit [Vulnerability Responses](#). Note that in line with responsible disclosure practices, CVE details are only made available for select security updates once patches have been made available for all impacted releases. SEG-132505/SF05278860/DS-69608/DS-69764

Highest CVSS: 9.8

Highest severity: Critical

Deep Security Manager - 20.0.605 (20 LTS Update 2022-02-16)

Release date: February 16, 2022

Build number: 20.0.605

Enhancements

- Updated Deep Security Manager to allow users to toggle real time container protection (from **Computer** or **Policy Settings > General**). This setting is enabled by default. SEG-

115751/DS-68963

Resolved issues

- Filtering Smart Folders by Folder Name sometimes displayed results for folders or groups that no longer existed. SEG-120786/SF04858677/DSSEG-7220
- With event-based task settings enabled for NSX Security Group Change (**Administration > Event-Based Tasks**), Deep Security Manager would trigger auto-activation of a virtual machine if it was removed from an NSX Security Group. DS-36694
- Deep Security Manager displayed the wrong description for Move Failed (No Response) system events. DS-69407

Security updates

Security updates are included in this release. For more information about how Trend Micro protects against vulnerabilities, visit [Vulnerability Responses](#). Note that in line with responsible disclosure practices, CVE details are only made available for select security updates once patches have been made available for all impacted releases. VRTS-5866/DS-62223

Highest CVSS: 8.2

Highest severity: High

Deep Security Manager - 20.0.585 (20 LTS Update 2022-01-17)

Release date: January 17, 2022

Build number: 20.0.585

New Features

Application Control Trust Entities: This feature lets you configure trust rules to auto-authorize software changes in your environments, reducing the number of software changes and security events you need to manage manually. For details, see [Application Control Trust Entities](#).

Enhancements

- **Migrating to Trend Micro Cloud One - Workload Security:**
 - Deep Security Manager includes a new `commonobjectmigrationtask` API and UI for migrating common objects (with the exception of rules and malware configurations)

to your Workload Security account.

- Deep Security Manager includes a new `connectormigrationtasks` API and UI for migrating AWS accounts that are connected to your Deep Security Manager into your Workload Security account.
- Deployment scripts used to install Trend Micro Endpoint Basecamp (required to [forward security events to Trend Micro Vision One](#)) have been updated with a new certificate issuer organization name.

Resolved issues

- Moving Deep Security Agents to Workload Security would fail if Deep Security Manager was configured with a proxy that doesn't require authentication credentials. DS-68710

Security updates

Security updates are included in this release. For more information about how Trend Micro protects against vulnerabilities, visit [Vulnerability Responses](#). Note that in line with responsible disclosure practices, CVE details are only made available for select security updates once patches have been made available for all impacted releases. DS-68725, DS-67244

Highest CVSS: 9.1

Highest severity: Critical

Deep Security Manager - 20.0.560 (20 LTS Update 2021-12-16)

Release date: December 16, 2021

Build number: 20.0.560

New Features

Trusted Certificates Detection Exceptions: Deep Security Manager version 20.0.560 and later now allows you to configure Trusted Certificates Detection Exceptions (from a policy's **Details & Anti-Malware & Advanced** tab) to exclude files from Anti-Malware scanning based on their digital certificate. This is currently supported for Deep Security Agent version 20.0.0-3445 and later on Windows platforms only. For more information, see [Exclude files signed by a trusted certificate](#).

Resolved issues

- Deep Security Manager was unable to retrieve security settings from groups containing more than 1000 computers. SF05006314/SEG-124719/DS-67938
- Deep Security Manager was sending suspicious objects to Deep Security Agent even after the objects' expire time had ended. DS-67917
- Deep Security Manager was not displaying virtual machines that had been upgraded to VMware Cloud Director 10.3 or 10.3.1, even though they were still connected. SEG-123585/SF04968350/DS-67513

Security updates

Security updates are included in this release. For more information about how Trend Micro protects against vulnerabilities, visit [Vulnerability Responses](#). Note that in line with responsible disclosure practices, CVE details are only made available for select security updates once patches have been made available for all impacted releases. DS-68162/DS-65579

Highest CVSS: 7.5

Highest severity: High

Deep Security Manager - 20.0.543 (20 LTS Update 2021-11-18)

Release date: November 18, 2021

Build number: 20.0.543

Enhancements

- Updated Deep Security Manager to hide the Trend Micro Vision One promotion banner for 24 hours after being dismissed by a user. DS-55349
- You can now use Azure application certificate authentication when adding an Azure connector. For details, see "[Add a Microsoft Azure account to Deep Security](#)" on page 665. DS-63762
- Improved migration from Deep Security Manager to Workload Security in the following ways:
 - Updated Deep Security Manager to handle connectivity issues better during migration to Workload Security, preventing the console UI from being blocked or stuck in a

loading loop. DS-67841

- Updated Deep Security Manager so that the Computer Group list for Deep Security Agents being migrated to Workload Security no longer displays computer groups generated by connectors. DS-67776
- Updated Deep Security Manager Move Failed system events to include additional event details from the Workload Security side. DS-67921
- Updated Deep Security Manager to check for inactivated computers with the same hostname as computers being migrated to Workload Security. If a matching hostname is found, the manager now updates the existing computer instead of marking the task as Move Failed. DS-67527
- Updated Deep Security Manager's policy migration page (**Support > Migrate to Workload Security > Configurations**) to note that Rule Updates must be up to date before migration, and that common objects in Workload Security are overwritten if they have the same name as migrated objects. DS-67777
- Updated Deep Security Manager to remove the Migrate to Workload Security option (shown when right-clicking a computer) for computers that are not migratable. DS-67666

Resolved issues

- Software Update sometimes failed if the kernel support package and the agent installer were both the same version. DS-67547
- Deep Security Manager system events sometimes had No Description in the description field. DS-66878
- Deep Security Manager sometimes received alerts for agents that had not been activated. DS-64523
- After an update, Deep Security Manager kept a copy of the previous version's online help files. SEG-120770/SF04858311/DS-66969
- In Deep Security Manager's **Computers** tab, the LAST COMMUNICATION column sometimes did not sort correctly. SEG-120751/SF04862693/DS-67579
- Deep Security Manager was unable to migrate agent/appliance initiated agents (AIA) with certain configurations over to Workload Security. SEG-124938/DS-67861
- When the Migrate With Settings Overridden at Computer Level option was selected, Deep Security Manager incorrectly tried to migrate rule assignments, which could cause the migration to Workload Security to fail. DS-67528

- For Deep Security Managers using an Oracle Database, any computers requesting migration to Workload Security would have their status show Moving even if the migration was successful. DS-67930
- Deep Security Manager sometimes encountered a runtime exception that would prevent computers from moving to Workload Security during migration. DS-67932

Deep Security Manager - 20.0.513 (20 LTS Update 2021-10-14)

Release date: October 14, 2021

Build number: 20.0.513

New Feature

Migrate to Workload Security using the Deep Security Manager UI: Deep Security Manager now supports moving agents and policy configurations to Trend Micro Cloud One Workload Security using the Deep Security Manager UI. This includes the following:

- Migrate agents using the UI
- Migrate configurations using the UI
- Migrate agents with settings overridden at the computer level
- Move multiple agents at the same time with a single BatchComputerMoveTask API call

For more information, see [Migrate to Workload Security](#).

Resolved issues

- While syncing Trend Micro Vision One (XDR) status, Deep Security Manager sometimes failed to synchronize the Sandbox as a Service status at the same time. DS-66122

Deep Security Manager - 20.0.503 (20 LTS Update 2021-09-23)

Release date: September 23, 2021

Build number: 20.0.503

New Feature

Control kernel package updates: This update introduces a new way to manage your kernel support packages. Deep Security Manager now provides an option to automatically update the

kernel package when an agent restarts on Linux. For details, see "[Disable optional Linux kernel support package updates](#)" on page 350.

Enhancements

- Updated Deep Security Manager to integrate with Trend Micro Vision One for [Threat Intelligence](#) (previously known as Connected Threat Defense). DS-61106
- Updated Deep Security Manager to allow the removal of Integrity Monitoring baseline data using a console (dsm_c) command. Removing baseline data does not affect the protection you receive from Integrity Monitoring, but does remove the following:
 - The option to View Baseline data from the manager console
 - The ability to use Trusted Common Baseline as a source of Auto-Tagging
 - The ability to generate an Integrity Monitoring Baseline Report

As baselines have grown larger and workloads have become more dynamic, the ability to support the Integrity Monitoring baseline in the Deep Security Manager console has become increasingly challenging. We are committed to evolving the design of Integrity Monitoring to meet the performance and operational needs of our customers. Through discussions with our customers, it was determined that in its current form, Integrity Monitoring was not always delivering the value to offset the performance and operational overhead required to maintain baseline data. For more details on disabling baseline data see [000289069](#). DS-60498

Resolved issues

- Deep Security Agent automatic upgrades sometimes failed if Deep Security Manager had Upgrade on Activation and Event-based Tasks enabled at the same time. SEG-105646/SF04249597/DS-62190
- The Deep Security Manager console command to add a trusted certificate sometimes failed for LDAPS server certificates. SEG-116063/SF04716472/DS-65277
- Some API key fields used to [migrate to Workload Security](#) were missing from the [Workload Security Links](#) API document. DS-66022
- In environments with multiple vCenter connectors undergoing frequent vMotion, Deep Security Manager sometimes encountered a deadlock causing Engine Offline errors for Anti-Malware, Firewall, and Intrusion Prevention. SEG-115729/SF04696226/DS-65311
- Deep Security Manager sometimes couldn't retrieve a computer's information, causing VMware NSX synchronization to fail. SEG-117202/DS-65610

- Deep Security Virtual Appliance IPv6 addresses sometimes displayed in the Deep Security Manager console even if the IPv6 was not available in the environment. SEG-118810/SF04806948/DS-66263
- Deep Security Manager Scheduled Reports (**Events & Scheduled Reports**) with a Using Policy computer filter sometimes still showed all computers in the generated reports. SF04676734/SEG-116345/DS-65336
- Deep Security Agent upgrade failures sometimes occurred if Default Real-Time Scan File List or Directory List exclusions were created with duplicate names in Deep Security Manager. DS-65746

Security updates

Security updates are included in this release. For more information about how Trend Micro protects against vulnerabilities, visit [Vulnerability Responses](#). Note that in line with responsible disclosure practices, CVE details are only made available for select security updates once patches have been made available for all impacted releases. VRTS-5934/DS-63325/DS-65607

Highest CVSS: 7.5

Highest severity: High

Deep Security Manager - 20.0.482 (20 LTS Update 2021-08-25)

Release date: August 25, 2021

Build number: 20.0.482

Enhancements

- Updated Deep Security Manager to support PostgreSQL 12 and PostgreSQL 13 in FIPS mode. For more information see [FIPS 140-2 support](#). DS-63876
- Updated Deep Security Manager's Workload Security Link API to support URLs containing "https" when attempting to [Migrate to Workload Security](#). DS-65095

Resolved issues

- Deep Security Manager Scheduled Tasks (**Administration > Scheduled Tasks**) configured to run daily would sometimes run hourly. SEG-108098/DS-64247

- In Deep Security Manager's Computers page, the LAST MANUAL SCAN FOR MALWARE and LAST SCHEDULED SCAN FOR MALWARE columns sometimes did not sort properly.
- Tenants were sometimes unable to update their license if the primary tenant enabled a proxy server with credentials (**Administration > System Settings > Proxies > Deep Security Manager (Software Updates, CSSS, News Updates, Product Registration and Licensing)**).

Security updates

Security updates are included in this release. For more information about how Trend Micro protects against vulnerabilities, visit [Vulnerability Responses](#). Note that in line with responsible disclosure practices, CVE details are only made available for select security updates once patches have been made available for all impacted releases. VRTS-5932/DS-63442/DS-51695/VRTS-5930/DS-63071/VRTS-5929/DS-63072

Highest CVSS: 6.5

Highest severity: Medium

Deep Security Manager - 20.0.463 (20 LTS Update 2021-07-22)

Release date: July 22, 2021

Build number: 20.0.463

Enhancements

- Updated Deep Security Manager to include two different action options in the Anti-Malware Scan Interface (AMSI): Customers can now select either Pass or Terminate. DS-63691
- Updated Deep Security Manager to support migrating policies to Workload Security using the new MigratePolicy API command. This command automates the process of migrating the Deep Security Policies from their current on-premise manager to a Cloud One Workload Security tenant. DS-63316
- Updated Deep Security Manager to check if the virtual machine's IP address is reachable during the rehomings process for vCenter. DS-63514

Resolved issues

- Deep Security Manager was sometimes unable to send emails on systems with more than one network interface card (NIC). DS-63254
- Deep Security Agents using agent-initiated activation (AIA) sometimes went offline following a certificate update. DS-58106
- When generating an Agent Version Report (**Events & Reports > Generate Reports**), the report generated as if All Computers was selected in the Computer Filter section regardless of which option was actually selected. DS-64133
- Filtering a Smart Folder by Tag was not working properly for new events added with Auto-Tagging (**Events & Reports > Events > (Select an event type) > Auto-Tagging**). DS-61210
- When a virtual machine (on vCenter) had multiple IP addresses, Deep Security Manager was sometimes unable to select the correct IP address. SEG-109694/SF04486485/DS-63235
- Deep Security Manager would sometimes re-download an outdated Kernel Support Package (KSP) that had previously been deleted. SEG-101335/04121383/DS-60849

Security updates

Security updates are included in this release. For more information about how Trend Micro protects against vulnerabilities, visit [Vulnerability Responses](#). Note that in line with responsible disclosure practices, CVE details are only made available for select security updates once patches have been made available for all impacted releases. DS-64012/VRTS-5931/DS-63070

Highest CVSS: 6.8

Highest severity: Medium

Deep Security Manager - 20.0.447 (20 LTS Update 2021-06-28)

Release date: June 28, 2021

Build number: 20.0.447

New Feature

Re-parent agents: Deep Security Manager now supports moving agents to Trend Micro Cloud One Workload Security using the new MoveAgent API command. This command automates the

process of re-parenting an activated Deep Security Agent from its current on-premise manager to a Workload Security tenant. If re-parenting is unsuccessful, the agent will re-activate with its on-premise manager, retaining its previous configuration.

Due to feature differences between the Deep Security and Workload Security managers, move tasks may be refused to prevent unexpected behaviors. You should disable the following before moving agents:

- [FIPS 140-2](#): Deep Security Manager will refuse move tasks if FIPS 140-2 support is enabled.
- [Deep Security Virtual Appliance \(agentless or combined mode\)](#): Computers protected by Deep Security Virtual Appliance (agentless or combined mode) will refuse move tasks.
- [SAP NetWeaver integration](#): Agents with SAP NetWeaver integration will accept move tasks. However, after being moved to Workload Security, the SAP NetWeaver integration will not be available until it is supported on Workload Security.

Enhancements

- Updated Deep Security Manager to add PostgreSQL 12 and PostgreSQL 13 database support. DS-59911
- Removed the Windows logo that was displayed next to Predictive Machine Learning in the Deep Security Manager UI. Predictive Machine Learning is currently supported by all Windows agents, as well as Linux agents version 20.0.0-2395 and later. DS-62929
- Updated Deep Security Manager to note which agent versions support Behavior Monitoring Pass action: Deep Security Agent 20.0.0-1559 and later on Windows and Deep Security Agent 20.0.0-1822 and later on Linux. DS-62937
- Updated the Activity Data Forwarding description (**Administration > System Settings > Trend Micro Vision One**) to provide more information on script deployment. DS-63278
- Updated the Endpoint Basecamp deployment script (**Administration > System Settings > Trend Micro Vision One > Activity Data Forwarding**) to improve support on some platforms, and updated script deployment error messages to be more descriptive. SEG-109629/DS-63157

Resolved issues

- In Deep Security Manager's **Tenants** page (**Administration > Tenants**), some columns were being sorted based only on the first digit of the number of events or jobs, instead of being sorted based on the entire number. SEG-107657/DS-62544

- Deep Security Manager had high memory consumption when querying databases with a large number of security profiles. SEG-103097/SF04265571/DS-61490
- Anti-Malware Real-Time Scan Configuration policies sometimes did not reset to their inherited value properly. DS-63835
- System event messages sometimes contained information referencing the wrong operating system. SF04443281/SEG-111629/DS-64089

Security updates

Security updates are included in this release. For more information about how Trend Micro protects against vulnerabilities, visit [Vulnerability Responses](#). Note that in line with responsible disclosure practices, CVE details are only made available for select security updates once patches have been made available for all impacted releases. DS-63110/DS-61049

Highest CVSS: 5.8

Highest severity: Low

Deep Security Manager - 20.0.414 (20 LTS Update 2021-05-24)

Release date: May 24, 2021

Build number: 20.0.414

Enhancement

- Updated Deep Security Manager to enhance the Identified Files download mechanism, including the ability to download from agent-initiated Deep Security Agents, and a new File Status field on identified files to indicate download progress. DS-60741

Resolved issues

- Under some configurations an internal error prevented users from generating a [Deep Security Compliance / Best Practice Report](#). SF04154114/SEG-99975/DS-60897
- An account permissions issue sometimes caused Trend Micro Vision One registration to fail or display the wrong status (under **Administration > System Settings > Trend Micro Vision One**). DS-61893
- Deep Security Manager sometimes had connectivity issues preventing computers from importing properly and preventing Deep Security Relays from activating or deactivating. DS-58417

- Deep Security Manager sometimes incorrectly prevented users with an Auditor role from viewing Firewall Rules (**Policies > Rules > Firewall Rules**). SF04220398/SEG-102016/DS-60847
- Deep Security Manager links to Japanese language content failed to load in setups using an air gapped Online Help package (**Administration > Updates > Local**). 04442246/SEG-108814/DS-63080
- Deep Security Manager sometimes stopped processing scheduled tasks if the database connection was unstable. DSSEG-6689/DS-62963

Deep Security Manager - 20.0.393 (20 LTS Update 2021-04-27)

Release date: April 27, 2021

Build number: 20.0.393

Enhancements

- Updated Deep Security Manager to add a message to an event's description if the event is purged by one of the Automatically Delete Events Older Than options (**Administration > System Settings > Storage**). DS-59349
- Updated Deep Security Manager to increase the number of >Maximum TCP Connections (**Computers > Computers > Details > Settings > Advanced**) to 1000000 by default. DS-61032

Resolved issues

- Deep Security Manager version upgrade sometimes failed when a key value contained special characters. SEG-99875/SF04106715/DS-60581
- Anti-Malware Scheduled Scan was not working under some configurations. DS-54952
- The Deep Security Manager console's load time was sometimes slower than normal when many policies existed and/or were assigned to roles. SEG-90429/SF03787758/DS-58871
- The Automatically Delete Server Logs Older Than setting (**Administration > System Settings > Storage**) appeared for tenants when it should have only appeared for the primary tenant. DS-58669
- The View Renewal Instructions URL was broken in **License Properties (Administration > Licenses > View Details)**. SEG-104258/SF04308332/DS-61343

- Deep Security Manager was sometimes unable to synchronize with AWS Connectors. SEG-102091/SF04198233/DSSEG-6726
- Deep Security Manager was unable to validate credentials for some AWS connectors when their region data changed unexpectedly in the database. SEG-97924/DS-60541
- Deep Security Manager was sometimes unable to access existing Real-Time Malware Scan Configurations (**Policies > Common Objects > Other > Malware Scan Configurations**). SEG-86700/SF03646616/DS-55577
- A Data Pruning malfunction (**Administration > System Settings > Storage**) sometimes led to a large number of events, causing performance issues between the Deep Security Manager and database. SEG-97589/SF04073627/DS-61356
- System Event Reports in Deep Security Manager (**Events & Reports > Generate Reports**) were sometimes generated with data missing. DS-61752
- Deep Security Manager was sometimes unable to generate a password-protected Single Report or password-protected Scheduled Reports (**Events & Reports > Generate Reports**). SEG-105241/SF04341549/DS-61718
- Updating the password for an Azure Connector (**Computers > Computers > right-click Azure Connector > Properties > Connection**) sometimes did not work, causing the account to lose its connection to Deep Security Manager. DS-60479
- Deep Security Manager sometimes could not remove a vCenter Connector that had NSX installed. DS-61101
- Deep Security Manager's Anti-Malware Protection Status on the **Dashboard** sometimes displayed incorrect information. SEG-103625/SF04271447/DS-61598
- Application Control hours were not being calculated when generating a Security Module Usage Cumulative Report (**Events & Reports > Generate Reports**). SEG-100505/SF04174981/DS-60675

Security updates

Security updates are included in this release. For more information about how Trend Micro protects against vulnerabilities, visit [Vulnerability Responses](#). Note that in line with responsible disclosure practices, CVE details are only made available for select security updates once patches have been made available for all impacted releases. DS-51780/DS-61318

Highest CVSS: 8.2

Highest severity: Medium

Deep Security Manager - 20.0.366 (20 LTS Update 2021-03-24)

Release date: March 24, 2021

Build number: 20.0.366

New Feature

Deploy Trend Micro Endpoint Basecamp for Trend Micro Vision One (XDR): After onboarding to Trend Micro Vision One (XDR), you can now select the **Trend Micro Endpoint Basecamp Agent Deployment Script (Support > Deployment Scripts)** to automatically deploy it along with your Deep Security Agent on Linux or Windows platforms.

Enhancements

- Updated Deep Security Manager to make error messages, and the actions required to troubleshoot them, clearer during Trend Micro Vision One (XDR) registration. DS-61057

Resolved issues

- Deep Security Manager System Event Reports (**Events & Reports > Generate Reports**) sometimes had no data in the section for Most Active Computers Ranked by Number of System Events. DS-28985
- **Malware Scan Status** on the **Dashboard** sometimes displayed the wrong data. DS-57263
- Deep Security Manager's Security Updates Overview (**Administration > Updates > Security**) sometimes showed No Scheduled Task even if there was one in **Administration > Scheduled Tasks**. SEG-97381/DS-60271
- Entering certain terms in the Computers search field (in the **Computers** tab) would cause the search to fail and display an Internal server error. SEG-98108/SF03976840/DS-60133
- A user with View-Only privileges was able to make changes to Deep Security Manager's Application Control Ruleset actions. SEG-81133/03347924/DS-61041

Security updates

Security updates are included in this release. For more information about how Trend Micro protects against vulnerabilities, visit [Vulnerability Responses](#). Note that in line with responsible disclosure practices, CVE details are only made available for select security updates once patches have been made available for all impacted releases. DS-61209/VRTS-4382/03116764/DS-49429

Highest CVSS: 7.5

Highest severity: High

Deep Security Manager - 20.0.344 (20 LTS Update 2021-02-23)

Release date: February 23, 2021

Build number: 20.0.344

Enhancements

- Updated Deep Security Manager's Anti-Malware default real-time scan exclusions to enhance performance. DS-55169
- Updated Deep Security Manager UI to rename Trend Micro XDR as Trend Micro Vision One. DS-60273
- Updated Deep Security Manager to add deployment script support for CentOS 8 and RedHat 8. DS-60413
- Updated Trend Micro Vision One tab Learn More links to point to content based on the language of a user's locale (EN/JP). DS-60487
- Updated the Deep Security Software page to fix some incorrect links. DS-60494
- Updated Deep Security Manager to add 2 Days as an option for Inactive Agent Cleanup (**Administration > Agents > Inactive Agent Cleanup**). SEG-91358/SF03711833/DS-59591
- Updated Deep Security Manager to improve vCenter connectivity when a Deep Security Agent's IP is unreachable, and when Manager-Initiated communication is enabled. DS-58526
- Updated Deep Security Manager to add support for ports 32767-65535. SEG-98840/SF04119337/DS-60122
- Updated the Deep Security Manager's XDR Basecamp (XBC) deployment script UI to provide a link to the latest platform support info on the online help center. DS-60206

Resolved issues

- When a VM was managed through both the **Computers > Add Active Directory** and **Add Azure Account** options, issues with host updates and rehomeing occurred. SEG-97266/SF03911224/DS-59853
- Deep Security Manager's Anti-Malware Protection Status Widget (in the **Dashboard** tab) sometimes failed to display data. DS-48046

- Deep Security Manager integration with an SAML identity provider sometimes failed if all roles didn't match the expected format. SEG-90158/SF03783432/DS-57687

Deep Security Manager - 20.0.321 (20 LTS Update 2021-01-26)

Release date: January 26, 2021

Build number: 20.0.321

Enhancements

- Updated Deep Security Manager to display the correct deployment script when it is selected from the **Platform** menu (**Administration > System Settings > Trend Micro Vision One**). DS-59825
- Updated Deep Security Manager to support agentless mode for NSX-T on VMWare Cloud Director version 10.2 or later. DS-54044

Resolved issues

- Running multiple Check for Security Update scheduled tasks at the same time sometimes resulted in updates being skipped. DS-59715

Security updates

Security updates are included in this release. For more information about how Trend Micro protects against vulnerabilities, visit [Vulnerability Responses](#). Note that in line with responsible disclosure practices, CVE details are only made available for select security updates once patches have been made available for all impacted releases. DS-59917

Highest CVSS: 6.1

Highest severity: Medium

Deep Security Manager - 20.0.313 (20 LTS Update 2021-01-18)

Release date: January 18, 2021

Build number: 20.0.313

New Feature

Trend Micro Endpoint Basecamp Agent: Trend Micro Endpoint Basecamp (XBC) Agent integrates XDR tools and functionality into Deep Security, following Trend Micro Vision One onboarding. For more information see "[Integrate with Trend Micro Vision One \(XDR\)](#)" on [page 1901](#).

Enhancements

- Updated vCenter to make changing an NSX Manager simpler by using the **Remove NSX Manager** button (**Properties > NSX Manager**) rather than editing the **Manager Address:** field. DS-58377
- Updated the Deep Security Manager so that, by default, Trend Micro Vision One is enabled after the onboarding experience and after migrating to a paid license. DS-58788
- Removed the **News** button from Deep Security Manager. For the latest news on product changes, see [What's new?](#) DS-58808
- Aligned package naming for Deep Security Manager and Deep Security Agent on the Download Center. DS-56806
- Updated Deep Security Manager to include the option to log Trend Micro Vision One issues (**Administration > System Information > Diagnostic Logging...**). DS-58533
- Updated Deep Security Manager's Default Real-Time Scan Configuration (**Computers > Details > Anti-Malware > General > Real-Time Scan > Malware Scan Configuration**) to enable Behavior Monitoring and Predictive Machine Learning by default. Later versions of Deep Security Agents (Windows agent 20.0.0.1559 and later, and Linux agent 20.0.0-1822 and later) will have Use Custom Actions set to Pass by default, and will log Anti-Malware Events. Earlier versions of agents will have Behavior Monitoring and Predictive Machine disabled if their **Possible Malware** Action to Take is set to Pass. DS-59282
- Updated the Deep Security Manager to make Trend Micro Vision One related settings and features consistent after the onboarding. DS-58788
- Updated the Deep Security Manager to improve Search Computer API and List Computer API performance. DS-56722

Resolved issues

- When the Deep Security Manager installer detected at least 16 GB of RAM on the operating system, it was not automatically allocating 8 GB of RAM to the Java Virtual Machine as is recommended for best performance. SEG-87319/03645194/DS-55701

- The Deep Security Manager was unable to communicate with agents in some environments, causing agent offline issues. SEG-86783/SF03637359/DS-56400
- Anti-Malware Scan scheduled tasks that timed out sometimes restarted instead of triggering a Scheduled Task Skipped event as expected. DS-59252
- The Deep Security Manager console command used to set a preferred IP address for Deep Security Agents with multiple IPs was sometimes not working, causing some agents to be unable to connect. DS-58878
- Deep Security Manager version update install was failing under some configurations. SEG-95357/SF03988405/DS-59222
- Deep Security Manager installed an incorrect version of the relay in some cases. DS-59634
- The Deep Security license check for Trend Micro Vision One registration was sometimes failing. DS-59645
- After changing the settings for a policy (**Policies > Details > Settings > General**), the **Reset all settings to Inherent** button did not work for Automatically Send Policy Changes to Computers or Perform Ongoing Recommendation Scans. DS-56830
- Links were sometimes not clickable in the Computer Status of the **Dashboard** tab, and for Agent/Appliance Upgrade Recommended (New Version Available) alerts opened in the List View of the **Alerts** tab. DS-57968

Security updates

Security updates are included in this release. For more information about how Trend Micro protects against vulnerabilities, visit [Vulnerability Responses](#). Note that in line with responsible disclosure practices, CVE details are only made available for select security updates once patches have been made available for all impacted releases. DS-33781/DS-58415/DS-58917/DS-51741/DS-59636

Highest CVSS: 9.8

Highest severity: Critical

Deep Security Manager - 20.0.262 (20 LTS Update 2020-11-26)

Release date: November 26, 2020

Build number: 20.0.262

New Features

Integrate with Trend Micro Vision One: Trend Micro Vision One applies effective expert analytics and global threat intelligence using data collected across multiple vectors - email, endpoints, servers, cloud workloads, and networks. For more information, see "[Integrate with Trend Micro Vision One \(XDR\)](#)" on page 1901.

Custom actions for Behavior Monitoring and Machine Learning: This release provides the ability to specify custom actions for Behavior Monitoring and Predictive Machine Learning.

Enhancements

- The **Computer Description** field for Smart Folders can be used as a search criteria. SEG-85288/DS-55034
- Added the "[Migrate an agentless solution from NSX-V to NSX-T](#)" on page 1656 Help Center article. DS-51619

Resolved issues

- In the Smart Folder Editor, the computer type was listed as Undefined instead of Physical Computers. DS-32765
- On the vCenter connector properties page, when a user clicked **Remove NSX Manager** and then re-registered the NSX-T manager, the network-related features displayed **Not supported (NSX license limited)**. DS-56411
- An internal server error occurred when AWS was added to a Smart Folders sub-folder with the **Version** condition selected. DS-50785
- When Log Inspection or Intrusion Prevention rules were added, the Web Application Firewall sometimes blocked the page. DS-56448

Security updates

Security updates are included in this release. For more information about how Trend Micro protects against vulnerabilities, visit [Vulnerability Responses](#). Note that in line with responsible disclosure practices, CVE details are only made available for select security updates once patches have been made available for all impacted releases. DS-57603

Highest CVSS: 3.7

Highest severity: Low

Deep Security Manager 20.0.198 (20 LTS Update 2020-10-19)

Release date: October 19, 2020

Build number: 20.0.198

Enhancements

- Enhanced the description of the Activation Failed event to specify why the event occurred. DS-29719

Resolved issues

- If you installed standalone agents on VMware VMs, and then you subsequently added vCenter to Deep Security Manager, you would see duplicate computer records in the manager for one VM. DS-55316
- The settings on **Policies > Settings > Advanced** could not be changed because the **Inherited** option could not be deselected. DS-56309
- The **Administration > Updates > Security** page took a long time to load.

Security updates

Security updates are included in this release. For more information about how Trend Micro protects against vulnerabilities, visit [Vulnerability Responses](#). Note that in line with responsible disclosure practices, CVE details are only made available for select security updates once patches have been made available for all impacted releases. DS-54102/DS-53674

Highest CVSS Score: 6.5

Highest severity: Medium

Deep Security Manager 20.0.174 (20 LTS Update 2020-09-16)

Release date: September 16, 2020

Build number: 20.0.174

New features

Improved management and quality

Agent Version Report: The **Agent Version Report** has been created in order for you to view a summary of how many agents are using a specific agent version, the percentage of total agents each version is using and an overview of how many agents are online and how many are offline, all of which are broken down based on the Deep Security Agent's platform (OS). To generate the report, go to **Events & Reports > Generate Reports > Single Report > New > Agent Version Report**.

Azure Government improvement: Azure Government resources can be added through the Deep Security Manager Azure connector (**Computers > Add > Add Azure Account**). For more information, see [How do I protect Azure Government instances?](#)

Database encryption: The process of encrypting the communication between Deep Security Manager and your database has been simplified. For more information, see "[Encrypt communication between the Deep Security Manager and the database](#)" on page 1582.

Enhancements

- Reduced the time it takes to validate GCP service accounts when changing your GCP Account Properties configuration. Previously, this took a long time when there were a large number of auto-generated GCP projects. SEG-81743/SF03452889/DS-53515
- Updated the pager numbers, phone numbers and mobile numbers listed on the **User Properties** window (click your email at the top of the console and select **User Properties**) so they can be configured to exceed more than 30 digits.
- Updated the My User Summary on the console and the User and Contact Report (**Events & Reports > Generate Reports > Single Report**) to reflect the logins that have occurred in the last 30 days. SEG-81216/03407489/DSSEG-5897
- Added support for VMware Cloud Director (vCloud) 10.1.1 (with NSX-V only).
- Improved the "Scheduled report sending failed" error message by adding a more thorough description. For more information, see [Troubleshoot: Scheduled report sending failed](#). SEG-77886/03221276/DS-54615
- Updated the **New Malware Scan Configuration Properties (Policies > Common Objects > Malware Scans > New)** default settings to match the default settings for the **Default Malware Scan Configuration Properties**.

Resolved issues

- The **Computer Status** widget on Deep Security Manager's dashboard did not display the correct number of managed computers. DS-53294
- The Deep Security Agent trusted certificates were not automatically renewed. SEG-79146/SF03240076/DS-52488
- The AWS Contract License Exceeded alert sometimes occurred even though the number of protected computers did not exceed the limit. SEG-82932/SF03491496/DSSEG-5974
- Imported VMs in vClouds were unable to activate. SEG-75542/03189161/DS-53447
- The console sometimes showed the incorrect Log Inspection status. /DS-54630
- Some Intrusion Prevention rules were designed to operate exclusively in Detect Only mode, however you were able to change their behavior on the policy and computer pages. DS-54667
- An incorrect number of overrides were displayed on **Computer/Policy Editor > Overrides**. SEG-83802/03513073/DS-54710
- There was a rights issue with Scheduled Tasks that caused incorrect behaviors to occur when creating them. SEG-78610/SF03320936/DS-53292
- The MasterAdmin could not create a scheduled task for all computers. DS-55522
- Ransomware Event History on the dashboard displayed incorrect information. DS-55494

Security updates

Security updates are included in this release. For more information about how Trend Micro protects against vulnerabilities, visit [Vulnerability Responses](#). Note that in line with responsible disclosure practices, CVE details are only made available for select security updates once patches have been made available for all impacted releases. DS-52678 /DS-21167 /DS-53059

Highest CVSS Score: 7.0

Highest severity: High

Notices

Red Hat Enterprise Linux 5 and 6 are no longer supported platforms for Deep Security Manager. For a list of supported Deep Security Manager platforms, see "[Deep Security Manager requirements](#)" on page 329.

Deep Security Manager 20 (long-term support release)

Release date: July 30, 2020

Build number: 20.0.60

Action required if you use cross-account roles to add AWS accounts to Deep Security using the API `/rest/cloudaccounts/aws`

To better align with AWS best practices and improve AWS account security, Trend Micro have made a change to the process of adding a new AWS account into Deep Security using cross-account roles. Previously, when using a cross-account role for authentication, Deep Security required two pieces of information: a role ARN, and an external ID trusted by the role. This has now changed to a new process where Deep Security provides the external ID, and requires that the role provided has included this external ID in its IAM trust policy. This change provides stronger security in shared Deep Security environments, and ensures that strong external IDs are always used. For details on the new process of adding cross-account roles using manager-generated external ID, see ["Add an AWS account using a cross-account role" on page 649](#).

Action Required:

Switch your external ID to a manager-generated one: ["Update the external ID" on page 657](#).

If you're using cross-account roles with the API `/rest/cloudaccounts/aws`, see [Action required if you are using cross-account roles with the API `/rest/cloudaccounts/aws`](#).

New features

Updated platform support

- Red Hat Enterprise Linux 8 (64-bit)
- Windows Server 2019 (64-bit)
- Oracle 18 database support
- Oracle 19c database support
- PostgreSQL 11 database support
- SQL Server 2019 database support

Google Cloud Platform: Google Cloud Platform (GCP) has been integrated with Deep Security. You can now view new GCP instances that come online or are removed, and which instances have protection. If you are using multiple clouds on-premise and in your data center, Deep Security can provide visibility for all of your environments. This feature is available for VMs that

have Deep Security Agent 12.0 or later installed. For details, see ["Add a Google Cloud Platform account" on page 677](#).

End of Support for Red Hat Enterprise Linux 6: Red Hat Enterprise Linux 6 is no longer a supported platform for Deep Security Manager. Upgrade your operating system.

Improved Security

Protect VMs in NSX-T environments: Trend Micro has integrated the latest VMware Service Insertion and Guest Introspection technologies which enables you to protect your guest VMs using Intrusion Prevention, Web Reputation, Firewall, Integrity Monitoring and recommendation scans on NSX-T hosts with agentless protection.

Seamless network protection for NSX-T environments: Deep Security Manager now sends guest VMs' network configuration to all Deep Security Virtual Appliances that are under the same cluster. The effect is that the appliances can now maintain the protection of guest machines that use the network features during and after a vMotion migration from one ESXi host to another under the same cluster. This feature only applies to NSX-T environments where the guest machine is using an assigned policy without network features overrides.

Continuous Anti-Malware protection for NSX-T environments: Deep Security Manager now sends guest VMs' Anti-Malware real-time configuration to all Deep Security Virtual Appliances that are under the same cluster. The effect is that the appliances can now maintain the protection of guest machines that use the Anti-Malware real-time feature during and after a vMotion migration from one ESXi host to another under the same cluster. This feature only applies to NSX-T environments.

Agent version control: Agent version control gives you and your security operations team control over the specific versions of the Deep Security Agent that can be used by features like deployment scripts and upgrade on activation. This provides increased control over the Deep Security Agent used in your environment. For more information, see ["Configure agent version control" on page 1442](#).

Improved management and quality

Differentiate between Red Hat and CentOS platforms: Deep Security Manager can distinguish between a Red Hat and CentOS platforms and operations.

Visibility, Protection, and Management on Google Cloud Platform (GCP):

- VMs are organized into projects, which lets you easily see which GCP VMs are protected and which are not.

- Assign policies automatically based on the GCP Instance Labels, GCP Network Tags, and other instance attributes while auto-scaling up.
- Group related GCP instances in Smart Folders based on the GCP instance labels, GCP network tags, and other instance attributes to simplify the management.

Automate Google and AWS accounts via REST API: As you move to more automated deployments, having APIs to perform common tasks becomes a greater requirement. Deep Security provides REST APIs to allow you to automate the adding of both AWS and Google Cloud accounts into Deep Security.

Actionable recommendations for Anti-Malware issues: In order for you to understand what is happening in the Anti-Malware system, many Anti-Malware events have been updated to provide more details on why a cancellation or failure has occurred. These events can occur for manual, quick, or scheduled Anti-Malware scans. The enhanced detail is provided in the events with Deep Security Manager as well as provided through SIEM or AWS SNS.

NSX-T Network Throughput improvement: By introducing the Data Plane Development Kit (DPDK), Trend Micro has made the network throughput three times faster when compared with prior technology, Raw Socket.

Search Cloud Instance Metadata: Added the ability to do a simple search or advanced search for Cloud Instance Metadata on the Computers page. This allows you to easily find workloads with specific labels, network tags, and more.

Instance Metadata Service Version 2 (IMDSv2) support: IMDSv2 is supported in this release. For details, see ["How does Deep Security Agent use the Amazon Instance Metadata Service?" on page 1911](#)

Upgrade on activation: Deep Security Manager now has options (**Administration > System Settings > Agents > Automatically upgrade Linux/Windows agents on activation**) that enable you to automatically upgrade the Deep Security Agent on Linux and Windows computers to the version specified in **Administration > System Settings > Updates > Software > Agent Version Control** when the agent is activated or reactivated. For details, refer to ["Automatically upgrade agents on activation" on page 1462](#).

Enhanced visibility of scheduled scan tasks and event based tasks: Scheduled scan tasks and event-based tasks have been improved by providing scan visibility as well as specific reasons for each uncompleted Anti-Malware scan and recommended actions to resolve the scan.

Reporting improvements to allow chargeback to cloud accounts: The Security Module Usage Report now includes the Cloud Account ID (AWS Account ID, Azure Subscription ID or GCP Project ID) for protected instances.

Multiple vCenters: You can add multiple vCenters in the Deep Security Manager, and associate them to the same NSX-T Data Center. An overwrite warning message is displayed if you are using NSX Data Center for vSphere (NSX-V), which does not support the use of multiple vCenters, or if the NSX-T Manager has been registered with another Deep Security Manager cluster.

Enhancements

UI improvements:

- Added file hash values to Anti-Malware events that are exported to CSV (**Events & Reports > Anti-Malware Export > Export to CSV**). SEG-61890/SF02510024/DS-53441
- Updated the descriptions related to memory on the System Information page so they're more accurate and easier to understand.
- Improved the description of Behavior Monitoring events by including the reason the event occurred.
- Added a **GCP Network Tag** column to the **Computers** tab.
- Added GCP information such as Instance ID, Labels, Network tags, and more, to **Computer Editor > Overview > General**.
- Added the **Cloud Instance Metadata** field to the **Computers** page.
- Added a progress bar to **Administration > User Management > Roles > New > Computer Rights > Selected Computers** to indicate the status of the computers list that's loading.
- If there are a lot of agent events in a single heartbeat, they will be split into multiple "Event Retrieved" events.
- Enhanced the Relay management experience by providing possible solutions for the "Empty Relay Group Assigned" alert in the alert's description and removing the relay count for tenants that are using the Primary Tenant Relay Group.
- Added "Database Type" and "Database Server" columns to **Administration > Tenants**.
- Added the "Kernel Unsupported" system event to indicate if your computer has been upgraded to an unsupported kernel.
- Added a reason ID for the "Manual Malware Scan Cancellation complete" system event. The reason ID is displayed in REST API calls, SNS information and SIEM information.

- Added the "TrendMicroDsPacketData" field to Firewall events that are syslog forwarded via the Deep Security Manager.
- Added the **Validate the signature on the agent installer** checkbox on **Support > Deployment Scripts**. For more information, see "[Check digital signatures on software packages](#)" on page 427.
- Improved the "License Changed" event description by specifying if the plan ID is for Azure Marketplace billing.
- Renamed the **Service Token** setting to **Data Source GUID** on **Administration > System Settings > Managed Detection and Response**.
- Added a "Agent GUID" column to the **Computers** page so you can search computers by the Agent GUID.
- Included a search bar under **Administration > Updates > Software > Local**.
- When creating a smart folder, you can now select "Version" as the filter criteria to filter computers based on their Agent version.
- Added the ability to hide all empty AWS regions, VPCs, subnets, and directories, reducing clutter and increasing load speed on the **Computers** page.
- Aggregated identical agent events in a single heartbeat under a single event.
- Modernized the **Policies > Lists > Port Lists** page.
- When creating a smart folder, you can now select "Task(s)" as the filter criteria, which filters for values displayed in the "Task(s)" column on the Computers page. For example, you could create a smart folder that lists all computers that contain "Scheduled Malware Scan Pending (Offline)" as the task. Additionally, if you are using the Deep Security API to search for computers, you can now search on the value of the tasks/agentTasks and tasks/applianceTasks fields.
- Deep Security Manager now prevents you from importing duplicate Trusted Certificates.
- Redesigned the **Computers > Add Account** synchronization scheduling to handle many more connectors per tenant, reduce idle thread time, and sync connectors with invalid credentials less frequently.
- By default, the "My User Summary" widget on the Dashboard only displays information about sign-ins that have occurred within the last 24 hours.
- You can choose not to send packet data back to the Deep Security Manager by going to **Administration > Agents > Data Privacy** and selecting **No**.
- Deep Security Manager diagnostic packages have the ability to be encrypted. To encrypt your package and logs, go to **Administration > Create Diagnostic Package > Enable AES**

256 encryption and enter a password.

Note: Encrypted zips cannot be extracted using the default ZIP extraction tool available in Windows, it needs to be extracted by 3rd party tools like 7Zip, WinZip etc.

- Redacted potentially sensitive information from the diagnostic packages and logs.

Event-based tasks:

- Improved the capability of event-based tasks by adding support for GCP security automation with account name, labels, network tags and more in the task conditions.
- Introduced "Cloud Vendor" in the event-based tasks conditions in order to limit a task's scope for a specific public vendor (for example, AWS or GCP).

Commands:

- Added the following command:

```
dsm_c -action changesetting -name  
com.trendmicro.ds.antimalware:settings.configuration.maxSelfExtractRT  
ScanSizeMB -value 512
```

When Deep Security Agent could not determine the type of the target file, the scan engine loaded the file to memory to identify if it was a self-extract file. If there were many of these large files, the scan engine consumed lots of memory. Using the command above, the file-size limitation is set to 512MB for loading target files. When the file-size exceeds the set limitation, the scan engine will skip this process and scan the file directly.

To implement this enhancement:

1. Run the command in Deep Security Manager to change the value in the database.
 2. Send the policy to your target Deep Security Agent to deploy the setting.
- Added the ability for the Deep Security Administrator to hide unresolved recommendation scan results from the Intrusion Prevention, Integrity Monitoring and Log Inspection tab in the policy pages. To hide the unresolved recommendation scan results, use the following commands

Intrusion Prevention:

```
dsm_c -action changesetting -name
```

```
com.trendmicro.ds.network:settings.configuration.showUnresolvedRecommendationsInfoInPolicyPage -value false
```

Integrity Monitoring:

```
dsm_c -action changesetting -name  
com.trendmicro.ds.integrity:settings.configuration.showUnresolvedRecommendationsInfoInPolicyPage -value false
```

Log Inspection:

```
dsm_c -action changesetting -name  
com.trendmicro.ds.loginspection:settings.configuration.showUnresolvedRecommendationsInfoInPolicyPage -value false
```

Enhanced scheduled tasks:

- **Task enabled** has been renamed to **Enable task** on the last screen of the Create Scheduled Task wizard
- Synchronize cloud account now indicates it only supports vCloud and Azure connectors
- Computer/group selection details now display in list view for Anti-Malware scans and Intrusion Prevention tasks

Virtual Appliance:

- Added the ability to auto-activate guest VMs protected by the Deep Security Virtual Appliance in an NSX-T environment.
- Added the "VMware NSX Policy Configuration Conflict" system event. This event is generated when Deep Security Manager detects that a NSX-T group is configured with different security policies for Endpoint Protection and Network Introspection (E-W).
- Updated Deep Security Manager to allow vCloud accounts to be added even if the virtual machine hardware information is missing.
- When you upgrade the Deep Security Virtual Appliance SVM in NSX-T Manager, Deep Security Manager will now detect that a new SVM is now protecting guest VMs, and will auto-activate those VMs after the upgrade.
- Upgraded the vCloud Connector in Deep Security Manager supports vCloud 9.7 and vCloud 10.0.
- Added the ability to sync Deep Security Manager policies to NSX-T environments.

- Improved the experience when deleting vCenter Connectors with NSX-T Manager. Previously, you had to manually remove the NSX-T component as a service profile, endpoint rules and service deployments, or the vCenter deletion would fail.
- Deep Security Manager can now connect to NSX-T Data Center using LDAP account credentials. Previously, only local NSX-T account credentials could be used.

Other:

- When Anti-Malware actions fail, the results will be displayed in the Syslog result field.

Resolved issues

- When the **Hide Unlicensed modules** option was selected on **Administration > User Management > Users > customer's current account > Settings**, all of the modules were hidden. SEG-77037/03228448/DS-51202
- When the **Alert on any Computer** action was selected for Intrusion Prevention, Firewall, Integrity Monitoring or Log Inspection rules, the computers were not automatically updated with the new policy. SEG-66986/SF02684105/DSSEG-5201
- Sometimes, you couldn't edit a smart folder. SEG-74078/SF03120830/DSSEG-5450
- When the **Alert on any Computer** action was selected for Intrusion Prevention, Firewall, Integrity Monitoring or Log Inspection rules, the computers were not automatically updated with the new policy. DS-50216/SEG-77260
- Anti-Malware events that were marked as "Pass" were not properly counted on the dashboard or under Anti-Malware events. DS-49364/SEG-70872
- When an agent activated with no AWS metadata but then provided it on a later heartbeat, the cloud provider was not updated, which caused the computer to never be rehomed properly. DS-50713/SEG-77150
- When you did an advanced search on the Computers page for **Status Light > Equals > Managed [Green]**, then selected **Export to CSV**, the CSV file did not contain the listed computers. DS-49936/SEG-74140
- Azure accounts could not be added in Azure Government regions because the login endpoint was changed. This only applies to Azure Marketplace deployments. DS-52399
- After upgrading VMware ESX, you had to manually re-sync the vCenter to see the new platform information. DS-50053
- For tenants, the Security Module Usage Report was only visible if you had access to the default "Full Access" role. (SEG-70494/SF02940195/DS-47492)

- The sign-up page did not render properly in Internet Explorer. (SEG-73072/SF03075345/DS-48944)
- When several emails with large bodies were queued, they were loaded all at once instead of in batches, which caused a large amount of memory to be used. (SEG-71863/SF03024164/DS-49833)
- When the "Untagged" filter was selected on the dashboard, some widgets continued to display tagged items. (SEG-63290/SF02585007/DS-43795)
- Tenants in a multi-tenant setup could move their relays to the primary tenant relay group. This would cause the relays to disappear from their 'Relay Management' page. Tenants are now prevented from moving their relays to the primary tenant relay group. (SEG-57715/02322762/DS-47509)
- Performance issues occurred when there were 1,000s of requests to download the same SVG file because the file wasn't cached. (SEG-64280/DS-45002)
- AIA hosts with the same Virtual UUID fail when "Activate a new Computer with the same name" was selected. (SEG-66346/02725330/DS-45423)
- In some multi-tenant environments, you could not log in as a tenant. For more information, see <https://success.trendmicro.com/solution/000238704>. (SF02873892/SEG-68674/DS-46391)
- When Integrity Monitoring was enabled but Anti-Malware was turned off, a warning message would appear indicating "Security Update: Pattern Update on Agents/Appliance Failed". (SEG-68454/SEG-67859/DS-32205)
- In the **Malware Scan** configurations window, the content of the **Advanced** tab was displayed in the **General** tab. (SEG-64701/SF02657864/DS-44176)
- Deep Security Manager had issues loading the computers trees on some pages when there were a lot of computers and folders. (SEG-58089/SF02345427/DS-44424)
- AWS connectors sometimes failed to synchronize. (SEG-66472/DS-45029)
- The column names in the CSV output of the "Security Module Usage Report" were partially misaligned with the data columns. (SEG-66717/SF02619240/DS-45130)
- In the Malware Scan Configuration window (**Computers/Policies > Anti-Malware > General > Manual Scan > Edit > Advanced** and select **Scan Compressed File**) the **Maximum number of files to extract** setting could not be set to 0, meaning unlimited. (SEG-65997/02685854/DS-45081)
- Deep Security Manager with PostgreSQL sometimes stopped forwarding events to AWS SNS. (SEG-67362/SF02798561/DS-45594)

- When Deep Security Manager was deployed in an environment with a large number of hosts and protection rules, the manager would sometimes load data for all hosts, even if the user only requested data from some of the hosts. (SF02552257/SEG-62563/DS-43188)
- When booting up, Deep Security Manager validates the database schema of the events tables. Logs always said that the schema was updated, even if no update was actually required. (DS-43196)
- Active Directory synchronization sometimes would not finish. (SEG-52485/DS-38203)
- When a custom Anti-Evasion posture was selected in a parent policy (in the policy editor **Settings > Advanced > Network Engine Settings > Anti-Evasion Posture > select 'Custom'**), that setting did not appear in the child policies. (SF02434648/SEG-60410/DS-41597)
- On Linux systems, the default maximum number of the concurrent opened files did not meet Deep Security Manager's needs, resulting in the manager failing to acquire file handles. As a result, features in Deep Security Manager failed randomly and a "Too many open files" message appeared in logs. (SEG-59895/DS-43192)
- The "Activity Overview" widget sometime displayed the incorrect database size. (SF02449882/SEG-63362/DS-43946)
- When sorting the "Alert Configuration" page by the "ON" column, the number of alerts was sometimes incorrect. (SF02578797/SEG-63560/DS-43685)
- Certain smart folder search criteria caused an `IllegalStateException` error. (SF02436019/SEG-60330/DS-41369)
- The memory usage percentage display on the "Manager Node Status" dashboard widget did not match the last recorded system memory usage percentage. (SF02218013/SEG-55761/DS-39149)
- In Deep Security Manager, under **Policies > Intrusion Prevention Rules > Application Types > (select DNS client) > Properties > General**, the Port setting would change to "Any" after any updates to the port list. (SEG-55634/DS-39444)
- Reconnaissance alerts could not be disabled because the option was not available. (SEG-49907/DS-35122)
- Some Azure Virtual Machine types categorized incorrectly. (SF01885266/SEG-48561/DS-33951)
- Users of AWS Marketplace metered-billing would see an error reported in system events when the billing job was processed. (SF1899351/SEG-48580/DS-33955)

- Integrity Monitoring detailed change and recommendation reports was not running against smart folders. (SF2056260/SEG-51781/DS-35886)
- When the Computers page was grouped by status, it sometimes didn't display the correct total number of computers for each group. (SF01655622/SEG-44858/DS-37769)
- When Deep Security Manager was connected to both a case-sensitive Microsoft SQL database and VMware NSX, the Deep Security Manager upgrade readiness check would sometimes fail and block the upgrade. (SF02060051/SEG-52044/DS-38405)
- Scheduled task scans could be initiated by a user for computer groups that they do not have access to in their roles, which caused an error to occur. (SF02119582/SEG-53275/DS-38892)
- Deep Security Agent sometimes went offline when duplicate virtual UUIDs were stored in the database. (SF01722554/SEG-41425/DS-39272)
- False alerts regarding the license expiration were occasionally raised. (SF01484611/SEG-41437/DS-33831)
- Using a local key secret containing the \$ symbol stopped the upgrade or fresh install of Deep Security Manager. (SF02013831/SEG-57243/DS-39526)
- Deep Security used an open source library called SIGAR that is no longer maintained or supported. This can cause applications to crash and other unintended issues in the future. (SF02184158/SEG-54629/DS-39394)
- When an invalid or unresolvable SNMP server name was configured in **Administration > System Settings > Event Forwarding > SNMP**, it caused SIEM & SNS to also fail. (SF02339427/SEG-57996/DS-39865)
- Forwarding events "via Deep Security Manager" with SIEM event forwarding would not work if the Deep Security Manager hostname was not obtained through DNS resolution. (SEG-50655/DS-37374)
- The events exported via AWS SNS did not contain the HostOwnerID, which corresponds to the AWS Account ID. (SF02420860/SEG-59870/DS-41089)
- In the computer or policy editor in Deep Security Manager, under **Anti-Malware > General > Real-Time Scan > Schedule > Edit**, the **Assigned To** tab was sometimes empty, even when the schedule was assigned correctly to computers and policies. (SF02374723/SEG-58761/DS-41036)

Security updates

Security updates are included in this release. For more information about how Trend Micro protects against vulnerabilities, visit [Vulnerability Responses](#). (DS-45446/DS-44955/DS-

43627/DS-28754/DS-32322/DS-33833/DS-26068)

Highest CVSS score: 9.8

Highest Severity: Critical

- Updated the JRE to the latest Java Update (8.0.241/8.43.0.6).
- Updated third-party libraries used by Deep Security Manager. (DS-24214)
- Upgraded Apache Tomcat to 8.5.53. (VRTS-4652)

Known issues

- If you are using an Oracle database, this upgrade will take longer than usual due to a database schema change. For more information about Deep Security Manager upgrades, see [Upgrade Deep Security Manager](#).
- When a new Deep Security Virtual Appliance is deployed, the VM name is displayed as "Trend Micro_Custom - <version>", if you're using a local web server to store the Deep Security Virtual Appliance software package. This has no effect on the integrity of the appliance.
- Due to issues discovered during internal testing with SQL 2008, Trend Micro now blocks upgrades to Deep Security feature release when SQL 2008 is the Deep Security Manager database. Microsoft SQL Server 2008 is no longer supported by Microsoft and therefore is no longer being tested and supported for use as a database for the latest releases of Deep Security Manager. For more information from Microsoft, see [End of support for SQL Server 2008 and SQL Server 2008 R2](#). For the full list of databases supported for use with Deep Security Manager, see "[Deep Security Manager requirements](#)" on page 329 system requirements. (DS-36715)
- The automatic removal of a vCenter account from Deep Security will fail if NSX-T is configured to have the same service chain bound to Deep Security and third-party services simultaneously. This problem occurs because the NSX-T API doesn't allow Deep Security to modify the service chain with its associated service profiles. To work around this issue, remove vCenter manually. For details, see "[Uninstall Deep Security from your NSX environment](#)" on page 1679. DS-47944
- Deep Security Manager no longer supports NSX-T Manager version 2.x. Upgrade your NSX-T Manager to version 3.0.0 or later. DS-50387

What's new in Deep Security Agent?

Linux

Deep Security Agent - 20.0.1-7380 (20 LTS Update 2024-04-24)

Release date: April 24, 2024

Build number: 20.0.1-7380

New features

User mode solution: This feature provides basic Activity Monitoring and Anti-Malware functions through Fanotify and eBPF on systems that lack kernel support. Deep Security Agent cannot protect runtime container workloads in this mode.

Enhancements

- Deep Security Agent 20.0.1-7380 and later supports most features for SUSE Linux Enterprise Server 12 SP5 (PowerPC little-endian). Application Control, Integrity Monitoring, and Trend Vision One (XDR) are currently unsupported for this platform. DSA-2626
- Deep Security Agent 20.0.1-7380 and later supports most features for SUSE Linux Enterprise Server 15 SP2, SP3, and SP4 (PowerPC little-endian). Application Control, Integrity Monitoring, and Trend Vision One (XDR) are currently unsupported for this platform. DSA-2630
- Deep Security Agent now supports Trend Vision One Service Gateway exclusions. This is only supported for Trend Cloud One - Endpoint & Workload Security users at this time. V1E-17754
- Deep Security Agent can have its proxy configuration set by the Trend Vision One Proxy Manager. V1E-14557

Resolved issues

- Deep Security Agents running in cloud environments sometimes could not be activated for Trend Cloud One - Endpoint & Workload Security. DSA-4861

- When SAP Scanner was enabled, system events for "SAP: Anti-Malware module is not ready" or "SAP: Virus Scan service is not working correctly" sometimes displayed during Deep Security Agent upgrade. These system event messages were triggered by the restart of Deep Security Agent modules. There was no functional impact. DSA-4603
- Deep Security Agent caused high CPU usage on some systems using TLS inspection with the `tm_netagent` process running. PCT-22031/DSA-4805
- After enabling Trend Micro Service Gateway Generic Caching Service (GCS) from Trend Vision One, Deep Security Manager and Trend Cloud One - Endpoint & Workload Security displayed the "Check Status Failed" error when communicating with Deep Security Agent. DSA-4763
- The local Smart Protection Server sometimes showed an incorrect number of Deep Security Agents. DSA-3780

Deep Security Agent - 20.0.1-4540 (20 LTS Update 2024-03-20)

Release date: March 20, 2024

Build number: 20.0.1-4540

New features

CPU Usage Control: This feature provides 3 predefined modes to throttle CPU usage of Anti-Malware Real-Time Scan and Activity Monitoring (**Computer > Settings > General > CPU Usage Control**). This is only supported for Trend Cloud One - Endpoint & Workload Security customers at this time. DSA-2465

Enhancements

- SAP Scanner is now supported on Deep Security Agent 20.0.1-4540 or later for Red Hat Enterprise Linux 9. DSA-4213
- The SAP Scanner status for Deep Security Agent is now displayed in the console. DSA-3329
- The Deep Security Agent version is now displayed in the SAP Scanner library. SF07483850/PCT-10077/DSA-3304

Resolved issues

- Some systems encountered higher than normal CPU usage and performance issues if Deep Security Agent lost its connection to the Smart Protection Server. SF07552865/PCT-12430/DSA-3784
- Deep Security Agent incorrectly classified the MIME type of .dwg files generated by AutoCAD, from AutoCAD 2004 to AutoCAD 2024. SF07027236/SEG-186079/PCT-5797/DSA-2901

Known issues

- When SAP Scanner is enabled, system events may cause a message "SAP: Anti-Malware module is not ready" or "SAP: Virus Scan service is not working correctly" to be displayed temporary during the Deep Security Agent upgrade. This is caused by the restart of Deep Security Agent modules. There is no functional impact. DSA-4572
- After enabling Trend Micro Service Gateway Generic Caching Service (GCS) from Trend Vision One, Deep Security Manager and Trend Cloud One - Endpoint & Workload Security display "Check Status Failed" error when communicating with Deep Security Agent. For details, see [Deep Security Agent reports "Check Status Failed" after enabling Service Gateway Generic Caching Service](#). DSA-2756

Deep Security Agent - 20.0.1-3180 (20 LTS Update 2024-02-29)

Release date: February 29, 2024

Build number: 20.0.1-3180

Enhancements

- Deep Security Scanner (SAP) now reports files containing Microsoft Office Macros as Active Content, while previously they were identified as Malware. PCT-5979/DSA-3911

Resolved issues

- Migration of agents from on-premise Deep Security Manager to Trend Cloud One - Endpoint & Workload Security using Trend Vision One Service Gateway failed.

This issue could also occur when migrating using other proxy services. PCT-16649/DSA-4144

- The expected MIME type for `.msg` files by the Deep Security Agent SAP Scanner was incorrect. PCT-5797/DSA-4050
- Enabling Intrusion Prevention or Web Reputation Service in Deep Security Agent sometimes resulted in a TLS inspection process (tm_netagent) error log rotation issue. DSA-3965
- Deep Security Agent could not start because a keyword in its system configuration was incorrectly interpreted. SEG-156447/PCT-8768/DSA-3897
- Smart Scan hung during its update because the IPv6 configuration could not be detected automatically. DSA-3287
- When Deep Security Agent is installed on a system with Fanotify enabled, the Anti-Malware process restarting or stopping sometimes caused the system to freeze. PCT-6047/SEG-190061/DSA-4474

Security updates

Security updates are included in this release. For more information about how Trend Micro protects against vulnerabilities, visit [Vulnerability Response](#). Note that in line with responsible disclosure practices, CVE details will only be made available for select security updates once patches have been made available for all impacted releases. VRTS-11708/DSA-3702

Highest CVSS score: 7.8

Highest severity: High

Known issues

- The Application Control Trust Entities block by target trust rule sometimes does not work properly when running a copy of an executable file. PCT-11105/DSA-3324

Deep Security Agent - 20.0.1-690 (20 LTS Update 2024-01-17)

Release date: January 17, 2024

Build number: 20.0.1-690

New features

Command line scan: Deep Security Agent now supports on-demand scans triggered using `dsa_scan` from a command line interface.

This is currently only available to Trend Cloud One - Endpoint & Workload Security customers. For more information, see [Command-line basics](#). V1E-6993

Enhancements

- From 2024 onward, Deep Security Agent versioning is being revised from 20.0.0 to 20.0.1. This requires Deep Security Manager 20.0.883 or later. DSA-3584.

For details, see [Preparedness of DSM/DSA for Supporting 20.0.1 Linux Kernel Support Package \(KSP\)](#).

Resolved issues

- Deep Security Agent was sometimes unable to connect to the local Smart Protection Server. DSA-3564
- When FIPS mode was disabled, Deep Security Agent used the OpenSSL configuration specified by the system environment variables rather than the config specified by the agent. PCT-4914/DSA-2651/DSA-2737/DSA-2738
- Deep Security Agent would incorrectly log network errors when the SAP scanner was enabled. DSA-3548
- Files added to the SAP Scanner allow list without including a file extension were being blocked when they should have been allowed. SF06565062/SEG-170933/DS-77132/DSA-3424
- When using Deep Security Agent on a system with Fanotify enabled, quarantining a file sometimes caused the system to freeze. PCT-6047/SEG-190061/DSA-2473

Known issues

- Updating to Deep Security Agent 20.0.1-690 from some 20.0.0 versions sometimes fails when using Deep Security Relay on Trend Cloud One - Endpoint & Workload Security. For details, see [Failed remote upgrade of self-deployed Workload Security relay from 20.0.0-3445 or later to version revision 20.0.1](#) DSA-

3317

- With the release of Deep Security Agent 20.0.1-690, Trend Micro is changing the version number of the Kernel Support Package (KSP) from 20.0.0 to 20.0.1. This may cause issues downloading the latest kernel driver on some agent versions. To maintain kernel support after the KSP revision, it is suggested that users upgrade to Deep Security Agent 20.0.0-8453 or later. For details, see [Kernel driver download issues with Deep Security Agent \(DSA\) Linux](#). DSA-3588
- Enabling Intrusion Prevention or Web Reputation Service in Deep Security Agent might result in a TLS inspection process (`tm_netagent`) error log rotation issue. For details, see [TLS inspection process error log rotation problem in Deep Security](#). DSA-3773

Deep Security Agent - 20.0.0-8453 (20 LTS Update 2024-01-17)

Release date: January 17, 2024

Build number: 20.0.0-8453

Resolved issues

- Upgrading to Deep Security Agent 20.0.0-7943, 20.0.0-8137, 20.0.0-8268, or 20.0.0-8438 sometimes failed when Firewall, Web Reputation Service, or Intrusion Prevention System were enabled.

This issue is resolved for Trend Cloud One - Endpoint & Workload Security, but continues to affect Deep Security Manager 20.0.854, 20.0.864, and 20.0.879. For details, see [Failure to install or upgrade to Deep Security Agent version 20.0.0-7943 to 20.0.0-8438 for Linux when Network Modules are enabled](#). DSA-3834

Enhancements

- Updated Deep Security Agent to support 20.0.1 Kernel Support Packages. In order to continue Linux Kernel support in 2024, upgrade to Deep Security Agent to 20.0.0-8453+. For details, see [Platform support updates for Deep Security Agent \(DSA\) version revision in January 2024 Update Release](#). DSA-1217

Known issues

- Deep Security Agent is sometimes unable to connect to the local Smart Protection Server. This issue is fixed in 20.0.1-690. For details, see [Deep Security Agent \(DSA\) connection issues with Smart Protection Server \(SPS\) when using proxy](#). DSA-3564

Deep Security Agent - 20.0.0-8438 (20 LTS Update 2023-12-12)

Release date: December 12, 2023

Build number: 20.0.0-8438

New features

Debian 12 support: Deep Security Agent 20.0.0-8438 or later supports Debian 12 including Secure Boot support. This requires Deep Security Manager 20.0.864 or later. DSA-1408

Enhancements

- Remove some file types from the scanning list to avoid high CPU and disk consumption. SF07099651/SEG-188688/DSA-2010
- Agent self-protection now protects the Advanced TLS Traffic Inspection process (tm_netagent) preventing local users with administrator privileges from stopping it. DSA-1042/DSA-1043
- Add the ability to configure target CPU usage of Activity Monitoring. Choose between unlimited, low, and extremely low in the **Trend Cloud One - Endpoint & Workload Security** console. V1E-6246
- Telemetry now reports the IPv4 and IPv6 address of all network interfaces. V1E-4543

Resolved issues

- When using a local Smart Protection Server and a configured proxy, Web Reputation Service would sometimes improperly send traffic through the proxy. Web Reputation Service now sends queries to the local Smart Protection Server directly. DSA-2981

- A memory leak would occur when loading large Suspicious Object lists.
SF06904914/SEG-182231/DSA-1370

Security updates

Security updates are included in this release. For more information about how Trend Micro protects against vulnerabilities, visit [Vulnerability Response](#). Note that in line with responsible disclosure practices, CVE details will only be made available for select security updates once patches have been made available for all impacted releases.
DSA-2722

Highest CVSS score: 9.8

Highest severity: Critical

Known issues

- Enabling Intrusion Prevention or Web Reputation Service in Deep Security Agent might result in a TLS inspection process (`tm_netagent`) error log rotation issue. For details, see [TLS inspection process error log rotation problem in Deep Security](#). DSA-3773
- Upgrading to Deep Security Agent 20.0.0-8438 sometimes fails when Firewall, Web Reputation Service, or Intrusion Prevention System are enabled.

This issue is resolved in Deep Security Agent 20.0.0-8453 or later for Trend Cloud One - Endpoint & Workload Security, but continues to affect Deep Security Manager 20.0.854, 20.0.864, and 20.0.879. For details, see [Failure to install or upgrade to Deep Security Agent version 20.0.0-7943 to 20.0.0-8438 for Linux when Network Modules are enabled](#). DSA-3834

- Deep Security Agent is sometimes unable to connect to the local Smart Protection Server. This issue is fixed in 20.0.1-690. For details, see [Deep Security Agent \(DSA\) connection issues with Smart Protection Server \(SPS\) when using proxy](#)
DSA-3564

Deep Security Agent - 20.0.0-8268 (20 LTS Update 2023-11-21)

Release date: November 21, 2023

Build number: 20.0.0-8268

New Features

- Deep Security Agent now supports Trend Micro Service Gateway Generic Caching Service (GCS). DSA-2035
- Deep Security Agent now supports FIPS mode for Debian 10 and Debian 11. This requires Deep Security Manager 20.0.854 or later. DSA-1955

Resolved issues

- Deep Security Anti-Malware sometimes did not function as expected after the system had resumed from sleep mode (S0 low-power idle mode of the working state, also known as modern standby). SF07326571/PCT-5476/DSA-2485
- Deep Security Manager displayed the status of the VM protected by the Deep Security Virtual Appliance as Offline, after the Deep Security Virtual Appliance had been upgraded to version 20.0.0-7943 or 20.0.0-8137. The Deep Security Virtual Appliance itself was functioning properly and displayed the status as Managed (Online). SF07317008/SF07313849/SF07331882/PCT-4330/PCT-4607/PCT-4899/DSA-2259
- Deep Security Agent incorrectly classified MIME type of `.xml` files generated by Microsoft Word, Excel, PowerPoint, as well as `.dwg` files generated by AutoCAD and R2000. SF07027236/SEG-186079/DSA-2202

Known issues

- Linux virtual machines froze when trying to update the Smart Scan pattern. As a workaround, you can add the `/opt/ds_agent/lib/libvmpd_scanctrl.so=icrc_try_update=0` key to the `ds_am.ini` file and restart the DSA service. SF07031242/PCT-5795/DSA-2616
- Enabling Intrusion Prevention or Web Reputation Service in Deep Security Agent might result in a TLS inspection process (`tm_netagent`) error log rotation issue. For details, see [TLS inspection process error log rotation problem in Deep Security](#). DSA-3773
- Upgrading to Deep Security Agent 20.0.0-8268 sometimes fails when Firewall, Web Reputation Service, or Intrusion Prevention System are enabled.

This issue is resolved in Deep Security Agent 20.0.0-8453 or later for Trend Cloud

One - Endpoint & Workload Security, but continues to affect Deep Security Manager 20.0.854, 20.0.864, and 20.0.879. For details, see [Failure to install or upgrade to Deep Security Agent version 20.0.0-7943 to 20.0.0-8438 for Linux when Network Modules are enabled](#). DSA-3834

Deep Security Agent - 20.0.0-8137 (20 LTS Update 2023-10-26)

Release date: October 26, 2023

Build number: 20.0.0-8137

New features

Miracle Linux 9 support: Deep Security Agent 20.0.0-8137 or later supports Miracle Linux 9, including FIPS mode and Secure Boot support. This requires Deep Security Manager 20.0.844 or later.

Known issues

- Upgrading to Deep Security Agent 20.0.0-8137 sometimes fails when Firewall, Web Reputation Service, or Intrusion Prevention System are enabled.

This issue is resolved in Deep Security Agent 20.0.0-8453 or later for Trend Cloud One - Endpoint & Workload Security, but continues to affect Deep Security Manager 20.0.854, 20.0.864, and 20.0.879. For details, see [Failure to install or upgrade to Deep Security Agent version 20.0.0-7943 to 20.0.0-8438 for Linux when Network Modules are enabled](#). DSA-3834

- Deep Security Manager displays the status of guest VMs protected by the Deep Security Virtual Appliance 20.0.0-7943 as Offline or Check Status Failed (Activation Required). SF07317008/SF07313849/SF07331882/PCT-4330/PCT-4607/PCT-4899/DSA-2259

Deep Security Agent - 20.0.0-7943 (20 LTS Update 2023-09-26)

Release date: September 26, 2023

Build number: 20.0.0-7943

New features

Red Hat Enterprise Linux 8.6 (PowerPC little-endian) on-demand scan support: Deep Security Agent 20.0.0-7943 or later supports only the Anti-Malware on-demand scan feature for Red Hat Enterprise Linux 8.6 (PowerPC little-endian). This requires Deep Security Manager 20.0.817 or later. Security updates are currently unsupported for this platform.

SUSE Linux Enterprise Server 12 (PowerPC little-endian) on-demand scan support: Deep Security Agent 20.0.0-7943 or later supports only the Anti-Malware on-demand scan feature for SUSE Linux Enterprise Server 12 (PowerPC little-endian). This requires Deep Security Manager 20.0.817 or later. Security updates are currently unsupported for this platform.

SUSE Linux Enterprise Server 15 (PowerPC little-endian) on-demand scan support: Deep Security Agent 20.0.0-7943 or later supports only the Anti-Malware on-demand scan feature for SUSE Linux Enterprise Server 15 (PowerPC little-endian). This requires Deep Security Manager 20.0.817 or later. Security updates are currently unsupported for this platform.

Note:

Security updates are not supported on PowerPC platforms at this time. The Advanced Threat Scan Engine (ATSE) status does not display correctly and the following alerts are expected on RHEL 8.6, SUSE 12, and SUSE 15:

- Security Update: Security Update Check and Download Failed (Agent/Appliance error)
- Status: Out of Date

Enhancements

- New commands exist to get proxy information from the command line:

```
dsa_query -c GetProxyInfo  
dsa_query -c GetProxyInfo details=true
```

DSA-864
- All Trend Micro public keys that are used to validate kernel module signatures are now included by default in the Deep Security Agent packages. SF06915385/SEG-185980/DSA-1569

- In order to display agent pattern updates properly, Deep Security Agent 20.0.0-7943 or later requires Deep Security Manager 20.0.759 or later. For more information, see [Incompatible Agent / Appliance Version error in Deep Security Agent 20.0.0-7943](#). SEG-190866/SEG-191017/DSA-1531

Resolved issues

- When Activity Monitoring was enabled, some systems encountered a memory leak. DS-78200
- Deep Security Agent ignored the file if the exclusion list for the file or folder contained an empty path from Deep Security Manager. PCT-1066/DSA-1873

Known issues

- Enabling Intrusion Prevention or Web Reputation Service in Deep Security Agent might result in a TLS inspection process (`tm_netagent`) error log rotation issue. For details, see [TLS inspection process error log rotation problem in Deep Security](#). DSA-3773
- Upgrading to Deep Security Agent 20.0.0-7943 sometimes fails when Firewall, Web Reputation Service, or Intrusion Prevention System are enabled.

This issue is resolved in Deep Security Agent 20.0.0-8453 or later for Trend Cloud One - Endpoint & Workload Security, but continues to affect Deep Security Manager 20.0.854, 20.0.864, and 20.0.879. DSA-3834

- Deep Security Manager displays the status of guest VMs protected by the Deep Security Virtual Appliance 20.0.0-7943 as Offline or Check Status Failed (Activation Required). SF07317008/SF07313849/SF07331882/PCT-4330/PCT-4607/PCT-4899/DSA-2259

Deep Security Agent - 20.0.0-7719 (20 LTS Update 2023-08-29)

Release date: August 29, 2023

Build number: 20.0.0-7719

New features

Miracle Linux 8 support: Deep Security Agent 20.0.0-7719 or later now supports Miracle Linux 8, including FIPS mode. This requires Deep Security Manager 20.0.817 or later.

Enhancements

- Deep Security Agent no longer updates the Smart Scan agent pattern when Smart Scan is disabled, saving network bandwidth. SEG-186625/DSA-1063
- Deep Security Agent now downloads fewer incremental pattern updates, saving network bandwidth. (Agents configured as a Deep Security Relay still download all pattern updates.) DSA-1000
- The "blocking page" Web Reputation Service redirects users to when they try to access a blocked URL can now be viewed in Czech or Polish. DSA-444
- Advanced Threat Scan Engine version has been updated to 22.6. DSA-453

Resolved issues

- Stopping the Deep Security Agent service (`ds_agent`) took longer than usual on some systems. SEG-187365/DSA-1212
- Deep Security Agent sometimes performed security updates even if none were scheduled. SEG-187449/DSA-1064
- Deep Security Agent caused high CPU usage on some systems. SEG-185563/DSA-756
- TLS Inspection Package updates sometimes caused the `ds_nuagent` service to stop unexpectedly. DSA-1319

Deep Security Agent - 20.0.0-7476 (20 LTS Update 2023-07-25)

Release date: July 25, 2023

Build number: 20.0.0-7476

Enhancements

- Updated the dsa-connect service to improve CPU performance. C1WS-12970
- Deep Security Agent 20.0.0-7476 now supports FIPS mode for Red Hat Enterprise Linux 9. DS-77642
- Updated Deep Security Agent Scanner (SAP) to accept up to 512 parallel client connections established by SAP NetWeaver. Note that the previous connection limit was 256. SF06983349/SEG-184190/DS-78229

Resolved issues

- Smart Protection Servers would sometimes lose connectivity with Web Reputation Service. SF06423462/SEG-166651/DSSEG-7858

Deep Security Agent - 20.0.0-7303 (20 LTS Update 2023-06-28)

Release date: June 28, 2023

Build number: 20.0.0-7303

New features

Amazon Linux 2023 support: Deep Security Agent 20.0.0-7303 or later now supports Amazon Linux 2023, including FIPS mode. This requires Deep Security Manager 20.0.789 or later.

Note: At time of release, Amazon Linux 2023 [is not yet certified for FIPS](#). See the [Amazon Linux 2023 release notes](#) for the latest support information.

Amazon Linux 2023 (AWS ARM-Based Graviton 2): Deep Security Agent 20.0.0-7303 or later now supports Amazon Linux 2023 on AWS Graviton 2. This requires Deep Security Manager 20.0.789 or later.

Advanced TLS Traffic Inspection now supports Oracle Linux 9 (64-bit), Red Hat Enterprise Linux 9 (64-bit), and Ubuntu 22.04 (64-bit).

Enhancements

- Deep Security Agent now supports IPv6 addresses using either CIDR or double colon notation, such as fe80:0:0:0:0:0:1/24 or fe80::01. SF04849178/SEG-122076/DS-67280
- Activity Monitoring events now display the FQDN instead of the hostname. SF06709374/SEG-179186/C1WS-14644
- Web Reputation Service now automatically monitor the ports used by the [OS proxy](#) configuration. DS-77233
- Removed unnecessary proxy scheduled tasks from the Deep Security Virtual Appliance. This should prevent `Timed out waiting for relay to msg and Error creating task...` errors in the logs. SF06844880/SEG-179554/DS-77440

Resolved issues

- When Secure Boot is enabled but the signing key has not been loaded, the system would crash when Anti-Malware used the fanotify facility. SF06464888/SEG-167771/DS-76161
- Intrusion Prevention (IPS) might not read the correct payload value, which can result in rule malfunctions. DS-74647
- The Deep Security Agent would report "dsa-connect has not provided status" on every heartbeat, even when Endpoint Sensor was not in use. C1WS-14696
- Deep Security Relay 20.0.0-7119 failed to provide security and software updates when using the [improved Relay](#). SF06935222/SEG-183184/DS-78201
- The Deep Security Agent connection count could overflow under certain conditions. DS-76902
- Some MQTT messages would be sent repeatedly and cause dsa-connect to get stuck in a shutdown loop. DS-76709

Deep Security Agent - 20.0.0-7119 (20 LTS Update 2023-05-29)

Release date: May 29, 2023

Build number: 20.0.0-7119

Enhancements

- MQTT connection credentials were entered in the Deep Security Agent log file (`ds_agent.log`) in certain scenarios. SEG-174560/C1WS-13282
- Updated Deep Security Agent to reduce the amount of redundant data sent when Activity Monitoring is enabled. DS-77657
- Deep Security Agent crashed some systems when they were out of memory. SF06704797/SEG-175243/DSSEG-7875
- Agent self-protection now secures the Advanced TLS inspection process (`ds_nuagent`), preventing local users with administrator privileges from stopping it. DS-74080

Systems running Red Hat Enterprise Linux 7 (64-bit) with SELinux may require some manual configuration to avoid permission issues following this update. For details, see

https://success.trendmicro.com/dcx/s/solution/000293160?language=en_US.

- Deep Security Agent now runs within a predefined group and accept outbound traffic. DS-77415

Resolved issues

- Deep Security Agent only reported a single Anti-Malware event for an infected compressed file, even if it contained multiple infected files. DS-76339
- After replacing a connection, Deep Security Agent reported metrics as though it was still connected to the old connection for up to 4 minutes. DS-77453
- When Anti-Malware was enabled, Deep Security Agent caused high CPU usage on some systems. DS-77758

Deep Security Agent - 20.0.0-6912 (20 LTS Update 2023-05-02)

Release date: May 02, 2023

Build number: 20.0.0-6912

New features

Red Hat Enterprise Linux Workstation 7 support: Deep Security Agent 20.0.0-6912 or later now supports Red Hat Enterprise Linux Workstation 7, including Secure Boot support. This requires Deep Security Manager 20.0.759 or later.

AlmaLinux 9 support: Deep Security Agent 20.0.0-6912 or later now supports AlmaLinux 9, including Secure Boot support. This requires Deep Security Manager 20.0.759 or later.

Enhancements

- Updated Deep Security Agent to make the connection timeout for proxy probing configurable by adding a line to `ds_agent.ini`. SF06664116/SEG-173848/DS-77182

Example proxy probing line in `ds_agent.ini` config file:

```
dsa.proxymanager.ProbeTimeoutInSec=120
```

- Deep Security Agent installer now prevents the agent from updating if it detects SHA-1 was used to sign the certificate on the agent installer. This prevents the agent from updating and becoming unresponsive, since Deep Security Agent 20.0.0-6313 and higher requires RSA-2048 and SHA-256. For more information on certificate upgrade, see [Upgrade the Deep Security cryptographic algorithm](#). DS-76499
- Updated Deep Security Agent to improve MQTT connection quality and reduce the occurrence of connection timeouts. DS-76840
- Deep Security Agent now includes path and PID (process ID) for Anti-Malware events. SF05682761/SEG-147452/DS-72909

Resolved issues

- When connecting through a proxy with FIPS mode enabled, Deep Security Agent sometimes had connectivity issues with IoT devices. SEG-174776/DS-77197
- Deep Security Agent's Anti-Malware module sometimes failed to restart following an IPC (inter-process communication) timeout. DS-76889/SEG-169218
- A compatibility issue between the Deep Security Agent network driver and some third-party products caused systems to crash. SEG-156743/DS-75377

- Deep Security Virtual Appliance sometimes crashed when connecting by HTTPS to a Smart Protection Server. SEG-169451/DS-76968
- Deep Security Agent sometimes reported the network driver status incorrectly after the driver had restarted. C1WS-12896
- When Web Reputation Service was enabled, Deep Security Agent caused some systems to shutdown unexpectedly. SF06680505/SEG-174730/DSSEG-7866
- Files added to the SAP Scanner allow list without including a file extension were being blocked when they should have been allowed. SF06565062/SEG-170933/DS-77132
- Deep Security Agent sometimes crashed when shutting down after downloading new plugins from the relay. DS-76961
- Deep Security Agent caused some systems to reboot unexpectedly. SF06584000/SEG-171147/DSSEG-7851

Deep Security Agent - 20.0.0-6658 (20 LTS Update 2023-03-22)

Release date: March 22, 2023

Build number: 20.0.0-6658

New features

Oracle Linux 9 support: Deep Security Agent 20.0.0-6658 or later with Deep Security Manager 20.0.737 or later now supports Oracle Linux 9, including FIPS mode and Secure Boot support.

Service Gateway: Deep Security Agent 20.0.0-6658 or later with Deep Security Manager 20.0.741 or later now supports the Service Gateway feature, providing forward proxy functionality.

Enhancements

- When an Application Control Trust Entities path rule uses a wildcard without specifying a filename, the wildcard now applies to all files in any directory matching the rule's path. Note that previously, the globstar (**) wildcard would apply to a path rule's directory and subdirectories, as opposed to the single star (*) wildcard which would only match within the path rule's directory. DS-75133

- Web Reputation Service now includes OS platform metadata. DS-75453
- Anti-Malware events generated by the SAP Scanner now include file hashes. DS-75648/SEG-165491
- Application Control now checks web browser execution of .HTML, .HTM, and .JS files. DS-75102
- Deep Security Agent now sends full command lines for processes to Deep Security Manager, improving the Recommendation Scan's rule recommendations. Note that previously, the agent only sent the first 2048 characters of each process's command line. C1WS-11728
- Deep Security Agent 20.0.0-6658 or later with Deep Security Manager 20.0.737 or later now supports Secure Boot for Ubuntu 22.04. DS-73729
- Deep Security Agent 20.0.0-6658 or later now supports the Proxy Manager for Trend Micro Vision One (XDR) Threat Intelligence - User-Defined Suspicious Object (UDSO). DS-75365
- Updated Deep Security Agent's logging system to provide additional information and tracing to debug customer issues more efficiently. The agent now generates five (5) log files (`dsa-connect-X.log`) that are 2MB each instead of the agent's previous three 1MB log files. C1WS-9598

The logger supports an on-demand JSON config file (either `dsa-connect.ini` or `dsa-connect.conf`) with the following configurable options:

- Debug: Enable the debug log messages. The default value is false.
- Count: Number of log files to generate. The default value is 5.
- Size: Maximum size of each log file in bytes. The default value is 2097152.

Example config file:

```
{
  "Debug": true,
  "Count": 5,
  "Size": 2097152
}
```

Resolved issues

- When the Advanced TLS Traffic Inspection "Inspect TLS/SSL traffic" option was set to "No" from the console (**Computer or Policy > Intrusion Prevention > General > Advanced TLS Traffic Inspection**), driver-side SSL packets were sometimes still being processed. DS-76160
 - The Deep Security Agent kernel support package download was sometimes interrupted, generating "Agent Integrity Check Failed" warnings and "Kernel Unsupported" errors. SEG-169497/DS-76545
 - Deep Security Agent's Intrusion Prevention System sometimes failed to block "TCP Congestion Flags" properly. DS-76182
 - Anti-Malware Behavior Monitoring had a driver issue causing kernel warnings on some systems. SF06254724/SEG-163042/ORCA-762
 - When Anti-Malware Smart Scan was enabled, an IPC connectivity issue caused some systems to crash. SEG-169132/C1WS-10821
 - Deep Security Agent security updates were failing due to a file handle issue that prevented files from being removed during an update. DS-75907
 - A process thread timeout caused the Anti-Malware Engine to restart unexpectedly on some systems. SF06524736/SEG-169218/DS-76656
 - When a SOCKS proxy was used, Deep Security Agent failed to provide a Web Reputation Services rating for HTTP URLs. DS-73482/DS-73364
 - Deep Security Agent upgrade sometimes failed because of a missing signature in the agent package. SF06045259/SEG-154576/DS-73668
 - Deep Security Agent was incorrectly generating system events showing that the Advanced Threat Search Engine (ATSE) component had been removed on some systems. SEG-147779/DS-75463
 - Updated Deep Security Agent to increase the MQTT timeout from 30 minutes to 2 hours to help resolve connection issues on some systems. C1WS-11835
 - Deep Security Agent was unable to connect to the Anti-Malware Smart Scan service on some systems. SEG-168468/DS-76433
 - Deep Security Agent caused performance issues on systems generating a large number of container environment Application Control events. SF06538377/SEG-169605/DS-76594
-

Deep Security Agent - 20.0.0-6313 (20 LTS Update 2023-01-31)

Release date: January 31, 2023

Build number: 20.0.0-6313

New feature

Agent self-protection: This feature helps prevent users on the local system from tampering with the agent. For more information, and help configuring agent self-protection, see [Enable or disable agent self-protection in Linux](#).

Rocky Linux 9 support: Deep Security Agent 20.0.0-6313 or later with Deep Security Manager 20.0.716 or later now supports Rocky Linux 9, including FIPS mode and Secure Boot support. DS-73727

Enhancements

- Deep Security no longer supports certificates signed with the SHA-1 algorithm. The agent now requires SSL/TLS certificates issued using SHA-256 to communicate with the Deep Security Manager. C1WS-5676

Warning: To prevent communication errors between the Deep Security Agent and Deep Security Manager, follow the instructions to [Upgrade the Deep Security cryptographic algorithm](#).

If you updated to Deep Security Agent 20.0.0-6313 or later before upgrading the cryptographic algorithms, follow the steps in [Deep Security Agent \(DSA\) offline when OpenSSL 3 rejects certificate with SHA-1 algorithm](#).

- With Anti-Malware and Behavior Monitoring enabled, Deep Security Agent 20.0.0-6313 or later with Deep Security Manager 20.0.716 or later now monitors for suspicious behavior to improve protection against MITRE attack scenarios. DS-73644
- Deep Security Agent 20.0.0-6313 or later with Deep Security Manager 20.0.711 or later now supports FIPS mode for Oracle Linux 8. DS-73778

Resolved issues

- When Application Control was enabled, Deep Security Agent's status sometimes became stuck at "Application Control Ruleset Update In Progress". DS-74627
 - For component updates, Deep Security Agent would attempt with and without use of a proxy and generate an event for each attempt. To make event reporting more straightforward, this behavior has been changed so that after a successful update the agent only shows the final successful event. SF06207160/SEG-160085/DSSEG-7765
 - Deep Security Agent crashes and issues connecting with Deep Security Manager caused Anti-Malware Offline events. SF06061098/SEG-154701/DS-74665
 - With Web Reputation Enabled, some characters entered in console commands were not being parsed properly. For example, an underscore (`_`) entered in a command was replaced with a dash (`-`), and an uppercase Z was replaced with a lowercase z. DS-74335
 - With Activity Monitoring enabled, a connectivity issue caused Deep Security agents to appear offline for some Trend Micro Cloud One - Workload Security customers. The agent introducing this issue is no longer available. For more details, see [Removal of Deep Security Agent 20.0.0-5953 for Linux](#). SEG-161456
 - With Activity Monitoring enabled, the internal MQTT channel sometimes became inaccessible. This caused high CPU usage and Deep Security Agent errors (`MQTT offline, hub is busy, cannot connect to dsa-connect`) as well as Trend Micro Vision One connectivity loss and the inability to send telemetry. SEG-160263/SEG-161138/SEG-160116/SEG-159318/DS-74638/DS-75367/DS-75193
 - Application Control sometimes failed to block programs running in namespace mode. SF05929869/SEG-151363/DS-74116
 - Integrity Monitoring sometimes failed to create events after running certain console commands (for example, `passwd` or `mv` commands). 05718251/SEG-148552/DS-72643
 - Older Application Control events were not being removed from the database as intended, causing the `events.db` file size to increase indefinitely. SF06172729/SEG-159548/DS-74706
 - When Integrity Monitoring event generation is interrupted by a process or system crash, it could lead to incorrect events being created. SF05508030/SEG-138756/DS-72470
-

Known issues

- Deep Security Agent is having connectivity issues on some systems, resulting in "Event ID 9012, Smart Protection Server Disconnected for Smart Scan" error messages. For more details including temporary workaround instructions, see https://success.trendmicro.com/dcx/s/solution/000292267?language=en_US. SF06512673/SEG-168468

Deep Security Agent - 20.0.0-5953 (20 LTS Update 2022-11-22)

Release date: November 22, 2022

Build number: 20.0.0-5953

New feature

Agent self-protection: This feature helps prevent users on the local system from tampering with the agent. For more information, and help configuring agent self-protection, see [Enable or disable agent self-protection in Linux](#).

Enhancements

- Deep Security Agent 20.0.0-5953 or later with Deep Security Manager 20.0.711 or later now supports FIPS mode for Oracle Linux 8.

Resolved issues

- With Activity Monitoring enabled, the internal MQTT channel sometimes became inaccessible. This caused Deep Security Agent errors (`MQTT offline, hub is busy, cannot connect to dsa-connect`) as well as Trend Micro Vision One connectivity loss and the inability to send telemetry. SEG-160263/SEG-161138/SEG-160116/SEG-159318/DS-74638
 - Application Control sometimes failed to block programs running in namespace mode. SF05929869/SEG-151363/DS-74116
 - Integrity Monitoring sometimes failed to create events after running certain console commands (for example, `passwd` or `mv` commands). 05718251/SEG-148552/DS-72643
-

- Older Application Control events were not being removed from the database as intended, causing the `events.db` file size to increase indefinitely. SF06172729/SEG-159548/DS-74706
- When Integrity Monitoring event generation is interrupted by a process or system crash, it could lead to incorrect events being created. SF05508030/SEG-138756/DS-72470

Known issues

With Activity Monitoring enabled, a connectivity issue causes Deep Security agents to appear offline for some Trend Micro Cloud One - Workload Security customers. This issue can be mitigated by restarting the `dsa-connect` or `ds_agent` services. For more details, see [Removal of Deep Security Agent 20.0.0-5953 for Linux](#). SEG-161456

Deep Security Agent - 20.0.0-5761 (20 LTS Update 2022-10-21)

Release date: October 21, 2022

Build number: 20.0.0-5761

New feature

Enhanced platform support

- SAP Scanner support for Oracle Linux 7: Deep Security Agent for Oracle Linux 7 now supports SAP Scanner. VO-1849

Enhancements

- Updated Deep Security Agent to include additional metadata, such as `UserAgent` and `Referrer`, for Web Reputation Services. DS-72196
- Updated Deep Security Agent to include the Integrity Monitoring database in the agent diagnostic package. DS-73293
- Updated Deep Security Agent to support NULL cipher when inspecting TLS traffic with Intrusion Prevention. DS-71085
- Deep Security Agent now can be deployed without additional dependency on System V packages. DS-73588

Resolved issues

- With Activity Monitoring enabled, Deep Security Agent encountered a resource leak that caused system crashes, high memory usage affecting other applications, and agent connectivity issues leading to large numbers of reconnect attempts. SEG-154142/SEG-155126/SEG-156653/SEG-157277/SEG-156052/SEG-157254/SEG-156483
- With Log Inspection enabled, Deep Security Agent sometimes generated "Abnormal Restart Detected" events. SF05951130/SEG-151372/DS-73737
- If the Deep Security Agent service stopped while running Application Control in Maintenance Mode, executable files created after the service stopped were not being auto-approved as intended. SF05961688/SEG-152045/DS-73570
- With Advanced TLS traffic inspection enabled, Deep Security Agent had a memory issue that prevented some applications from running. SEG-150631/DS-74039
- Software, if renamed or copied while Application Control had Maintenance Mode enabled, would remain authorized in the software inventory under its original filename or location. DS-74015
- Virtual Machines using vMotion sometimes deactivated unexpectedly and displayed an "Offline (Activation required)" status. SEG-153050/DS-73807
- The TLS inspection support package failed to download on Deep Security Agents using Edge Relay. DS-73789
- On RedHat Enterprise Linux computers, Anti-Malware being enabled would sometimes cause a system crash. SEG-155143/DS-74008

Deep Security Agent - 20.0.0-5512 (20 LTS Update 2022-09-22)

Release date: September 22, 2022

Build number: 20.0.0-5512

Enhancements

- Updated Deep Security Agent kernel device module files to comply with Security-Enhanced Linux (SELinux) requirements. DSSEG-7378

- Deep Security Agent now reports host information with additional details. DS-72609
- Deep Security Agent now reports host metadata for installed software with additional details. DS-72608
- Updated Deep Security Agent to add multi-thread support for On-Demand scan and Scheduled Scan. DS-72797/DS-72798
- Deep Security Agent with Deep Security Manager 20.0.677 or later now supports the automatic update of Advanced TLS Traffic Inspection as operating system libraries change (**Computer** or **Policy** > **Settings** > **TLS Inspection Package Update**). DS-72828

Resolved issues

- Trust Entities settings were not being re-applied after turning Application Control off and back on again. SF05930535/SEG-152439/DS-73312
- When installed on a system that uses secure boot without importing the required sign key, Deep Security Agent generated an Anti-Malware Engine error code with "Reason ID: 13" when it should have generated the code with "Reason ID: 11". For details on Reason IDs, see [Warning: Anti-Malware Engine has only Basic Functions](#). DS-72891
- Deep Security Agent reported host metadata in an unexpected format. DS-73411

Security updates

Security updates are included in this release. For more information about how Trend Micro protects against vulnerabilities, visit [Vulnerability Response](#). Note that in line with responsible disclosure practices, CVE details will only be made available for select security updates once patches have been made available for all impacted releases. VRTS-8100/VRTS-8101/DS-73087/DS-72528

Highest CVSS score: 7.0

Highest severity: High

Known issues

- With Activity Monitoring enabled, Deep Security Agent encountered a resource leak that caused system crashes, high memory usage affecting other applications,

and agent connectivity issues leading to large numbers of reconnect attempts.
SEG-154142/SEG-155126/SEG-156653/SEG-157277/SEG-156052/SEG-
157254/SEG-156483

Deep Security Agent - 20.0.0-5394 (20 LTS Update 2022-08-29)

Release date: August 29, 2022

Build number: 20.0.0-5394

New features

Ubuntu 22.04 (AWS ARM-based Graviton 2) support: Deep Security Agent 20.0.0-5394 or later with Deep Security Manager 20.0.677 or later is now supported on Ubuntu 22.04 (AWS ARM-based Graviton 2).

Enhancements

- The Deep Security Agent process now restarts automatically if the file descriptor count is abnormally high, and a counter was added to track how many times this event occurs. SF05212995/SEG-130431/DS-72616
- Application Control now detects software changes for executables with non executable extensions. DS-70805
- Updated Deep Security Agent to add support for inspecting packets using dynamic ports in a TLS connection. DS-71078
- Updated Deep Security Agent to add more metrics for Advanced TLS Inspection. DS-72833

Resolved issues

- When TLS inspection was done on a UDP connection with dynamic ports, the operating system would sometimes crash. SEG-151169/DS-73043
- Log Inspection Engine would go offline when using '\$' character in match or regex fields together with variables. SEG-146965/SEG-146966/DS-72325
- Anti-Malware would sometimes leak file descriptors. SF05212995/SEG-130431/DS-72979

- When assigning a policy with real-time Anti-Malware turned off to a new guest VM, it would sometimes turn off real-time Anti-Malware for all other guest VMs registered to the same Deep Security Virtual Appliance. SEG-146057/DS-72856
- Application Control would still block access to network files while in maintenance mode. SF04922652/SEG-131710/DS-72037
- When Application Control is enabled, Adobe plugins were generating unexpected security events. SF05823607/SEG-148570/DS-72679
- Deep Security Agent would return "revision mismatch (-10039)" errors when loading certain configuration files during an agent update. DS-72499
- Deep Security Agent would report detected software changes before Application Control inventory scan was completed. DS-72071
- Patched third-party libraries. Before patch, the Deep Security Virtual Appliance agent would sometimes crash. SF05559993/SEG-140234/DS-72510

Known issues

- When executing multiple custom script tasks, new tasks are currently overwritten by previous unfinished tasks. You can execute custom script tasks one by one to bypass this issue. Note that this issue will be fixed in a future release. DS-72699

Deep Security Agent - 20.0.0-5137 (20 LTS Update 2022-07-26)

Release date: July 26, 2022

Build number: 20.0.0-5137

New features

Advanced TLS Traffic Inspection: Deep Security Agent 20.0.0-5137 or later adds Advanced TLS Traffic Inspection support to platforms that run system updates or package updates. Note that this feature is currently only supported for Trend Cloud One - Workload Security. Support for Deep Security Manager (On-Premise) will be added later.

Red Hat 9 support: Deep Security Agent 20.0.0-5137 or later with Deep Security Manager 20.0.651 or later now supports Red Hat 9.

Amazon Linux 2 support: Deep Security Agent 20.0.0-5137 or later with Deep Security Manager 20.0.651 or later now supports Amazon Linux 2 for AWS Graviton 3.

Enhancements

- Updated Deep Security Agent to add Anti-Malware support for Red Hat OpenShift. DS-72368
- Updated Deep Security Agent to reduce CPU usage and improve container performance for real-time Anti-Malware scanning. Previously, all files were scanned during read/write. Now, Anti-Malware file scanning during write is deferred (the file is added to a queue and scanned in the background). DS-65581
- Deep Security Agent Scanner (SAP) now generates infection reports with additional details. DS-71660
- Updated Deep Security Agent to improve the "zero-config" SSL process for outbound connections. DS-70715
- Updated Deep Security Agent to improve Trust Entities functionality. Trust rule wildcard support now includes globstar `***` which matches many sub directories. Single star `*` now only matches within your current directory. Existing rules that used a single star `*` to match many folders no longer work and need to be changed to use a globstar `***`. DS-71817

Resolved issues

- Deep Security Agent Scanner (SAP) sometimes displayed duplicate Anti-Malware events for .SAR file types. DS-71879
- Deep Security Agent SAP scanner could not detect the MIME (.TTF) files. DS-55897
- Intrusion Prevention rules with certain setting combinations failed to compile. DS-71889
- Deep Security Agent had connectivity issues on some systems. DS-72219

Security updates

Security updates are included in this release. For more information about how Trend Micro protects against vulnerabilities, visit [Vulnerability Response](#). Note that in line with responsible disclosure practices, CVE details will only be made available for select

security updates once patches have been made available for all impacted releases. VRTS-7102/VRTS-7070/VRTS-7041/VRTS-7039/DSSEG-7636

Highest CVSS score: 4.4

Highest severity: Medium

Known issues

- When executing multiple custom script tasks, new tasks are currently overwritten by previous unfinished tasks. You can execute custom script tasks one by one to bypass this issue. Note that this issue will be fixed in a future release. DS-72699

Deep Security Agent - 20.0.0-4959 (20 LTS Update 2022-07-04)

Release date: July 4, 2022

Build number: 20.0.0-4959

New features

Ubuntu 22.04: Deep Security Agent 20.0.0-4959 or later now supports Ubuntu 22.04. This requires Deep Security Manager 20.0.651 or later.

FIPS mode on Ubuntu 20.04: Deep Security Agent 20.0.0-4959 or later now supports FIPS mode for Ubuntu 20.04.

Enhancements

- Deep Security Agent 20.0.0-4959 or later with Deep Security Manager 20.0.0-414 or later now has improved Anti-Malware support on systems using Fanotify. Previously, "Anti-Malware Engine Offline" events interrupted Anti-Malware function on these systems. Now, an Anti-Malware with basic functions event is recorded and users maintain basic file scanning function, but not advanced scan mechanisms such as Predictive Machine Learning. DS-68552

Resolved issues

- Deep Security Agent Scanner (SAP) had a connectivity issue preventing it from loading the correct libraries on some systems. DS-71623

- Deep Security Agent Scanner library sometimes caused SAP applications to crash. DS-71849
- Anti-Malware was unable to remove immutable or append-only files on some systems. VRTS-7110/DS-52383
- Using the command line (`dsa_control -b`), Deep Security Relay failed to extract the bundle file required to update in a closed network environment. SF05715642/SEG-144571/DSSEG-7600
- With Log Inspection enabled, upgrades to Deep Security Agents 20.0.0-4726 encountered "Get Events Failed" and "Command Not Found" alerts. SF05738607/SEG-145679/DS-72117
- When Anti-Malware is enabled alongside either Integrity Monitoring or Activity Monitoring, Deep Security Agent caused high CPU usage. SF05169148/SEG-129522/DS-69594
- With Anti-Malware enabled, Deep Security Agent sometimes crashed operating systems that were undergoing an ISO backup. SF05532786/SEG-139280/DS-71299
- Updated Deep Security Agent to immediately report its status to Deep Security Manager when Application Control's maintenance mode is enabled on the agent. DS-71617
- Deep Security Agent sometimes created unclear error log entries referencing "invalid" or "badly-formed" proxy URLs. SEG-144613/DS-71866

Deep Security Agent - 20.0.0-4726 (20 LTS Update 2022-05-31)

Release date: May 31, 2022

Build number: 20.0.0-4726

Enhancements

- Updated Deep Security Relay to record its status and other metrics for potential troubleshooting. DS-65763

Resolved issues

- Trust Entities "allow by target" rules sometimes blocked processes they weren't intended to block. SF04922652/SEG-131710/DS-71060
- Deep Security Agent reported false positive "Created/Deleted" Integrity Monitoring events under some configurations. SF05434164/SEG-136425/DS-70656
- With Activity Monitoring enabled, Deep Security Agent had high system CPU usage when events were being generated rapidly. 05107582/SEG-128170/DS-71486
- Deep Security Agent Scanner library didn't work properly with highly-interrupted SAP applications on Linux systems. This resulted in files were scanned, but results might be unable to report to the SAP applications. SF05390384/SEG-136659/DS-71251
- Following an upgrade, Deep Security Agent would send continuous "Security update in progress" reports to Deep Security Manager. SF05253107/SEG-131983/DS-69747
- Updated Deep Security Relay to prevent Deep Security Agent from retrieving incomplete signature files for packages. SF05332854/SEG-134394/DS-71228
- Deep Security Agent had connectivity issues caused when a Server Name Indicator (SNI) used an invalid format. SEG-127761/DS-70806
- An abnormal restart of Deep Security Agent sometimes lead to "Anti-Malware Engine Offline" errors. SEG-140234/DS-71333
- Secondary DNS setting from IP pool was not configured when Appliance was deployed. SF05215036/SEG-134844/DSSEG-7535

Security updates

Security updates are included in this release. For more information about how Trend Micro protects against vulnerabilities, visit [Vulnerability Response](#). Note that in line with responsible disclosure practices, CVE details will only be made available for select security updates once patches have been made available for all impacted releases. DS-52329

Highest CVSS score: 7.5

Highest severity: High

Deep Security Agent - 20.0.0-4416 (20 LTS Update 2022-04-28)

Release date: April 28, 2022

Build number: 20.0.0-4416

Enhancements

- Updated Deep Security Agent to improve Intrusion Prevention performance when the "Bypass Network Scanner" rule was applied. DS-69515

Resolved issues

- With Intrusion Prevention enabled, a packet transmission error caused some systems to crash. SEG-136843/DSSEG-7524

Security updates

Security updates are included in this release. For more information about how Trend Micro protects against vulnerabilities, visit [Vulnerability Response](#). Note that in line with responsible disclosure practices, CVE details will only be made available for select security updates once patches have been made available for all impacted releases. VRTS-7132/DS-70518

Highest CVSS score: 7.5

Highest severity: High

Deep Security Agent - 20.0.0-4185 (20 LTS Update 2022-04-06)

Release date: April 6, 2022

Build number: 20.0.0-4185

New features

Advanced TLS traffic inspection: Advanced TLS traffic inspection adds the capability for inspecting TLS traffic encrypted with modern ciphers, including Perfect Forward Secrecy (PFS). It also enhances virtual patching for HTTPS servers to help protect against vulnerabilities such as Log4j.

Resolved issues

- Running an Anti-Malware manual scan using the command line sometimes made Deep Security Agent unable to receive incoming connections. SF05385865/SEG-135256/DS-70364
- Deep Security Agent created an "Application Control Engine Offline" error during agent upgrade, and an "Application Control Engine Online Again" message after upgrade completion. Note that an upgrade should not have triggered these events. DS-69888
- Application Control sometimes blocked unrecognized software even when running in maintenance mode. SF05234969/SEG-133594/DS-69752
- Deep Security Agent had SSL connectivity issues when Web Reputation Service was enabled. DS-67675
- Deep Security Agent sometimes consumed a high amount of system resources during policy updates. SEG-134417/DS-69810

Deep Security Agent - 20.0.0-3964 (20 LTS Update 2022-03-01)

Release date: March 1, 2022

Build number: 20.0.0-3964

New features

Threat Intelligence: Threat Intelligence (formerly known as Connected Threat Defense) provides enhanced malware protection for new and emerging threats. For more information, see [Detect emerging threats using Threat Intelligence](#).

Enhanced platform support

- **Deep Security Agent 20.0.0-3964 or later is now supported on these platforms:**
 - Red Hat 8 (AWS ARM-Based Graviton 2) (requires Deep Security Manager 20.0.605+)
 - Debian 11 (requires Deep Security Manager 20.0.605+)

Enhancements

- Updated Deep Security Agent to exclude suspicious characters, such as \$, found in strings from the "Original IP (XFF)" field for Intrusion Prevention events. SEG-129905/DS-68989

Resolved issues

- With real-time Integrity Monitoring enabled, Integrity Monitoring delete events were not being generated after editing a file and then deleting it. DS-69057
- Deep Security Agent caused high CPU usage for systems protecting containers. Container protection can now be enabled or disabled in Deep Security Manager (from **Computer** (or **Policy**) > **Settings** > **Container Protection**). SEG-115751/DSSEG-7334

Deep Security Agent - 20.0.0-3770 (20 LTS Update 2022-01-24)

Release date: January 24, 2022

Build number: 20.0.0-3770

New features

Zero config IPS inspection: Deep Security Agent adds the capability for Intrusion Prevention to inspect TLS encrypted traffic without manually importing certificates. This adds support for more cipher suites as well. This feature is being rolled out gradually for Linux platforms, beginning with Trend Micro Cloud One - Workload Security customers.

CRI-O support: A Deep Security Agent's "CRI-O engine version" is now displayed in Deep Security Manager, as well as Anti-Malware event information for containers. Note that CRI-O is currently only supported for Deep Security Manager (On-Premise). Support for Trend Micro - Cloud One Workload Security will be added later.

Enhancements

- Updated Deep Security Agent to allow Intrusion Prevention to connect to Deep Security Manager if the manager is using TLS 1.2 strong ciphers. DS-69042
-

- Updated Deep Security Agent to correctly display the host's IP address in the "LastIpUsed" field. Previously, the field displayed the load balancer or proxy IP in environments using one of those. SF05283977/SEG-133073

Resolved issues

- A Deep Security Agent conflict with network interface controllers (NICs) caused systems with multiple NICs to crash. 05048124/SEG-126094/DS-68730
- When an Integrity Monitoring scan timed out, it sometimes generated false "create" or "delete" events for "user" or "group" entities. SEG-117739/DS-66885
- Application Control, Anti-Malware, and Real-time Integrity Monitoring failed to function properly for Deep Security Agents with certain combinations of Integrity Monitoring rules configured. DS-68494
- With Activity Monitoring enabled, Deep Security Agent caused high CPU usage. DS-62849
- A Deep Security Agent parsing issue was causing "Anti-Malware Engine Offline" errors. SF05171312/SEG-129367/DSSEG-7428

Security updates

Security updates are included in this release. For more information about how Trend Micro protects against vulnerabilities, visit [Vulnerability Response](#). Note that in line with responsible disclosure practices, CVE details will only be made available for select security updates once patches have been made available for all impacted releases. DS-68180

Highest CVSS score: 9.1

Highest severity: High

Deep Security Agent - 20.0.0-3445 (20 LTS Update 2021-11-24)

Release date: November 24, 2021

Build number: 20.0.0-3445

New features

Collection of the agent metrics in the on-premise environment: You can now collect the agent metrics on-premises for SEG troubleshooting purposes. These metrics are stored as ZIP files on Windows in the `C:\ProgramData\Trend Micro\Deep Security Agent\metrics` directory and on Linux, AIX, and Solaris in the `/var/opt/ds_agent/metrics` directory. The ZIP files are rotated periodically on the local file system. Each ZIP file is approximately 1 MB in size and contains up to 100 files. The metrics are collected along with the diagnostic package.

Enhancements

- Deep Security Agent sometimes crashed when it could not connect to Deep Security Manager. DS-67654
- Deep Security Agent no longer uses CBC cipher suites by default in order to improve security. DS-67204
- Deep Security Agent was upgraded to use locally installed kernel modules when new ones can't be fetched from the Deep Security Relay. DS-66599
- Updated Deep Security Agent to support using the "process name" property in "ignore from source" rules for [Application Control Trust Entities](#) on Cloud One Workload Security. DS-67322
- Updated Deep Security Agent's database size management to optimize disk space usage. DS-67347

Resolved issues

- Insufficient file access permission for the Deep Security Relay sometimes caused the agent installer to fail. DS-67278
 - Deep Security Agent sometimes showed an incorrect "No such file or directory" error message during installation. DS-67317
 - Deep Security Agent sometimes showed plugin installation failures during an upgrade even when the upgrade was successful. DS-67336
 - Deep Security Agent sometimes could not start after an upgrade. SF04943063/SEG-123155/DS-67475
 - Deep Security Agent sometimes changed the access time of files during the on-demand Anti-Malware scan. DS-67119
-

- The Deep Security Agent and MQTT connection would sometimes go offline, requiring an agent restart. DS-67487
- Deep Security Agent couldn't properly handle SAP NetWeaver MIME type scan requests containing leading and trailing spaces. DS-67448
- With Anti-Malware real-time scan enabled, Deep Security Agent would sometimes scan unchanged files. DS-67806
- Deep Security Agent sometimes caused the system to crash. SEG-123338/DS-67445

Security updates

Security updates are included in this release. For more information about how Trend Micro protects against vulnerabilities, visit [Vulnerability Response](#). Note that in line with responsible disclosure practices, CVE details will only be made available for select security updates once patches have been made available for all impacted releases. VRTS-6489/DSSEG-7210/DS-65113/DS-67367

Highest CVSS score: 9.8

Highest severity: High

Deep Security Agent - 20.0.0-3288 (20 LTS Update 2021-10-28)

Release date: October 28, 2021

Build number: 20.0.0-3288

New features

Kernel support package updates: You can now choose when to perform kernel support package updates, using the new "Automatically update kernel package when agent restarts" option in the computer or policy editor.

Evolution of the agent installer: The Deep Security Agent installer now installs most agent content. This results in the following changes:

- Agent size requirements have increased, including a slightly larger installer package on most platforms.

- All agent content is now installed on the computer being protected. Content remains unloaded on a computer until a plug-in is activated by a policy or by the manager console.
- The agent is now much less dependent on relays because all plug-in installations use the content already installed with the agent. This mitigates plug-in install issues due to relay communications because plug-ins can be installed without a connection to a relay.

Enhanced platform support

- **Deep Security Agent 20.0.0-3288 or later now supports these platforms:**
 - AlmaLinux 8 (requires Deep Security Manager 20.0.503+)
 - Rocky Linux 8 (requires Deep Security Manager 20.0.543+)
 - Ubuntu 20.04 (AWS ARM-Based Graviton 2) (requires Deep Security Manager 20.0.503+)
 - Ubuntu 18.04 (AWS ARM-Based Graviton 2) (requires Deep Security Manager 20.0.482+)
- **Secure boot support:** Deep Security Agent now supports Oracle Linux 7 (in both UEK-R5 and UEK-R6) and Oracle Linux 8 with Secure Boot enabled.

Enhancements

- Deep Security Agent 10.0 to 20.0 upgrades now keep their "NIC bypass" configuration (used for [bypassing a network interface](#)). DS-64985
- You can now exclude container file events from the kernel module. DS-65547

Resolved issues

- Anti-Malware updates sometimes failed, resulting in "Security Update: Pattern Update on Agents/Appliances Failed" errors. 04763356/SEG-119138/DS-66569
 - The Deep Security Agent Scanner library sometimes couldn't be loaded by SAP NetWeaver. DS-67530
 - With Intrusion Protection enabled, Deep Security Agent caused the system to crash under some configurations. SF04931669/SEG-123338/DS-67441
-

- With SAP integrated and running, Deep Security Agent would block MP4 files. 04660120/SEG-117094/DSSEG-7254
- Deep Security Agent sometimes was unable to connect to the manager via proxies. DS-65929
- Deep Security Agent sometimes showed package signature errors during an upgrade because of a mismatched Certification Revocation List (CRL). DS-65056

Security updates

Security updates are included in this release. For more information about how Trend Micro protects against vulnerabilities, visit [Vulnerability Response](#). Note that in line with responsible disclosure practices, CVE details will only be made available for select security updates once patches have been made available for all impacted releases. DS-46018/DSSEG-7210/DSSEG-7217

Highest CVSS score: 7.8

Highest severity: High

Deep Security Agent - 20.0.0-3165 (20 LTS Update 2021-10-08)

Release date: October 08, 2021

Build number: 20.0.0-3165

Note: Deep Security Agent 20.0.0.3165 has been released to Trend Micro Cloud One - Workload Security customers. However, it is not available on the Deep Security Agent software download page or released to customers using Deep Security Manager.

New features

- **AlmaLinux 8 support:** Deep Security Agent is now supported on AlmaLinux 8.
- **Ubuntu 18.04 (AWS ARM-Based Graviton 2) support:** Deep Security Agent is now supported on Ubuntu 18.04 (AWS ARM-Based Graviton 2).
- **Oracle Linux 7 support:** Deep Security Agent is now supported on Oracle Linux 7 with Secure Boot (in both uek-R5 and uek-R6).

- **Kernel support package updates:** You can now choose when to perform kernel support package updates, using the new **Automatically update kernel package when agent restarts** option in the computer or policy editor.
- **Evolution of the agent installer:** The Deep Security Agent installer now installs most agent content. This results in the following changes:
 - Agent size requirements have increased, including a slightly larger installer package on most platforms.
 - All agent content is now installed on the computer being protected. Content remains unloaded on a computer until a plug-in is activated by a policy or by the manager console.
 - The agent is now much less dependent on relays because all plug-in installations use the content already installed with the agent. This mitigates plug-in install issues due to relay communications because plug-ins can be installed without a connection to a relay.

Enhancements

- Updated Deep Security Agent to prevent agents upgraded from version 10.0 to 20.0 from losing their "NIC bypass" configuration (used for [bypassing a network interface](#)). DS-64985
- You can now exclude container file events from the kernel module. DS-65547

Resolved issues

- Deep Security Agent sometimes was unable to connect to Manager via proxies. DS-65929

Security updates

Security updates are included in this release. For more information about how Trend Micro protects against vulnerabilities, visit [Vulnerability Response](#). Note that in line with responsible disclosure practices, CVE details will only be made available for select security updates once patches have been made available for all impacted releases. DSSEG-7210/DSSEG-7217

Highest CVSS score: 7.8

Highest severity: High

Deep Security Agent - 20.0.0-2971 (20 LTS Update 2021-09-08)

Release date: September 08, 2021

Build number: 20.0.0-2971

New features

FIPS mode on Red Hat Enterprise Linux 8: Deep Security Agent 20.0.0-2971 or later now supports FIPS mode for Red Hat Enterprise Linux 8.

FIPS mode on Amazon Linux 2: Deep Security Agent 20.0.0-2971 or later now supports FIPS mode for Amazon Linux 2.

Enhancements

- Updated Deep Security Agent to improve performance and compatibility by using a unified driver for file, process, and network events. DS-61784
- Updated Deep Security Agent to improve TLS traffic inspection. This feature is being rolled out gradually, beginning with Trend Micro Cloud One - Workload Security customers. DS-15576
- Updated Deep Security Agent to improve connectivity with Deep Security Manager during agent deployment and activation. DS-62547

Resolved issues

- Deep Security Agent sometimes caused performance issues on systems with folders in NFS format. SF04816680/SEG-118993/DS-66280
 - With Integrity Monitoring enabled, Deep Security Agent sometimes caused high CPU usage. DS-65986
 - Deep Security Agent 20.0.0-2740 for Linux was causing performance and third-party compatibility issues on some systems. This agent was removed from the [Trend Micro Download Center](#). For more information see [Removal of Deep Security Agent \(DSA\) Build 20.0.0-2740 for Linux from Download Center](#).
 - Deep Security Agent console commands sometimes failed to return proxy information for Deep Security Relay or Deep Security Manager. DS-65419
-

- Deep Security Agent sometimes failed to properly display items under **Events and Reports**. DSSEG-7057
- Deep Security Agent was sometimes unable to create or manage tasks on RPM-based platforms due to a SystemD (Linux service manager) process limitation. SF04543580/SEG-113833/DS-65550
- Deep Security Agent Anti-Malware Real-Time Scan exclusions sometimes failed within container environments. DS-65528
- Deep Security Agent Anti-Malware Real-Time Scan directory exclusions sometimes failed if filenames were not in UTF-8 format. SEG-115198/DS-65495
- With Anti-Malware enabled, Deep Security Agent encountered an "Insufficient Disk Space" alert which sometimes crashed the agent or stopped other programs from working properly. SF04584157/SEG-113377/DS-64405
- Deep Security Agent failed to execute some agent-initiated (dsa_control) console commands. 04564385/SEG-112050/DSSEG-6990
- Deep Security Agent sometimes crashed while trying to establish a connection with Deep Security Manager. 04634804/SEG-113539/DS-64862
- Deep Security Agent sometimes lost connectivity while trying to establish an SSL connection. SF04323898/SEG-107451/DS-64268
- Deep Security Agent was sometimes unable to connect to web applications on systems with older OS versions. SF04451029/SEG-109652/DS-64528
- Deep Security Agent upgrade (**Administration > Updates > Software**) sometimes failed if a previous (RPM package) upgrade was triggered using console commands. SF04586071/SEG-113583/DS-64978
- With Web Reputation enabled, Deep Security Agent caused connectivity issues for some third-party software. SF04072723/SEG-97952/DSSEG-6963
- With Integrity Monitoring enabled, Deep Security Manager caused high CPU usage on the authentication server for some systems. 04488319/SEG-110088/DS-63855
- With Integrity Monitoring real-time scan enabled, Deep Security Agent sometimes prevented files on network drives from being deleted. SEG-108636/C1WS-1787

Security updates

Security updates are included in this release. For more information about how Trend Micro protects against vulnerabilities, visit [Vulnerability Response](#). Note that in line with responsible disclosure practices, CVE details will only be made available for select security updates once patches have been made available for all impacted releases. SF04613197/SEG-113566/DS-64050

Highest CVSS score: 9.8

Highest severity: High

Deep Security Agent - 20.0.0-2593 (20 LTS Update 2021-07-01)

Release date: July 01, 2021

Build number: 20.0.0-2593

New feature

FIPS mode on Ubuntu 18.04: Deep Security Agent 20.0.0-2593 or later now supports FIPS mode for Ubuntu 18.04.

Resolved issues

- Integrity Monitoring alerts sometimes triggered but did not appear in the **Events and Reports** tab. 04266346/SEG-103731/DS-62992
- Deep Security Agent sometimes triggered multiple "Log Inspection Engine Initialized" alerts due to an agent-manager communication issue. SF03968169/SEG-95731/DS-60840
- The MQTT connection sometimes went offline when Deep Security Agent had Activity Monitoring enabled. SF04216172/SEG-101691/DS-63458
- Application Control was detecting multiple "Application Control Software Changes Detected" events due to ".tmp" files being generated by PowerShell. C1WS-1608

Security updates

Security updates are included in this release. For more information about how Trend Micro protects against vulnerabilities, visit [Vulnerability Response](#). Note that in line with

responsible disclosure practices, CVE details will only be made available for select security updates once patches have been made available for all impacted releases. VRTS-5850/DS-54705

Highest CVSS score: 4.4

Highest severity: Medium

Deep Security Agent - 20.0.0-2395 (20 LTS Update 2021-05-24)

Release date: May 24, 2021

Build number: 20.0.0-2395

New features

Enhanced platform support

- Application Control and Integrity Monitoring for Amazon Linux 2 (AWS ARM-Based Graviton 2): Deep Security Agent now supports Application Control and Integrity Monitoring for Amazon Linux 2 on AWS Graviton 2. DS-62775
- Activity Monitoring for Amazon Linux 2 (AWS ARM-Based Graviton 2): Deep Security Agent now supports Activity Monitoring for Amazon Linux 2 on AWS Graviton 2.

Enhancements

- Deep Security Agent 20.0.0-2395 or later now supports Entrust Root Certificate Authority (G2) certificates. Non-G2 security certificates expire on 2022/07/09. After that date, only Deep Security Agent 20.0.0-2395 or later will have the latest Anti-Malware Smart Scan protection. DS-63010
- Updated Deep Security Agent to add Predictive Machine Learning support for Malware Scan on Linux platforms. DS-62857
- Updated Deep Security Agent's Anti-Malware default configuration to monitor file access from the local host only, improving compatibility for some file systems. DS-62222

Resolved issues

- Anti-Malware Real-Time Scan sometimes didn't detect files properly with the "During read" setting selected (**Computers > Details > Anti-Malware > General > Real-Time Scan > Malware Scan Configuration > Edit > Advanced > Real-Time Scan**). SEG-104496/DS-61836
- Deep Security Agent was unable to install in some environments because it misidentified the OS. DSSEG-2915/DS-28321
- Deep Security Agent sometimes showed package signature errors during an upgrade because of a mismatched Certification Revocation List (CRL). DS-62154
- Anti-Malware Real-Time Scan sometimes caused high CPU usage. 04331007/SEG-107814/DS-62593
- Insufficient host information caused by connectivity issues sometimes resulted in offline or duplicate listings in the **Computers** tab for Deep Security Agents on AWS workspaces. SF04198134/SEG-102818/DS-61666
- Anti-Malware Real-Time Scan caused unintentional file changes under some configurations. DS-62412
- Deep Security Agent sometimes couldn't successfully perform an upgrade because of a missing package. SF04302125/SEG-104084/DS-62692
- Anti-Malware kernel modules sometimes didn't bypass file activity on remote shared storages when Network Directory Scan was disabled. DS-62985

Deep Security Agent - 20.0.0-2204 (20 LTS Update 2021-04-12)

Release date: April 12, 2021

Build number: 20.0.0-2204

New feature

Enhanced platform support

- Anti-Malware and Log Inspection support for Amazon Linux 2 (AWS ARM-Based Graviton 2): Deep Security Agent 20.0.0-2204 or later now supports the Anti-Malware, Firewall, Intrusion Prevention, Log Inspection, and Web Reputation protection modules. Note that Advanced Threat Scan Engine (ATSE) update is

not currently supported for Amazon Linux 2 on AWS Graviton 2, but will be added in a future release.

Resolved issues

- With Anti-Malware enabled, Deep Security Agent sometimes caused "defunct processes" (that is, processes that remain in the system process table after they've completed execution). SEG-104452/DS-61593
- When Application Control was in block mode, it was unable to build a proper software inventory in some cases. DS-58813
- When Web Reputation was enabled, the system sometimes crashed. SF04258834/SEG-102756/DS-61067
- When Integrity Monitoring real-time scan was enabled, sometimes directories on NFS volumes couldn't be removed. SF03977538/SEG-98656/DS-61062
- When Intrusion Prevention was enabled, the system would crash under some configurations. SF04286712/SEG-103971/DS-61274
- A proxy server issue sometimes caused connectivity issues with Deep Security Agents after registering with Trend Micro Vision One (XDR). SF04318864/SEG-104847/DS-61516

Deep Security Agent - 20.0.0-2009 (20 LTS Update 2021-03-08)

Release date: March 08, 2021

Build number: 20.0.0-2009

Enhancements

- Updated Deep Security Agent to include CPU information (number of logical cores) to improve diagnostics and performance tracking. DS-60011

Resolved issues

- The MQTT connection went offline because an old MQTT connection was not properly cleaned. SF04236908/SEG-102056/DS-60893
- When Firewall, Intrusion Prevention, and Web Reputation were enabled, the system sometimes crashed. SF03992370/SEG-100828/DS-60589

- After restarting Deep Security Virtual Appliance, protected VMs sometimes became inaccessible. SEG-94723/SF03949466/DS-58962

Deep Security Agent - 20.0.0-1876 (20 LTS Update 2021-02-08)

Release date: February 08, 2021

Build number: 20.0.0-1876

Resolved issues

- The Deep Security Agent was sometimes unable to establish an SSL connection to the web server. DS-59893
- Activity Monitoring data could not be transferred to XDR because a proxy connection was established without a relevant port. SEG-97519

Deep Security Agent - 20.0.0-1822 (20 LTS Update 2021-01-18)

Release date: January 20, 2021

Build number: 20.0.0-1822

New features

Enhanced platform support

- Amazon Linux 2 (AWS ARM-Based Graviton 2): Deep Security Agent now supports Amazon Linux 2 on AWS Graviton 2. The agent currently supports the Firewall, Intrusion Prevention, and Web Reputation protection modules. Other protection modules are coming soon.

Behavior Monitoring for Linux: This release adds support for Behavior Monitoring on the Linux platform.

Deep Security Agent - 20.0.0-1681 (20 LTS Update 2021-01-04)

Release date: January 04, 2021

Build number: 20.0.0-1681

Resolved issues

- A driver conflict was causing the Deep Security Agent to hang and require a reboot. SEG-94278/SF03941184/DS-59020
- If an error related to Secure Boot occurs, the user is no longer blocked from installing the plugins and receive a "Secure Boot" error message on Deep Security Manager. Instead, an "Engine is offline" error message is displayed. Users can check "Secure Boot" entries in ds_agent.log for error details. DS-58374
- In the SecureBoot environment, the SUSE15 SP2 kernel module load failed with kernel version 5.3.18-24.37-default or later. SEG-93737/DS-58373
- Anti-Malware would sometimes restart before fully loading a new driver, causing the AM engine to be offline. DS-58475

Deep Security Agent 20.0.0-1559 (20 LTS Update 2020-12-07)

Release date: December 07, 2020

Build number: 20.0.0-1559

New features

TLS Directionality: The manager heartbeat port can now act as both a TLS client and TLS server. Future agents will connect as TLS clients, not TLS servers. This resolves issues with agent-initiated connections through a proxy or firewall that requires TLS sessions to be initiated in the same direction as the TCP layer of the connection.

Enhancements

- Improved Deep Security Relay's performance by only checking packages that have been modified. DS-55527
- Improved Deep Security Agent to better support Activity Monitoring on Trend Micro Cloud One - Workload Security. For more information, see [Enable Activity Monitoring](#). DS-55230
- Enhanced memory usage to improve performance. DS-53012
- Anti-Malware on-demand scans did not function as expected. DS-58346

Resolved issues

- Deep Security Agent didn't detect Secure Boot state correctly. SEG-89042/03730368 /DS-57014
- The error "scheduling while atomic" occurred because the dsa_filter caused kernel panic. DS-56514
- Anti-Malware events didn't include file hashes in certain scenarios. SEG-91779/SF03818756/DS-57453
- The Anti-Malware driver showed warning messages during the initialization. SEG-92204/03784490/DS-57605
- After upgrading to Deep Security Agent 20.0.0-1194, the "Intrusion Prevention Rules Failed to Compile" and "Security Update Failed" errors sometimes incorrectly occurred. SEG-90503/03789013/DS-56904
- When Anti-Malware real-time scans were enabled, Rancher Kubernetes pods sometimes couldn't be terminated gracefully. SEG-87824/SF03695639/DS-58220
- When Integrity Monitoring was enabled, a high amount of CPU was used. SEG-88619/03720485/DS-56613
- Application Control events occurred multiple times for the same incident. SEG-86213/SF03620055/DS-57298
- Security updates were not automatically performed on new machines. SEG-91484/SF03828068/DS-57688

Notice

In this agent update there is a change to how the validation of the TLS certificate used for agent-manager communication is implemented. If you see the following warning during agent activation:

```
[Warning/2] | SSLVerifyCallback() - verify error 20: unable to get local issuer certificate
```

The most likely root cause is that agent cannot validate the certificate being presented to it by the manager. Pinning a trusted certificate is optional, so you can ignore this error if it doesn't apply to you. However, if you'd like to use a trusted certificate, follow the steps in ["Import a Deep Security Manager certificate chain issued by a public CA" on page 1569](#) before activating the Deep Security Agent.

Deep Security Agent 20.0.0-1337 (20 LTS Update 2020-10-28)

Release date: October 28, 2020

Build number: 20.0.0-1337

Resolved issues

- When Anti-Malware real-time scans were enabled in Linux, sometimes the system crashed because of a compatibility issue with third-party security software. SF03700563/SEG-88135/DS-54799
- Secure boot appeared active when it was not. SEG-85550/DS-55052

Deep Security Agent 20.0.0-1304 (20 LTS Update 2020-10-21)

Release date: October 21, 2020

Build number: 20.0.0-1304

Enhancements

- Updated the Integrity Monitoring scan completion time in Deep Security Manager events to display in seconds with a thousands separator. DS-54680

Resolved issues

- For agentless protected VMs, the settings under **Policies > Intrusion Prevention > General > Recommendation** were greyed out. DS-56665
 - When "Serve Application Control rulesets from relays" was enabled, unnecessary relay error events occurred. DS-50905
 - Real-time Anti-Malware with filesystem hooking enabled did not work on older kernel versions. SEG-82411/DS-54271
 - Deep Security Manager reported a security update timeout because Deep Security Agent received exceptions at security updates. SEG-82072/DS-54720
 - Deep Security Manager sometimes showed the incorrect Log Inspection status. SEG-77081/DS-54719
-

- The `dsa_query` command didn't display Anti-Malware patterns correctly. DS-55389
- The Anti-Malware driver did not check compatibility before loading into the kernel. SEG-88135

Action required: Customers participating in the Trend Micro XDR Activity Monitoring preview for Workload Security

This Deep Security Agent release includes required updates for the Trend Micro XDR Activity Monitoring preview. If you are currently participating in the preview, you must upgrade to Deep Security Agent 20.0.0-1304 or later by November 16, 2020. If you do not upgrade to Deep Security Agent 20.0.0-1304 or later, Activity Monitoring data will stop being collected on November 16, 2020. For more information about XDR and Activity Monitoring, see [Integrate Workload Security with XDR](#).

Note: Deep Security Agent 20.0.0-1304 or later uses a new network connection to send Activity Monitoring data to Trend Micro. The connection details can be found in [Enable Activity Monitoring](#). Ensure that agent traffic to this destination is allowed so Activity Monitoring data can be sent to Trend Micro.

Deep Security Agent 20.0.0-1194 (20 LTS Update 2020-10-05)

Release date: October 5, 2020

Build number: 20.0.0-1194

New features

Improved performance for real-time Anti-Malware scanning on Linux: Real-time Anti-Malware scans have been improved for Deep Security Agent on Linux, resulting in increased response time, faster processing, and reduced CPU usage. Previously, all files were scanned during read/write. Now, Anti-Malware scanning is more efficient and file scanning during write is deferred (the file is added to a queue and scanned in the background).

Differentiated platforms: Deep Security Manager can now distinguish between Red Hat and CentOS platforms and operations. DS-52682

Continued network scans: After migrating guest VMs to another ESXi host in the same cluster using vMotion, the Deep Security Virtual Appliance's network scans now continue where they left off, without delay. This feature only applies if you are using NSX-T Data Center and guest machines are using a policy without network feature overrides. DS-50482

Enhancements

- Real-time Integrity Monitoring explicitly matches the directory specified in the base directory. Previously, it matched all paths that started with the base directory. DS-52692
- Integrity Monitoring detects changes to the "setuid" and "setgid" attributes for Linux and Unix platforms. DS-52061
- Ceph is now excluded from file system kernel hooking to prevent kernel panic. SEG-75664/SF03131718/DS-50298
- Recommendation Scans and Integrity Monitoring are now enabled for NSX-T environments. DS-50478
- Extended the scope of the "If a computer with the same name already exists" setting on **Administration > System Settings > Agents** to apply to existing unactivated computers. Previously, it only applied to existing activated computers. DS-51800

Resolved issues

- Secure boot appeared active when it was not. DS-55052
 - Deep Security Agent could not install any plugins with UEFI Secure Boot enabled. DS-54041
 - After upgrading the Deep Security Agent, the "Sending Application Control Ruleset Failed" error sometimes occurred. DS-49828
 - The Anti-Malware engine on Deep Security Virtual Appliance went offline when the signer field in the Census server reply was empty. DS-49807
 - Anti-Malware directory exclusion with wildcards didn't match subdirectories correctly. DS-50245
 - Deep Security Agent on Linux would sometimes crash. SEG-76460/SF03218198/DS-50852
-

- Deep Security Agent reported incorrect network interface information. SEG-77161/DS-51397
- The Deep Security Virtual appliance did not detect the EICAR test file. SEG-71955/SF02955546/DS-49387
- Application Control did not include scripts with the extension ".bash" in the inventory. This resulted in these scripts being blocking in lock down mode. DS-50696
- The Anti-Malware driver caused a system hang on Linux platforms where autofs was used. DS-51926
- When Integrity Monitoring was enabled, the owner of a file was incorrectly changed to a user that did not exist. DS-52058
- There was an upgrade issue with Deep Security Agent which would sometimes prevent the agent from going online if Integrity Monitoring or Log Inspection were enabled. DS-50672
- Kernel Panic occurred when Web Reputation, Firewall, or Intrusion Prevention were enabled. SEG-80201/DSSEG-5846/DS-52975
- When Anti-Malware real-time scans were enabled in Linux, sometimes the system crashed because buffers from procs were not validated. SEG-80183/DS-53204
- When a re-transmission packet with new packets was sent, it sometimes produced an "Unsupported SSL Version" Intrusion Prevention event. SEG-73893/DSSEG-5866/DS-53144
- When Deep Security real-time Anti-Malware was enabled on a Linux system, it caused a high amount of CPU usage. SEG-75739/DS-52976

Security updates

Security updates are included in this release. For more information about how Trend Micro protects against vulnerabilities, visit [Vulnerability Response](#). Note that in line with responsible disclosure practices, CVE details will only be made available for select security updates once patches have been made available for all impacted releases. VRTS-3704/DS-41233

Highest CVSS score: 4.4

Highest severity: Medium

Deep Security Agent 20 (long-term support release)

Release date: July 30, 2020

Build number: 20.0.0.877

New features

Enhanced platform support

- Ubuntu 20.04 (64-bit)
- Cloud Linux 8 (64-bit)
- Debian Linux 10 (64-bit)
- Oracle Linux 8 (64-bit)
- SUSE Linux Enterprise Server 15 (64-bit)
- Red Hat Enterprise Linux 8 (64-bit)
- CentOS 8 (64-bit)

SystemD support: SystemD is a Linux service manager that allows services to declare dependencies, which can enforce load and unload sequences of kernel modules and other services. See ["Linux systemd support" on page 351](#) for information about which platforms are supported. DS-37395

Secure Boot support: Deep Security Agent supports additional Linux operating systems with Secure Boot enabled. For details, see ["Linux Secure Boot support" on page 356](#).

Improved security

Agent integrity check: Deep Security verifies your signature on the Deep Security Agent to ensure that the software files have not changed since the time of signing.

Protect VMs in NSX-T environments: The latest VMware Service Insertion and Guest Introspection technologies have been integrated. This enables you to protect your guest VMs using Intrusion Prevention, Web Reputation, Firewall, Integrity Monitoring and recommendation scans on NSX-T hosts with agentless protection.

Seamless network protection: Deep Security Manager now sends guest VMs' network configuration to all Deep Security Virtual Appliances that are under the same cluster. The effect is that the appliances can now maintain the protection of guest machines that

use the network features during and after a vMotion migration from one ESXi host to another under the same cluster. This feature only applies to NSX-T environments where the guest machine is using an assigned policy without network features overrides.

SELinux Support: Security-Enhanced Linux (SELinux) enforcing mode is supported on Red Hat Enterprise Linux 7 and Red Hat Enterprise Linux 8. Deep Security Agent is compatible with the default SELinux policies.

Note: Anti-Malware software such as `ds_agent` is required to run in an unconfined domain in order to protect the system. Any additional SELinux policy customization or configuration might be block blocked or fail because of `ds_agent`.

SSL improvements: Deep Security supports handshake `hello_request` (rfc5246) and Extension `encrypt_then_mac` (rfc7366) in SSL inspection.

Continuous Anti-Malware protection: Deep Security Manager now sends guest VMs' Anti-Malware real-time configuration to all Deep Security Virtual Appliances that are under the same cluster. The effect is that the appliances can now maintain the protection of guest machines that use the Anti-Malware real-time feature during and after a vMotion migration from one ESXi host to another under the same cluster. This feature only applies to NSX-T environments.

Improved management and quality

Automate the upgrade of agents in your environment: Deep Security gives you the flexibility to decide if new agents, when activated, should be upgraded to a newer version if one is available. This can be particularly useful in cases where application teams are using older golden images containing a version of the agent that is out of date. Simply enable upgrade on activation, define the lineup of agents you want to use in your environment using Agent Version Control, and as older agents come online and activate they are automatically upgraded for you.

NSX-T Network Throughput improvement: By introducing the Data Plane Development Kit (DPDK), the network throughput has been made three times faster when compared with prior technology.

Upgrade to supported paths: The Upgrade on activation feature only upgrades the agent on the computer from the last two major releases. If the agent does not meet the criteria, you must upgrade the agent manually to a release within the last two major

releases. Then the Upgrade on activation feature detects the newer version and complete the upgrade to the designated release.

Protection for AWS accounts with incorrect credentials: In the past, if your credentials were entered incorrectly for AWS accounts in Deep Security, the agent failed to activate. This might have occurred because the credentials were entered incorrectly or because, over time, the credentials changed without a corresponding update on Deep Security. To help ensure protection remains in place in this situation, which in many cases is a simple configuration error, the computer is now created outside of the account and the agent is allowed to activate.

Instance Metadata Service Version 2 (IMDSv2) support: IMDSv2 is supported in this release. For details, see ["How does Deep Security Agent use the Amazon Instance Metadata Service?" on page 1911](#)

Actionable recommendations for scan failures: The Deep Security Agent provides actionable information about why a scheduled malware scan has been cancelled, and the recommended actions that should be taken to remedy the failure. For more information, see ["Anti-Malware scan failures and cancellations" on page 1133](#).

Improved process exceptions: The process exception experience has been improved in the following ways:

- Information about why process exclusion items are not functioning correctly is provided, enabling you to troubleshoot the issue and know which actions to take to resolve it.
- The process exception configuration workflow has been improved to make it more robust.

Enhancements

- Integrity Monitoring detects changes to the "setuid" and "setgid" attributes for Linux and Unix platforms.
 - Improved the heartbeat handling for Amazon WorkSpaces deployments when the workspace sync feature is not turned on for the matching AWS connector.
 - Extended the scope of the **If a computer with the same name already exists** setting on **Administration > System Settings > Agents** to apply to existing unactivated computers. Previously, it only applied to existing activated computers.
-

- Improved the Deep Security Agent activation experience in the following ways:
 - Enhanced the agent-initiated activation experience by displaying the activation status (for example, a success message or a message that explains a newer Deep Security Manager version is required) on Deep Security Manager.
- After migrating guest VMs to another ESXi host in the same cluster using vMotion, the Deep Security Virtual Appliance's Anti-Malware real-time scans now continue where they left off, without delay. This feature only applies to NSX-T environments.
- Increased the scan engine's URI path length limitation.
- Added the ability for Deep Security Agent Anti-Malware to scan compressed files no matter their data types when IntelliScan is disabled.
- Enhanced Linux real-time Anti-Malware performance when executing a Docker pull command.
- Improved the time it takes to auto-activate guest VMs protected by the Deep Security Virtual Appliance in an NSX-T environment.

Note: This feature requires Deep Security Manager FR 2019-12-12 or newer releases.

- Streamlined event management for improved agent performance.
- Added the ability to enable or disable Common Scan Cache for each agent through a CLI command.
- Enhanced the Malware Scan Failure event description to indicate the possible reason.
- Enhanced the Anti-Malware kernel level exclusion on Linux. File events coming from remote file systems won't be handled by Deep Security Agent anymore when Network Directory Scan is disabled.
- Added the ability to retrieve process and container information for Intrusion Prevention events, including process name, container ID, container name, image name, image digest and pod ID.

Resolved issues

- When Anti-Malware real-time scans were enabled in Linux, sometimes the system crashed because buffers from procsfs were not validated. SEG-80183/DS-53204
- When Deep Security real-time Anti-Malware was enabled in Linux, it caused a high amount of CPU system usage. SEG-75739/SF03036857/DS-52976
- Ceph caused kernel panic. SEG-75664/SF03131718/DS-50298
- Deep Security Agent sometimes crashed. SEG-76460/SF03218198/DS-50852
- Deep Security Agent reported incorrect network interface information. SEG-77161/DS-51397
- The Deep Security Virtual Appliance did not detect an Eicar file. SEG-71955/SF02955546/DS-49387
- Application Control did not include scripts with the extension ".bash" in the inventory. This resulted in these scripts being blocked in lock down mode. SEG-73174/DS-50696
- Deep Security Virtual Appliance sometimes went offline. SEG-53294/DS-46728
- The interface isolation feature was still on when Firewall was turned off. SEG-32926/DS-27099
- In a Red Hat Enterprise Linux 5 or 6 or a CentOS 5 or 6 environment, Integrity Monitoring events related to the following rule were displayed even if users or groups were not created or deleted: 1008720 - Users and Groups - Create and Delete Activity. SEG-22509/DS-25250
- Integrity Monitoring events showed an incorrect file path with Unicode encoding. SEG-45239/DS-33911
- Anti-Malware events displayed a blank file path with invalid Unicode encoding. SEG-46912/DS-34011
- Certain data structures in the Deep Security Agent packet engine were cleaned up prematurely, leading to a kernel panic and system crash. SF01423970/SEG-43481/DS-34436
- Kernel panic occurred when dsa_filter.ko was obtaining network device's information. SEG-50480/DS-35192

- An SAP system with Java running in a Linux environment failed to start when Deep Security Scanner returned an error code without an error message. SF01339187/SEG-38497/SEG-33163/DS-31330
- Kernel panic occurred because of redirfs. SF01137463/SEG-34751/DS-32182
- Deep Security Anti-Malware caused the fusermount process to fail when mounting the filesystem. SF01531697/SEG-43146/DS-32753
- Deep Security Agent's Intrusion Prevention module silently dropped zero payload UDP packets. SEG-39711/DS-32799
- For Web Reputation, Deep Security Agent sent the incorrect credentials to the proxy, which returned HTTP 407. SF01704358/SEG-45004/DS-32077
- Deep Security Agent GSCH driver had an issue with another third-party file system. SF01248702/SEG-44565/DS-33155)
- The Environment Variable Overrides for Deep Security Anti-Malware did not work in Linux. SEG-43362/DS-31328
- Deep Security Agent process potentially crashed when the detailed logging of SSL message was enabled and outputted. SF01745654/SEG-45832/DS-33007
- When multiple Smart Protection Servers were configured, the Deep Security Agent process would sometimes crash due to an invalid sps_index. SF01415702/SEG-42919/DS-33008
- The Send Policy action failed because of a GetDockerVersion error in Deep Security Agent. SF1939658/SEG-49191/DS-34222
- Deep Security Agent sent invalid JSON objects in response to Deep Security Manager, which caused errors in Deep Security Manager's log file. SF01919585/SEG-48728/DS-34022
- The ds_agent process would sometimes crash under certain conditions when Integrity Monitoring was enabled. SEG-50728/DS-35446
- Deep Security Agent failed to install on Ubuntu 18.04. SF01593513/SEG-43300/DS-37359
- The Deep Security Agent network engine crashed because the working packet object was deleted accidentally. SF01526046/SF02159742/SEG-55453/DS-38812
- Unicode user names could not be displayed in real-time Integrity Monitoring file scan events. SF02187371/SEG-56645/DS-39398

- The agent operating system would sometimes crash when Firewall interface ignores were set. SF01775560/SEG-49866/DS-39339
 - Deep Security Agent did not add Python extension module (PYD) files to the inventory of Application Control. SF01804378/SEG-47425/DS-33690
 - Too many file open events were being processed in user mode, resulting in high cpu usage. SF02179544/SEG-55745/DS-39638
 - The "mq_getattr: Bad file descriptor" error occurred while accessing the message queue when Deep Security real-time Anti-Malware was enabled. SF02042265/SEG-52088/DS-39890
 - Linux kernel logs were flooded by Deep Security Anti-Malware driver. SF02299406/SEG-57561/DS-41589
 - Non-executable files that were opened with execute permissions resulted in security events and drift that should not have been generated. SF01780211/SEG-46616/DSSEG-3607
 - High CPU use occurred when Application Control was enabled and the host application was creating a high volume of non-executable files. SF02179544/SEG-55745/DS-41142
 - Deep Security Agent real-time Anti-Malware scans didn't work with Debian 10 64-bit.
 - When a guest VM was migrated between ESXi hosts frequently (using vMotion), sometimes the VM couldn't save the state file. This caused the guest to lose the protection of the Deep Security Virtual Appliance for several minutes after migration, until the VM was reactivated by Deep Security Manager automatically under the new ESXi server. DSSEG-4341/DS-38221
 - When uninstalling Deep Security Agent in Linux, the uninstall log included a typo. DSSEG-4139/DS-34504
 - Deep Security Anti-Malware detected sample malware files but did not automatically delete them. SF02230778/SEG-55891/DS-40687
 - When the Deep Security Agent connected through a proxy to the Deep Security Manager on Deep Security as a Service, Identified Files could not be deleted. SF01979829/SEG-51013/DS-37252
 - After applying rule 1006540, "Enable X-Forwarded-For HTTP Header Logging", Deep Security would extract the X-Forwarded-For header for Intrusion Prevention
-

events correctly. However, a URL intrusion like "Invalid Traversal" would be detected in the HTTP request string before the header was parsed. The Intrusion Prevention engine has been enhanced to search X-Forwarded-For header after the header is parsed. SEG-60728/DSSEG-5094

- Deep Security Agent sent invalid JSON objects in response to Deep Security Manager, which caused errors in Deep Security Manager's log file. SF01919585/SEG-48728/DSSEG-4995

Security updates

Security updates are included in this release. For more information about how Trend Micro protects against vulnerabilities, visit [Vulnerability Response](#). Note that in line with responsible disclosure practices, CVE details will only be made available for select security updates once patches have been made available for all impacted releases. VRTS-3704/VRTS-3176

Highest CVSS Score: 7.8

Highest Severity: High

- Updated NGINX to 1.16.1 (DSSEG-4600)
- Updated to curl 7.67.0.
- Updated to openssl-1.0.2t.
- Updated JRE to the latest Java Update (8.0.241/8.43.0.6).

Kernel support

To see which Linux kernels are currently supported, see "[Linux kernel compatibility](#)" on [page 349](#).

To view the Linux kernel support release history, see the [Readme for Trend Micro \(TM\) Deep Security Agent 20.0 for Linux](#).

Known issues

- Autofs is currently not supported for use when real-time Anti-Malware is enabled. If autofs is used with real-time Anti-Malware enabled, some mountpoints are unmounted successfully. SEG-58841

Windows

Deep Security Agent - 20.0.1-7380 (20 LTS Update 2024-04-24)

Release date: April 24, 2024

Build number: 20.0.1-7380

Enhancements

- Deep Security Agent now supports Trend Vision One Service Gateway exclusions. This is only supported for Trend Cloud One - Endpoint & Workload Security users at this time. V1E-17754
- Deep Security Agent can have its proxy configuration set by the Trend Vision One Proxy Manager. V1E-14557
- Deep Security Agent now supports custom actions "ActiveAction" or "Pass" for the Process Memory Scan. This is only supported for Trend Cloud One - Endpoint & Workload Security users on Windows platforms at this time. DSA-3621

Resolved issues

- Deep Security Agents running in cloud environments sometimes could not be activated for Trend Cloud One - Endpoint & Workload Security. DSA-4861
- When SAP Scanner was enabled, system events for "SAP: Anti-Malware module is not ready" or "SAP: Virus Scan service is not working correctly" sometimes displayed during Deep Security Agent upgrade. These system event messages were triggered by the restart of Deep Security Agent modules. There was no functional impact. DSA-4603

Deep Security Agent - 20.0.1-4540 (20 LTS Update 2024-03-20)

Release date: March 20, 2024

Build number: 20.0.1-4540

Enhancements

- The SAP Scanner status for Deep Security Agent is now displayed in the console. DSA-3329
- The Deep Security Agent version is now displayed in the SAP Scanner library. SF07483850/PCT-10077/DSA-3304
- Stopping a Deep Security Agent managed by Trend Cloud One - Endpoint & Workload Security now takes less time. DSA-4208
- Anti-Malware events (Events & Reports > Anti-Malware Events) now display the date and time that files or folders were created and modified. SF07199253/PCT-1378/DSA-3578

Resolved issues

- Deep Security Agent incorrectly classified the MIME type of .dwg files generated by AutoCAD, from AutoCAD 2004 to AutoCAD 2024. SF07027236/SEG-186079/PCT-5797/DSA-2901

Deep Security Agent - 20.0.1-3180 (20 LTS Update 2024-02-29)

Release date: February 29, 2024

Build number: 20.0.1-3180

New features

- Anti-Malware now supports Advanced Process Memory Scan by default for Trend Cloud One customers. DSA-4242

Enhancements

- Deep Security Scanner (SAP) now reports files containing Microsoft Office Macros as Active Content, while previously they were identified as Malware. PCT-5979/DSA-3911

Resolved issues

- Migration of agents from on-premise Deep Security Manager to Trend Cloud One - Endpoint & Workload Security using Trend Vision One Service Gateway failed. This issue could also occur when migrating using other proxy services. PCT-16649/DSA-4144
- Remote Desktop Services on Windows Server 2008 R2 was blocked by the TLS inspection process (tm_netagent). PCT-12049/PCT-12172/PCT-13878/DSA-3944
- Behavior Monitoring exclusions sometimes failed to apply because they were case sensitive. PCT-16168/PCT-16005/PCT-16476/CTSKA-27/DSA-4116
- The expected MIME type for `.msg` files by the Deep Security Agent SAP Scanner was incorrect. PCT-5797/DSA-4050
- Enabling Intrusion Prevention or Web Reputation Service in Deep Security Agent sometimes resulted in a TLS inspection process (tm_netagent) error log rotation issue. DSA-3965
- When a password is required for a local override, the password was checked after the Deep Security Agent self-protection was locally disabled. PCT-10861/DSA-3293
- Uninstalling Deep Security Agent did not remove all folders associated with Deep Security Agent. DSA-2460

Security updates

Security updates are included in this release. For more information about how Trend Micro protects against vulnerabilities, visit [Vulnerability Response](#). Note that in line with responsible disclosure practices, CVE details will only be made available for select security updates once patches have been made available for all impacted releases. VRTS-11708/DSA-3702

Highest CVSS score: 7.8

Highest severity: High

Known issues

- The Application Control Trust Entities "block by target" trust rule sometimes does not work properly when running a copy of an executable file. PCT-11105/DSA-

3324

Deep Security Agent - 20.0.1-700 (20 LTS Update 2024-04-17)

Release date: April 17, 2024

Build number: 20.0.1-700

Enhancements

- Updated Deep Security Agent to improve the priority for configurations using a proxy. This is only supported for Trend Cloud One - Endpoint & Workload Security customers on Windows x64 platforms at this time. DSA-4817/PCT-21750

Known issues

- Updating to Deep Security Agent 20.0.1.700 fails on some 20.0.0 versions when using Deep Security Relay. For more details, see [Failed remote upgrade of self-deployed Workload Security relay from 20.0.0-3445 or later to version revision 20.0.1](#). DSA-3317
- Enabling Intrusion Prevention or Web Reputation Service in Deep Security Agent might result in a TLS inspection process (tm_netagent) error log rotation issue. For more details, see [TLS inspection process error log rotation problem in Deep Security](#). DSA-3773

Deep Security Agent - 20.0.1-690 (20 LTS Update 2024-01-17)

Release date: January 17, 2024

Build number: 20.0.1-690

New features

Command line scan: Deep Security Agent now supports on-demand scans triggered using `dsa_scan` from a command line interface.

This is currently only available to Trend Cloud One - Endpoint & Workload Security customers. For more information, see [Command-line basics](#). V1E-6993

Enhancements

- From 2024 onward, Deep Security Agent versioning is being revised from 20.0.0 to 20.0.1. This requires Deep Security Manager 20.0.883 or later. DSA-3584

For details, see [Platform support updates for Deep Security Agent \(DSA\) version revision in January 2024 Update Release](#).

Resolved issues

- Deep Security Agent was sometimes unable to connect to the local Smart Protection Server. DSA-3564
- Deep Security Agent could have memory leaks on some systems while trying to route to Domain Controllers. DSA-3266
- Deep Security Agent sometimes froze at launch if Windows APIs were verifying digital signatures for portable executable (PE) files. DSA-3626
- When FIPS mode was disabled, Deep Security Agent used the OpenSSL configuration specified by the system environment variables rather than the config specified by the agent. PCT-4914/DSA-2651/DSA-2737/DSA-2738

Security updates

Security updates are included in this release. For more information about how Trend Micro protects against vulnerabilities, visit [Vulnerability Response](#). Note that in line with responsible disclosure practices, CVE details will only be made available for select security updates once patches have been made available for all impacted releases. V1E-10952

Highest CVSS score: 9.8

Highest severity: Critical

Known issues

- Updating to Deep Security Agent 20.0.1-690 from some 20.0.0 versions sometimes fails when using Deep Security Relay on Trend Cloud One - Endpoint & Workload Security. For details, see [Failed remote upgrade of self-deployed Workload Security relay from 20.0.0-3445 or later to version revision 20.0.1](#) DSA-

3317

- Enabling Intrusion Prevention or Web Reputation Service in Deep Security Agent might result in a TLS inspection process (`tm_netagent`) error log rotation issue. For details, see [TLS inspection process error log rotation problem in Deep Security](#). DSA-3773

Deep Security Agent - 20.0.0-8438 (20 LTS Update 2023-12-12)

Release date: December 12, 2023

Build number: 20.0.0-8438

New features

Windows 11, version 23H2 support: Deep Security Agent 20.0.0-8438 or later support Windows 11, version 23H2. DSA-2255

Enhancements

- Remove some file types from the scanning list to avoid high CPU and disk consumption. SF07099651/SEG-188688/DSA-2010
- Agent self-protection now protects the Advanced TLS Traffic Inspection process (`tm_netagent`) preventing local users with administrator privileges from stopping it. DSA-1042/DSA-1043

Resolved issues

- When using a local Smart Protection Server and a configured proxy, Web Reputation Service would sometimes improperly send traffic through the proxy. Web Reputation Service now sends queries to the local Smart Protection Server directly. DSA-2981
- Anti-Malware scan mode would sometimes not match the policy configuration. SF07117203/SEG-191043/PCT-7856/DSA-2561
- A memory leak would occur when loading large Suspicious Object lists. SF06904914/SEG-182231/DSA-1370

Security updates

Security updates are included in this release. For more information about how Trend Micro protects against vulnerabilities, visit [Vulnerability Response](#). Note that in line with responsible disclosure practices, CVE details will only be made available for select security updates once patches have been made available for all impacted releases.

VRTS-11015/DSA-2156

Highest CVSS score: 7.8

Highest severity: High

Known issues

- Enabling Intrusion Prevention or Web Reputation Service in Deep Security Agent might result in a TLS inspection process (`tm_netagent`) error log rotation issue. For details, see [TLS inspection process error log rotation problem in Deep Security](#). DSA-3773
- Deep Security Agent is sometimes unable to connect to the local Smart Protection Server. This issue is fixed in 20.0.1-690. For details, see [Deep Security Agent \(DSA\) connection issues with Smart Protection Server \(SPS\) when using proxy](#). DSA-3564

Deep Security Agent - 20.0.0-8268 (20 LTS Update 2023-11-21)

Release date: November 21, 2023

Build number: 20.0.0-8268

Resolved issues

- Deep Security Anti-Malware sometimes did not function as expected after the system had resumed from sleep mode (S0 low-power idle mode of the working state, also known as modern standby). SF07326571/PCT-5476/DSA-2485
- Deep Security Agent incorrectly classified MIME type of `.xml` files generated by Microsoft Word, Excel, PowerPoint, as well as `.dwg` files generated by AutoCAD and R2000. SF07027236/SEG-186079/DSA-2202

Known issues

- Enabling Intrusion Prevention or Web Reputation Service in Deep Security Agent might result in a TLS inspection process (`tm_netagent`) error log rotation issue. For details, see [TLS inspection process error log rotation problem in Deep Security](#). DSA-3773

Deep Security Agent - 20.0.0-8137 (20 LTS Update 2023-10-26)

Release date: October 26, 2023

Build number: 20.0.0-8137

New features

- **Process Memory Scan:** Anti-Malware manual and scheduled scans now support the process memory scan which scans the memory of running processes. This requires Deep Security Manager 20.0.844 or later.

Resolved issues

- When Intrusion Prevention System was enabled on a machine with Windows Network Load Balancing (NLB) installed and Unicast Mode configured, Network Load Balancing performance was sometimes affected. SF06426122/SEG-169878/DSSEG-7852
- When agent self-protection was enabled for Deep Security Agent 20.0.0-7719, access violation errors would sometimes appear in the Windows System Log. DSA-1962

Known issues

- Enabling Intrusion Prevention or Web Reputation Service in Deep Security Agent might result in a TLS inspection process (`tm_netagent`) error log rotation issue. For details, see [TLS inspection process error log rotation problem in Deep Security](#). DSA-3773

Deep Security Agent - 20.0.0-7943 (20 LTS Update 2023-09-26)

Release date: September 26, 2023

Build number: 20.0.0-7943

Enhancements

- In order to display agent pattern updates properly, Deep Security Agent 20.0.0-7943 or later requires Deep Security Manager 20.0.759+. For more information, see [Incompatible Agent / Appliance Version error in Deep Security Agent 20.0.0-7943](#). SEG-190866/SEG-191017/DSA-1531
- New commands exist to get proxy information from the command line:
`dsa_query -c GetProxyInfo`
`dsa_query -c GetProxyInfo details=true`. DSA-864
- Web Reputation Service now supports the "Trend Micro Toolbar for Enterprise" browser extension for Microsoft Edge on Windows 10 (64-bit), Windows 11, Windows Server 2016, Windows Server 2019 and Windows Server 2022. DSA-1565

Resolved issues

- When Log Inspection was enabled, Deep Security Agent sometimes crashed on Windows Server 2019 systems. DS-77766

Deep Security Agent - 20.0.0-7719 (20 LTS Update 2023-08-29)

Release date: August 29, 2023

Build number: 20.0.0-7719

New features

New language support: Deep Security Agent now supports Polish and Czech.

Enhancements

- Deep Security Agent no longer updates the Smart Scan agent pattern when Smart Scan is disabled, saving network bandwidth. SEG-186625/DSA-1063

- Deep Security Agent now downloads fewer incremental pattern updates, saving network bandwidth. Note that agents configured as a Deep Security Relay still download all pattern updates. DSA-1000
- The blocking page Web Reputation Service redirects users when they try to access a blocked URL can now be viewed in Czech or Polish. DSA-444
- Deep Security Agent now triggers a security update automatically when the Anti-Malware Solution Platform (AMSP) service is ready. Previously, security updates could fail if triggered before the AMSP was ready, causing "Anti-Malware Engine Offline" and "Pattern Update on Agents/Appliances Failed" errors. DSA-1020
- Activity Monitoring now includes hypersensitive mode to provide improved MITRE coverage. DS-76971/DS-76972/DSA-797

Resolved issues

- Stopping the Deep Security Agent service (ds_agent) took longer than usual on some systems. SEG-187365/DSA-1212
- Deep Security Agent sometimes performed security updates even if none were scheduled. SEG-187449/DSA-1064
- When Anti-Malware was enabled, Deep Security Agent impacted the performance of some third-party applications. SEG-182065/DSA-790
- Deep Security Agent caused high CPU usage on some systems. SEG-185563/DSA-756
- Device Control blocked Windows Server Storage Area Network (SAN) drives that should have been allowed. SEG-178278/V1E-3895
- Network drivers failed to bind to the network interface automatically on some Azure VMs. DSA-1040

Security updates

Security updates are included in this release. For more information about how Trend Micro protects against vulnerabilities, visit [Vulnerability Response](#). Note that in line with responsible disclosure practices, CVE details will only be made available for select security updates once patches have been made available for all impacted releases. VRTS-7976/DSA-1386

Highest CVSS score: 7.8

Highest severity: High

Deep Security Agent - 20.0.0-7476 (20 LTS Update 2023-07-25)

Release date: July 25, 2023

Build number: 20.0.0-7476

New features

Deep Security Agent Right-Click Scan: Deep Security Agent now allows users to trigger a manual scan from Windows File Explorer by right-clicking a file or folder and selecting **Scan**. Note that this feature is only available to Trend Vision One Endpoint users and Trend Cloud One - Endpoint & Workload users at this time.

Enhancements

- If anti-malware is offline because AMSP service was not installed correctly, Deep Security Agent now tries to reinstall AMSP when the agent service launches. DSSEG-7903/SEG-181443
- Updated the dsa-connect service to improve CPU performance. C1WS-12970
- Updated Deep Security Agent to support the Notifier Anti-Malware Protected Process Light (AM-PPL) service for Windows 10 desktop platforms. This requires Deep Security Manager 20.0.789 - 20.0.833. DS-77160
- Improved Advanced TLS Traffic Inspection coverage for Windows Server 2012 R2, 2016, and 2019. SEG-182585/DSA-583

Resolved issues

- Smart Protection Servers would sometimes lose connectivity with Web Reputation Service. SF06423462/SEG-166651/DSSEG-7858
 - The system sometimes crashed when Intrusion Prevention was enabled. SF06983729/SEG-184423/DSSEG-7907
 - Deep Security Agent upgrades triggered from the Deep Security Manager console would fail on some system configurations, returning MSI error code 1601: Windows installer is not accessible. SEG-177789/DS-78084
-

- Deep Security Agent sometimes reported that the network module was disabled (Event ID 1013, Trend Micro LightWeight Driver failed to bind on all network interfaces) even if the module was enabled. SEG-184701/SEG-182649/DSA-686
- Updated Deep Security Agent to support systems using Dell MAC Address Passthrough. SEG-177651/DSA-455

Deep Security Agent - 20.0.0-7303 (20 LTS Update 2023-06-28)

Release date: June 28, 2023

Build number: 20.0.0-7303

Enhancements

- Deep Security Agent now supports IPv6 addresses using either CIDR or double colon notation, such as fe80:0:0:0:0:0:1/24 or fe80::01. SF04849178/SEG-122076/DS-67280
- Activity Monitoring events now display the FQDN instead of the hostname. SF06709374/SEG-179186/C1WS-14644
- Web Reputation Service now automatically monitor the ports used by the [OS proxy](#) configuration. DS-77233
- When a specific process is sending backup packets through an unencrypted connection, Intrusion Prevention optimizes the scan flow to reduce CPU impact. SF06456142/SEG-166877/DS-76500

Resolved issues

- The Windows Malicious Software Removal Tool (MSRT) installation could fail while Application Control is in maintenance mode. SF06446534/SEG-172729/DS-77094
 - Intrusion Prevention (IPS) might not read the correct payload value, which can result in rule malfunctions. DS-74647
 - The Deep Security Agent would report "dsa-connect has not provided status" on every heartbeat, even when Endpoint Sensor was not in use. C1WS-14696
 - The Deep Security Agent upgrade would fail when specific features were enabled. SF06794868/SEG-177789/DS-78008
-

- Deep Security Agent sometimes crashed when it was unable to connect to Deep Security Manager using a proxy. DS-77786
- When Application Control was enabled, MSI file installations failed on some versions of Windows. SF06509811/SEG-170485/DS-76906
- Deep Security Relay 20.0.0-7119 failed to provide security and software updates when using the [improved Relay](#). SF06935222/SEG-183184/DS-78201
- Some MQTT messages would be sent repeatedly and cause dsa-connect to get stuck in a shutdown loop. DS-76709

Deep Security Agent - 20.0.0-7119 (20 LTS Update 2023-05-29)

Release date: May 29, 2023

Build number: 20.0.0-7119

Enhancements

- Updated Deep Security Agent to reduce data usage when generating Activity Monitoring events or when operating while integrated with Trend Micro Vision One. DS-77622
- When Application Control is enabled, MSI file installations fail on some systems. SF06509811/SEG-170485/DS-76906
- Agent self-protection now secures the Advanced TLS inspection process (`ds_nuagent`), preventing local users with administrator privileges from stopping it. DS-74080
- Deep Security Agent 20.0.0-7119 or later now supports FIPS mode for the `dsa-connect` service for Workload Security customers on Windows platforms that support FIPS mode as detailed here: [Supported features by platform](#). C1WS-7467

Resolved issues

- Deep Security Agent only reported a single Anti-Malware event for an infected compressed file, even if it contained multiple infected files. DS-76339
- After replacing a connection, Deep Security Agent reported metrics as though it was still connected to the old connection for up to 4 minutes. DS-77453

- If Advanced TLS traffic inspection was enabled, rebooting the operating system sometimes caused Deep Security Agent to get stuck on the "stopping services" screen. SF06494167/SEG-170082/DS-76880
- The Deep Security Notifier service (`ds_notifier`) caused a memory leak during agent updates on some systems. SF06454240/SEG-167684/DSSEG-7863

Known issues

- Upgrading to Deep Security Agent version 20.0.0-6860, 20.0.0-6690, or 20.0.0-7119 using the Deep Security Manager console sometimes results in upgrade failure. After the upgrade failure, the Deep Security Agent service stops and may show "Agent Offline" from the manager console. For more details, see https://success.trendmicro.com/dcx/s/solution/000293284?language=en_US. SEG-177789, SEG-177748, SEG-178496, SEG-178742, SEG-177423, SEG-178470, SEG-178940, SEG-178956

Deep Security Agent - 20.0.0-6860 (20 LTS Update 2023-04-25)

Release date: April 25, 2023

Build number: 20.0.0-6860

Enhancements

- Updated Deep Security Agent to make the connection timeout for proxy probing configurable by adding a line to `ds_agent.ini`. SF06664116/SEG-173848/DS-77182

Example proxy probing line in `ds_agent.ini` config file:

```
dsa.proxymanager.ProbeTimeoutInSec=120
```

- Made improvements to Deep Security Agent to prevent it incorrectly sending "MQTT Connection Offline" warnings when the connection is online. SEG-171358/C1WS-12979
- Updated Deep Security Agent to improve MQTT connection quality and reduce the occurrence of connection timeouts. DS-76840
- Deep Security Agent installer now prevents the agent from updating if it detects SHA-1 was used to sign the certificate on the agent installer. This prevents the

agent from updating and becoming unresponsive, since Deep Security Agent 20.0.0-6313 and higher requires RSA-2048 and SHA-256. For more information on certificate upgrade, see [Upgrade the Deep Security cryptographic algorithm](#). DS-76499

- Error messages from the Trend Micro Deep Security Notifier now provide more details when the on-demand scans fail. VO-2132

Resolved issues

- Deep Security Agent was unable to load the third-party libraries required to use Remote Shell, File Collection, or Network Isolation on the Windows 2008 platform. DS-75176
- Deep Security Agent would sometimes freeze on system startup, which caused the Windows Service Control Manager service to generate "service hung on starting" events (Event ID 7022). DS-77212
- When Anti-Malware Predictive Machine Learning was enabled, file operations initiated by Powershell sometimes encountered sharing violations. SF05904706/SEG-150738/DSSEG-7695
- When Web Reputation Service was enabled, Deep Security Agent caused some systems to shutdown unexpectedly. SF06680505/SEG-174730/DSSEG-7866
- Deep Security Agent sometimes reported the network driver status incorrectly after the driver had restarted. C1WS-12896

Security updates

Security updates are included in this release. For more information about how Trend Micro protects against vulnerabilities, visit [Vulnerability Response](#). Note that in line with responsible disclosure practices, CVE details will only be made available for select security updates once patches have been made available for all impacted releases. VRTS-8320/DSSEG-7865

Highest CVSS score: 2.9

Highest severity: Low

Deep Security Agent - 20.0.0-6690 (20 LTS Update 2023-03-29)

Release date: March 29, 2023

Build number: 20.0.0-6690

New features

Service Gateway: Deep Security Agent 20.0.0-6690 or later with Deep Security Manager 20.0.741 or later now supports the Service Gateway feature, providing forward proxy functionality.

Enhancements

- Deep Security Agent installation now performs a pre-check to verify if its operating system meets Azure Code Signing (ACS) requirements. For more information, see [Trend Micro Server and Endpoint Protection Agent Minimum Windows Version Requirements](#). DS-75552
- Application Control now checks the execution of Microsoft Windows Control Panel Applet (.CPL) files. DS-74587
- Application Control now checks the execution of Microsoft Compiled HTML help (.CHM) files. DS-74828
- When an Application Control Trust Entities path rule uses a wildcard without specifying a filename, the wildcard now applies to all files in any directory matching the rule's path. Note that previously, the globstar (**) wildcard would apply to a path rule's directory and subdirectories, as opposed to the single star (*) wildcard which would only match within the path rule's directory. DS-75133
- Web Reputation Service now includes OS platform metadata. DS-75453
- Deep Security Agent 20.0.0-6690 or later now supports the Proxy Manager for Trend Micro Vision One (XDR) Threat Intelligence - User Defined Suspicious Object (UDSO). DS-75365
- Updated Deep Security Agent's logging system to provide additional information and tracing to debug customer issues more efficiently. The agent now generates five (5) log files (`dsa-connect-X.log`) that are 2MB each instead of the agent's previous three 1MB log files. C1WS-9598

The logger supports an on-demand JSON config file (either `dsa-connect.ini` or `dsa-connect.conf`) with the following configurable options:

- Debug: Enable the debug log messages. The default value is false.
- Count: Number of log files to generate. The default value is 5.

- Size: Maximum size of each log file in bytes. The default value is 2097152.

Example config file:

```
{
  "Debug": true,
  "Count": 5,
  "Size": 2097152
}
```

- The Web Reputation Service's Browser Extension now allows Trend Micro Toolbar for Chrome browser to inspect URLs for content scripts in all frames. DS-75387
- Anti-Malware events generated by the SAP Scanner now include file hashes. DS-75648/SEG-165491

Resolved issues

- Deep Security Agent events and module status changes sometimes failed to appear in the console. DS-46344/SEG-67100/SEG-101719/SEG-112311
- When Anti-Malware's "Enable network directory scan" option was enabled (**Computer or Policy > Anti-Malware > General > Real-Time Scan > Malware Scan Configuration > Advanced > Network Directory Scan**), malware was detected but a corresponding event was not recorded in some cases. SF06198579/SEG-160763/DSSEG-7786
- When the Advanced TLS Traffic Inspection "Inspect TLS/SSL traffic" option was set to "No" from the console (**Computer or Policy > Intrusion Prevention > General > Advanced TLS Traffic Inspection**), driver-side SSL packets were sometimes still being processed. DS-76160
- Deep Security Agent's Intrusion Prevention System sometimes failed to block "TCP Congestion Flags" properly. DS-76182
- When Anti-Malware Smart Scan was enabled, an IPC connectivity issue caused some systems to crash. SEG-169132/C1WS-10821
- Updated Deep Security Agent to increase the MQTT timeout from 30 minutes to 2 hours to help resolve connection issues on some systems. C1WS-11835

- Deep Security Agent was incorrectly generating system events showing that the Advanced Threat Search Engine (ATSE) component had been removed on some systems. SEG-147779/DS-75463
- Deep Security Agent upgrade sometimes failed because of a missing signature in the agent package. SF06045259/SEG-154576/DS-73668
- Application Control now checks web browser execution of .HTML, .HTM, and .JS files. DS-75102
- When a SOCKS proxy was used, Deep Security Agent failed to provide a Web Reputation Services rating for HTTP URLs. DS-73482/DS-73364
- Deep Security Agent security updates were failing due to a file handle issue that prevented files from being removed during an update. DS-75907
- Deep Security Agent Scanner (SAP) couldn't generate reports for files with one or more trailing dots . in their file name. SF06181341/SEG-166326/DS-76404

Known issues

- Deep Security Agent 20.0.0-6313 or later is currently unable to load the third-party libraries required to use Remote Shell, File Collection, or Network Isolation on the Windows 2008 platform. If you need these three features on a Windows 2008 system, refrain from upgrading your agent. DS-75176
- Updating Deep Security Agent causes Deep Security Manager to show an unknown error event (ID: 740) on some systems. A future Deep Security Manager release will address this issue. For more details, see [Unrecognized Agent\Appliance Error Event in Deep Security Manager \(Event ID 1010 - 1013\)](#). DS-76813

Deep Security Agent - 20.0.0-6313 (20 LTS Update 2023-01-31)

Release date: January 31, 2023

Build number: 20.0.0-6313

New features

Windows 10 22H2 support: Deep Security Agent 20.0.0-6313 or later with Deep Security Manager 20.0.716 or later now supports Windows 10 22H2.

Enhancements

- Deep Security no longer supports certificates signed with the SHA-1 algorithm. The agent now requires SSL certificates issued using SHA-256 to communicate with the Deep Security Manager. C1WS-5676

Warning: To prevent communication errors between the Deep Security Agent and Deep Security Manager, follow the instructions to [Upgrade the Deep Security cryptographic algorithm](#).

If you updated to Deep Security Agent 20.0.0-6313 or later before upgrading the cryptographic algorithms, follow the steps in [Deep Security Agent \(DSA\) offline when OpenSSL 3 rejects certificate with SHA-1 algorithm](#).

- With Anti-Malware and Behavior Monitoring enabled, Deep Security Agent now monitors for suspicious behavior to improve protection against MITRE attack scenarios. This functionality requires Deep Security Manager 20.0.711+. DS-73644
- Updated Deep Security Agent to support the "Trend Micro Toolbar for Enterprise" Chrome browser extension, improving HTTPS protection for Web Reputation Service. DS-74870

Resolved issues

- When Application Control was enabled, Deep Security Agent's status sometimes became stuck at "Application Control Ruleset Update In Progress". DS-74627
- An issue with the TLS protocol record layer in Deep Security Agent caused some systems to crash. SF06297487/SEG-162236/DSSEG-7774
- Deep Security Agent sometimes caused file handle leaks when communicating with Deep Security Manager or agent command-line tools. DS-75111
- For component updates, Deep Security Agent would attempt with and without use of a proxy and generate an event for each attempt. To make event reporting more straightforward, this behavior has been changed so that after a successful update the agent only shows the final successful event. SF06207160/SEG-160085/DSSEG-7765

- With Web Reputation Enabled, some characters entered in console commands were not being parsed properly. For example, an underscore (`_`) entered in a command was replaced with a dash (`-`), and an uppercase Z was replaced with a lowercase z. DS-74335

Deep Security Agent - 20.0.0-5995 (20 LTS Update 2022-11-28)

Release date: November 28, 2022

Build number: 20.0.0-5995

New features

Windows 11 22H2 support: Deep Security Agent 20.0.0-5995 or later with Deep Security Manager 20.0.711 or later now supports Windows 11 22H2.

Enhancements

- Updated Deep Security Agent to support the "Trend Micro Toolbar for Enterprise," a Chrome browser extension that extends HTTPS protection for Web Reputation Service. This is only supported for Trend Micro Cloud One - Workload Security customers at this time. DS-74568
- Updated the Web Reputation Service to support multi-thread processing on the web browser extension, improving the query rate. DS-74098
- Updated Deep Security Agent to include the details of command line Behavior Monitoring violations in the console under **Events and Reports > Events > Anti-Malware Events**. DS-72866

Resolved issues

- A file handle leak in the Deep Security notifier (`notifier.exe`) caused high system memory usage. DS-74325
- In Workload Security, enabling OS proxy (by setting **Allow agents to apply OS proxy or direct connect when the configured proxy is inaccessible** to Yes from **Administration > System Settings > Proxies**) would cause Deep Security Agent to crash if the proxy data the agent needed was missing on the operating system side. SEG-158968/DS-75034

- With Activity Monitoring enabled, high message volume sometimes made the internal MQTT channel inaccessible. This caused Deep Security Agent errors (MQTT offline, hub is busy, cannot connect to dsa-connect) as well as Trend Micro Vision One connectivity loss and the inability to send telemetry. SEG-160263/SEG-161138/SEG-160116/SEG-159318/DS-74638
- While running Application Control in maintenance mode, executable files that should have been accessible were sometimes blocked due to a sharing violation. SF04922652/SEG-131710/DS-74592
- Application Control was unable to block scripts executed using GitBash shell (sh.exe). DS-73827
- With Activity Monitoring enabled, Deep Security Agent caused file handle leaks on some systems. DS-74301
- Deep Security Agent caused an outdated "Early Launch Anti-Malware Pattern" component to appear on the Security Updates page, causing the Security Update Status to be "Out-of-Date". This pattern was unused, which is why it always appeared as an outdated component. SEG-158345/DSSEG-7745
- Deep Security Agent sometimes allowed a higher access level than the one set by a user's group. For example, the "Users" group was able to modify files even if it had read-only access. SEG-157530/DSSEG-7737
- With Anti-Malware enabled, a Deep Security Agent driver caused some systems running Windows Server 2008 to crash. SF05926337/SEG-157388/DSSEG-7739

Deep Security Agent - 20.0.0-5810 (20 LTS Update 2022-10-27)

Release date: October 27, 2022

Build number: 20.0.0-5810

New features

Installed software reporting: Deep Security Agent now reports installed software with additional details from the Microsoft Windows Installer. This is currently only available to Trend Micro Cloud One Workload Security customers.

Enhancements

- Updated Deep Security Agent to include additional metadata, such as `UserAgent` and `Referrer`, for Web Reputation Services. DS-72196
- Updated Deep Security Agent to include the Integrity Monitoring database in the agent diagnostic package. DS-73293
- Updated Deep Security Agent to support NULL cipher when inspecting TLS traffic with Intrusion Prevention. DS-71085

Resolved issues

- With Anti-Malware Behavior Monitoring enabled, uninstalling or upgrading from Deep Security Agent 20.0.0-5761 caused some systems to crash. For more details see [BSOD Encountered During Uninstall of Deep Security Agent 20.0.0-5761](#). DS-74322
 - With Activity Monitoring enabled, Deep Security Agent caused file handle leaks on some systems. DS-74301
 - With Activity Monitoring enabled, Deep Security Agent encountered a resource leak that caused system crashes, high memory usage affecting other applications, and agent connectivity issues leading to large numbers of reconnect attempts. SEG-154142/SEG-155126/SEG-156653/SEG-157277/SEG-156052/SEG-157254/SEG-156483
 - With Log Inspection enabled, Deep Security Agent sometimes generated "Abnormal Restart Detected" events. SF05951130/SEG-151372/DS-73737
 - If the Deep Security Agent service stopped while running Application Control in Maintenance Mode, executable files created after the service stopped were not being auto-approved as intended. SF05961688/SEG-152045/DS-73570
 - Software, if renamed or copied while Application Control had Maintenance Mode enabled, would remain authorized in the software inventory under its original filename or location. DS-74015
 - Virtual Machines using vMotion sometimes deactivated unexpectedly and displayed an "Offline (Activation required)" status. SEG-153050/DS-73807
 - The TLS inspection support package failed to download on Deep Security Agents using Edge Relay. DS-73789
-

- While an Application Control inventory build is in progress, the agent would sometimes appear offline. DS-72189

Known issues

- After upgrading the Deep Security Agent 20.0.0-5761 to 20.0.0-5810 on Windows, a reboot is required to solve an issue that causes computers to crash. For details including steps to work around the issue, see https://success.trendmicro.com/dcx/s/solution/000291718?language=en_US. DS-74383

Deep Security Agent - 20.0.0-5512 (20 LTS Update 2022-09-22)

Release date: September 22, 2022

Build number: 20.0.0-5512

Enhancements

- Deep Security Agent now supports the automatic update of Advanced TLS Traffic Inspection as operating system libraries change (**Computer** or **Policy** > **Settings** > **TLS Inspection Package Update**). This requires Deep Security Manager 20.0.677 or later. DS-72828

Resolved issues

- Integrity Monitoring events (**Events and Reports** > **Integrity Monitoring**) were created with N/A displayed in the KEY and TYPE columns. SF05533287/SEG-139293/DS-71899
 - Updating Deep Security Agent and removing the expired TLS session key caused some systems to crash. SF06007238/SEG-153175/DS-73404
 - With Anti-Malware enabled, some computers froze in a "Security Update In Progress" state. SF05106626/SEG-129777/DSSEG-7500
 - With Deep Security Agent self-protection enabled, enabling or disabling Advanced TLS inspection service caused "Event ID 7006" in the Windows Service Control Manager. DS-73305
 - Deep Security Agent reported host metadata in an unexpected format. DS-73411
-

Security updates

Security updates are included in this release. For more information about how Trend Micro protects against vulnerabilities, visit [Vulnerability Response](#). Note that in line with responsible disclosure practices, CVE details will only be made available for select security updates once patches have been made available for all impacted releases. VRTS-8100/VRTS-8101/DS-73087/DS-72528

Highest CVSS score: 7.0

Highest severity: High

Known issues

- With Activity Monitoring enabled, Deep Security Agent encountered a resource leak that caused system crashes, high memory usage affecting other applications, and agent connectivity issues leading to large numbers of reconnect attempts. SEG-154142/SEG-155126/SEG-156653/SEG-157277/SEG-156052/SEG-157254/SEG-156483

Deep Security Agent - 20.0.0-5394 (20 LTS Update 2022-08-29)

Release date: August 29, 2022

Build number: 20.0.0-5394

Enhancements

- Application Control now detects software changes for executables with non executable extensions. DS-70805
- Added SYSTEM user network drives and mount points for Windows to the information collected when generating a diagnostics package. DS-71816
- Updated Deep Security Agent to add support for inspecting packets using dynamic ports in a TLS connection. DS-71078
- Updated Deep Security Agent so Application Control automatically authorizes test PowerShell scripts created by AppLocker. DS-71762
- Behavior Monitoring exclusions now support wildcard characters. DS-71976

- Updated Deep Security Agent to add more metrics for Advanced TLS Inspection. DS-72833

Resolved issues

- When TLS inspection was done on a UDP connection with dynamic ports, the operating system would sometimes crash. SEG-151169/DS-73043
- Log Inspection Engine would go offline when using '\$' character in match or regex fields together with variables. SEG-146965/SEG-146966/DS-72325
- When assigning a policy with real-time Anti-Malware turned off to a new guest VM, it would sometimes turn off real-time Anti-Malware for all other guest VMs registered to the same Deep Security Virtual Appliance. SEG-146057/DS-72856
- When Behavior Monitoring is enabled, Deep Security Agent would sometimes prevent Docker on Windows from starting. SF05709278/SEG-146323/DSSEG-7660
- Application Control would still block access to network files while in maintenance mode. SF04922652/SEG-131710/DS-72037
- When Application Control is enabled, Adobe plugins were generating unexpected security events. SF05823607/SEG-148570/DS-72679
- Deep Security Agent would sometimes retrieve incorrect PID information on Windows for connection metrics and log events. DS-72526
- Deep Security Agent would return "revision mismatch (-10039)" errors when loading certain configuration files during an agent update. DS-72499
- Deep Security Agent would report detected software changes before Application Control inventory scan was completed. DS-72071
- When Anti-Malware accessed files on a Cluster Shared Volume, the Hyper-V host would crash. SF05713918/SF05850687/SEG-146660/SEG-148664/DSSEG-7664

Known issues

- When executing multiple custom script tasks, new tasks are currently overwritten by previous unfinished tasks. You can execute custom script tasks one by one to bypass this issue. Note that this issue will be fixed in a future release. DS-72699
- Deep Security Agent 20.0.0-5137 or later is unable to load the third-party libraries needed for Activity Monitoring on Windows 2008 platform. If you need Activity

Monitoring for a Windows 2008 system, refrain from upgrading your agent. Note that this issue will be fixed in a future release. DS-72573

Deep Security Agent - 20.0.0-5137 (20 LTS Update 2022-07-26)

Release date: July 26, 2022

Build number: 20.0.0-5137

New features

Advanced TLS Traffic Inspection: Deep Security Agent 20.0.0-5137 or later adds Advanced TLS Traffic Inspection support to platforms that run system updates or package updates. Note that this feature is currently only supported for Trend Micro - Cloud One Workload Security. Support for Deep Security Manager (On-Premise) will be added later.

Enhancements

- Deep Security Agent 20.0.5137 or later for Windows uses an additional certificate: "Microsoft Identity Verification Root Certificate Authority 2020". For details see the following article: https://success.trendmicro.com/dcx/s/solution/1104241-Updating-the-VeriSign-DigiCert-USERTrust-RSA-certificate-on-Deep-Security-and-Cloud-One-Workload-Security?language=en_US. DS-72711
- Deep Security Agent Scanner (SAP) now generates infection reports with additional details. DS-71660
- Updated Deep Security Agent to improve the "zero-config" SSL process for outbound connections. DS-70715
- Updated Deep Security Agent to improve Trust Entities functionality. Trust rule wildcard support now includes globstar `**` which matches many sub directories. Single star `*` now only matches within your current directory. Existing rules that used a single star `*` to match many folders no longer work and need to be changed to use a globstar `**`. DS-71817

Resolved issues

- With Anti-Malware enabled, Deep Security Agent had a driver conflict causing some third-party applications to freeze. SF05570686/SEG-140749/DSSEG-7650

- Deep Security Agent's Scanner (SAP) library install sometimes failed because required certificates on hosts were outdated. DS-71917
- Deep Security Agent SAP scanner could not detect the MIME (.TTF) files. DS-55897
- Intrusion Prevention rules with certain setting combinations failed to compile. DS-71889

Security updates

Security updates are included in this release. For more information about how Trend Micro protects against vulnerabilities, visit [Vulnerability Response](#). Note that in line with responsible disclosure practices, CVE details will only be made available for select security updates once patches have been made available for all impacted releases. VRTS-7102/VRTS-7070/VRTS-7041/VRTS-7039/DSSEG-7636

Highest CVSS score: 4.4

Highest severity: Medium

Known issues

- When executing multiple custom script tasks, new tasks are currently overwritten by previous unfinished tasks. You can execute custom script tasks one by one to bypass this issue. Note that this issue will be fixed in a future release. DS-72699
- Deep Security Agent 20.0.0-5137 is unable to load the third-party libraries needed for Activity Monitoring on Windows 2008. If you need Activity Monitoring for a Windows 2008 system, refrain from upgrading to Deep Security Agent 20.0.0-5137. Note that this issue will be fixed in a future release. DS-72573

Deep Security Agent - 20.0.0-4959 (20 LTS Update 2022-07-04)

Release date: July 4, 2022

Build number: 20.0.0-4959

Resolved issues

- Deep Security Agent caused increased CPU usage for systems running the WMI provider service (WmiPrvSE.exe). 05528968/SEG-142736/DS-71626
- Deep Security Agent Scanner (SAP) reports displayed .SAR files in the wrong order. DS-71651
- Deep Security Agent had a conflict preventing TMUMH drivers from loading (on Windows 11 and Windows 2022), and in some cases causing a system crash (affecting all Windows platforms). SEG-143164/DSSEG-7596
- Using the command line (`dsa_control -b`), Deep Security Relay failed to extract the bundle file required to update in a closed network environment. SF05715642/SEG-144571/DSSEG-7600
- With Log Inspection enabled, updates to Deep Security Agent 20.0.0-4726 encountered "Get Events Failed" and "Command Not Found" alerts. SF05738607/SEG-145679/DS-72117
- When Anti-Malware is enabled alongside either Integrity Monitoring or Activity Monitoring, Deep Security Agent caused high CPU usage. SF05169148/SEG-129522/DS-69594
- With Anti-Malware enabled, Deep Security Agent generated "Anti-Malware Engine Offline" errors caused by service restarts following a software upgrade. SF05521775/SEG-144639/DSSEG-7615
- With Anti-Malware enabled, Deep Security Agent sometimes caused a system crash or high system memory usage, or failed to deliver event reports. SF05475742/SEG-142632/DSSEG-7626
- Updated Deep Security Agent to immediately report its status to Deep Security Manager when Application Control's maintenance mode is enabled on the agent. DS-71617
- Deep Security Agent sometimes created unclear error log entries referencing "invalid" or "badly-formed" proxy URLs. SEG-144613/DS-71866

Security updates

Security updates are included in this release. For more information about how Trend Micro protects against vulnerabilities, visit [Vulnerability Response](#). Note that in line with responsible disclosure practices, CVE details will only be made available for select

security updates once patches have been made available for all impacted releases.
VRTS-7633/DS-71687

Highest CVSS score: 6.2

Highest severity: Medium

Deep Security Agent - 20.0.0-4726 (20 LTS Update 2022-05-31)

Release date: May 31, 2022

Build number: 20.0.0-4726

Enhancements

- Updated Deep Security Relay to record its status and other metrics for potential troubleshooting. DS-65763

Resolved issues

- Trust Entities "Allow by target" rules sometimes blocked processes they weren't intended to block. SF04922652/SEG-131710/DS-71060
- Deep Security Agent reported false positive "Created/Deleted" Integrity Monitoring events under some configurations. SF05434164/SEG-136425/DS-70656
- Updated Deep Security Relay to prevent Deep Security Agent from retrieving incomplete signature files for packages. SF05332854/SEG-134394/DS-71228
- Deep Security Agent had connectivity issues caused when a Server Name Indicator (SNI) used an invalid format. SEG-127761/DS-70806
- An abnormal restart of Deep Security Agent sometimes lead to "Anti-Malware Engine Offline" errors. SEG-140234/DS-71333
- With Intrusion Prevention enabled, a packet transmission error caused some systems to crash. SEG-136843/DSSEG-7524

Security updates

Security updates are included in this release. For more information about how Trend Micro protects against vulnerabilities, visit [Vulnerability Response](#). Note that in line with responsible disclosure practices, CVE details will only be made available for select

security updates once patches have been made available for all impacted releases.
VRTS-7090/DSSEG-7541/DS-52329

Highest CVSS score: 7.5

Highest severity: High

Deep Security Agent - 20.0.0-4416 (20 LTS Update 2022-04-28)

Release date: April 28, 2022

Build number: 20.0.0-4416

Enhancements

- Updated Deep Security Agent to improve Intrusion Prevention performance when the "Bypass Network Scanner" rule was applied. DS-69515
- Updated Deep Security Agent to support enabling the Anti-Malware module while Windows Defender is running in passive mode under some system configurations DS-69161. Currently this is only supported on systems running the following versions:
 - Defender (AM) product / engine versions:
 - AMProductVersion: 4.18.2202.4
 - AMEngineVersion: 1.1.18900.3
 - Windows server and desktop versions:
 - Windows Server 2016 and newer
 - Windows 10 x64 RS5 and newer
 - Deep Security Agent 20.0.0-4416+

Resolved issues

- Deep Security Agent generated multiple "Anti-malware Engine Offline" events during agent upgrades under some system configurations. SF04500910/SEG-129316/DSSEG-7458

Security updates

Security updates are included in this release. For more information about how Trend Micro protects against vulnerabilities, visit [Vulnerability Response](#). Note that in line with responsible disclosure practices, CVE details will only be made available for select security updates once patches have been made available for all impacted releases.

VRTS-7132/DS-70518

Highest CVSS score: 7.5

Highest severity: High

Deep Security Agent - 20.0.0-4185 (20 LTS Update 2022-04-06)

Release date: April 6, 2022

Build number: 20.0.0-4185

New features

Advanced TLS traffic inspection: Advanced TLS traffic inspection adds the capability for inspecting TLS traffic encrypted with modern ciphers, including Perfect Forward Secrecy (PFS). It also enhances virtual patching for HTTPS servers to help protect against vulnerabilities such as Log4j.

Enhancements

- Updated Deep Security Agent to properly execute Application Control settings for software changes made during a Windows upgrade. Previously, trust rules auto-authorizing software changes associated with a Windows upgrade would fail if Application Control was in lock down mode. DS-69579
- When certificates are missing for an Anti-Malware installation, Deep Security Agent now forwards the certificate details to Deep Security Manager. The specific certificates missing will appear in the manager under **Events and Reports > System Events**. DS-69074

Resolved issues

- Running an Anti-Malware manual scan using the command line sometimes made Deep Security Agent unable to receive incoming connections. SF05385865/SEG-135256/DS-70364
- Deep Security Agent created an "Application Control Engine Offline" error during agent upgrade, and an "Application Control Engine Online Again" message after upgrade completion. Note that an upgrade should not have triggered these events. DS-69888
- Application Control sometimes blocked unrecognized software even when running in maintenance mode. SF05234969/SEG-133594/DS-69752
- Deep Security Agent sometimes consumed a high amount of system resources during policy updates. SEG-134417/DS-69810

Deep Security Agent - 20.0.0-3964 (20 LTS Update 2022-03-01)

Release date: March 1, 2022

Build number: 20.0.0-3964

New features

Threat Intelligence: Threat Intelligence (formerly known as Connected Threat Defense) provides enhanced malware protection for new and emerging threats. For more information, visit [Detect emerging threats using Threat Intelligence](#).

Enhancements

- Updated Deep Security Agent to exclude suspicious characters, such as \$, found in strings from the "Original IP (XFF)" field for Intrusion Prevention events. SEG-129905/DS-68989

Resolved issues

- Deep Security Agent accepted policy change parameters even if the self-protection password verification did not pass. SF05177188/SEG-129643/DS-69293

- Deep Security Agent sometimes went offline unexpectedly after activation. SEG-130280
- With Intrusion Prevention enabled, issues establishing an SSL connection caused "Unsupported SSL Version" events. SF04955719/SEG-127437/DS-68689
- Deep Security Agent was generating unexpected "Log File Delete Error" system events. DS-69641
- Deep Security Agent sometimes created unnecessary User (Created/Deleted) or Group (Added/Removed/Updated) events. DS-62413

Deep Security Agent - 20.0.0-3771 (20 LTS Update 2022-01-24)

Release date: January 26, 2022

Build number: 20.0.0-3771

New features

Zero config IPS inspection: Deep Security Agent adds the capability for Intrusion Prevention to inspect TLS encrypted traffic without manually importing certificates. This adds support for more cipher suites as well. This feature is being rolled out gradually for Windows platforms, beginning with Trend Micro Cloud One - Workload Security customers.

Windows 21H2 support: Deep Security Agent 20.0.0-3771 or later now supports Windows 21H2.

Enhancements

- Updated Deep Security Agent to allow Intrusion Prevention to connect to Deep Security Manager if the manager is using TLS 1.2 strong ciphers. DS-69042

Resolved issues

- Pairing Deep Security Agent with a proxy failed on Windows 11 when the "http://" prefix was unexpectedly added to the proxy address. The prefix was added if the address was accessed from the LAN settings window (**Control Panel > Network and Internet > Internet Options > Connections > LAN settings**), and then the window was closed by selecting OK. DS-68568

- Deep Security Agent security update would fail and generate "AMSP" events if Anti-Malware was offline during the update. SF04696674/SEG-120215/DSSEG-7287
- Application Control, Anti-Malware, and Real-time Integrity Monitoring failed to function properly for Deep Security Agents with certain combinations of Integrity Monitoring rules configured. DS-68494
- Updated Deep Security Agent to enable "Write Defer Scan" by default for real-time Anti-Malware scanning, resulting in increased response time, faster processing, and reduced CPU usage. Previously, all files were scanned during read/write by default. Now, Anti-Malware file scanning during write is deferred (the file is added to a queue and scanned in the background). DS-66344
- With Smart Scan enabled, Deep Security Agent was downloading the full size pattern update file, instead of the incremental one it was expected to, during security updates SEG-124937/DSSEG-7317

Security updates

Security updates are included in this release. For more information about how Trend Micro protects against vulnerabilities, visit [Vulnerability Response](#). Note that in line with responsible disclosure practices, CVE details will only be made available for select security updates once patches have been made available for all impacted releases. VRTS-6187/DS-65070/DS-68180

Highest CVSS score: 9.1

Highest severity: High

Deep Security Agent - 20.0.0-3530 (20 LTS Update 2021-12-15)

Release date: December 15, 2021

Build number: 20.0.0-3530

New features

- **OS proxy support:** Deep Security Agent 20.0.0-3530 or later for Windows can now apply proxy settings from the computer's OS to automatically connect to Trend Micro Cloud One - Workload Security, Deep Security Relay, and other Trend

Micro backend services if the default agent-configured proxy loses its connection. **This feature is only available to certain Workload Security customers at this time.**

Important Notes

- Pairing Deep Security Agent with a proxy currently fails on Windows 11 when the "http://" prefix is unexpectedly added to the proxy address after accessing it (under **Control Panel > Network and Internet > Internet Options > Connections > LAN settings**) and then selecting **OK** to close the window. This issue will be fixed in a future release. DS-68568

Resolved issues

- With Smart Scan enabled, Deep Security Agent downloaded the full size pattern update file instead of the incremental one it was expected to during security updates. DSSEG-7317

Deep Security Agent - 20.0.0-3445 (20 LTS Update 2021-11-24)

Release date: November 24, 2021

Build number: 20.0.0-3445

New features

- **Anti-Malware offline scheduled scan:** Deep Security Agent 20.0.0-3445 or later adds the offline scheduled scan feature, enabling Anti-Malware scheduled scans to run while an agent is not connected to Cloud One Workload Security. **This feature is only available to certain Cloud One Workload Security customers at this time.**
- **Windows 11 support:** Deep Security Agent 20.0.0-3445 or later now supports Windows 11.
- **Windows Server 2022 support:** Deep Security Agent 20.0.0-3445 or later now supports Windows Server 2022.

Enhancements

- Updated Deep Security Agent allow the Deep Security Notifier to be locked on (when installed through the command prompt using `msiexec /I "Notifier's installer name" LockAppSettingsDefault=1`), preventing users from hiding notifications. DS-64527
- Deep Security Agent sometimes crashed when it could not connect to Deep Security Manager. DS-67654
- Deep Security Agent no longer uses CBC cipher suites by default in order to improve security. DS-67204
- Updated Deep Security Agent to support using the "process name" property in "Ignore from source" rules for [Application Control Trust Entities](#) on Cloud One Workload Security. DS-67322
- Updated Deep Security Agent's database size management to optimize disk space usage. DS-67347

Resolved issues

- With Anti-Malware enabled, Deep Security Agent caused connectivity issues for third-party software on some systems. SF04087024/SEG-125579/DSSEG-7321
- Deep Security Agent sometimes showed plugin installation failures during an upgrade even when the upgrade was successful. DS-67336
- When an expired certificate was removed from the host, the Anti-Malware plug-in update would fail, creating "Anti-Malware Component Update" events. SEG-117871/DS-66139
- If an Anti-Malware scan began before the module had completed its installation on Deep Security Agent, it could cause a system crash and "Anti-Malware Engine Offline" errors after a reboot. SEG-108355/DS-63721
- With Activity Monitoring enabled, Deep Security Agent sometimes crashed due to an issue with SQLite. 04958386/SEG-123752/DSSEG-7300
- Deep Security Agent couldn't properly handle SAP NetWeaver MIME type scan requests containing leading and trailing spaces. DS-67448
- When Integrity Monitoring rules using "UserSet" or "GroupSet" were enabled for a Deep Security Agent on Windows Active Directory Domain Controllers, excessive CPU and memory consumption would sometimes occur. Deep Security Agent

20.0.0-3445 blocks these types of Integrity Monitoring rules on Windows Active Directory domain controllers and generates an "Inapplicable Integrity Monitoring Rule" event. DS-65965

Security updates

Security updates are included in this release. For more information about how Trend Micro protects against vulnerabilities, visit [Vulnerability Response](#). Note that in line with responsible disclosure practices, CVE details will only be made available for select security updates once patches have been made available for all impacted releases. VRTS-6489/DSSEG-7210/DS-65113/VRTS-6207/DSSEG-7026

Highest CVSS score: 7.8

Highest severity: High

Deep Security Agent - 20.0.0-3288 (20 LTS Update 2021-10-28)

Release date: October 28, 2021

Build number: 20.0.0-3288

New features

- **Evolution of the agent installer:** The Deep Security Agent installer now installs most agent content. This results in the following changes:
 - Agent size requirements have increased, including a slightly larger installer package on most platforms.
 - All agent content is now installed on the computer being protected. Content remains unloaded on a computer until a plug-in is activated by a policy or by the manager console.
 - The agent is now much less dependent on relays because all plug-in installations use the content already installed with the agent. This mitigates plug-in install issues due to relay communications because plug-ins can be installed without a connection to a relay.

Resolved issues

- On Deep Security Agent 20.0.0-3165, "Anti-Malware Component Update Failed" events were sometimes generated when computers performed security updates. This defect is now fixed in Deep Security Agent 20.0.0-3288. SF04937346/SEG-122765/DSSEG-7268
- With Intrusion Protection enabled, Deep Security Agent sometimes caused high CPU usage and sometimes caused the system to crash. DS-65902
- With Intrusion Protection enabled, Deep Security Agent caused the system to crash under some configurations. SF04931669/SEG-123338/DS-67441
- With SAP integrated and running, Deep Security Agent would block MP4 files. 04660120/SEG-117094/DSSEG-7254
- Deep Security Agent sometimes was unable to connect to the manager via proxies. DS-65929
- CPU usage would spike when Deep Security Agent queried the runtime status of the Anti-Malware component. DSSEG-7222
- Deep Security Agent did not always check that metadata was ready before initializing connection with the manager. DS-51103
- Deep Security Agent sometimes showed package signature errors during an upgrade because of a mismatched Certification Revocation List (CRL). DS-65056

Security updates

Security updates are included in this release. For more information about how Trend Micro protects against vulnerabilities, visit [Vulnerability Response](#). Note that in line with responsible disclosure practices, CVE details will only be made available for select security updates once patches have been made available for all impacted releases. DS-46018/DSSEG-7210/DSSEG-7217

Highest CVSS score: 7.8

Highest severity: High

Deep Security Agent - 20.0.0-3165 (20 LTS Update 2021-10-08)

Release date: October 08, 2021

Build number: 20.0.0-3165

Note: Deep Security Agent 20.0.0.3165 has been released to Trend Micro Cloud One - Workload Security customers. However, it is not available on the Deep Security Agent software download page or released to customers using Deep Security Manager.

New features

- **Evolution of the agent installer:** The Deep Security Agent installer now installs most agent content. This results in the following changes:
 - Agent size requirements have increased, including a slightly larger installer package on most platforms.
 - All agent content is now installed on the computer being protected. Content remains unloaded on a computer until a plug-in is activated by a policy or by the manager console.
 - The agent is now much less dependent on relays because all plug-in installations use the content already installed with the agent. This mitigates plug-in install issues due to relay communications because plug-ins can be installed without a connection to a relay.

Resolved issues

- Deep Security Agent sometimes was unable to connect to Manager via proxies. DS-65929
- CPU usage would spike when Deep Security Agent queried the runtime status of the Anti-Malware component DSSEG-7222
- Deep Security Agent did always check that metadata was ready before initializing connection with the manager. DS-51103

Security updates

Security updates are included in this release. For more information about how Trend Micro protects against vulnerabilities, visit [Vulnerability Response](#). Note that in line with responsible disclosure practices, CVE details will only be made available for select security updates once patches have been made available for all impacted releases. DSSEG-7210/DSSEG-7217

Highest CVSS score: 7.8

Highest severity: High

Deep Security Agent - 20.0.0-2921 (20 LTS Update 2021-08-30)

Release date: August 30, 2021

Build number: 20.0.0-2921

New features

Census feedback: Deep Security Agent 20.0.0-2921 or later can now send census file feedback to the Smart Protection Network (SPN) if Trend Micro Smart Feedback is enabled (**System Settings > Smart Feedback**).

Enhancements

- Updated Deep Security Agent to detect the "HiveNightmare" exploit. DS-65217

Resolved issues

- With Application Control enabled, Deep Security Agent sometimes crashed when a .MSI file was launched. SF04647983/SEG-114894/DSSEG-7032
- Deep Security Agent console commands sometimes failed to return proxy information for Deep Security Relay or Deep Security Manager. DS-65419
- Deep Security Agent sometimes failed to properly display items under **Events and Reports**. DSSEG-7057

Security updates

Security updates are included in this release. For more information about how Trend Micro protects against vulnerabilities, visit [Vulnerability Response](#). Note that in line with responsible disclosure practices, CVE details will only be made available for select security updates once patches have been made available for all impacted releases. DSSEG-7046/DS-65668

Highest CVSS score: 7.8

Highest severity: High

Deep Security Agent - 20.0.0-2740 (20 LTS Update 2021-07-29)

Release date: July 29, 2021

Build number: 20.0.0-2740

Enhancements

- Updated Deep Security Agent to improve TLS traffic inspection. This feature is being rolled out gradually, beginning with Trend Micro Cloud One - Workload Security customers. DS-15576
- Updated Deep Security Agent to improve connectivity with Deep Security Manager during agent deployment and activation. DS-62547

Resolved issues

- With Application Control enabled, files with '.tmp' extensions were creating a large number of "Application Control Software Changes Detected" events in the Deep Security Manager console. 04671615/SEG-115017/DS-65043
- Deep Security Agent failed to execute some agent-initiated (dsa_control) console commands. 04564385/SEG-112050/DSSEG-6990
- Deep Security Agent sometimes crashed while trying to establish a connection with Deep Security Manager. 04634804/SEG-113539/DS-64862
- Deep Security Agent sometimes lost connectivity while trying to establish an SSL connection. SF04323898/SEG-107451/DS-64268
- Deep Security Agent was sometimes unable to connect to web applications on systems with older OS versions. SF04451029/SEG-109652/DS-64528
- With Web Reputation enabled, Deep Security Agent caused connectivity issues for some third-party software. SF04072723/SEG-97952/DSSEG-6963

Security updates

Security updates are included in this release. For more information about how Trend Micro protects against vulnerabilities, visit [Vulnerability Response](#). Note that in line with responsible disclosure practices, CVE details will only be made available for select security updates once patches have been made available for all impacted releases. SF04613197/SEG-113566/DS-64050

Highest CVSS score: 9.8

Highest severity: High

Deep Security Agent - 20.0.0-2593 (20 LTS Update 2021-07-01)

Release date: July 01, 2021

Build number: 20.0.0-2593

Resolved issues

- Deep Security Agent sometimes triggered multiple "Log Inspection Engine Initialized" alerts due to an agent-manager communication issue. SF03968169/SEG-95731/DS-60840
- The MQTT connection sometimes went offline when Deep Security Agent had Activity Monitoring enabled. SF04216172/SEG-101691/DS-63458
- Anti-Malware sometimes went offline after enabling Application Control on Deep Security Agent. SF04532752/SEG-110572/DS-63406
- Application Control was detecting multiple "Application Control Software Changes Detected" events due to ".tmp" files being generated by PowerShell. C1WS-1608
- Citrix Virtual App or Desktop users sometimes encountered a grey screen (with error code 1003/1005) when Anti-Malware was enabled for Deep Security Agent. DS-64318
- Anti-Malware sometimes caused high system CPU usage when the Windows WMI service accessed files repeatedly. SEG-109271/DSSEG-6983

Security updates

Security updates are included in this release. For more information about how Trend Micro protects against vulnerabilities, visit [Vulnerability Response](#). Note that in line with responsible disclosure practices, CVE details will only be made available for select security updates once patches have been made available for all impacted releases. VRTS-5850/DS-54705

Highest CVSS score: 4.4

Highest severity: Medium

Deep Security Agent - 20.0.0-2419 (20 LTS Update 2021-06-02)

Release date: June 02, 2021

Build number: 20.0.0-2419

Resolved issues

- Deep Security Agent 20.0.0-2395 for Windows always displayed an "Out-of-Date" Security Update Status. This agent was removed from the [Trend Micro Download Center](#). For more information see [Removal of Deep Security Agent 20.0.0-2395 for Windows](#). SF04537047/SEG-110737/DS-63424
- Integrity Monitoring alerts sometimes triggered but then did not appear in the **Events and Reports** tab. 04266346/SEG-103731/DS-62992
- Items queued for Anti-Malware scan sometimes caused higher than normal Deep Security Agent CPU usage. DS-63106
- Deep Security Agent sometimes showed package signature errors during an upgrade because of a mismatched Certification Revocation List (CRL). DS-62154
- Insufficient host information caused by connectivity issues sometimes resulted in offline or duplicate listings in the **Computers** tab for Deep Security Agents on AWS workspaces. SF04198134/SEG-102818/DS-61666
- Deep Security Agent sometimes couldn't successfully perform an upgrade because of a missing package. SF04302125/SEG-104084/DS-62692

Deep Security Agent - 20.0.0-2204 (20 LTS Update 2021-04-12)

Release date: April 12, 2021

Build number: 20.0.0-2204

Resolved issues

- When Application Control was in block mode, it was unable to build a proper software inventory in some cases. DS-58813
 - When Web Reputation was enabled, the system sometimes crashed. SF04258834/SEG-102756/DS-61067
-

- When Anti-Malware self-protection was enabled, sometimes third-party software could not be installed. SEG-101840/DSSEG-6694
- Behavior Monitoring exceptions sometimes did not work properly. SF03775351/SEG-89899/DSSEG-6718
- With Anti-Malware enabled, network transfer speeds slowed down significantly on some systems. SF04299217/SEG-103986/DSSEG-6780
- Anti-Malware Behavior Monitoring exceptions sometimes did not work properly. SF04259521/SEG-102792/DSSEG-6714

Deep Security Agent - 20.0.0-2009 (20 LTS Update 2021-03-08)

Release date: March 08, 2021

Build number: 20.0.0-2009

Enhancements

- Updated Deep Security Agent to include CPU information (number of logical cores) to improve diagnostics and performance tracking. DS-60011

Resolved issues

- The MQTT connection went offline because an old MQTT connection was not properly cleaned. SF04236908/SEG-102056/DS-60893
- Behavior Monitoring sometimes blocked a program without generating an event. SF03604820/SEG-86752/DS-60526
- When Anti-Malware was enabled, a high amount of CPU was used. SF04106889/SEG-99034/DS-60526
- Deep Security Agent sometimes crashed during an Anti-Malware manual scan. SEG-100231/DSSEG-6664

Deep Security Agent - 20.0.0-1876 (20 LTS Update 2021-02-08)

Release date: February 08, 2021

Build number: 20.0.0-1876

Resolved issues

- The Deep Security Agent sometimes crashed when running Intrusion Prevention in passive mode. DS-57497
- Activity Monitoring data could not be transferred to XDR because a proxy connection was established without a relevant port. SEG-97519

Deep Security Agent - 20.0.0-1822 (20 LTS Update 2021-01-18)

Release date: January 20, 2021

Build number: 20.0.0-1822

Resolved issues

- After a Windows update occurred, "Maintenance mode" for Application Control turned off automatically. SF03905860/SEG-93631/DS-58413

Deep Security Agent - 20.0.0-1681 (20 LTS Update 2021-01-04)

Release date: January 04, 2021

Build number: 20.0.0-1681

This release contains general improvements.

Deep Security Agent 20.0.0-1559 (20 LTS Update 2020-12-07)

Release date: December 07, 2020

Build number: 20.0.0-1559

New features

Enhanced platform support

- Windows 10 20H2

Improved security

TLS Directionality: The manager heartbeat port can now act as both a TLS client and TLS server. Future agents will connect as TLS clients, not TLS servers. This resolves issues with agent-initiated connections through a proxy or firewall that requires TLS sessions to be initiated in the same direction as the TCP layer of the connection.

Enhancements

- Improved Deep Security Relay's performance by only checking packages that have been modified. DS-55527
- Improved Deep Security Agent to better support Activity Monitoring on Trend Micro Cloud One - Workload Security. For more information, see [Enable Activity Monitoring](#). DS-55230
- Enhanced memory usage to improve performance. DS-53012
- Deep Security Agent now supports custom actions for Behavior Monitoring and Predictive Machine Learning. DS-48081

Resolved issues

- When Integrity Monitoring was enabled, a high amount of CPU was used. SEG-88619/03720485/DS-56613
- Application Control events occurred multiple times for the same incident. SEG-86213/SF03620055/DS-57298
- Security updates were not automatically performed on new machines. SEG-91484/SF03828068/DS-57688

Notice

In this agent update there is a change to how the validation of the TLS certificate used for agent-manager communication is implemented. If you see the following warning during agent activation:

```
[Warning/2] | SSLVerifyCallback() - verify error 20: unable to get local issuer certificate
```

The most likely root cause is that agent cannot validate the certificate being presented to it by the manager. Pinning a trusted certificate is optional, so you can ignore this error

if it doesn't apply to you. However, if you'd like to use a trusted certificate, follow the steps in ["Import a Deep Security Manager certificate chain issued by a public CA" on page 1569](#) before activating the Deep Security Agent.

Deep Security Agent 20.0.0-1337 (20 LTS Update 2020-10-28)

Release date: October 28, 2020

Build number: 20.0.0.1337

New features

Upgrade to supported paths: The Upgrade on activation feature only upgrades the agent on the computer from the last two major releases. If the agent does not meet the criteria, you must upgrade the agent manually to a release within the last two major releases. Then the Upgrade on activation feature detects the newer version and complete the upgrade to the designated release.

Enhancements

- Added various executable files as trusted installers so they are automatically recognized by Application Control. SF03568205/SEG-85141/DS-54884
- Extended the scope of the "If a computer with the same name already exists" setting on **Administration > System Settings > Agents** to apply to existing unactivated computers. Previously, it only applied to existing activated computers. DS-51800/DS-51879
- Real-time Integrity Monitoring explicitly matches the directory specified in the base directory. Previously, it matched all paths that started with the base directory. DS-52692
- Updated the Integrity Monitoring scan completion time in Deep Security Manager events to display in seconds with a thousands separator. DS-54680

Resolved issues

- In combined mode with agent-only and agent-preferred settings enabled, Deep Security Notifier sometimes turned the Antivirus status in the Windows action center on and off, which caused high CPU. DS-54799

- After upgrading the Deep Security Agent, the "Sending Application Control Ruleset Failed" error sometimes occurred. DS-49828
- The Behavior Monitoring feature of Anti-Malware sometimes raised false alarms. DS-44974
- When Integrity Monitoring was enabled, the owner of a file was incorrectly changed to a user that did not exist. DS-52058
- When "Serve Application Control rulesets from relays" was enabled, unnecessary relay error events occurred. DS-50905
- Deep Security Agent crashed unexpectedly because it was unable to detect the Docker engine version on Windows Servers. DS-29590
- Deep Security Manager reported a security update timeout because Deep Security Agent received exceptions at security updates. SEG-82072/DS-54720
- There were detection issues with real-time Anti-Malware scans. DS-50286
- Deep Security Manager sometimes showed the incorrect Log Inspection status. SEG-77081/DS-54719
- When a re-transmission packet with new packets was sent, it sometimes produced an "Unsupported SSL Version" Intrusion Prevention event. DS-53144

Security updates

Security updates are included in this release. For more information about how Trend Micro protects against vulnerabilities, visit [Vulnerability Response](#). Note that in line with responsible disclosure practices, CVE details will only be made available for select security updates once patches have been made available for all impacted releases. VRTS-3704/DS-41233

Highest CVSS score: 4.4

Highest severity: Medium

Action required: Customers participating in the Trend Micro XDR Activity Monitoring preview for Workload Security

This Deep Security Agent release includes required updates for the Trend Micro XDR Activity Monitoring preview. If you are currently participating in the preview, you must upgrade to Deep Security Agent 20.0.0-1337 or later by November 16, 2020. If you do

not upgrade to Deep Security Agent 20.0.0-1337 or later, Activity Monitoring data will stop being collected on November 16, 2020. For more information about XDR and Activity Monitoring, see [Integrate Workload Security with XDR](#).

Note: Deep Security Agent 20.0.0-1337 or later uses a new network connection to send Activity Monitoring data to Trend Micro. The connection details can be found in [Enable Activity Monitoring](#). Ensure that agent traffic to this destination is allowed so Activity Monitoring data can be sent to Trend Micro.

Known issues

While the Deep Security Relay is upgrading co-located or independent relays, the alerts "Anti-Malware protection is absent or out of date" and "Security Update: Security Update Check and Download Failed (Agent/Appliance error)" might occur for up to 20 minutes or longer before they're automatically resolved and the respective alerts cleared. For any subsequent Deep Security Agent upgrades to succeed, wait for the Deep Security Relay alerts to clear automatically. DS-54056

Deep Security Agent 20 (long-term support release)

Release date: July 30, 2020

Build number: 20.0.0.877

New features

Improved security

Agent integrity check: Deep Security verifies your signature on the Deep Security Agent to ensure that the software files have not changed since the time of signing.

Protect AWS accounts with incorrect credentials: In the past, if your credentials were entered incorrectly for AWS accounts in Deep Security, the agent failed to activate. This might have occurred because the credentials were entered incorrectly or because, over time, the credentials changed without a corresponding update on Deep Security. To help ensure protection remains in place in this situation, which in many cases is a simple configuration error, the computer is now created outside of the account and the agent is allowed to activate.

SSL improvements: Deep Security supports handshake `hello_request` (rfc5246) and Extension `encrypt_then_mac` (rfc7366) in SSL inspection.

Improved quality and management

Reboot requirement removed for agent upgrade: Previously, there were several situations where a Windows server would require a reboot for a new agent to complete the upgrade. The need to reboot when upgrading from Deep Security Agent 11.0, 12.0, or 20.0 on any Windows Operating System has been completely removed, enabling the application to not be impacted as result of upgrading Deep Security Agent.

Automate the upgrade of agents in your environment: Deep Security gives you the flexibility to decide if new agents, when activated, should be upgraded to a newer version if one is available. This can be particularly useful in cases where application teams are using older golden images containing a version of the agent that is out of date. Simply enable upgrade on activation, define the lineup of agents you want to use in your environment using Agent Version Control, and as older agents come online and activate they are automatically upgraded for you.

Instance Metadata Service Version 2 (IMDSv2) support: IMDSv2 is supported with Deep Security Manager FR 2020-04-30. For details, see ["How does Deep Security Agent use the Amazon Instance Metadata Service?" on page 1911](#)

Actionable recommendations for scan failures: The Deep Security Agent provides actionable information about why a scheduled malware scan has been canceled, and the recommended actions that should be taken to remedy the failure. For more information, see ["Anti-Malware scan failures and cancellations" on page 1133](#).

Anti-Malware real-time file scan report: Deep Security has the ability to determine the top 10 files that are scanned by Anti-Malware real-time scan. This provides a starting point for performance evaluating and tuning, as you can use this information to set file exclusions and avoid unnecessary scans. The 'AmTopNScan.txt' file with the collected data can be generated using the following methods:

- By the command `dsa_control --AmTopNScan`
- By the diagnostic service

Improved process exceptions: The process exception experience has been improved in the following ways:

- Information about why process exclusion items are not functioning correctly is now provided, so you can troubleshoot the issue and know which actions to take to resolve it.
- The process exception configuration workflow has been improved to make it more robust.

Windows Event Channel for Log Inspection: Windows Event Channel logging provides a new option for tracking OS and Application logging for Windows platforms newer than Windows Vista. Event channels can be used to collect Log Inspection events which you can view later.

Enhancements

- Improved the heartbeat handling for Amazon WorkSpaces deployments when the workspace sync feature is not turned on for the matching AWS connector.
- Removed Integrity Monitoring and Application Control's dependency on Anti-Malware, so they no longer require Anti-Malware to be installed to function.
- Added the ability for Deep Security Agent Anti-Malware to scan compressed files no matter their data types when IntelliScan is disabled.
- Added support for agentless mode on vCloud connector for version 9.5 or later.
- Enhanced the agent-initiated activation experience by displaying the activation status (for example, a success message or a message that explains a newer Deep Security Manager version is required) on Deep Security Manager.
- Enhanced the Malware Scan Failure event description to indicate the possible reason.
- Streamlined event management for improved agent performance.
- Added the ability to enable or disable Common Scan Cache for each agent through a CLI command.
- Added support for Deep Security Agent delayed upgrade to reduce the Anti-Malware offline issue after triggering an upgrade.

Resolved issues

- After upgrading the Deep Security Agent, the "Sending Application Control Ruleset Failed" error sometimes occurred. DS-49828

- Application Control occasionally appeared offline when Application Control and Anti-Malware were enabled at the same time.
 - Deep Security Agent restarted unexpectedly because of the way Log Inspection was accessing the SQLite database. DS-48395
 - The interface isolation feature stayed active when Firewall was turned off. SEG-32926/DS-27099
 - Web Reputation, Firewall, Intrusion Prevention, and Log Inspection couldn't be enabled correctly when the system locale was set to Turkish. DS-48916
 - Integrity Monitoring events showed an incorrect file path with Unicode encoding. SEG-45239/DS-33911
 - The Windows Update procedure was blocked when Application Control was enabled in Block-Mode. SF02092464/SEG-53938/DS-38578
 - Deep Security Agent's Intrusion Prevention module silently dropped zero payload UDP packets. SEG-39711/DS-32799
 - For Web Reputation, Deep Security Agent sent the incorrect credentials to the proxy, which returned HTTP 407. SF01704358/SEG-45004/DS-32077
 - Deep Security's Notifier.exe process caused high CPU usage. SF01716752/SEG-45507/DS-33645
 - The "Smart Protection Server Disconnected for Smart Scan" alert did not automatically clear after the connection had been restored. SF1609675/SEG-43574/DS-32947
 - In some cases, the Windows driver did not correctly release spinlock, causing the system to hang. SF01990859/SEG-50709/DS-36066
 - Deep Security Agent process sometimes crashed when the detailed logging of SSL message was enabled and outputted. SF01745654/SEG-45832/DS-33007
 - When multiple Smart Protection Servers were configured, the Deep Security Agent process would sometimes crash due to an invalid sps_index. SF01415702/SEG-42919/DS-33008
 - The Send Policy action failed because of a GetDockerVersion error in Deep Security Agent. SF1939658/SEG-49191/DS-34222
 - Deep Security Agent sent invalid JSON objects in response to Deep Security Manager, which caused errors in Deep Security Manager's log file. SF01919585/SEG-48728/DS-34022
-

- The ds_agent process would sometimes crash under certain conditions when Integrity Monitoring was enabled. SEG-50728/DS-35446
 - The Deep Security Agent network engine crashed because the working packet object was deleted accidentally. SF01526046/SF02159742/SEG-55453/DS-38812
 - Deep Security Agent restarted abnormally along with an "Unable to send data to Notifier app." error message in ds_agent.log. SEG-21208/DS-33134/DS-21352
 - When the system region format is "Chinese (Traditional, Hong Kong SAR)", Deep Security Notifier displayed simplified Chinese instead of traditional Chinese. SEG-48075/DS-34778
 - Unicode user names could not be displayed in real-time Integrity Monitoring file scan events. SF02187371/SEG-56645/DS-39398
 - Deep Security Agent did not add Python extension module (PYD) files to the inventory of Application Control. SF01804378/SEG-47425/DS-33690
 - Too many file open events were being processed in user mode resulting in high CPU usage. SF02179544/SEG-55745/DS-39638
 - The Type attribute was not displayed in Integrity Monitoring events when the default STANDARD attribute was set to monitor registry value changes. SF02412251/SEG-59848/DS-41118
 - Non-executable files that were opened with execute permissions resulted in security events and drift that should not have been generated. SF01780211/SEG-46616/DSSEG-3607
 - High CPU use occurred when Application Control was enabled and the host application was creating a high volume of non-executable files. SF02179544/SEG-55745/DS-41142
 - The Windows Update procedure was blocked when Application Control was enabled in Block-Mode. SF02092464/SEG-53938/DS-39981
 - Deep Security failed to download security updates because of an outdated user agent string. SF02043400/SEG-52069/DS-41316
 - When machines wrote document files to a file server, Anti-Malware needed to scan the files frequently, which caused other machines to fail to write the file because the file was being scanned. SF01949194/SEG-49854/DS-40100
-

- When Deep Security Agent scanned large files for viruses, it consumed a large amount of memory. SF01572110/SEG-48704/DS-43114

Security updates

Security updates are included in this release. For more information about how Trend Micro protects against vulnerabilities, visit [Vulnerability Response](#). Note that in line with responsible disclosure practices, CVE details will only be made available for select security updates once patches have been made available for all impacted releases. VRTS-3704/VRTS-3176

Highest CVSS Score: 7.8

Highest severity: High

- Updated NGINX to 1.16.1. DSSEG-4600
- Updated to curl 7.67.0.
- Updated to openssl-1.0.2t.
- Updated JRE to the latest Java Update (8.0.241/8.43.0.6).

Known issues

- After upgrading the Deep Security Agent, the "Sending Application Control Ruleset Failed" error may occur. To work around this issue, right-click the affected computer and select **Actions > Clear Warnings/Errors**, then **Send Policy**.
- After upgrading the Deep Security Agent on Windows 2008, Anti-Malware may go offline. If this occurs, fully uninstall Deep Security Agent, reboot your server, then reinstall the agent.

Upgrade notice

- If you have Application Control enabled, there may be a temporary performance impact while your software inventory is automatically rebuilding. DS-41775

Unix

Deep Security Agent - 20.0.1-7380 (20 LTS Update 2024-04-24)

Release date: April 24, 2024

Build number: 20.0.1-7380

Enhancements

- Deep Security Agent now supports Trend Vision One Service Gateway exclusions. This is only supported for Trend Cloud One - Endpoint & Workload Security users at this time. V1E-17754
- Updated Deep Security Agent for AIX platforms to increase the pre-remove script timeout to 120 seconds. PCT-19843/DSA-4839

Resolved issues

- Deep Security Agents running in cloud environments sometimes could not be activated for Trend Cloud One - Endpoint & Workload Security. DSA-4861

Deep Security Agent - 20.0.1-4540 (20 LTS Update 2024-03-20)

Release date: March 20, 2024

Build number: 20.0.1-4540

This release contains general improvements.

Deep Security Agent - 20.0.1-3180 (20 LTS Update 2024-02-29)

Release date: February 29, 2024

Build number: 20.0.1-3180

Resolved issues

- Migration of agents from on-premise Deep Security Manager to Trend Cloud One - Endpoint & Workload Security using Trend Vision One Service Gateway failed. This issue could also occur when migrating using other proxy services. PCT-16649/DSA-4144

- Enabling Intrusion Prevention or Web Reputation Service in Deep Security Agent sometimes resulted in a TLS inspection process (tm_netagent) error log rotation issue. DSA-3965

Security updates

Security updates are included in this release. For more information about how Trend Micro protects against vulnerabilities, visit [Vulnerability Response](#). Note that in line with responsible disclosure practices, CVE details will only be made available for select security updates once patches have been made available for all impacted releases. VRTS-11708/DSA-3702

Highest CVSS score: 7.8

Highest severity: High

Known issues

- The Application Control Trust Entities "block by target" trust rule sometimes does not work properly when running a copy of an executable file. PCT-11105/DSA-3324

Deep Security Agent - 20.0.1-690 (20 LTS Update 2024-01-17)

Release date: January 17, 2024

Build number: 20.0.1-690

Enhancements

- From 2024 onward, Deep Security Agent versioning is being revised from 20.0.0 to 20.0.1. This requires Deep Security Manager 20.0.883 or later. DSA-3584.

For details, see [Platform support updates for Deep Security Agent \(DSA\) version revision in January 2024 Update Release](#).

Resolved issues

- Deep Security Agent was sometimes unable to connect to the local Smart Protection Server. DSA-3564

Known issues

- Updating to Deep Security Agent 20.0.1-690 from some 20.0.0 versions sometimes fails when using Deep Security Relay on Trend Cloud One - Endpoint & Workload Security. For details, see [Failed remote upgrade of self-deployed Workload Security relay from 20.0.0-3445 or later to version revision 20.0.1](#) DSA-3317

Deep Security Agent - 20.0.0-8438 (20 LTS Update 2023-12-12)

Release date: December 12, 2023

Build number: 20.0.0-8438

Resolved issues

- When using a local Smart Protection Server and a configured proxy, Web Reputation Service would sometimes improperly send traffic through the proxy. Web Reputation Service now sends queries to the local Smart Protection Server directly. DSA-2981

Security updates

Security updates are included in this release. For more information about how Trend Micro protects against vulnerabilities, visit [Vulnerability Response](#). Note that in line with responsible disclosure practices, CVE details will only be made available for select security updates once patches have been made available for all impacted releases. DSA-2722

Highest CVSS score: 9.8

Highest severity: Critical

Known issues

- Deep Security Agent is sometimes unable to connect to the local Smart Protection Server. This issue is fixed in 20.0.1-690. For details, see [Deep Security Agent \(DSA\) connection issues with Smart Protection Server \(SPS\) when using proxy](#) DSA-3564

Deep Security Agent - 20.0.0-8268 (20 LTS Update 2023-11-21)

Release date: November 21, 2023

Build number: 20.0.0-8268

Resolved issues

- Deep Security Anti-Malware sometimes did not function as expected after the system had resumed from sleep mode (S0 low-power idle mode of the working state, also known as modern standby). SF07326571/PCT-5476/DSA-2485
- Deep Security Agent incorrectly classified MIME type of `.xml` files generated by Microsoft Word, Excel, PowerPoint, as well as `.dwg` files generated by AutoCAD and R2000. SF07027236/SEG-186079/DSA-2202
- A memory leak would occur when loading large Suspicious Object lists. SF06904914/SEG-182231/DSA-1370

Deep Security Agent - 20.0.0-8137 (20 LTS Update 2023-10-26)

Release date: October 26, 2023

Build number: 20.0.0-8137

This release contains general improvements.

Deep Security Agent - 20.0.0-7943 (20 LTS Update 2023-09-26)

Release date: September 26, 2023

Build number: 20.0.0-7943

Enhancements

- New commands exist to get proxy information from the command line:
`dsa_query -c GetProxyInfo`
`dsa_query -c GetProxyInfo details=true`
DSA-864
- In order to display agent pattern updates properly, Deep Security Agent 20.0.0-7943 or later requires Deep Security Manager 20.0.759 or later. For more information, see [Incompatible Agent / Appliance Version error in Deep Security Agent 20.0.0-7943](#). SEG-190866/SEG-191017/DSA-1531

Deep Security Agent - 20.0.0-7719 (20 LTS Update 2023-08-29)

Release date: August 29, 2023

Build number: 20.0.0-7719

Enhancements

- Deep Security Agent no longer updates the Smart Scan agent pattern when Smart Scan is disabled, saving network bandwidth. SEG-186625/DSA-1063
- Deep Security Agent now downloads fewer incremental pattern updates, saving network bandwidth. Note that agents configured as a Deep Security Relay still download all pattern updates. DSA-1000
- The "blocking page" Web Reputation Service redirects users to when they try to access a blocked URL can now be viewed in Czech or Polish. DSA-444
- Intrusion Prevention can now limit how many bytes are scanned for connections with a dynamic port number between 10001-65535. DS-78036
- Advanced Threat Scan Engine version has been updated to 22.6. DSA-453

Resolved issues

- Stopping the Deep Security Agent service (ds_agent) took longer than usual on some systems. SEG-187365/DSA-1212
 - Deep Security Agent sometimes performed security updates even if none were scheduled. SEG-187449/DSA-1064
-

- Deep Security Agent caused high CPU usage on some systems. SEG-185563/DSA-756

Deep Security Agent - 20.0.0-7476 (20 LTS Update 2023-07-25)

Release date: July 25, 2023

Build number: 20.0.0-7476

Enhancements

- Updated the dsa-connect service to improve CPU performance. C1WS-12970

Resolved issues

- Deep Security Agent upgrades from 20.0.0.6313 to a newer version would sometimes fail, generating an "Abnormal Restart Detected" warning. SF06897730/SEG-180989/DS-78063

Deep Security Agent - 20.0.0-7303 (20 LTS Update 2023-06-28)

Release date: June 28, 2023

Build number: 20.0.0-7303

Enhancements

- Deep Security Agent now supports IPv6 addresses using either CIDR or double colon notation, such as fe80:0:0:0:0:0:1/24 or fe80::01. SF04849178/SEG-122076/DS-67280
 - Activity Monitoring events now display the FQDN instead of the hostname. SF06709374/SEG-179186/C1WS-14644
 - Web Reputation Service now automatically monitors the ports used by the [OS proxy](#) configuration. DS-77233
-

Resolved issues

- Deep Security Agents on AIX would sometimes crash when trying to upgrade to a new version. SF06643647/SEG-173140/DS-77359
- Intrusion Prevention (IPS) might not read the correct payload value, which can result in rule malfunctions. DS-74647
- The Deep Security Agent would report "dsa-connect has not provided status" on every heartbeat, even when Endpoint Sensor was not in use. C1WS-14696
- Some MQTT messages would be sent repeatedly and cause dsa-connect to get stuck in a shutdown loop. DS-76709

Deep Security Agent - 20.0.0-7119 (20 LTS Update 2023-05-29)

Release date: May 29, 2023

Build number: 20.0.0-7119

Enhancements

- Updated Deep Security Agent for Solaris to add an option to enable collecting interface latency metrics on Azure Data Explorer dashboards. DS-77025

Resolved issues

- MQTT connection credentials were entered in the Deep Security Agent log file (`ds_agent.log`) in certain scenarios. SEG-174560/C1WS-13282
- Deep Security Agent only reported a single Anti-Malware event for an infected compressed file, even if it contained multiple infected files. DS-76339
- After replacing a connection, Deep Security Agent reported metrics as though it was still connected to the old connection for up to 4 minutes. DS-77453

Deep Security Agent - 20.0.0-6912 (20 LTS Update 2023-05-02)

Release date: May 02, 2023

Build number: 20.0.0-6912

Enhancements

- Updated Deep Security Agent to make the connection timeout for proxy probing configurable by adding a line to `ds_agent.ini`. SF06664116/SEG-173848/DS-77182

Example proxy probing line in `ds_agent.ini` config file:

```
dsa.proxymanager.ProbeTimeoutInSec=120
```

- Updated Deep Security Agent to improve MQTT connection quality and reduce the occurrence of connection timeouts. DS-76840

Resolved issues

- Deep Security Agent sometimes reported the network driver status incorrectly after the driver had restarted. C1WS-12896
- When Web Reputation Service was enabled, Deep Security Agent caused some systems to shutdown unexpectedly. SF06680505/SEG-174730/DSSEG-7866
- Deep Security Agent sometimes crashed when shutting down after downloading new plugins from the relay. DS-76961

Deep Security Agent - 20.0.0-6658 (20 LTS Update 2023-03-22)

Release date: March 22, 2023

Build number: 20.0.0-6658

New features

Service Gateway: Deep Security Agent 20.0.0-6658 or later with Deep Security Manager 20.0.741 or later now supports the Service Gateway feature, providing forward proxy functionality.

Enhancements

- Web Reputation Service now includes OS platform metadata. DS-75453
- Updated Deep Security Agent's logging system to provide additional information and tracing to debug customer issues more efficiently. The agent now generates

five (5) log files (`dsa-connect-X.log`) that are 2MB each instead of the agent's previous three 1MB log files. C1WS-9598

The logger supports an on-demand JSON config file (either `dsa-connect.ini` or `dsa-connect.conf`) with the following configurable options:

- **Debug:** Enable the debug log messages. The default value is false.
- **Count:** Number of log files to generate. The default value is 5.
- **Size:** Maximum size of each log file in bytes. The default value is 2097152.

Example config file:

```
{
  "Debug": true,
  "Count": 5,
  "Size": 2097152
}
```

Resolved issues

- When the Advanced TLS Traffic Inspection "Inspect TLS/SSL traffic" option was set to "No" from the console (**Computer or Policy > Intrusion Prevention > General > Advanced TLS Traffic Inspection**), driver-side SSL packets were sometimes still being processed. DS-76160
- Deep Security Agent's Intrusion Prevention System sometimes failed to block "TCP Congestion Flags" properly. DS-76182
- When Anti-Malware Smart Scan was enabled, an IPC connectivity issue caused some systems to crash. SEG-169132/C1WS-10821
- Deep Security Agent security updates were failing due to a file handle issue that prevented files from being removed during an update. DS-75907
- A process thread timeout caused the Anti-Malware Engine to restart unexpectedly on some systems. SF06524736/SEG-169218/DS-76656
- When a SOCKS proxy was used, Deep Security Agent failed to provide a Web Reputation Services rating for HTTP URLs. DS-73482/DS-73364
- Deep Security Agent upgrade sometimes failed because of a missing signature in the agent package. SF06045259/SEG-154576/DS-73668

- Deep Security Agent was incorrectly generating system events showing that the Advanced Threat Search Engine (ATSE) component had been removed on some systems. SEG-147779/DS-75463
- Updated Deep Security Agent to increase the MQTT timeout from 30 minutes to 2 hours to help resolve connection issues on some systems. C1WS-11835

Deep Security Agent - 20.0.0-6313 (20 LTS Update 2023-01-31)

Release date: January 31, 2023

Build number: 20.0.0-6313

Enhancements

- Deep Security no longer supports certificates signed with the SHA-1 algorithm. The agent now requires SSL certificates issued using SHA-256 to communicate with the Deep Security Manager. C1WS-5676

Warning: To prevent communication errors between the Deep Security Agent and Deep Security Manager, follow the instructions to [Upgrade the Deep Security cryptographic algorithm](#).

If you updated to Deep Security Agent 20.0.0-6313 or later before upgrading the cryptographic algorithms, follow the steps in [Deep Security Agent \(DSA\) offline when OpenSSL 3 rejects certificate with SHA-1 algorithm](#).

Resolved issues

- Updated Deep Security Agent for AIX platforms to support Advanced Threat Scan Engine (ATSE) version 21.600. DS-75323
- For component updates, Deep Security Agent would attempt with and without use of a proxy and generate an event for each attempt. To make event reporting more straightforward, this behavior has been changed so that after a successful update the agent only shows the final successful event. SF06207160/SEG-160085/DSSEG-7765

- The Deep Security Agent log file (`ds-agent.log`) sometimes failed to rotate, causing it to use more disk space than intended. SF05306459/SEG-137003/DS-72899
- With Web Reputation Enabled, some characters entered in console commands were not being parsed properly. For example, an underscore (`_`) entered in a command was replaced with a dash (`-`), and an uppercase Z was replaced with a lowercase z. DS-74335

Deep Security Agent - 20.0.0-5953 (20 LTS Update 2022-11-22)

Release date: November 22, 2022

Build number: 20.0.0-5953

This release contains general improvements. **Note that this release only includes an agent for Solaris platforms.**

Deep Security Agent - 20.0.0-5761 (20 LTS Update 2022-10-21)

Release date: October 21, 2022

Build number: 20.0.0-5761

Enhancements

- Updated Deep Security Agent to include additional metadata, such as `UserAgent` and `Referrer`, for Web Reputation Services. DS-72196
- Updated Deep Security Agent to include the Integrity Monitoring database in the agent diagnostic package. DS-73293
- Updated Deep Security Agent to support NULL cipher when inspecting TLS traffic with Intrusion Prevention. DS-71085

Resolved issues

- With Log Inspection enabled, Deep Security Agent sometimes generated "Abnormal Restart Detected" events. SF05951130/SEG-151372/DS-73737
- Virtual Machines using vMotion sometimes deactivated unexpectedly and displayed an Offline (Activation required) status. SEG-153050/DS-73807

Deep Security Agent - 20.0.0-5512 (20 LTS Update 2022-09-22)

Release date: September 22, 2022

Build number: 20.0.0-5512

Enhancements

- Updated Deep Security Agent to add multi-thread support for On-Demand scan and Scheduled Scan. DS-72797/DS-72798

Resolved issues

- Deep Security Agent reported host metadata in an unexpected format. DS-73411

Security updates

Security updates are included in this release. For more information about how Trend Micro protects against vulnerabilities, visit [Vulnerability Response](#). Note that in line with responsible disclosure practices, CVE details will only be made available for select security updates once patches have been made available for all impacted releases. VRTS-8100/VRTS-8101/DS-73087/DS-72528

Highest CVSS score: 7.0

Highest severity: High

Deep Security Agent - 20.0.0-5394 (20 LTS Update 2022-08-29)

Release date: August 29, 2022

Build number: 20.0.0-5394

New features

AIX7.3 support: Deep Security Agent 20.0.0-5394 or later with Deep Security Manager 20.0.677 or later now supports AIX 7.3.

Enhancements

- Application Control now detects software changes for executables with non executable extensions. DS-70805
- Updated Deep Security Agent to add support for inspecting packets using dynamic ports in a TLS connection. DS-71078
- Updated Deep Security Agent to add more metrics for Advanced TLS Inspection. DS-72833

Resolved issues

- When TLS inspection was done on a UDP connection with dynamic ports, the operating system would sometimes crash. SEG-151169/DS-73043
- Log Inspection Engine would go offline when using '\$' character in match or regex fields together with variables. SEG-146965/SEG-146966/DS-72325
- When assigning a policy with real-time Anti-Malware turned off to a new guest VM, it would sometimes turn off real-time Anti-Malware for all other guest VMs registered to the same Deep Security Virtual Appliance. SEG-146057/DS-72856
- Application Control would still block access to network files while in maintenance mode. SF04922652/SEG-131710/DS-72037
- When Application Control is enabled, Adobe plugins were generating unexpected security events. SF05823607/SEG-148570/DS-72679
- Deep Security Agent would return "revision mismatch (-10039)" errors when loading certain configuration files during an agent update. DS-72499
- Deep Security Agent would report detected software changes before Application Control inventory scan was completed. DS-72071

Known issues

- When executing multiple custom script tasks, new tasks are currently overwritten by previous unfinished tasks. You can execute custom script tasks one by one to bypass this issue. Note that this issue will be fixed in a future release. DS-72699

Deep Security Agent - 20.0.0-5137 (20 LTS Update 2022-07-26)

Release date: July 26, 2022

Build number: 20.0.0-5137

Enhancements

- Updated Deep Security Agent to improve Trust Entities functionality. Trust rule wildcard support now includes globstar `**` which matches many sub directories. Single star `*` now only matches within your current directory. Existing rules that used a single star `*` to match many folders no longer work and need to be changed to use a globstar `**`. DS-71817

Resolved issues

- Intrusion Prevention rules with certain setting combinations failed to compile. DS-71889

Security updates

Security updates are included in this release. For more information about how Trend Micro protects against vulnerabilities, visit [Vulnerability Response](#). Note that in line with responsible disclosure practices, CVE details will only be made available for select security updates once patches have been made available for all impacted releases. VRTS-7102/VRTS-7070/VRTS-7041/VRTS-7039/DSSEG-7636

Highest CVSS score: 4.4

Highest severity: Medium

Known issues

- When executing multiple custom script tasks, new tasks are currently overwritten by previous unfinished tasks. You can execute custom script tasks one by one to bypass this issue. Note that this issue will be fixed in a future release. DS-72699

Deep Security Agent - 20.0.0-4959 (20 LTS Update 2022-07-04)

Release date: July 4, 2022

Build number: 20.0.0-4959

Resolved issues

- With Log Inspection enabled, upgrades to Deep Security Agent 20.0.0-4726 encountered "Get Events Failed" and "Command Not Found" alerts. SF05738607/SEG-145679/DS-72117
- When Anti-Malware is enabled alongside either Integrity Monitoring or Activity Monitoring, Deep Security Agent caused high CPU usage. SF05169148/SEG-129522/DS-69594
- With Anti-Malware enabled, Deep Security Agent sometimes crashed operating systems that were undergoing an ISO backup. SF05532786/SEG-139280/DS-71299
- Deep Security Agent sometimes created unclear error log entries referencing "invalid" or "badly-formed" proxy URLs. SEG-144613/DS-71866

Deep Security Agent - 20.0.0-4726 (20 LTS Update 2022-05-31)

Release date: May 31, 2022

Build number: 20.0.0-4726

Resolved issues

- On AIX servers, when the `LIBPATH` or `LD_LIBRARY_PATH` environment variables for the system are defined, Deep Security Agent sometimes would not start. DS-70882
- Deep Security Agent reported false positive "Created/Deleted" Integrity Monitoring events under some configurations. SF05434164/SEG-136425/DS-70656
- Deep Security Agent had connectivity issues caused when a Server Name Indicator (SNI) used an invalid format. SEG-127761/DS-70806
- An abnormal restart of Deep Security Agent sometimes lead to "Anti-Malware Engine Offline" errors. SEG-140234/DS-71333

Security updates

Security updates are included in this release. For more information about how Trend Micro protects against vulnerabilities, visit [Vulnerability Response](#). Note that in line with responsible disclosure practices, CVE details will only be made available for select

security updates once patches have been made available for all impacted releases. DS-52329

Highest CVSS score: 7.5

Highest severity: High

Deep Security Agent - 20.0.0-4416 (20 LTS Update 2022-04-28)

Release date: April 28, 2022

Build number: 20.0.0-4416

Enhancements

- Updated Deep Security Agent to improve Intrusion Prevention performance when the "Bypass Network Scanner" rule was applied. DS-69515

Resolved issues

- With Intrusion Prevention enabled, a packet transmission error caused some systems to crash. SEG-136843/DSSEG-7524

Security updates

Security updates are included in this release. For more information about how Trend Micro protects against vulnerabilities, visit [Vulnerability Response](#). Note that in line with responsible disclosure practices, CVE details will only be made available for select security updates once patches have been made available for all impacted releases. VRTS-7132/DS-70518

Highest CVSS score: 7.5

Highest severity: High

Deep Security Agent - 20.0.0-4185 (20 LTS Update 2022-04-06)

Release date: April 6, 2022

Build number: 20.0.0-4185

Resolved issues

- Running an Anti-Malware manual scan using the command line sometimes made Deep Security Agent unable to receive incoming connections. SF05385865/SEG-135256/DS-70364
- Application Control sometimes blocked unrecognized software even when running in maintenance mode. SF05234969/SEG-133594/DS-69752
- Log Inspection was unable to parse system logs containing a single digit date format. SF04562942/SEG-115435/DS-69757

Deep Security Agent - 20.0.0-3964 (20 LTS Update 2022-03-01)

Release date: March 1, 2022

Build number: 20.0.0-3964

New features

Threat Intelligence: Threat Intelligence (formerly known as Connected Threat Defense) provides enhanced malware protection for new and emerging threats. For more information, visit [Detect emerging threats using Threat Intelligence](#).

Enhancements

- Updated Deep Security Agent to exclude suspicious characters, such as \$, found in strings from the "Original IP (XFF)" field for Intrusion Prevention events. SEG-129905/DS-68989

Deep Security Agent - 20.0.0-3770 (20 LTS Update 2022-01-24)

Release date: January 24, 2022

Build number: 20.0.0-3770

Enhancements

- Updated Deep Security Agent to allow Intrusion Prevention to connect to Deep Security Manager if the manager is using TLS 1.2 strong ciphers. DS-69042

Resolved issues

- Application Control, Anti-Malware, and Real-time Integrity Monitoring failed to function properly for Deep Security Agents with certain combinations of Integrity Monitoring rules configured. DS-68494

Security updates

Security updates are included in this release. For more information about how Trend Micro protects against vulnerabilities, visit [Vulnerability Response](#). Note that in line with responsible disclosure practices, CVE details will only be made available for select security updates once patches have been made available for all impacted releases. DS-68180

Highest CVSS score: 9.1

Highest severity: High

Deep Security Agent - 20.0.0-3445 (20 LTS Update 2021-11-24)

Release date: November 24, 2021

Build number: 20.0.0-3445

Enhancements

- Updated Deep Security Agent to use TLS 1.2 strong cipher suite by default to improve security. The agent previously used the CBC cipher suite by default. DS-67204
- Updated Deep Security Agent to support using the "process name" property in "Ignore from source" rules for [Application Control Trust Entities](#) on Cloud One Workload Security. DS-67322
- Updated Deep Security Agent's database size management to optimize disk space usage. DS-67347

Resolved issues

- Deep Security Agent sometimes crashed when it could not connect to Deep Security Manager. DS-67654

- Deep Security Agent sometimes caused connectivity issues, high CPU usage, or the system to crash. SEG-120758/SEG-123885/DS-67291

Security updates

Security updates are included in this release. For more information about how Trend Micro protects against vulnerabilities, visit [Vulnerability Response](#). Note that in line with responsible disclosure practices, CVE details will only be made available for select security updates once patches have been made available for all impacted releases. VRTS-6489/DSSEG-7210/DS-65113

Highest CVSS score: 7.8

Highest severity: High

Deep Security Agent - 20.0.0-3288 (20 LTS Update 2021-10-28)

Release date: October 28, 2021

Build number: 20.0.0-3288

New features

- **Evolution of the agent installer:** The Deep Security Agent installer now installs most agent content. This results in the following changes:
 - Agent size requirements have increased, including a slightly larger installer package on most platforms.
 - All agent content is now installed on the computer being protected. Content remains unloaded on a computer until a plug-in is activated by a policy or by the manager console.
 - The agent is now much less dependent on relays because all plug-in installations use the content already installed with the agent. This mitigates plug-in install issues due to relay communications because plug-ins can be installed without a connection to a relay.
-

Resolved issues

- Deep Security Agent sometimes was unable to connect to the manager via proxies. DS-65929
- Some customers encountered an issue when the run-time CPU number was larger than expected, which led to crashes. DS-65757
- Deep Security Agent sometimes showed package signature errors during an upgrade because of a mismatched Certification Revocation List (CRL). DS-65056

Security updates

Security updates are included in this release. For more information about how Trend Micro protects against vulnerabilities, visit [Vulnerability Response](#). Note that in line with responsible disclosure practices, CVE details will only be made available for select security updates once patches have been made available for all impacted releases. DS-46018/DSSEG-7210/DSSEG-7217

Highest CVSS score: 7.8

Highest severity: High

Deep Security Agent - 20.0.0-3165 (20 LTS Update 2021-10-08)

Release date: October 08, 2021

Build number: 20.0.0-3165

Note: Deep Security Agent 20.0.0.3165 has been released to Trend Micro Cloud One - Workload Security customers. However, it is not available on the Deep Security Agent software download page or released to customers using Deep Security Manager.

New features

- **Evolution of the agent installer:** The Deep Security Agent installer now installs most agent content. This results in the following changes:
 - Agent size requirements have increased, including a slightly larger installer package on most platforms.

- All agent content is now installed on the computer being protected. Content remains unloaded on a computer until a plug-in is activated by a policy or by the manager console.
- The agent is now much less dependent on relays because all plug-in installations use the content already installed with the agent. This mitigates plug-in install issues due to relay communications because plug-ins can be installed without a connection to a relay.

Resolved issues

- Deep Security Agent sometimes was unable to connect to Manager via proxies. DS-65929
- Some customers encountered an issue when the run-time CPU number was larger than expected, led to crashes. DS-65757

Security updates

Security updates are included in this release. For more information about how Trend Micro protects against vulnerabilities, visit [Vulnerability Response](#). Note that in line with responsible disclosure practices, CVE details will only be made available for select security updates once patches have been made available for all impacted releases. DSSEG-7210/DSSEG-7217

Highest CVSS score: 7.8

Highest severity: High

Deep Security Agent - 20.0.0-2921 (20 LTS Update 2021-08-30)

Release date: August 30, 2021

Build number: 20.0.0-2921

Resolved issues

- Deep Security Agent console commands sometimes failed to return proxy information for Deep Security Relay or Deep Security Manager. DS-65419

- Deep Security Agent sometimes failed to properly display items under **Events and Reports**. DSSEG-7057

Deep Security Agent - 20.0.0-2740 (20 LTS Update 2021-07-29)

Release date: July 29, 2021

Build number: 20.0.0-2740

Enhancements

- Updated Deep Security Agent to improve connectivity with Deep Security Manager during agent deployment and activation. DS-62547

Resolved issues

- Deep Security Agent failed to execute some agent-initiated (dsa_control) console commands. 04564385/SEG-112050/DSSEG-6990
- Deep Security Agent sometimes crashed while trying to establish a connection with Deep Security Manager. 04634804/SEG-113539/DS-64862
- Deep Security Agent sometimes lost connectivity while trying to establish an SSL connection. SF04323898/SEG-107451/DS-64268
- Deep Security Agent was sometimes unable to connect to web applications on systems with older OS versions. SF04451029/SEG-109652/DS-64528
- With Web Reputation enabled, Deep Security Agent caused connectivity issues for some third-party software. SF04072723/SEG-97952/DSSEG-6963
- With Integrity Monitoring enabled, Deep Security Manager caused high CPU usage on the authentication server for some systems. 04488319/SEG-110088/DS-63855

Security updates

Security updates are included in this release. For more information about how Trend Micro protects against vulnerabilities, visit [Vulnerability Response](#). Note that in line with responsible disclosure practices, CVE details will only be made available for select security updates once patches have been made available for all impacted releases. SF04613197/SEG-113566/DS-64050

Highest CVSS score: 9.8

Highest severity: High

Deep Security Agent - 20.0.0-2593 (20 LTS Update 2021-07-01)

Release date: July 01, 2021

Build number: 20.0.0-2593

Resolved issues

- Deep Security Agent sometimes triggered multiple "Log Inspection Engine Initialized" alerts due to an agent-manager communication issue. SF03968169/SEG-95731/DS-60840
- Integrity Monitoring alerts sometimes triggered but did not appear in the **Events and Reports** tab. 04266346/SEG-103731/DS-62992
- Deep Security Agent failed to detect the correct platform under some configurations. 03804296/SEG-90864/DS-57809
- Application Control was detecting multiple "Application Control Software Changes Detected" events due to ".tmp" files being generated by PowerShell. C1WS-1608

Security updates

Security updates are included in this release. For more information about how Trend Micro protects against vulnerabilities, visit [Vulnerability Response](#). Note that in line with responsible disclosure practices, CVE details will only be made available for select security updates once patches have been made available for all impacted releases. VRTS-5850/DS-54705

Highest CVSS score: 4.4

Highest severity: Medium

Deep Security Agent - 20.0.0-2395 (20 LTS Update 2021-05-24)

Release date: May 24, 2021

Build number: 20.0.0-2395

Enhancement

- Deep Security Agent 20.0.0-2395 or later now supports Entrust Root Certificate Authority (G2) certificates. Non-G2 security certificates expire on 2022/07/09. After that date, only Deep Security Agent 20.0.0-2395 or later will have the latest Anti-Malware Smart Scan protection. DS-63010

Resolved issues

- Deep Security Agent sometimes showed package signature errors during an upgrade because of a mismatched Certification Revocation List (CRL). DS-62154

Deep Security Agent - 20.0.0-2204 (20 LTS Update 2021-04-12)

Release date: April 12, 2021

Build number: 20.0.0-2204

New feature

Enhanced platform support

- Anti-Malware support for AIX: Deep Security Agent 20.0.0-2204 or later now supports Anti-Malware for AIX 6.1, AIX 7.1, and AIX 7.2.

Resolved issues

- With Anti-Malware enabled, Deep Security Agent sometimes caused "defunct processes" (that is, processes that remain in the system process table after they've completed execution). SEG-104452/DS-61593
- When Application Control was in block mode, it was unable to build a proper software inventory in some cases. DS-58813
- When Web Reputation was enabled, the system sometimes crashed. SF04258834/SEG-102756/DS-61067

Deep Security Agent - 20.0.0-2009 (20 LTS Update 2021-03-08)

Release date: March 08, 2021

Build number: 20.0.0-2009

Resolved issues

- The MQTT connection went offline because an old MQTT connection was not properly cleaned. SF04236908/SEG-102056/DS-60893

Deep Security Agent - 20.0.0-1876 (20 LTS Update 2021-02-08)

Release date: February 08, 2021

Build number: 20.0.0-1876

Resolved issues

- Activity Monitoring data could not be transferred to XDR because a proxy connection was established without a relevant port. SEG-97519

Deep Security Agent - 20.0.0-1822 (20 LTS Update 2021-01-18)

Release date: January 20, 2021

Build number: 20.0.0-1822

New feature

Anti-Malware support for AIX: Deep Security Agent 20.0.0-1822 or later now supports Anti-Malware for AIX 7.1 and 7.2.

Deep Security Agent - 20.0.0-1681 (20 LTS Update 2021-01-04)

Release date: January 04, 2021

Build number: 20.0.0-1681

This release contains general improvements.

Deep Security Agent 20.0.0-1559 (20 LTS Update 2020-12-07)

Release date: December 07, 2020

Build number: 20.0.0-1559

New features

TLS Directionality: The manager heartbeat port can now act as both a TLS client and TLS server. Future agents will connect as TLS clients, not TLS servers. This resolves issues with agent-initiated connections through a proxy or firewall that requires TLS sessions to be initiated in the same direction as the TCP layer of the connection.

Enhancements

- Improved Deep Security Relay's performance by only checking packages that have been modified. DS-55527
- Improved Deep Security Agent to better support Activity Monitoring on Trend Micro Cloud One - Workload Security. For more information, see [Enable Activity Monitoring](#). DS-55230
- Enhanced memory usage to improve performance. DS-53012

Resolved issues

- On Solaris servers where Integrity Monitoring was enabled and the rule: "Unix - Monitor Processes Running From '/tmp' Directories (ATT&CK T1059)" was assigned, a rule compile error was generated that referenced an "Unsupported Feature in Integrity Monitoring Rule". DS-55884
- When Integrity Monitoring was enabled, a high amount of CPU was used. SEG-88619/03720485/DS-56613
- Application Control events occurred multiple times for the same incident. SEG-86213/SF03620055/DS-57298
- Security updates were not automatically performed on new machines. SEG-91484/SF03828068/DS-57688

Notice

In this agent update there is a change to how the validation of the TLS certificate used for agent-manager communication is implemented. If you see the following warning during agent activation:

```
[Warning/2] | SSLVerifyCallback() - verify error 20: unable to get local issuer certificate
```

The most likely root cause is that agent cannot validate the certificate being presented to it by the manager. Pinning a trusted certificate is optional, so you can ignore this error if it doesn't apply to you. However, if you'd like to use a trusted certificate, follow the steps in ["Import a Deep Security Manager certificate chain issued by a public CA" on page 1569](#) before activating the Deep Security Agent.

Deep Security Agent 20.0.0-1337 (20 LTS Update 2020-10-28)

Release date: October 28, 2020

Build number: 20.0.0.1337

Resolved issues

- When using Deep Security Agent on Solaris, the Integrity Monitoring port scanning feature did not work because the agent did not have access to information on the user ID under which a given port was opened. This prevented storage of any listening port information. The port scanning feature on Solaris agents has been modified to store the string "n/a" for the userid. This allows the remaining port information to be stored and used in the port scanning function. However, exclusions and inclusions based on User ID still do not function correctly because this information is not available. DS-53922

Deep Security Agent 20.0.0-1304 (20 LTS Update 2020-10-21)

Release date: October 21, 2020

Build number: 20.0.0.1304

Enhancements

- Updated the Integrity Monitoring scan completion time in Deep Security Manager events to display in seconds with a thousands separator. DS-54680

Resolved issues

- Deep Security Manager reported a security update timeout because Deep Security Agent received exceptions at security updates. SEG-82072/DS-54720
- Deep Security Manager sometimes showed the incorrect Log Inspection status. SEG-77081/DS-54719

Deep Security Agent 20.0.0-1194 (20 LTS Update 2020-10-05)

Release date: October 5, 2020

Build number: 20.0.0.1194

Enhancements

- Extended the scope of the "If a computer with the same name already exists" setting on **Administration > System Settings > Agents** to apply to existing unactivated computers. Previously, it only applied to existing activated computers. DS-51800
- Integrity Monitoring detects changes to the "setuid" and "setgid" attributes for Linux and Unix platforms. DS-52061

Resolved issues

- Anti-Malware directory exclusion with wildcards didn't match subdirectories correctly. DS-50245
- Deep Security Agent crashed on Solaris 10 during upgrades. SEG-72634/SF02975849/DS-49295
- When Integrity Monitoring was enabled, the owner of a file was incorrectly changed to a user that did not exist. DS-52058

Security updates

Security updates are included in this release. For more information about how Trend Micro protects against vulnerabilities, visit [Vulnerability Response](#). Note that in line with responsible disclosure practices, CVE details will only be made available for select

security updates once patches have been made available for all impacted releases.
VRTS-3704/DS-41233

Highest CVSS Score: 4.4

Highest severity: Medium

Deep Security Agent 20 (long-term support release)

Release date: July 30, 2020

Build number: 20.0.0.877

New features

Improved security

SSL improvements: Deep Security supports handshake hello_request (rfc5246) and Extension encrypt_then_mac (rfc7366) in SSL inspection.

Agent integrity check: Deep Security verifies your signature on the Deep Security Agent to ensure that the software files have not changed since the time of signing.

Improved quality and management

Upgrade to supported paths: The Upgrade on activation feature only upgrades the agent on the computer from the last two major releases. If the agent does not meet the criteria, you must upgrade the agent manually to a release within the last two major releases. Then the Upgrade on activation feature will detect the newer version and complete the upgrade to the designated release.

Actionable recommendations for scan failures: The Deep Security Agent provides actionable information about why a scheduled malware scan has been canceled, and the recommended actions that should be taken to remedy the failure. For more information, see ["Anti-Malware scan failures and cancellations" on page 1133](#).

Anti-Malware real-time file scan report: Deep Security has the ability to determine the top 10 files that are scanned by Anti-Malware real-time scan. This provides a starting point for performance evaluating and tuning, as you can use this information to set file exclusions and avoid unnecessary scans. The 'AmTopNScan.txt' file with the collected data can be generated using the following methods:

- By the command `dsa_control --AmTopNScan`
- By the diagnostic service

Improved process exceptions: The process exception experience has been improved in the following ways:

- Information about why process exclusion items are not functioning correctly is now provided, so you can troubleshoot the issue and know which actions to take to resolve it.
- The process exception configuration workflow has been improved to make it more robust.

Automate the upgrade of agents in your environment: Deep Security gives you the flexibility to decide if new agents, when activated, should be upgraded to a newer version if one is available. This can be particularly useful in cases where application teams are using older golden images containing a version of the agent that is out of date. Simply enable upgrade on activation, define the lineup of agents you want to use in your environment using Agent Version Control, and as older agents come online and activate they are automatically upgraded for you.

Enhancements

- Integrity Monitoring detects changes to the "setuid" and "setgid" attributes for Linux and Unix platforms.
 - Improved the heartbeat handling for Amazon WorkSpaces deployments when the workspace sync feature is not turned on for the matching AWS connector.
 - Extended the scope of the **If a computer with the same name already exists** setting on **Administration > System Settings > Agents** to apply to existing unactivated computers. Previously, it only applied to existing activated computers.
 - Increased the scan engine's URI path length limitation.
 - Added the ability for Deep Security Agent Anti-Malware to scan compressed files no matter their data types when IntelliScan is disabled.
 - Streamlined event management for improved agent performance.
 - Added the ability to enable or disable Common Scan Cache for each agent through a CLI command.
-

- Added the ability for Deep Security Agent Anti-Malware to scan compressed files no matter their data types when IntelliScan is disabled.

Resolved issues

- After upgrading the Deep Security Agent, the "Sending Application Control Ruleset Failed" error sometimes occurred. DS-49828
- Application Control occasionally appeared offline when Application Control and Anti-Malware were enabled at the same time.
- The displayed packet header data contained redundant payload data. DS-45792
- Memory leaked during SSL decryption because of a flaw in the SSL processing. SEG-68263/DS-44360
- On specific Deep Security Agent servers the CPU usage spiked to 100% and pattern merges failed during the active update process. SEG-66210/02711299/DS-46429
- When a security update was triggered before Anti-Malware was ready, the security updates failed. DS-36952
- When real-time Integrity Monitoring was enabled with the rule "1002875: Unix Add/Remove Software" applied, the RPM database potentially locked. SEG-67275/SF02663756/DS-48524
- Web Reputation, Firewall, Intrusion Prevention, and Log Inspection couldn't be enabled correctly when the system locale was set to Turkish. SEG-71825/SF03021819/DS-48916
- Incorrect linking of certain libraries could lead to Deep Security Agent instability. SEG-72958/03071960/DS-49324
- Anti-Malware directory exclusion with wildcard didn't match subdirectories correctly. SF03131855/SEG-74892/DS-50245
- High CPU use occurred when Application Control was enabled and the host application was creating a high volume of non-executable files. SF02179544/SEG-55745/DS-41142
- Non-executable files that were opened with execute permissions resulted in security events and drift that should not have been generated. SF01780211/SEG-46616/DSSEG-3607

- Deep Security Agent did not add Python extension module (PYD) files to the inventory of Application Control. SF01804378/SEG-47425/DS-33690
- Unicode user names could not be displayed in real-time Integrity Monitoring file scan events. SF02187371/SEG-56645/DS-39398
- The Deep Security Agent network engine crashed because the working packet object was deleted accidentally. SF01526046/SF02159742/SEG-55453/DS-38812
- The ds_agent process would sometimes crash under certain conditions when Integrity Monitoring was enabled. SEG-50728/DS-35446
- Deep Security Agent sent invalid JSON objects in response to Deep Security Manager, which caused errors in Deep Security Manager's log file. SF01919585/SEG-48728/DS-34022
- The "Send Policy" action failed because of a GetDockerVersion error in Deep Security Agent. SF1939658/SEG-49191/DS-34222
- When multiple Smart Protection Servers were configured, the Deep Security Agent process would sometimes crash due to an invalid sps_index. SF01415702/SEG-42919/DS-33008
- For Web Reputation, Deep Security Agent sent the incorrect credentials to the proxy, which returned HTTP 407. (SF01704358/SEG-45004/DS-32077)
- Deep Security Agent's Intrusion Prevention module silently dropped zero payload UDP packets. SEG-39711/DS-32799
- Integrity Monitoring events showed an incorrect file path with Unicode encoding. SEG-45239/DS-33911
- The interface isolation feature was still on when Firewall was turned off. SEG-32926/DS-27099
- After applying rule 1006540, "Enable X-Forwarded-For HTTP Header Logging", Deep Security would extract the X-Forwarded-For header for Intrusion Prevention events correctly. However, a URL intrusion like "Invalid Traversal" would be detected in the HTTP request string before the header was parsed. The Intrusion Prevention engine has been enhanced to search X-Forwarded-For header after the header is parsed. SEG-60728/DS-42332

- Deep Security Agent sent invalid JSON objects in response to Deep Security Manager, which caused errors in Deep Security Manager's log file. SEG-48728/SF01919585/DS-34022
- On Solaris servers with clusters, the Deep Security Intrusion Prevention module would come under heavy load while inspecting the clusters' private traffic. The extra load caused latency issues, node evictions, and loss of synchronization events.

You can now configure the Packet Processing Engine on the agent to bypass traffic inspection on a specified interface. Where a specific interface on a computer is dedicated to cluster private traffic, this configuration can be used to bypass inspection of packets sent to and received from this interface. This results in faster packet processing on the bypassed interface and other interfaces.

Use of this configuration to bypass traffic inspection is a security risk. It is up to you to determine if the benefit of reduced latency outweighs the risk involved. It is also up to you to determine whether only the nodes in the cluster have access to the subnet whose interface is being bypassed.

To implement the bypass, do the following:

1. Upgrade the Deep Security Agent to the latest build containing this fix.
2. Create a file under /etc directory named "ds_filter.conf".
3. Open the /etc/ds_filter.conf file.
4. Add the MAC addresses of all NIC cards used for cluster communication, as follows:

```
MAC_EXCLUSIVE_LIST=XX:XX:XX:XX:XX,XX:XX:XX:XX:XX
```

5. Save.
6. Wait 60 seconds for your changes to take effect.

In the /etc/ds_filter.conf file:

- The MAC_EXCLUSIVE_LIST line must be the first line in the file.
- All letters in the MAC address must be uppercase.
- Leading zeros in each byte must be included.

Valid MAC_EXCLUSIVE_LIST:

```
MAC_EXCLUSIVE_LIST=0B:3A;12:F8:32:5E
```

```
MAC_EXCLUSIVE_LIST=0B:3A;12:F8:32:5E,6A:23:F0:0F:AB:34
```

Invalid MAC_EXCLUSIVE_LIST:

```
MAC_EXCLUSIVE_LIST=B:3A;12:F8:32:5E
```

```
MAC_EXCLUSIVE_LIST=0b:3a;12:F8:32:5e,6a:23:F0:0F:ab:34
```

```
MAC_EXCLUSIVE_LIST=0B:3A;12:F8:32:5E
```

If the MAC address is not valid, the interface is not bypassed. If the exact string "MAC_EXCLUSIVE_LIST=" is not present at the beginning of the line, no interfaces are bypassed. DSSEG-4055

Security updates

Security updates are included in this release. For more information about how Trend Micro protects against vulnerabilities, visit [Vulnerability Response](#). Note that in line with responsible disclosure practices, CVE details will only be made available for select security updates once patches have been made available for all impacted releases. VRTS-3704/VRTS-3176

Highest CVSS Score: 7.8

Highest severity: High

- Updated NGINX to 1.16.1. DSSEG-4600
- Updated to curl 7.67.0.
- Updated to openssl-1.0.2t.
- Updated JRE to the latest Java Update (8.0.241/8.43.0.6).

[macOS \(supported for Cloud One Workload Security only\)](#)

What's new in Deep Security Virtual Appliance?

Release date: July 30, 2020

Build number: 20.0.0.877

The Deep Security Virtual Appliance will reach [end of extended support \(EOL\)](#) on 31-Dec-2027 or VMware's end of support date for NSX-4.X, whichever comes first.

New features

Improved security

Support for protection features on NSX-T: Recommendation scans, Intrusion Prevention reconnaissance scans and Integrity Monitoring are enabled for NSX-T environments.

Seamless Anti-Malware protection on Deep Security Virtual Appliance: After migrating guest VMs to another ESXi host in the same cluster using vMotion, the Deep Security Virtual Appliance's network scans and Anti-Malware scans will now continue where they left off, without delay. This feature only applies if you are using NSX-T Data Center and guest machines are using a policy without network feature overrides.

Protect VMs in NSX-T environments: We have integrated the latest VMware Service Insertion and Guest Introspection technologies which enables you to protect your guest VMs using Intrusion Prevention, Web Reputation, Firewall, Integrity Monitoring and recommendation scans on NSX-T hosts with agentless protection.

Improved management and quality

NSX-T Network Throughput improvement: By introducing the Data Plane Development Kit (DPDK), we've made the network throughput three times faster when compared with prior technology.

Enhancements

- Improved the time it takes to auto-activate guest VMs protected by the Deep Security Virtual Appliance in an NSX-T environment.
- Added the "VMware NSX Policy Configuration Conflict" system event. This event is generated when Deep Security Manager detects that a NSX-T group is configured with different security policies for Endpoint Protection and Network Introspection (E-W).
- Updated Deep Security Manager to allow vCloud accounts to be added even if the virtual machine hardware information is missing.
- Extended the scope of the "If a computer with the same name already exists" setting on **Administration > System Settings > Agents** to apply to existing unactivated computers. Previously, it only applied to existing activated computers.
- When you upgrade the Deep Security Virtual Appliance SVM in NSX-T Manager, Deep Security Manager will now detect that a new SVM is now protecting guest VMs, and will auto-activate those VMs after the upgrade.

- Upgraded the vCloud Connector in Deep Security Manager supports vCloud 9.7 and vCloud 10.0.
- Added the ability to sync Deep Security Manager policies to NSX-T environments.
- Improved the experience when deleting vCenter Connectors with NSX-T Manager. Previously, you had to manually remove the NSX-T component as a service profile, endpoint rules and service deployments, or the vCenter deletion would fail.

Resolves issues

- Deep Security Virtual Appliance sometimes went offline. SEG-53294
- The Anti-Malware engine on Deep Security Virtual Appliance went offline when the signer field in the Census server reply was empty. SEG-73047
- When a guest VM was migrated between ESXi hosts frequently (using vMotion), sometimes the VM couldn't save the state file. This caused the guest to lose the protection of the Deep Security Virtual Appliance for several minutes after migration, until the VM was reactivated by Deep Security Manager automatically under the new ESXi server. (DSSEG-4341/DS-38221)
- The Deep Security Virtual Appliance did not detect an Eicar file. SEG-71955/SF02955546/DS-49387

Known issues

- The automatic removal of a vCenter account from Deep Security will fail if NSX-T is configured to have the same service chain bound to Deep Security and third-party services simultaneously. This problem occurs because the NSX-T API doesn't allow Deep Security to modify the service chain with its associated service profiles. To work around this issue, remove vCenter manually. For details, see ["Uninstall Deep Security from your NSX environment" on page 1679](#). DS-47944
- Deep Security Manager no longer supports NSX-T Manager version 2.x. Upgrade your NSX-T Manager to version 3.0.0 or later. DS-50387

Compatibility

System requirements

Each part of a Deep Security deployment has its own system requirements.

- ["Deep Security Manager requirements" below](#)
- ["Deep Security Agent requirements" on page 332](#)
- ["Deep Security Relay requirements" on page 333](#)
- ["Deep Security Virtual Appliance requirements" on page 334](#)

Requirements vary by version. For older versions of Deep Security Manager, agents, relays, or virtual appliances, see their documentation.

Note: If you plan to operate Deep Security in FIPS mode, see ["FIPS 140 support" on page 1811](#) for additional requirements.

Deep Security Manager requirements

For a list of agent versions that are compatible with this version of the manager, see ["Agent platform compatibility" on page 336](#).

System component	Requirements
Minimum memory (RAM)	<p>Minimum RAM requirements depend on the number of agents that are being managed. See "Deep Security Manager sizing" on page 402.</p> <p>Note: On Linux, reserved system memory is separate from process memory. Therefore, although the installer's estimate might be similar, it will detect less RAM than the computer actually has. To verify the computer's actual total RAM, log in with a superuser account and enter:</p> <pre>grep MemTotal /proc/meminfo</pre>
Minimum	1.5 GB (200 GB recommended)

System component	Requirements
disk space	
Operating system	<ul style="list-style-type: none"> • Red Hat Enterprise Linux 9 (64-bit) • Red Hat Enterprise Linux 8 (64-bit) • Red Hat Enterprise Linux 7 (64-bit) • Windows Server 2019 (64-bit) • Windows Server 2016 (64-bit) • Windows Server 2012 or 2012 R2 (64-bit) • Windows Server 2022 (64-bit) <p>Note: Windows operating systems running in a Server Core configuration are not currently supported.</p> <p>Note: If you are upgrading your Deep Security Manager and are currently using Windows Server 2008, we recommend that you add a new Deep Security Manager node on a supported operating system (see "Install Deep Security Manager on multiple nodes" on page 488). When that's complete, decommission the node running on Windows Server 2008.</p>
Database	<ul style="list-style-type: none"> • PostgreSQL 14.x (only Core, Amazon RDS, or Amazon Aurora distributions) • PostgreSQL 13.x (only Core or Amazon RDS distributions) • PostgreSQL 12.x (only Core or Amazon RDS distributions) • PostgreSQL 11.x (only Core, Amazon RDS, or Amazon Aurora distributions) • Microsoft SQL Server 2022 • Microsoft SQL Server 2019 • Microsoft SQL Server 2017 • Microsoft SQL Server 2016 • Microsoft SQL Server 2014 • Microsoft SQL RDS

System component	Requirements
	<ul style="list-style-type: none"> • Azure SQL Database (SaaS) (multi-tenancy is not supported) • Oracle 19c is supported when deployed as software or when used with Amazon RDS • Oracle 23c is supported when deployed as software <p>Note:</p> <ul style="list-style-type: none"> • PostgreSQL minor versions for the preceding releases are also supported. • Microsoft SQL Server Express is only supported in very limited deployments. See "Microsoft SQL Server Express considerations" on page 436. • Microsoft SQL Server service packs for these versions are also supported. • Microsoft SQL Server is only supported when database containment is set to NONE. For details, see this Microsoft webpage on contained databases. • Oracle Database Express (XE) is not supported. • Oracle container database (CDB) configuration is not supported with Deep Security Manager multi-tenancy.
Web browser	<p>Cookies must be enabled.</p> <p>We recommend using the latest version of these browsers:</p> <ul style="list-style-type: none"> • Firefox • Microsoft Edge • Google Chrome • Apple Safari on a Mac

Deep Security Agent requirements

- Windows Agent

System component	Requirements
Processor	<ul style="list-style-type: none"> • Physical server: Intel Pentium Dual-Core or equivalent minimum, 4-Core or greater recommended • Virtual machine: 4 vCPU or greater recommended
RAM	2 GB minimum, 4 GB recommended
Disk	1 GB

Linux Agent

System component	Requirements
Processor	<ul style="list-style-type: none"> • Physical server: Intel Pentium Dual-Core or equivalent minimum, 4-Core or greater recommended • Virtual machine: 4 vCPU or greater recommended
RAM	2 GB minimum, 5 GB recommended
Disk	1 GB

Solaris Agent

System component	Requirements
Processor	Oracle SPARC processors
RAM	4 GB minimum, 4 GB recommended
Disk	2 GB

AIX Agent

System component	Requirements
Processor	IBM Power processors
RAM	4 GB minimum, 4 GB recommended
Disk	2 GB

Note: Installing the agent is only supported if the AIX Operating System is configured with the "en_US" locale.

Red Hat OpenShift Agent

System component	Requirements
Processor	<ul style="list-style-type: none"> Physical server: Intel Pentium Dual-Core or equivalent minimum, 4-Core or greater recommended Virtual machine: 4 vCPU or greater recommended
RAM	2GB remaining memory in the node
Disk	1.5GB

- Supported platforms (operating systems): See "[Agent platform compatibility](#)" on page 336.
- Supported features: [Supported Deep Security features vary by platform](#).

Note: The agent installer permits installation on any supported platform. RAM and disk space requirements are not checked.

Deep Security Relay requirements

Requirements are the same as those of the Deep Security Agent, with a few constraints:

- Relays are only supported on 64-bit operating systems.
- Relays are not supported on Solaris, AIX, or Red Hat OpenShift.
- Disk space requirements are higher for the Relay.

Platform	Minimum RAM	Recommended RAM	Minimum disk space for relay
Windows	2 GB	4 GB	30 GB
Linux	2 GB	4 GB	30 GB

If protected computers use VMware vMotion, add 10 GB of disk space to the Deep Security Relay that the agent is connected to.

Note:

Relays require more disk space if you install Deep Security Agent on many different platforms (Relays store update packages for each platform). For details, see ["Get Deep Security Agent software" on page 497](#).

In smaller deployments, relays can be co-located with a Deep Security Manager. If your deployment has a large number of agents (more than 10,000), however, then relays should be installed on separate, dedicated servers. Overloaded relays slow down update redistribution. See also ["Plan the best number and location of relays" on page 1416](#).

Deep Security Virtual Appliance requirements

Because the appliance uses the same protection modules as agents, if you import an update to the 64-bit agent for Red Hat, it may notify you that new software is available for the appliance, like it does for Red Hat agents.

Note: VMware does not support running nested ESXi servers in production environments. For more information, see the [VMware Knowledge Base article](#).

System component	Requirements
CPU	64-bit, Intel-VT or AMD-V present and enabled in UEFI. The number of CPUs varies by the number of VMs being protected. See "Deep Security Virtual Appliance sizing" on page 407 .
Minimum memory (RAM)	Varies by the number of VMs being protected. See "Deep Security Virtual Appliance sizing" on page 407 .

System component	Requirements
Minimum disk space	Varies by the number of VMs being protected. See " Deep Security Virtual Appliance sizing " on page 407.
VMware	<ul style="list-style-type: none"> • VMware component compatibility: Deep Security and VMware compatibility matrix. • vCloud: Deep Security and VMware Cloud (vCloud) Director Support Matrix. • For more information about VMware product interoperability, see VMware Interoperability Matrices.
vSwitches	<p>The chosen vSwitch of the appliance must be able to communicate with the manager at the management network level. It can be any one of the following types:</p> <ul style="list-style-type: none"> • vSphere Standard Switch (vSS) • vSphere Distributed Switch (vDS) • NSX-T Virtual Distributed Switch (N-VDS) <p>Note: An NSX-T 3.x network vSwitch configuration has specific requirements. For more information, please refer to the NSX-T Knowledge Base article.</p>
Guest VMs	<p>The VMs (guests) that will be protected by the virtual appliance have these requirements:</p> <ul style="list-style-type: none"> • Supported operating systems: See "Deep Security Virtual Appliance 20 (NSX) supported guest operating systems" on page 395. • Compatible vSphere versions: See this VMware Compatibility Guide. • Required drivers: If you plan to enable Anti-Malware protection through the virtual appliance, you must install the Guest Introspection Thin Agent with the File Introspection driver (<code>vsepflt</code>) on each guest. For installation instructions, see your VMware NSX-V documentation or NSX-T documentation and search for <code>Install the Guest Introspection</code>

System component	Requirements
	<p>Thin Agent.</p> <ul style="list-style-type: none"> To use Network Introspection (E-W) with NSX-T, the VMs (guests) must be linked to one of the following switches: <ul style="list-style-type: none"> NSX-T Virtual Distributed Switch (N-VDS) vSphere Distributed Switch (vDS) - new in vSphere 7.0: <ul style="list-style-type: none"> vDS 7.0 requires NSX-T 3.0, vCenter 7.0 and ESXi 7.0 or later
Deep Security Manager	Deep Security Manager 20.

Agent requirements

Agent platform compatibility

Agents can be installed on cloud, virtual, or physical computers, wherever the container or [operating system \(OS\)](#) and [kernel](#) are supported. Support is shown in the following table, with these indicators:

✓ – Supported. If support was added in an update, then the minimum required version is indicated in the footnote.

• – [Support for these releases is ending soon](#). Please upgrade as soon as possible.

The manager supports older agent versions, but you should still upgrade agents when possible. New agent releases provide more security features and protection, higher quality, performance improvements, and updates to stay in sync with OS releases. Regular software upgrades also ensure that, if an agent fix is required, you can simply update once – not install multiple updates along a supported upgrade path. Each agent has an end-of-life date. For details, see [Deep Security Agent LTS life cycle date](#) and [Deep Security Agent FR life cycle dates](#).

Note: Not all Deep Security features are available on all platforms. For details, see ["Supported features by platform" on page 360](#).

For details about which specific Windows 10 update releases are supported, see [Deep Security Support for Windows 10](#) and [Deep Security Support for Windows Server Core](#).

For details about which specific Windows 11 update releases are supported, see [Cloud One - Workload Security and Deep Security Support for Windows 11](#).

Operating System	Agent Version								
	20 LTS	12 FR	12 LTS	11.3	11.2	11.1	11 LTS	10 LTS	9.6
AIX 6.1 TL 9 or later 3, 12	✓		✓ 24						
AIX 7.1 TL 3 or later AIX 7.2 TL 0 or later 3	✓		✓ 24						
AIX 7.3 TL 0 or later 3	✓ 35								
AlmaLinux 8 (64-bit) 6	✓ 29								
AlmaLinux 9 (64-bit) 38	✓ 37								
Amazon Linux (64-bit)	✓	✓	✓	•	•	•	✓		
Amazon Linux 2 (64-bit)	✓	✓	✓	•	•	•	✓		
Amazon Linux 2 (AWS ARM-Based Graviton 2)	✓ 27								
Amazon Linux 2 (AWS ARM-Based Graviton 3)	✓ 34								
Amazon Linux 2023 (64-bit)	✓ 39								
Amazon Linux 2023 (AWS ARM-Based Graviton 2)	✓ 39								
CentOS 5 (32- and 64-bit)								✓	

Operating System	Agent Version								
	20 LTS	12 FR	12 LTS	11.3	11.2	11.1	11 LTS	10 LTS	9.6
CentOS 6 (32- and 64-bit)	✓	✓	✓	•	•	•	✓		
CentOS 7 (64-bit)	✓	✓	✓	•	•	•	✓		
CentOS 8 (64-bit)	✓	✓	✓ 23				✓ 32		
CloudLinux 5 (32- and 64-bit)									✓
CloudLinux 6 (32-bit)								✓	
CloudLinux 6 (64-bit)							✓ 16		
CloudLinux 7 (64-bit)	✓	✓	✓	•	•	•	✓		
CloudLinux 8 (64-bit)	✓	✓ 26							
Debian Linux 6 (64-bit)									✓
Debian Linux 7 (64-bit)			✓	•	•	•	✓		
Debian Linux 8 (64-bit) 12	✓	✓	✓	•	•	•	✓		
Debian Linux 9 (64-bit)	✓	✓	✓	•	•	•	✓		
Debian Linux 10 (64-bit)	✓	✓	✓ 21				✓ 20		
Debian Linux 11 (64-bit)	✓ 31								
Debian Linux 12 (64-bit)	✓ 43								
Miracle Linux 8 (64-bit)	✓ 40								

Operating System	Agent Version								
	20 LTS	12 FR	12 LTS	11.3	11.2	11.1	11 LTS	10 LTS	9.6
Miracle Linux 9 (64-bit)	✓ 42								
Oracle Linux 5 (32- and 64-bit)								✓	
Oracle Linux 6 (32- and 64-bit)	✓	✓	✓	•	•	•	✓		
Oracle Linux 7 (64-bit)	✓	✓	✓	•	•	•	✓		
Oracle Linux 8 (64-bit)	✓	✓	✓ 22				✓ 20		
Oracle Linux 9 (64-bit)	✓								
Red Hat Enterprise Linux 5 (32- and 64-bit)								✓	
Red Hat Enterprise Linux 6 (32- and 64-bit)	✓	✓	✓	•	•	•	✓		
Red Hat Enterprise Linux 7 (64-bit)	✓	✓	✓	•	•	•	✓		
Red Hat Enterprise Linux 8 (64-bit)	✓	✓	✓				✓ 18		
Red Hat Enterprise Linux 8 (AWS ARM-Based Graviton 2)	✓ 31								
Red Hat Enterprise Linux 8.6 (PowerPC little-endian)	✓ 41								
Red Hat Enterprise Linux 9 (64-bit)	✓ 34								
Red Hat Enterprise Linux Workstation 7 (64-bit)	✓ 37								
Red Hat OpenShift 4.9 - 4.13	✓								

Operating System	Agent Version								
	20 LTS	12 FR	12 LTS	11.3	11.2	11.1	11 LTS	10 LTS	9.6
	✓ 34								
Rocky Linux 8 (64-bit) 6	✓ 29								
Rocky Linux 9 (64-bit) 7	✓ 36								
Solaris 10 Updates 4-6 (64-bit or SPARC)	✓		✓				✓ 16		
Solaris 10 Updates 7-10 (64-bit or SPARC)	✓		✓				✓ 16		
Solaris 10 Update 11 (64-bit or SPARC)	✓		✓				✓ 16		
Solaris 11.0 (1111)-11.1 (64-bit or SPARC)	✓		✓				✓ 16		
Solaris 11.2-11.3 (64-bit or SPARC)	✓		✓				✓ 16		
Solaris 11.4 (64-bit or SPARC)	✓		✓				✓ 17		
SUSE Linux Enterprise Server 11 (32- and 64-bit)			✓	•	•	•	✓	✓	
SUSE Linux Enterprise Server 12 (64-bit)	✓	✓	✓	•	•	•	✓	✓	
SUSE Linux Enterprise Server 12 SP5 (PowerPC little-endian)	✓ 41								
SUSE Linux Enterprise Server 15 (64-bit)	✓	✓	✓				✓ 19		
SUSE Linux Enterprise Server 15 SP2, SP3, SP4 (PowerPC little-)	✓ 41								

Operating System	Agent Version								
	20 LTS	12 FR	12 LTS	11.3	11.2	11.1	11 LTS	10 LTS	9.6
endian)									
Ubuntu 10.04 (64-bit)									✓
Ubuntu 12.04 (64-bit)									✓
Ubuntu 14.04 (64-bit)								✓	
Ubuntu 16.04 (64-bit)	✓	✓	✓	•	•	•	✓		
Ubuntu 18.04 (64-bit)	✓	✓	✓	•	•		✓ 14		
Ubuntu 18.04 (AWS ARM-Based Graviton 2)	✓ 28								
Ubuntu 20.04 (64-bit)	✓	✓	✓ 25						
Ubuntu 20.04 (AWS ARM-Based Graviton 2)	✓ 29								
Ubuntu 22.04 (64-bit)	✓ 33								
Ubuntu 22.04 (AWS ARM-Based Graviton 2)	✓ 35								
Windows 2000, Service Pack 3 or 4 (32-bit) 4									✓ 13
Windows XP (32-bit and 64-bit) 4, 8								✓	
Windows Server 2003 SP1 or SP2 (32-bit and 64-bit) 4, 9								✓	
Windows Server 2003 R2 SP2 (32-bit and 64-bit) 4, 9								✓	

Operating System	Agent Version								
	20 LTS	12 FR	12 LTS	11.3	11.2	11.1	11 LTS	10 LTS	9.6
Windows 7 (32-bit and 64-bit) 12	✓	✓	✓	•	•	•	✓		
Windows 7 Embedded (32-bit) 1, 5, 12	✓	✓	✓	•					
Windows Server 2008 (32-bit and 64-bit) 2, 10, 12	✓	✓	✓	•	•	•	✓		
Windows Server 2008 R2 (64-bit) 2, 11	✓	✓	✓	•	•	•	✓		
Windows 8 (32-bit and 64-bit) 5, 12	✓	✓	✓	•	•	•	✓		
Windows 8.1 (32-bit and 64-bit) 12	✓	✓	✓	•	•	•	✓		
Windows 8.1 Embedded (32-bit) 1, 12	✓	✓	✓	•					
Windows 10 (32-bit and 64-bit)	✓	✓	✓	•	•	•	✓		
Windows 10 IoT Enterprise 2019 LTSC (32-bit and 64-bit) 1	✓	✓	✓						
Windows 10 IoT Enterprise 2021 LTSC (64-bit) 1	✓	✓	✓						
Windows 10 Enterprise multi-session (64-bit)	✓								
Windows 11 (64-bit)	✓								
Windows Server 2012 (64-bit)	✓	✓	✓	•	•	•	✓		
Windows Server 2012 R2 (64-bit)	✓	✓	✓	•	•	•	✓		
Windows Server 2016 (LTSC, version 1607) (64-bit)	✓	✓	✓	•	•	•	✓		

Operating System	Agent Version								
	20 LTS	12 FR	12 LTS	11.3	11.2	11.1	11 LTS	10 LTS	9.6
Windows Server Core (SAC, version 1709) (64-bit) 5	✓	✓	✓	•	•	•	✓		
Windows Server 2019 (LTSC, version 1809) (64-bit)	✓	✓	✓	•			✓ 15		
Windows Server 2022 (LTSC, version 21H2) (64-bit)	✓ 30								

Minor Linux version compatibility

Trend Micro releases agents for major Linux versions, such as Red Hat Enterprise Linux 9. Minor Linux versions such as Red Hat Enterprise Linux 9.x are also compatible if they use a kernel that the agent supports.

To determine if the computer has a supported kernel or not, see your OS provider's documentation and compare the computer's kernel version with "[Linux kernel compatibility](#)" on [page 349](#).

Docker compatibility

Agent 10.0 or later can protect Docker hosts and containers running on Linux distributions. Windows is not supported.

With each Deep Security long-term support (LTS) release, Deep Security supports all [Docker Enterprise Edition \(EE\) versions](#) that have not reached end-of-life. Trend Micro does not officially support Docker Edge releases.

Support for the latest stable Docker release is introduced with each release of Deep Security. Do not upgrade to the newest stable release of Docker until Trend Micro announces support for it in the newest release of Deep Security.

Note: Deep Security support for Docker releases includes any sub-versions of those releases. For example, Deep Security Agent 11.0 supports Docker 17.09-ce including its sub-versions: 17.09.0-ce and 17.09.1-ce.

Agent Version	Docker		Docker CE								Docker EE						
	v1.12	v1.13	17.03	17.09	17.12	18.03	18.06	18.09	18.09	19.03	20.10	17.06	18.03	18.06	18.09	19.03	20.10
10 LTS	✓	✓															
11 LTS			✓	✓	✓							✓	✓	✓	✓	✓	✓
11.1					✓	✓						✓	✓				
11.2						✓	✓					✓	✓				
11.3							✓	✓				✓	✓				
12 LTS							✓	✓				✓	✓	✓	✓	✓	✓
12 FR									✓			✓	✓	✓	✓	✓	✓
20 LTS									✓	✓		✓	✓	✓	✓	✓	✓

Footnotes:

1

Because embedded operating systems usually run on custom hardware (for example, on point-of-sale terminals), you should thoroughly test your specific hardware platform prior to deployment in a production environment. Trend Micro tests Windows Embedded platforms in a virtualized environment. If you need to raise a case with Trend Micro Support, try to reproduce the problem in a virtualized environment. If the issue cannot be reproduced in a virtualized

environment, and is specific to your custom hardware, Trend Micro Support might require you to provide remote access to it for diagnostics.

Note: Windows 10 IoT was formerly named Windows 10 Embedded, and is therefore considered a Windows Embedded platform.

2

Requires a Full/Desktop Experience installation. Server Core is not supported.

3

These AIX configurations are supported:

- **AIX LPARs on a PowerVM Hypervisor on a Power Server**
- **AIX as the bare metal OS on a Power Server**

4

In August 2019, Microsoft changed code signing requirements to stop using SHA-1 and use only SHA-2. Therefore these legacy OS must have the patch installed to enable verification of SHA-2 signatures on newer update releases of Deep Security Agent. See also:

- [Updated guidance for use of Trend Micro Deep Security to protect Windows 2003, Windows XP, and Windows 2000 based systems](#)
- [New versions of Trend Micro Deep Security Agents for Windows will only be signed with SHA-2 \(also available in Japanese\)](#)

5

In February 2023, Microsoft changed code signing requirements, but has not released a patch for this OS. Therefore the last supported update release for Deep Security Agent 20 is in January 2023.

6

AlmaLinux 8 and Rocky Linux 8 are supported by Deep Security Agent 20.0.0-3288+ for Red Hat Enterprise Linux 8.

7

Rocky Linux 9 is supported on Deep Security Agent 20.0.0-6313+ for Red Hat Enterprise Linux 9.

8

Windows XP support requires Deep Security Agent 10.0 Update 25 or earlier.

9

Windows Server 2003 support requires Deep Security Agent 10.0 Update 25 or earlier, or Update 29 and later. It is not supported with Updates 26, 27, and 28. See also [Deep Security Agent version 10 update 26 cannot be used for installation or upgrade on Windows XP/2003](#).

10

Windows Server 2008 support requires the SP2 service pack.

11

Windows Server 2008 R2 support requires the SP1 service pack.

12

In the second half of 2023, Deep Security Agent 20 for Windows Server 2008, AIX 6.1, and Debian Linux 8 will reach end of standard support. For more information, see [Limited Support for Windows Server 2008, AIX 6.1 and Debian Linux 8 after Deep Security Agent Version Revision in 2nd Half of 2023 Update Release](#).

13

Requires Deep Security Agent 9.6.2-8436 U17 (2018-05-03) or later.

14

Requires Deep Security Agent 11.0.0-390 U2 (2018-09-18) or later.

15

Requires Deep Security Agent 11.0.0-514 U4 (2018-12-04) or later.

16

Requires Deep Security Agent 11.0.0-582 U6 (2019-01-23) or later.

17

Requires Deep Security Agent 11.0.0-615 U7 (2019-02-22) or later.

18

Requires Deep Security Agent 11.0.0-796 U12 (2019-06-22) or later.

Trend Micro Deep Security On-Premise 20

19

Requires Deep Security Agent 11.0.0-871 U13 (2019-07-26) or later.

20

Requires Deep Security Agent 11.0.0-946 U14 (2019-08-29) or later.

21

Requires Deep Security Agent 12.0.0-481 U1 (2019-08-09) or later.

22

Requires Deep Security Agent 12.0.0-563 U2 (2019-09-13) or later.

23

Requires Deep Security Agent 12.0.0-682 U3 (2019-11-05) or later.

24

Requires Deep Security Agent 12.0.0-767 U5 (2019-12-16) or later.

25

Requires Deep Security Agent 12.0.0-1090 U10 (2020-05-28) or later.

26

Requires Deep Security Agent 12.5.0-936 FR (2020-05-19) or later.

27

Requires Deep Security Agent 20.0.0-1822 (20 LTS Update 2021-01-18) or later.

28

Requires Deep Security Agent 20.0.0-3165 (20 LTS Update 2021-10-08) or later.

29

Requires Deep Security Agent 20.0.0-3288 (20 LTS Update 2021-10-28) or later.

30

Requires Deep Security Agent 20.0.0-3445 (20 LTS Update 2021-11-24) or later.

31

Requires Deep Security Agent 20.0.0-3964 (20 LTS Update 2022-03-01) or later.

- 32**
Requires Deep Security Agent 11.0.0-328 U17 (2022-06-15) or later.
- 33**
Requires Deep Security Agent 20.0.0-4959 (20 LTS Update 2021-07-04) or later.
- 34**
Requires Deep Security Agent 20.0.0-5137 (20 LTS Update 2022-07-26) or later.
- 35**
Requires Deep Security Agent 20.0.0-5394 (20 LTS Update 2022-08-29) or later.
- 36**
Requires Deep Security Agent 20.0.0-6313 (20 LTS Update 2023-01-31) or later.
- 37**
Requires Deep Security Agent 20.0.0-6912 (20 LTS Update 2023-05-02) or later.
- 38**
AlmaLinux 9 is supported by Deep Security Agent 20.0.0-6912+ for Red Hat Enterprise Linux 9.
- 39**
Requires Deep Security Agent 20.0.0-7303 (20 LTS Update 2023-06-28) or later.
- 40**
Miracle Linux 8 is supported by Deep Security Agent 20.0.0-7719 (20 LTS Update 2023-08-29) or later for Red Hat Enterprise Linux 8.
- 41**
Requires Deep Security Agent 20.0.0-7943 (20 LTS Update 2023-09-26) or later.
- 42**
Miracle Linux 9 is supported by Deep Security Agent 20.0.0-8137 (20 LTS Update 2023-10-26) or later for Red Hat Enterprise Linux 9.
- 43**
Requires Deep Security Agent 20.0.0-8438 (20 LTS Update 2023-12-12) or later.

Linux kernel compatibility

Deep Security supports the following Linux kernel scopes:

- General kernel, which includes general-purpose Linux kernels available to all customers. These kernels are provided by supported operating system partners listed in [Deep Security Agent platform compatibility](#).
- Select extended support kernel, which includes the following:
 - Red Hat Enterprise Linux (RHEL). For information, see [Extended Update Support \(EUS\)](#).
 - SuSE Enterprise Server (SLES). For information, see [Long-Term Service Pack Support \(LTSS\)](#).

Supported Linux kernels vary by the agent version:

- [Deep Security Agent 20 Linux kernel support](#)
- [Deep Security Agent Feature Releases \(12.5\) Linux kernel support](#)
- [Deep Security Agent 12.0 Linux kernel support](#)
- [Deep Security Agent 11.3 Linux kernel support](#)
- [Deep Security Agent 11.2 Linux kernel support](#)
- [Deep Security Agent 11.1 Linux kernel support](#)
- [Deep Security Agent 11.0 Linux kernel support](#)
- [Deep Security Agent 10.3 Linux kernel support](#)
- [Deep Security Agent 10.2 Linux kernel support](#)
- [Deep Security Agent 10.1 Linux kernel support](#)
- [Deep Security Agent 10.0 Linux kernel support](#)
- [Deep Security Agent 9.6 SP1 Linux kernel support](#)
- [Deep Security Agent 9.5 SP1 Linux kernel support](#)

You can also use a [JSON list of Linux kernels that the agent supports](#) with scripts and automated workflows.

Disable optional Linux kernel support package updates

In previous agent versions, the kernel driver update process always downloaded the latest kernel support package from the relay when an agent was restarted or the computer rebooted. However, unless you have upgraded the kernel, the agent often does not need to update its kernel support package. Therefore for Deep Security Agent 20.0.0-3067+ with Deep Security Manager 20.0.503+, you can disable optional kernel support package updates to improve performance. For details, see ["Supported features by platform" on page 360](#).

Disable kernel support package updates on *one* computer

1. In Deep Security Manager, go to **Computers**.
2. Double-click the computer where you want to disable kernel support package updates (or select the computer and then select **Details**).
3. Select **Settings**. From **Automatically update kernel package when agent restarts**, select **No**.
4. Save your changes.

Disable kernel support package updates on *multiple* computers

1. In Deep Security Manager, go to **Policies**.
2. Double-click the policy that protects multiple computers where you want to disable kernel support package updates (or select the policy and then **Details**).
3. Select **Settings**. From **Automatically update kernel package when agent restarts**, select **No**.
4. Save your changes.

Linux file system compatibility

Real-time Anti-Malware scans require compatible file system hooks. On Linux platforms, various file systems can be used. Compatible file systems are shown in the following table.

Note: To protect network file systems, you must select **Enable network directory scan** in the malware scan configuration. For information, see ["Scan a network directory \(real-time scan only\)" on page 820](#).

File System Type		Agent Version											
		20	12 FR	12.0	11.3	11.2	11.1	11.0	10.3	10.2	10.1	10.0	9.6
Disk file systems	ext2	✓	✓	✓	✓	✓	✓	✓	✓	✓	✓	✓	✓
	ext3	✓	✓	✓	✓	✓	✓	✓	✓	✓	✓	✓	✓
	ext4	✓	✓	✓	✓	✓	✓	✓	✓	✓	✓	✓	✓
	XFS	✓	✓	✓	✓	✓	✓	✓	✓	✓	✓	✓	✓
	Btrfs	✓	✓	✓	✓	✓	✓	✓	✓	✓	✓	✓	✓
	VFAT	✓	✓	✓	✓	✓	✓	✓	✓	✓	✓	✓	✓
Optical discs	ISO 9660	✓	✓	✓	✓	✓	✓	✓	✓	✓	✓	✓	✓
Special file systems	tmpfs	✓	✓	✓	✓	✓	✓	✓	✓	✓	✓	✓	✓
	aufs	✓	✓	✓	✓	✓	✓	✓	✓	✓	✓	✓	
	OverlayFS	✓	✓	✓	✓	✓	✓	✓	✓	✓	✓	✓	✓
Network file systems (see Note, below)	NFSv3	✓	✓	✓	✓	✓	✓	✓	✓	✓	✓	✓	✓
	NFSv4	✓	✓	✓	✓	✓	✓	✓	✓	✓	✓	✓	✓
	SMB	✓	✓	✓	✓	✓	✓	✓	✓	✓	✓	✓	✓
	CIFS	✓	✓	✓	✓	✓	✓	✓	✓	✓	✓	✓	✓
	FTP	✓	✓	✓	✓	✓	✓	✓	✓	✓	✓	✓	✓

Linux systemd support

Some agent versions support [systemd](#) for Linux.

✓ – Supported. If support was added in an update, then the minimum required version is indicated in the footnote.

• – [Support for these releases is ending soon](#). Please upgrade as soon as possible.

Operating System	Agent Version			
	20 LTS	12 FR	12 LTS	11 LTS
AlmaLinux 8 (64-bit)	✓ 9			
AlmaLinux 9 (64-bit)	✓ 16			
Amazon Linux 2 (64-bit)				
Amazon Linux 2 (AWS ARM-Based Graviton 2)	✓ 7			
Amazon Linux 2 (AWS ARM-Based Graviton 3)	✓ 12			
Amazon Linux 2023 (64-bit)	✓ 17			
Amazon Linux 2023 (AWS ARM-Based Graviton 2)	✓ 17			
CloudLinux 8 (64-bit)	✓	✓ 5		
Debian Linux 10 (64-bit)	✓	✓	✓ 3	✓ 4
Debian Linux 11 (64-bit)	✓ 10			
Debian Linux 12 (64-bit)	✓ 21			
Miracle Linux 8 (64-bit)	✓ 18			
Miracle Linux 9 (64-bit)	✓ 20			
Oracle Linux 7 (64-bit)	✓	✓	✓ 3	✓ 2
Oracle Linux 8 (64-bit)	✓	✓	✓ 6	✓ 4

Operating System	Agent Version			
	20 LTS	12 FR	12 LTS	11 LTS
Oracle Linux 9 (64-bit)	✓ 15			
Red Hat Enterprise Linux 7 (64-bit)	✓	✓	✓ 3	✓ 2
Red Hat Enterprise Linux 8 (64-bit)	✓	✓	✓	✓ 1
Red Hat Enterprise Linux 8 (AWS ARM-Based Graviton 2)	✓ 10			
Red Hat Enterprise Linux 8.6 (PowerPC little-endian)	✓ 19			
Red Hat Enterprise Linux 9 (64-bit)	✓ 12			
Rocky Linux 8 (64-bit)	✓ 9			
Rocky Linux 9 (64-bit)	✓ 14			
SUSE Linux Enterprise Server 12 SP5 (PowerPC little-endian)	✓ 19			
SUSE Linux Enterprise Server 15 (64-bit)	✓	✓	✓	✓ 2
SUSE Linux Enterprise Server 15 SP2, SP3, SP4 (PowerPC little-endian)	✓ 19			
Ubuntu 18.04 (64-bit)	✓	✓		
Ubuntu 18.04 (AWS ARM-Based Graviton 2)	✓ 9			
Ubuntu 20.04 (64-bit)	✓			
Ubuntu 20.04 (AWS ARM-Based Graviton 2)	✓ 9			
Ubuntu 22.04 (64-bit)	✓ 11			

Operating System	Agent Version			
	20 LTS	12 FR	12 LTS	11 LTS
Ubuntu 22.04 (AWS ARM-Based Graviton 2)	✓ 13			

Footnotes:

1

Requires Deep Security Agent 11.0.0-796 U12 (2019-06-22) or later.

2

Requires Deep Security Agent 11.0.0-871 U13 (2019-07-26) or later.

3

Requires Deep Security Agent 12.0.0-481 U1 (2019-08-09) or later.

4

Requires Deep Security Agent 11.0.0-946 U14 (2019-08-29) or later.

5

Requires Deep Security Agent 12.5.0-936 FR (2020-05-19) or later.

6

Requires Deep Security Agent 12.0.0-563 U2 (2019-09-13) or later.

7

Requires Deep Security Agent 20.0.0-1822 (20 LTS Update 2021-01-18) or later.

8

Requires Deep Security Agent 20.0.0-3165 (20 LTS Update 2021-10-08) or later.

9

Requires Deep Security Agent 20.0.0-3288 (20 LTS Update 2021-10-28) or later.

10

Requires Deep Security Agent 20.0.0-3964 (20 LTS Update 2022-03-01) or later.

Trend Micro Deep Security On-Premise 20

- 11**
Requires Deep Security Agent 20.0.0-4959 (20 LTS Update 2021-07-04) or later.
- 12**
Requires Deep Security Agent 20.0.0-5137 (20 LTS Update 2022-07-26) or later.
- 13**
Requires Deep Security Agent 20.0.0-5394 (20 LTS Update 2022-08-29) or later.
- 14**
Requires Deep Security Agent 20.0.0-6313 (20 LTS Update 2023-01-31) or later.
- 15**
Requires Deep Security Agent 20.0.0-6658 (20 LTS Update 2023-03-22) or later.
- 16**
Requires Deep Security Agent 20.0.0-6912 (20 LTS Update 2023-05-02) or later.
- 17**
Requires Deep Security Agent 20.0.0-7303 (20 LTS Update 2023-06-28) or later.
- 18**
Miracle Linux 8 is supported by Deep Security Agent 20.0.0-7719 (20 LTS Update 2023-08-29) or later for Red Hat Enterprise Linux 8.
- 19**
Requires Deep Security Agent 20.0.0-7943 (20 LTS Update 2023-09-26) or later.
- 20**
Miracle Linux 9 is supported by Deep Security Agent 20.0.0-8137 (20 LTS Update 2023-10-26) or later for Red Hat Enterprise Linux 9.
- 21**
Requires Deep Security Agent 20.0.0-8438 (20 LTS Update 2023-12-12) or later.

Linux Secure Boot support

Some versions of the agent for Linux support [Secure Boot](#). See also [Configure Linux Secure Boot for agents](#).

Each operating system is associated with corresponding Secure Boot public keys, such as `DS20.der`, `DS20_V2.der`, and so on. These keys have different expiration dates. For more information, see "Update the Trend Micro public key - The public key has expired" section in [Configure Linux Secure Boot for agents](#).

Note that Deep Security Agent does not currently support Secure Boot on Azure VMs.

✓ – Supported. If support was added in an update, then the minimum required version is indicated in the footnote.

• – [Support for these releases is ending soon](#). Please upgrade as soon as possible.

Operating System	Agent Version			
	20 LTS	12 FR	12 LTS	11 LTS
AlmaLinux 9 (64-bit)	✓ 5			
CentOS 7 (64-bit)	✓	✓	✓	✓
CentOS 8 (64-bit)	✓	✓		
Debian Linux 10 (64-bit)	✓	✓		
Debian Linux 11 (64-bit)	✓			
Debian Linux 12 (64-bit)	✓ 7			
Miracle Linux 9 (64-bit)	✓ 6			
Oracle Linux 7 (64-bit)	✓ 1			
Oracle Linux 8 (64-bit)	✓ 2			
Oracle Linux 9 (64-bit)	✓			
Red Hat Enterprise Linux 7 (64-bit)	✓	✓	✓	✓

Operating System	Agent Version			
	20 LTS	12 FR	12 LTS	11 LTS
Red Hat Enterprise Linux 8 (64-bit)	✓	✓		
Red Hat Enterprise Linux 9 (64-bit)	✓			
Red Hat Enterprise Linux Workstation 7 (64-bit)	✓ 5			
Rocky Linux 9 (64-bit)	✓ 3			
SUSE Linux Enterprise Server 12 (64-bit)	✓	✓		
SUSE Linux Enterprise Server 15 (64-bit)	✓	✓		
Ubuntu 16.04 (64-bit)	✓	✓		
Ubuntu 18.04 (64-bit)	✓	✓		
Ubuntu 20.04 (64-bit)	✓			
Ubuntu 22.04 (64-bit)	✓ 4			

Footnotes:**1**

Requires Deep Security Agent 20.0.0-3165 (20 LTS Update 2021-10-08) or later.

2

Requires Deep Security Agent 20.0.0-3288 (20 LTS Update 2021-10-28) or later.

3

Requires Deep Security Agent 20.0.0-6313 (20 LTS Update 2023-01-31) or later.

4

Requires Deep Security Agent 20.0.0-6658 (20 LTS Update 2023-03-22) or later.

5

Requires Deep Security Agent 20.0.0-6912 (20 LTS Update 2023-05-02) or later.

6

Miracle Linux 9 is supported by Deep Security Agent 20.0.0-8137 (20 LTS Update 2023-10-26) or later for Red Hat Enterprise Linux 9.

7

Requires Deep Security Agent 20.0.0-8438 (20 LTS Update 2023-12-12) or later.

SELinux support

[Security-Enhanced Linux](#) (SELinux) enforcing mode is supported on the following OS and agent combinations, using the default SELinux policies.

✓ – Supported. If support was added in an update, then the minimum required version is indicated in the footnote.

• – [Support for these releases is ending soon](#). Please upgrade as soon as possible.

Warning: Anti-malware software such as the agent **>must>** run in an unconfined domain in order to protect the whole computer. Any additional SELinux policy customization or configuration could block the agent. If any alerts occur, see [Troubleshoot SELinux alerts](#).

Operating System	Agent Version		
	20 LTS	12 FR	12 LTS
AlmaLinux 8 (64-bit)	✓		
Amazon Linux (64-bit)	✓		
Amazon Linux 2 (64-bit)	✓		
Amazon Linux 2 (AWS ARM-Based Graviton 2)	✓		
Amazon Linux 2 (AWS ARM-Based Graviton 3)	✓		
Amazon Linux 2023 (64-bit)	✓		
Amazon Linux 2023 (AWS ARM-Based Graviton 2)	✓		
CentOS 6 (64-bit)	✓		

Operating System	Agent Version		
	20 LTS	12 FR	12 LTS
CentOS 7 (64-bit)	✓		
CentOS 8 (64-bit)	✓		
Oracle Linux 6 (32-bit)	✓		
Oracle Linux 6 (64-bit)	✓		
Oracle Linux 7 (64-bit)	✓		
Oracle Linux 8 (64-bit)	✓		
Oracle Linux 9 (64-bit)	✓		
Red Hat Enterprise Linux 7 (64-bit)	✓	✓ 1	✓ 2
Red Hat Enterprise Linux 8 (64-bit)	✓	✓ 1	✓ 2
Rocky Linux 8 (64-bit)	✓		
Rocky Linux 9 (64-bit)	✓		

Footnotes:**1**

Requires Deep Security Agent 12.5.0-936 FR (2020-05-19) or later.

2

Requires Deep Security Agent 12.0.0-1026 U9 (2020-05-04) or later.

Supported features by platform

The following tables list the security features available for each OS platform of **Deep Security Agent 20** and the **Deep Security Virtual Appliance**:

Note:

Older agents are compatible with other platforms, although they do not support new features. See ["Agent platform compatibility" on page 336](#) for a complete list of compatible agents. To see the features available with older agents:

AIX

For a list of supported AIX versions, see ["Agent platform compatibility" on page 336](#).

Anti-Malware						Web Reputation Service	Firewall	Intrusion Prevention System			Integrity Monitoring					Log Inspection	Application Control	Recommendation Scan	Relay	Scanner	Visio n One (XDR)	FIPS mode
Real-time					On-demand						Real-time			On-demand								
Feature Set 11	Process memory scan, Registry scan	Behavior monitoring	Predictive Machine Learning	Feature Set 11			Unencrypted Traffic	SSL Encrypted Traffic	Advanced TLS Traffic Inspection	FileScans	Directory Scans	Scans of Running Processes, Listening Ports	File and Directory Scans	Registry Scans	Scans of Running Processes, Listening Ports							
AIX 6.1				✓7			✓	✓	✓			✓	✓		✓	✓						

Trend Micro Deep Security On-Premise 20

	Anti-Malware					Web Reputation Service	Firewall	Intrusion Prevention System			Integrity Monitoring					Log Inspection	Application Control	Recommendation Scan	Relay	Scanner	Visio n One (XDR)	FIPS mode
	Real-time				On-demand						Real-time			On-demand								
	Feature Set 11	Process memory scan, Registry scan	Behavior monitoring	Predictive Machine Learning	Feature Set 11		Unencrypted Traffic	SSL Encrypted Traffic	Advanced TLS Traffic Inspection	FileScans	Directory Scans	Scans of Running Processes, Listening Ports	File and Directory Scans	Registry Scans	Scans of Running Processes, Listening Ports							
TL 9 or later																						
AIX 7.1 TL 3 or later					✓ 6		✓	✓	✓			✓	✓		✓	✓		✓				
AIX 7.2 TL 0 or later					✓ 6		✓	✓	✓			✓	✓		✓	✓		✓				

Trend Micro Deep Security On-Premise 20

Anti-Malware					Web Reputation Service	Firewall	Intrusion Prevention System			Integrity Monitoring					Log Inspection	Application Control	Recommendation Scan	Relay	Scanner	Visio n One (XDR)	FIPS mode	
Real-time				On-demand						Real-time		On-demand										
Feature Set 11	Process memory scan, Registry scan	Behavior monitoring	Predictive Machine Learning	Feature Set 11		Unencrypted Traffic	SSL Encrypted Traffic	Advanced TLS Traffic Inspection	FileScans	Directory Scans	Scans of Running Processes, Listening Ports	File and Directory Scans	Registry Scans	Scans of Running Processes, Listening Ports								
AIX 7.3 TL 0 or later				✓ 13		✓	✓	✓			✓	✓		✓	✓							

AlmaLinux

	Anti-Malware					Web Reputation Service	Firewall	Intrusion Prevention System			Integrity Monitoring					Log Inspection	Application Control	Recommendation Scan	Relay	Scanner	Visio n One (XDR)	FIPS mode
	Real-time				On-demand						Real-time			On-demand								
	Feature Set 11	Process memory scan, Registry scan	Behavior monitoring	Predictive Machine Learning	Feature Set 11		Unencrypted Traffic	SSL Encrypted Traffic	Advanced TLS Traffic Inspection 11	File Scans 5	Directory Scans	Scans of Running Processes, Listening Ports	File and Directory Scans	Registry Scans	Scans of Running Processes, Listening Ports							
AlmaLinux 8 (64-bit) 10	✓		✓	✓	✓	✓	✓	✓	✓	✓	✓	✓	✓		✓	✓	✓	✓			✓	
AlmaLinux 8 (64-bit) 10	✓		✓	✓	✓	✓	✓	✓	✓	✓	✓	✓	✓		✓	✓	✓	✓			✓	
AlmaLinux 9 (64-bit) 18	✓		✓	✓	✓	✓	✓	✓	✓	✓	✓	✓	✓		✓	✓	✓	✓			✓	

Amazon Linux

Real-time Anti-Malware requires a compatible file system. See ["Linux file system compatibility"](#) on page 350.

	Anti-Malware					Web Reputation Service	Firewall	Intrusion Prevention System	Integrity Monitoring						Log Inspection	Application Control	Recommendation Scan	Relay	Scanner	Vision One (XDR)	FIPS mode	
	Real-time				On-demand				Real-time			On-demand										
	Feature Set 11	Process memory scan, Registry scan	Behavior monitoring	Predictive Machine Learning 8	Feature Set 11			Unencrypted Traffic	SSL Encrypted Traffic	Advanced TLS Traffic Inspection	File Scans	Directory Scans	Scans of Running Processes, Listening Ports	File and Directory Scans	Registry Scans	Scans of Running Processes, Listening Ports						
Amazon Linux (64-bit)	✓		✓ 6	✓	✓	✓	✓	✓	✓		✓ 5		✓	✓		✓	✓	✓	✓	✓	✓	
Amazon Linux 2 (64-bit)	✓		✓ 6	✓	✓	✓	✓	✓	✓	✓ 11	✓ 5		✓	✓		✓	✓	✓	✓	✓	✓	✓ 9
Amazon Linux 2 (AWS)	✓ 7		✓ 7	✓	✓ 7	✓ 6	✓ 6	✓ 6	✓ 6		✓ 8		✓ 8	✓ 8		✓ 8	✓ 7	✓ 8	✓ 7	✓ 8	✓ 8	✓ 8

Trend Micro Deep Security On-Premise 20

	Anti-Malware					Web Reputation Service	Firewall	Intrusion Prevention System	Integrity Monitoring							Log Inspection	Application Control	Recommendation Scan	Relay	Scanner	Visio n One (XDR)	FIPS mode
	Real-time				On-demand				Real-time				On-demand									
	Feature Set 11	Process memory scan, Registry scan	Behavior monitoring	Predictive Machine Learning 8	Feature Set 11			Unencrypted Traffic	SSL Encrypted Traffic	Advanced TLS Traffic Inspection	File Scans	Directory Scans	Scans of Running Processes, Listening Ports	File and Directory Scans	Registry Scans	Scans of Running Processes, Listening Ports						
ARM-Based Graviton 2) 6 and Amazon Linux 2 (AWS ARM-Based Graviton 3) 12																						
Amazon Linux 2023 (64-bit) 20	✓		✓	✓	✓	✓	✓	✓	✓	✓	✓ 5		✓	✓		✓	✓	✓	✓	✓	✓	✓

Trend Micro Deep Security On-Premise 20

	Anti-Malware					Web Reputation Service	Firewall	Intrusion Prevention System	Integrity Monitoring							Log Inspection	Application Control	Recommendation Scan	Relay	Scanner	Visio n One (XDR)	FIPS mode
	Real-time				On-demand				Real-time				On-demand									
	Feature Set 11	Process memory scan, Registry scan	Behavior monitoring	Predictive Machine Learning 8	Feature Set 11			Unencrypted Traffic	SSL Encrypted Traffic	Advanced TLS Traffic Inspection	File Scans	Directory Scans	Scans of Running Processes, Listening Ports	File and Directory Scans	Registry Scans	Scans of Running Processes, Listening Ports						
Amazon Linux 2023 (AWS ARM-Based Graviton 2) 20	✓		✓	✓	✓	✓	✓	✓	✓		✓		✓	✓		✓	✓	✓	✓	✓	✓	✓

CentOS Linux

Real-time Anti-Malware requires a compatible file system. See ["Linux file system compatibility"](#) on page 350.

Trend Micro Deep Security On-Premise 20

	Anti-Malware					Web Reputation Service	Firewall	Intrusion Prevention System	Integrity Monitoring							Log Inspection	Application Control	Recommendation Scan	Relay	Scanner	Visio n One (XDR)	FIPS mode
	Real-time				On-demand				Real-time			On-demand										
	Feature Set 11	Process memory scan, Registry scan	Behavior monitoring 6	Predictive Machine Learning 8	Feature Set 11			Unencrypted Traffic	SSL Encrypted Traffic	Advanced TLS Traffic Inspection	File Scans	Directory Scans	Scans of Running Processes, Listening Ports	File and Directory Scans	Registry Scans	Scans of Running Processes, Listening Ports						
CentOS 6 (32-bit)	✓		✓	✓	✓		✓	✓	✓				✓	✓		✓	✓				✓	
CentOS 6 (64-bit)	✓		✓	✓	✓	✓	✓	✓	✓		✓ 5		✓	✓		✓	✓	✓	✓	✓	✓	
CentOS 7 (64-bit)	✓		✓	✓	✓	✓	✓	✓	✓	✓ 11	✓ 5		✓	✓		✓	✓	✓	✓	✓	✓	✓
CentOS 8 (64-bit)	✓		✓	✓	✓	✓	✓	✓	✓	✓ 11	✓ 5		✓	✓		✓	✓	✓	✓	✓	✓	

CloudLinux

Real-time Anti-Malware requires a compatible file system. See ["Linux file system compatibility"](#) on page 350.

	Anti-Malware					Web Reputation Service	Firewall	Intrusion Prevention System	Integrity Monitoring							Log Inspection	Application Control	Recommendation Scan	Relay	Scanner	Visio n One (XDR)	FIPS mode
	Real-time				On-demand				Real-time				On-demand									
	Feature Set 11	Process memory scan, Registry scan	Behavior monitoring 6	Predictive Machine Learning 8	Feature Set 11			Unencrypted Traffic	SSL Encrypted Traffic	Advanced TLS Traffic Inspection 11	File Scans 5	Directory Scans	Scans of Running Processes, Listening Ports	File and Directory Scans	Registry Scans	Scans of Running Processes, Listening Ports						
CloudLinux 7 (64-bit)	✓		✓	✓	✓	✓	✓	✓	✓	✓	✓		✓	✓		✓	✓	✓	✓	✓	✓	✓
CloudLinux 8 (64-bit)	✓		✓	✓	✓	✓	✓	✓	✓	✓	✓		✓	✓		✓	✓	✓	✓	✓	✓	✓

Debian Linux

Real-time Anti-Malware requires a compatible file system. See ["Linux file system compatibility"](#) on page 350.

Trend Micro Deep Security On-Premise 20

	Anti-Malware					Web Reputation Service	Firewall	Intrusion Prevention System	Integrity Monitoring							Log Inspection	Application Control	Recommendation Scan	Relay	Scanner	Visio n One (XDR)	FIPS mode
	Real-time				On-demand				Real-time			On-demand										
	Feature Set 11	Process memory scan, Registry scan	Behavior monitoring 6	Predictive Machine Learning 8	Feature Set 11			Unencrypted Traffic	SSL Encrypted Traffic	Advanced TLS Traffic Inspection	File Scans 5	Directory Scans	Scans of Running Processes, Listening Ports	File and Directory Scans	Registry Scans	Scans of Running Processes, Listening Ports						
Debian Linux 8 (64-bit)	✓		✓	✓	✓	✓	✓	✓	✓		✓		✓	✓		✓	✓	✓	✓	✓	✓	✓
Debian Linux 9 (64-bit)	✓		✓	✓	✓	✓	✓	✓	✓	✓ 11	✓		✓	✓		✓	✓	✓	✓	✓	✓	✓
Debian Linux 10	✓		✓	✓	✓	✓	✓	✓	✓	✓ 11	✓		✓	✓		✓	✓	✓	✓	✓	✓	✓

Trend Micro Deep Security On-Premise 20

Anti-Malware					Web Reputation Service	Firewall	Intrusion Prevention System	Integrity Monitoring						Log Inspection	Application Control	Recommendation Scan	Relay	Scanner	Visio n One (XDR)	FIPS mode	
Real-time				On-demand			Real-time			On-demand											
Feature Set 11	Process memory scan, Registry scan	Behavior monitoring 6	Predictive Machine Learning 8	Feature Set 11		Unencrypted Traffic	SSL Encrypted Traffic	Advanced TLS Traffic Inspection	File Scans 5	Directory Scans	Scans of Running Processes, Listening Ports	File and Directory Scans	Registry Scans	Scans of Running Processes, Listening Ports							
(64-bit)																					
Debian Linux 11 (64-bit)	✓	✓	✓	✓	✓	✓	✓	✓	✓	✓	✓	✓	✓	✓	✓	✓	✓	✓	✓	✓	✓
Debian Linux 12 (64-bit) 24	✓	✓	✓	✓	✓	✓	✓	✓	✓	✓	✓	✓	✓	✓	✓	✓	✓	✓	✓	✓	✓

Miracle Linux

Real-time Anti-Malware requires a compatible file system. See "[Linux file system compatibility](#)" on page 350.

	Anti-Malware					Web Reputation Service	Firewall	Intrusion Prevention System	Integrity Monitoring							Log Inspection	Application Control	Recommendation Scan	Relay	Scanner	Vision One (XDR)	FIPS mode
	Real-time				On-demand				Real-time			On-demand										
	Feature Set 11	Process memory scan, Registry scan	Behavior monitoring 6	Predictive Machine Learning 8	Feature Set 11			Unencrypted Traffic	SSL Encrypted Traffic	Advanced TLS Traffic Inspection 11	File Scans 5	Directory Scans	Scans of Running Processes, Listening Ports	File and Directory Scans	Registry Scans	Scans of Running Processes, Listening Ports						
Miracle Linux 8 (64-bit) 23	✓		✓	✓	✓	✓	✓	✓	✓	✓	✓			✓	✓	✓	✓	✓	✓	✓	✓	✓
Miracle Linux 9 (64-bit) 25	✓		✓	✓	✓	✓	✓	✓	✓	✓	✓			✓	✓	✓	✓	✓	✓	✓	✓	✓

Oracle Linux

Real-time Anti-Malware requires a compatible file system. See "[Linux file system compatibility](#)" on page 350.

	Anti-Malware					Web Reputation Service	Firewall	Intrusion Prevention System			Integrity Monitoring						Log Inspection	Application Control	Recommendation Scan	Relay	Scanner	Vision One (XDR)	FIPS mode
	Real-time				On-demand			Real-time			On-demand												
	Feature Set 11	Process memory scan, Registry scan	Behavior monitoring	Predictive Machine Learning	Feature Set 11		Unencrypted Traffic	SSL Encrypted Traffic	Advanced TLS Traffic Inspection	File Scans	Directory Scans	Scans of Running Processes, Listening Ports	File and Directory Scans	Registry Scans	Scans of Running Processes, Listening Ports								
Oracle Linux 6 (32-bit)					✓		✓	✓	✓			✓	✓		✓			✓					
Oracle Linux 6 (64-bit)	✓		✓ 6	✓ 8	✓	✓	✓	✓		✓ 5		✓	✓		✓	✓	✓	✓	✓			✓	

Trend Micro Deep Security On-Premise 20

	Anti-Malware					Web Reputation Service	Firewall	Intrusion Prevention System	Integrity Monitoring							Log Inspection	Application Control	Recommendation Scan	Relay	Scanner	Visio n One (XDR)	FIPS mode	
	Real-time				On-demand				Real-time			On-demand											
	Feature Set 11	Process memory scan, Registry scan	Behavior monitoring	Predictive Machine Learning	Feature Set 11			Unencrypted Traffic	SSL Encrypted Traffic	Advanced TLS Traffic Inspection	File Scans	Directory Scans	Scans of Running Processes, Listening Ports	File and Directory Scans	Registry Scans	Scans of Running Processes, Listening Ports							
Oracle Linux 7 (64-bit)	✓		✓ 6	✓ 8	✓	✓	✓	✓	✓	✓ 11	✓ 5		✓	✓		✓	✓	✓	✓	✓	✓ 14	✓	
Oracle Linux 8 (64-bit)	✓		✓ 6	✓ 8	✓	✓	✓	✓	✓	✓ 11	✓ 5		✓	✓		✓	✓	✓	✓	✓		✓	✓ 15
Oracle Linux 9 (64-bit)	✓		✓	✓	✓	✓	✓	✓	✓	✓ 20	✓ 5		✓	✓		✓	✓	✓	✓	✓		✓	

Note: Inspecting TLS traffic when Oracle Linux 8 is in FIPS mode requires using [Advanced TLS traffic inspection](#) to support the ciphers applied by its [predefined cryptographic policy](#).

Red Hat Enterprise Linux

Real-time Anti-Malware requires a compatible file system. See "[Linux file system compatibility](#)" on page 350.

	Anti-Malware					Web Reputation Service	Firewall	Intrusion Prevention System	Integrity Monitoring						Log Inspection	Application Control	Recommendation Scan	Relay	Scanner	Vision One (XDR)	FIPS mode
	Real-time				On-demand				Real-time			On-demand									
	Feature Set 11	Process memory scan, Registry scan	Behavior monitoring 6	Predictive Machine Learning 8	Feature Set 11		Unencrypted Traffic	SSL Encrypted Traffic	Advanced TLS Traffic Inspection	File Scans	Directory Scans	Scans of Running Processes, Listening Ports	File and Directory Scans	Registry Scans	Scans of Running Processes, Listening Ports						
Red Hat Enterprise Linux 6 (32-bit)	✓		✓	✓	✓		✓	✓	✓			✓	✓		✓					✓	
Red Hat Enterprise Linux 6 (64-bit)	✓		✓	✓	✓	✓	✓	✓	✓	✓ 5		✓	✓		✓	✓	✓	✓	✓	✓	✓

Trend Micro Deep Security On-Premise 20

	Anti-Malware					Web Reputation Service	Firewall	Intrusion Prevention System	Integrity Monitoring							Log Inspection	Application Control	Recommendation Scan	Relay	Scanner	Vision One (XDR)	FIPS mode
	Real-time				On-demand				Real-time			On-demand										
	Feature Set 11	Process memory scan, Registry scan	Behavior monitoring 6	Predictive Machine Learning 8	Feature Set 11			Unencrypted Traffic	SSL Encrypted Traffic	Advanced TLS Traffic Inspection 11	File Scans 5	Directory Scans	Scans of Running Processes, Listening Ports	File and Directory Scans	Registry Scans	Scans of Running Processes, Listening Ports						
Red Hat Enterprise Linux 7 (64-bit)	✓		✓	✓	✓	✓	✓	✓	✓	✓ 11	✓ 5		✓	✓		✓	✓	✓	✓	✓	✓	✓
Red Hat Enterprise Linux 8 (64-bit)	✓		✓	✓	✓	✓	✓	✓	✓	✓ 11	✓ 5		✓	✓		✓	✓	✓	✓	✓	✓	✓ 9
Red Hat Enterprise Linux 8 (AWS ARM-Based Graviton 2)	✓		✓	✓	✓	✓	✓	✓	✓		✓ 5		✓	✓		✓	✓	✓	✓		✓	

Trend Micro Deep Security On-Premise 20

	Anti-Malware					Web Reputation Service	Firewall	Intrusion Prevention System	Integrity Monitoring							Log Inspection	Application Control	Recommendation Scan	Relay	Scanner	Visio n One (XDR)	FIPS mode
	Real-time				On-demand				Real-time				On-demand									
	Feature Set 11	Process memory scan, Registry scan	Behavior monitoring 6	Predictive Machine Learning 8	Feature Set 11			Unencrypted Traffic	SSL Encrypted Traffic	Advanced TLS Traffic Inspection	File Scans	Directory Scans	Scans of Running Processes, Listening Ports	File and Directory Scans	Registry Scans	Scans of Running Processes, Listening Ports						
Red Hat Enterprise Linux 8.6 (PowerPC little-endian)					✓ 22																	
Red Hat Enterprise Linux 9 (64-bit)	✓		✓	✓	✓	✓	✓	✓	✓	✓ 20	✓ 5		✓	✓		✓	✓	✓	✓	✓	✓ 26	✓
Red Hat Enterprise Linux Workstation 7 (64-bit) 18	✓		✓	✓	✓	✓	✓	✓	✓	✓	✓ 5		✓	✓		✓	✓	✓	✓	✓		✓

Red Hat OpenShift

Real-time Anti-Malware requires a compatible file system. See ["Linux file system compatibility"](#) on page 350.

	Anti-Malware					Web Reputation Service	Firewall	Intrusion Prevention System	Integrity Monitoring							Log Inspection	Application Control	Recommendation Scan	Relay	Scanner	Visio n One (XDR)	FIPS mode
	Real-time				On-demand				Real-time				On-demand									
	Feature Set 11	Process memory scan, Registry scan	Behavior monitoring 6	Predictive Machine Learning 8	Feature Set 11			Unencrypted Traffic	SSL Encrypted Traffic	Advanced TLS Traffic Inspection	File Scans	Directory Scans	Scans of Running Processes, Listening Ports	File and Directory Scans	Registry Scans	Scans of Running Processes, Listening Ports						
OpenShift 4.9 - 4.13	✓		✓	✓																		

Rocky Linux

Real-time Anti-Malware requires a compatible file system. See ["Linux file system compatibility"](#) on page 350.

Trend Micro Deep Security On-Premise 20

Anti-Malware					Web Reputation Service	Firewall	Intrusion Prevention System	Integrity Monitoring							Log Inspection	Application Control	Recommendation Scan	Relay	Scanner	Visio n One (XDR)	FIPS mode
Real-time				On-demand			Real-time			On-demand											
Feature Set 11	Process memory scan, Registry scan	Behavior monitoring	Predictive Machine Learning	Feature Set 11		Unencrypted Traffic	SSL Encrypted Traffic	Advanced TLS Traffic Inspection 11	File Scans 5	Directory Scans	Scans of Running Processes, Listening Ports	File and Directory Scans	Registry Scans	Scans of Running Processes, Listening Ports							
Rocky Linux 8 (64-bit) 10	✓	✓	✓	✓	✓	✓	✓	✓	✓	✓	✓	✓	✓	✓	✓	✓	✓	✓	✓	✓	✓
Rocky Linux 9 (64-bit) 17	✓	✓	✓	✓	✓	✓	✓	✓	✓	✓	✓	✓	✓	✓	✓	✓	✓	✓	✓	✓	✓

Solaris

For a list of supported Solaris versions, see ["Agent platform compatibility" on page 336](#). For more information, see ["How does agent protection work for Solaris zones?" on page 1906](#)

Anti-Malware					Web Reputation Service	Firewall	Intrusion Prevention System			Integrity Monitoring					Log Inspection	Application Control	Recommendation Scan	Relay	Scanner	Visio n One (XDR)	FIPS mode
Real-time				On-demand ⁴						Real-time		On-demand									
Feature Set ^{1 1}	Process memory scan, Registry scan	Behavior monitoring	Predictive Machine Learning	Feature Set ^{1 1}		Unencrypted Traffic	SSL Encrypted Traffic	Advanced TLS Traffic Inspection	File Scans	Directory Scans	Scans of Running Processes, Listening Ports	File and Directory Scans	Registry Scans	Scans of Running Processes, Listening Ports							
Solaris				✓	✓	✓	✓	✓			✓	✓		✓	✓						

SUSE Linux

Real-time Anti-Malware requires a compatible file system. See ["Linux file system compatibility" on page 350](#).

Trend Micro Deep Security On-Premise 20

	Anti-Malware					Web Reputation Service	Firewall	Intrusion Prevention System	Integrity Monitoring							Log Inspection	Application Control	Recommendation Scan	Relay	Scanner	Visio n One (XDR)	FIPS mode	
	Real-time				On-demand				Real-time				On-demand										
	Feature Set 11	Process memory scan, Registry scan	Behavior monitoring 6	Predictive Machine Learning 8	Feature Set 11			Unencrypted Traffic	SSL Encrypted Traffic	Advanced TLS Traffic Inspection 11	File Scans 5	Directory Scans	Scans of Running Processes, Listening Ports	File and Directory Scans	Registry Scans	Scans of Running Processes, Listening Ports							
SUSE Linux Enterprise Server 12 SP1, SP2, SP3, SP4, SP5 (64-bit)	✓		✓	✓	✓	✓	✓	✓	✓	✓	✓		✓	✓		✓	✓	✓	✓	✓	✓	✓	14
SUSE Linux Enterprise Server 12 SP5 (PowerPC little-endian)	✓	✓	✓	✓	✓ 22	✓	✓	✓	✓	✓							✓		✓	✓			

Trend Micro Deep Security On-Premise 20

	Anti-Malware					Web Reputation Service	Firewall	Intrusion Prevention System			Integrity Monitoring					Log Inspection	Application Control	Recommendation Scan	Relay	Scanner	Visio n One (XDR)	FIPS mode
	Real-time				On-demand						Real-time			On-demand								
	Feature Set 11	Process memory scan, Registry scan	Behavior monitoring 6	Predictive Machine Learning 8	Feature Set 11			Unencrypted Traffic	SSL Encrypted Traffic	Advanced TLS Traffic Inspection 11	File Scans 5	Directory Scans	Scans of Running Processes, Listening Ports	File and Directory Scans	Registry Scans	Scans of Running Processes, Listening Ports						
SUSE Linux Enterprise Server 15 SP1, SP2, SP3, SP4 (64-bit)	✓		✓	✓	✓	✓	✓	✓	✓	✓	✓		✓	✓		✓	✓	✓	✓	✓	✓	✓ 14
SUSE Linux Enterprise Server 15 SP2, SP3, SP4 (PowerPC little-)	✓	✓	✓	✓	✓ 22	✓	✓	✓	✓	✓							✓		✓	✓		

Trend Micro Deep Security On-Premise 20

	Anti-Malware					Web Reputation Service	Firewall	Intrusion Prevention System	Integrity Monitoring							Log Inspection	Application Control	Recommendation Scan	Relay	Scanner	Visio n One (XDR)	FIPS mode
	Real-time				On-demand				Real-time				On-demand									
	Feature Set 11	Process memory scan, Registry scan	Behavior monitoring 6	Predictive Machine Learning 8	Feature Set 11			Unencrypted Traffic	SSL Encrypted Traffic	Advanced TLS Traffic Inspection 11	File Scans 5	Directory Scans	Scans of Running Processes, Listening Ports	File and Directory Scans	Registry Scans	Scans of Running Processes, Listening Ports						
endian)																						

Ubuntu Linux

Real-time Anti-Malware requires a compatible file system. See "[Linux file system compatibility](#)" on page 350.

Trend Micro Deep Security On-Premise 20

	Anti-Malware					Web Reputation Service	Firewall	Intrusion Prevention System	Integrity Monitoring							Log Inspection	Application Control	Recommendation Scan	Relay	Scanner	Visio n One (XDR)	FIPS mode
	Real-time				On-demand				Real-time				On-demand									
	Feature Set 11	Process memory scan, Registry scan	Behavior monitoring	Predictive Machine Learning	Feature Set 11			Unencrypted Traffic	SSL Encrypted Traffic	Advanced TLS Traffic Inspection	File Scans 5	Directory Scans	Scans of Running Processes, Listening Ports	File and Directory Scans	Registry Scans	Scans of Running Processes, Listening Ports						
Ubuntu 16.04 (64-bit)	✓		✓ 6	✓ 8	✓	✓	✓	✓	✓		✓		✓	✓		✓	✓	✓	✓	✓	✓	✓
Ubuntu 18.04 (64-bit)	✓		✓ 6	✓ 8	✓	✓	✓	✓	✓	✓ 11	✓		✓	✓		✓	✓	✓	✓	✓	✓	✓
Ubuntu 18.04 (AWS ARM-Based Graviton 2) 10	✓		✓	✓	✓	✓	✓	✓	✓		✓		✓	✓		✓	✓	✓	✓	✓	✓	✓
Ubuntu 20.04	✓		✓ 6	✓ 8	✓	✓	✓	✓	✓	✓ 11	✓		✓	✓		✓	✓	✓	✓	✓	✓	✓

Trend Micro Deep Security On-Premise 20

	Anti-Malware					Web Reputation Service	Firewall	Intrusion Prevention System	Integrity Monitoring							Log Inspection	Application Control	Recommendation Scan	Relay	Scanner	Visio n One (XDR)	FIPS mode
	Real-time				On-demand				Real-time				On-demand									
	Feature Set 11	Process memory scan, Registry scan	Behavior monitoring	Predictive Machine Learning	Feature Set 11			Unencrypted Traffic	SSL Encrypted Traffic	Advanced TLS Traffic Inspection	File Scans 5	Directory Scans	Scans of Running Processes, Listening Ports	File and Directory Scans	Registry Scans	Scans of Running Processes, Listening Ports						
(64-bit)																						
Ubuntu 20.04 (AWS ARM-Based Graviton 2) 10	✓		✓	✓	✓	✓	✓	✓	✓		✓		✓	✓		✓	✓	✓	✓	✓		✓
Ubuntu 22.04 (64-bit)	✓		✓ 6	✓ 8	✓	✓	✓	✓	✓	✓ 20	✓		✓	✓		✓	✓	✓	✓	✓		
Ubuntu 22.04 (AWS ARM-	✓		✓	✓	✓	✓	✓	✓	✓		✓		✓	✓		✓	✓	✓	✓	✓		

Trend Micro Deep Security On-Premise 20

Anti-Malware					Web Reputation Service	Firewall	Intrusion Prevention System	Integrity Monitoring						Log Inspection	Application Control	Recommendation Scan	Relay	Scanner	Visio n One (XDR)	FIPS mode
Real-time				On-demand			Real-time			On-demand										
Feature Set 11	Process memory scan, Registry scan	Behavior monitoring	Predictive Machine Learning	Feature Set 11		Unencrypted Traffic	SSL Encrypted Traffic	Advanced TLS Traffic Inspection	File Scans 5	Directory Scans	Scans of Running Processes, Listening Ports	File and Directory Scans	Registry Scans	Scans of Running Processes, Listening Ports						
Based on Graviton 2) 13																				

Microsoft Windows

For details about which specific Windows 10 update releases are supported, see [Deep Security Support for Windows 10](#) and [Deep Security Support for Windows Server Core](#).

For details about which specific Windows 11 update releases are supported, see [Cloud One - Workload Security and Deep Security Support for Windows 11](#).

Note: For Windows 2012 and later, both Desktop Experience and Server Core installations are supported (any exceptions are mentioned in the table). For Windows Server 2008 and 2008 R2, only Full Installations are supported.

Trend Micro Deep Security On-Premise 20

	Anti-Malware					Web Reputation Service		Firewall	Intrusion Prevention System	Integrity Monitoring							Log Inspection	Application Control	Recommendation Scan	Relay	Scanner	Visi on One (XDR)	FIPS mode	Device Control
	Real-time scan				On-demand scan	Browser Extension				Real-time				On-demand										
	Feature Set 1 1	Process memory scan, Registry scan	Behavior monitoring	Predictive Machine Learning	Feature Set 1 1	Chrome	Edge		Unencrypted Traffic	SSL Encrypted Traffic	Advanced TLS Traffic Inspection	File Scans	Directory Scans	Scans of Running Services, Processes, Listening Ports	File and Directory Scans	Registry Scans	Scans of Running Services, Processes, Listening Ports							
Windows 7 (32-bit)	✓	✓	✓	✓	✓	✓		✓	✓	✓		✓	✓	✓	✓	✓	✓	✓				✓	✓ 8	
Windows 7 (64-bit)	✓	✓	✓	✓	✓	✓		✓	✓	✓		✓	✓	✓	✓	✓	✓	✓		✓		✓	✓ 8	
Windows 7 Embedded (32-bit) 2	✓	✓	✓	✓	✓	✓		✓	✓	✓					✓	✓	✓	✓					✓ 8	

Trend Micro Deep Security On-Premise 20

	Anti-Malware					Web Reputation Service			Firewall	Intrusion Prevention System			Integrity Monitoring					Log Inspection	Application Control	Recommendation Scan	Relay	Scanner	Vison One (XDR)	FIPS mode	Device Control	
	Real-time scan				On-demand scan	Browser Extension							Real-time		On-demand											
	Feature Set 11	Process memory scan, Registry scan	Behavior monitoring	Predictive Machine Learning	Feature Set 11		Chrome	Edge		Unencrypted Traffic	SSL Encrypted Traffic	Advanced TLS Traffic Inspection	File Scans	Directory Scans	Scans of Running Services, Processes, Listening Ports	File and Directory Scans	Registry Scans	Scans of Running Services, Processes, Listening Ports								
Windows 8 (32-bit)	✓	✓	✓	✓	✓	✓			✓	✓	✓		✓	✓	✓	✓	✓	✓	✓				✓		✓ 8	
Windows 8 (64-bit)	✓	✓	✓	✓	✓	✓			✓	✓	✓		✓	✓	✓	✓	✓	✓	✓		✓		✓		✓ 8	
Windows 8.1 (32-bit)	✓	✓	✓	✓	✓	✓			✓	✓	✓		✓	✓	✓	✓	✓	✓	✓				✓		✓ 8	
Windows 8.1	✓	✓	✓	✓	✓	✓			✓	✓	✓		✓	✓	✓	✓	✓	✓	✓				✓		✓ 8	

Trend Micro Deep Security On-Premise 20

	Anti-Malware					Web Reputation Service			Firewall	Intrusion Prevention System			Integrity Monitoring						Log Inspection	Application Control	Recommendation Scan	Relay	Scanner	Vison One (XDR)	FIPS mode	Device Control	
	Real-time scan				On-demand scan	Browser Extension							Real-time			On-demand											
	Feature Set 11	Process memory scan, Registry scan	Behavior monitoring	Predictive Machine Learning	Feature Set 11		Chrome	Edge		Unencrypted Traffic	SSL Encrypted Traffic	Advanced TLS Traffic Inspection	File Scans	Directory Scans	Scans of Running Services, Processes, Listening Ports	File and Directory Scans	Registry Scans	Scans of Running Services, Processes, Listening Ports									
(64-bit)																											
Windows 8.1 Embedded (32-bit) 2	✓	✓	✓	✓	✓	✓			✓	✓	✓					✓	✓	✓	✓					✓		✓ 8	
Windows 10 (32-bit)	✓	✓	✓	✓	✓	✓			✓	✓	✓		✓	✓	✓	✓	✓	✓	✓					✓		✓ 8	
Windows	✓	✓	✓	✓	✓	✓	✓	✓	✓	✓	✓	✓ 16	✓	✓	✓	✓	✓	✓	✓	✓				✓		✓ 8	

Trend Micro Deep Security On-Premise 20

	Anti-Malware					Web Reputation Service		Firewall	Intrusion Prevention System	Integrity Monitoring							Log Inspection	Application Control	Recommendation Scan	Relay	Scanner	Visi on One (XDR)	FIPS mode	Device Control
	Real-time scan				On-demand scan	Browser Extension				Real-time			On-demand											
	Feature Set 1 1	Process memory scan, Registry scan	Behavior monitoring	Predictive Machine Learning	Feature Set 1 1	Chrome	Edge		Unencrypted Traffic	SSL Encrypted Traffic	Advanced TLS Traffic Inspection	File Scans	Directory Scans	Scans of Running Services, Processes, Listening Ports	File and Directory Scans	Registry Scans	Scans of Running Services, Processes, Listening Ports							
s 10 (64-bit)						17	22																	
Windows 10 IoT Enterprise 2019 LTSC (32- and 64-bit) 2	✓	✓	✓	✓	✓	✓		✓	✓	✓		✓	✓	✓	✓	✓	✓	✓		✓	✓	✓	✓ 8	
Windows 10 IoT Enterprise	✓	✓	✓	✓	✓	✓		✓	✓	✓		✓	✓	✓	✓	✓	✓	✓		✓	✓	✓	✓ 8	

Trend Micro Deep Security On-Premise 20

	Anti-Malware					Web Reputation Service			Firewall	Intrusion Prevention System			Integrity Monitoring					Log Inspection	Application Control	Recommendation Scan	Relay	Scanner	Vison One (XDR)	FIPS mode	Device Control	
	Real-time scan				On-demand scan	Browser Extension							Real-time		On-demand											
	Feature Set 11	Process memory scan, Registry scan	Behavior monitoring	Predictive Machine Learning	Feature Set 11		Chrome	Edge		Unencrypted Traffic	SSL Encrypted Traffic	Advanced TLS Traffic Inspection	File Scans	Directory Scans	Scans of Running Services, Processes, Listening Ports	File and Directory Scans	Registry Scans	Scans of Running Services, Processes, Listening Ports								
se 2021 LTSC (64-bit) 2																										
Windows 10 Enterprise multi-session (64-bit)	✓	✓	✓	✓	✓	✓			✓	✓	✓		✓	✓	✓	✓	✓	✓	✓			✓	✓		✓	✓ 8
Windows	✓	✓	✓	✓	✓	✓	✓	✓	✓	✓	✓	✓ 16	✓	✓	✓	✓	✓	✓	✓	✓			✓	✓		✓

Trend Micro Deep Security On-Premise 20

	Anti-Malware					Web Reputation Service		Firewall	Intrusion Prevention System			Integrity Monitoring						Log Inspection	Application Control	Recommendation Scan	Relay	Scanner	Vison One (XDR)	FIPS mode	Device Control
	Real-time scan				On-demand scan	Browser Extension						Real-time			On-demand										
	Feature Set 11	Process memory scan, Registry scan	Behavior monitoring	Predictive Machine Learning	Feature Set 11		Chrome	Edge		Unencrypted Traffic	SSL Encrypted Traffic	Advanced TLS Traffic Inspection	File Scans	Directory Scans	Scans of Running Services, Processes, Listening Ports	File and Directory Scans	Registry Scans	Scans of Running Services, Processes, Listening Ports							
s 11 (64-bit)							17	22																8, 19	
Windows Server 2008 (32-bit)	✓	✓	✓	✓	✓	✓			✓	✓	✓		✓	✓	✓	✓	✓	✓	✓					✓ 17	
Windows Server 2008 (64-bit)	✓	✓	✓	✓	✓	✓			✓	✓	✓		✓	✓	✓	✓	✓	✓	✓			✓		✓ 17	
Windows	✓	✓	✓	✓	✓	✓			✓	✓	✓		✓	✓ 5	✓	✓	✓	✓	✓	✓	✓	✓	✓	✓	

Trend Micro Deep Security On-Premise 20

	Anti-Malware					Web Reputation Service		Firewall	Intrusion Prevention System	Integrity Monitoring								Log Inspection	Application Control	Recommendation Scan	Relay	Scanner	Vison One (XDR)	FIPS mode	Device Control	
	Real-time scan				On-demand scan	Browser Extension				Real-time				On-demand												
	Feature Set 11	Process memory scan, Registry scan	Behavior monitoring	Predictive Machine Learning	Feature Set 11	Chrome	Edge		Unencrypted Traffic	SSL Encrypted Traffic	Advanced TLS Traffic Inspection	File Scans	Directory Scans	Scans of Running Services, Processes, Listening Ports	File and Directory Scans	Registry Scans	Scans of Running Services, Processes, Listening Ports									
s Server 2008 R2 (64-bit)												5											17			
Windows Server 2012 (64-bit)	✓	✓	✓	✓	✓	✓		✓	✓	✓		✓ 3, 5	✓ 3, 5	✓	✓	✓	✓	✓	✓	✓	✓	✓	✓ 3	✓	✓	✓ 17
Windows Server 2012 R2 (64-bit)	✓	✓	✓	✓	✓	✓		✓	✓	✓	✓ 11	✓ 5	✓ 5	✓	✓	✓	✓	✓	✓	✓	✓	✓	✓ 3	✓	✓	✓ 17

Trend Micro Deep Security On-Premise 20

	Anti-Malware					Web Reputation Service		Firewall	Intrusion Prevention System	Integrity Monitoring							Log Inspection	Application Control	Recommendation Scan	Relay	Scanner	Vison One (XDR)	FIPS mode	Device Control
	Real-time scan				On-demand scan	Browser Extension				Real-time				On-demand										
	Feature Set 11	Process memory scan, Registry scan	Behavior monitoring	Predictive Machine Learning	Feature Set 11	Chrome	Edge		Unencrypted Traffic	SSL Encrypted Traffic	Advanced TLS Traffic Inspection	File Scans	Directory Scans	Scans of Running Services, Processes, Listening Ports	File and Directory Scans	Registry Scans	Scans of Running Services, Processes, Listening Ports							
Windows Server 2016 (LTSC, version 1607) (64-bit)	✓	✓	✓	✓	✓	✓	✓ 17	✓ 22	✓	✓	✓	✓ 11	✓ 5	✓ 5	✓	✓	✓	✓	✓	✓	✓	✓	✓	✓ 17
Windows Server Core (SAC, version 1709) (64-bit)	✓	✓	✓	✓	✓	✓			✓	✓	✓	✓ 5	✓ 5	✓	✓	✓	✓	✓	✓	✓	✓	✓	✓	

Trend Micro Deep Security On-Premise 20

	Anti-Malware					Web Reputation Service			Firewall	Intrusion Prevention System	Integrity Monitoring							Log Inspection	Application Control	Recommendation Scan	Relay	Scanner	Vison One (XDR)	FIPS mode	Device Control		
	Real-time scan				On-demand scan	Browser Extension					Real-time				On-demand												
	Feature Set 11	Process memory scan, Registry scan	Behavior monitoring	Predictive Machine Learning	Feature Set 11		Chrome	Edge		Unencrypted Traffic	SSL Encrypted Traffic	Advanced TLS Traffic Inspection	File Scans	Directory Scans	Scans of Running Services, Processes, Listening Ports	File and Directory Scans	Registry Scans	Scans of Running Services, Processes, Listening Ports									
Windows Server 2019 (LTSC, version 1809) (64-bit)	✓	✓	✓	✓	✓	✓	✓ 17	✓ 22	✓	✓	✓	✓ 11	✓ 5	✓ 5	✓	✓	✓	✓	✓	✓	✓	✓	✓	✓	✓	✓ 17	
Windows Server 2022 (LTSC, version 21H2) (64-bit)	✓	✓	✓	✓	✓	✓	✓ 21	✓ 22	✓	✓	✓		✓ 5	✓ 5	✓	✓	✓	✓	✓	✓	✓	✓	✓	✓	✓	✓ 17	

Note: FIPS mode for Windows Desktop platforms might work, but is not supported.

Deep Security Virtual Appliance 20 (NSX) supported guest operating systems

Deep Security Virtual Appliance can protect guest VMs that run any OS shown below, if VMware supports it. For the list of operating systems that VMware supports, see [the VMware Compatibility search tool](#). When using the tool, make sure that:

- **What are you looking for?** is set to **Guest OS**.
- **OS Vendor** is set to an OS shown below.

Note: If you are using [combined mode](#), the agent must also support the OS of the guest VM.

Note: Supported features also vary by NSX license type. For details, see "[VMware deployments with the virtual appliance and NSX](#)" on page 545.

Trend Micro Deep Security On-Premise 20

Anti-Malware					Web Reputation Service	Firewall	Intrusion Prevention System	Integrity Monitoring					Log Inspection	Application Control	Recommendation Scan	Relay	Scanner	Visio n One (XDR)	FIPS mode	
Real-time				On-demand			Real-time			On-demand										
Feature Set 11	Process memory scan, Registry scan	Behavior monitoring	Predictive Machine Learning	Feature Set 11		Unencrypted Traffic	SSL Encrypted Traffic	File Scans	Directory Scans	Scans of Running Services, Processes, Listening Ports	File and Directory Scans	Registry Scans	Scans of Running Services, Processes, Listening Ports							
OS vendors supported by the appliance on NSX Data Center for vSphere (NSX-V)																				
Microsoft Windows	✓		✓	✓	✓	✓	✓	✓					✓						✓	N/A
Red Hat Enterprise Linux					✓	✓	✓													N/A
CentOS Linux					✓	✓	✓													N/A
Oracle Linux					✓	✓	✓													N/A
SUSE Linux					✓	✓	✓													N/A

Trend Micro Deep Security On-Premise 20

	Anti-Malware					Web Reputation Service	Firewall	Intrusion Prevention System	Integrity Monitoring						Log Inspection	Application Control	Recommendation Scan	Relay	Scanner	Visio n One (XDR)	FIPS mode	
	Real-time				On-demand				Real-time			On-demand										
	Feature Set 11	Process memory scan, Registry scan	Behavior monitoring	Predictive Machine Learning	Feature Set 11		Unencrypted Traffic	SSL Encrypted Traffic	File Scans	Directory Scans	Scans of Running Services, Processes, Listening Ports	File and Directory Scans	Registry Scans	Scans of Running Services, Processes, Listening Ports								
Ubuntu Linux						✓	✓	✓														N/A
Debian Linux						✓	✓	✓														N/A
OS vendors supported by the appliance on NSX-T Data Center 3.x (NSX-T 3.x)																						
Microsoft Windows	✓			✓	✓	✓	✓	✓				✓										N/A
Red Hat Enterprise Linux						✓	✓	✓														N/A
CentOS Linux						✓	✓	✓														N/A

Trend Micro Deep Security On-Premise 20

Anti-Malware					Web Reputation Service	Firewall	Intrusion Prevention System	Integrity Monitoring						Log Inspection	Application Control	Recommendation Scan	Relay	Scanner	Visio n One (XDR)	FIPS mode		
Real-time				On-demand				Real-time			On-demand											
Feature Set 11	Process memory scan, Registry scan	Behavior monitoring	Predictive Machine Learning	Feature Set 11		Unencrypted Traffic	SSL Encrypted Traffic	File Scans	Directory Scans	Scans of Running Services, Processes, Listening Ports	File and Directory Scans	Registry Scans	Scans of Running Services, Processes, Listening Ports									
Oracle Linux					✓	✓	✓														N/A	
SUSE Linux					✓	✓	✓															N/A
Ubuntu Linux					✓	✓	✓															N/A
Debian Linux					✓	✓	✓															N/A

Footnotes:

Trend Micro Deep Security On-Premise 20

1

Feature Set 1 includes signature-based file scanning, spyware scanning, and document exploit protection.

2

Because embedded operating systems usually run on custom hardware (for example, on point-of-sale terminals), you should thoroughly test your specific hardware platform prior to deployment in a production environment. Trend Micro tests Windows Embedded platforms in a virtualized environment. If you need to raise a case with Trend Micro Support, try to reproduce the problem in a virtualized environment. If the issue cannot be reproduced in a virtualized environment, and is specific to your custom hardware, Trend Micro Support might require you to provide remote access to it for diagnostics.

Note: Windows 10 IoT was formerly named Windows 10 Embedded, and is therefore considered a Windows Embedded platform.

3

Requires a Full/Desktop Experience installation. Server Core is not supported.

4

Anti-Malware on-demand scans are supported on all Solaris file systems.

5

Supports enhanced real-time integrity monitoring, which uses the application control driver to get information about who changed a monitored file.

6

Requires Deep Security Agent 20.0.0-1822 (20 LTS Update 2021-01-18) or later.

7

Requires Deep Security Agent 20.0.0-2204 (20 LTS Update 2021-04-12) or later.

8

Requires Deep Security Agent 20.0.0-4959 (20 LTS Update 2022-07-04) or later.

Trend Micro Deep Security On-Premise 20

9

Requires Deep Security Agent 20.0.0-2921 (20 LTS Update 2021-08-30) or later.

10

Requires Deep Security Agent 20.0.0-3288 (20 LTS Update 2021-10-28) or later.

11

Requires Deep Security Agent 20.0.0-4185 (20 LTS Update 2022-04-06) or later.

12

Requires Deep Security Agent 20.0.0-5137 (20 LTS Update 2022-07-26) or later.

13

Requires Deep Security Agent 20.0.0-5394 (20 LTS Update 2022-08-29) or later.

14

Requires Deep Security Agent 20.0.0-5761 (20 LTS Update 2022-10-21) or later.

15

Requires Deep Security Agent 20.0.0-5953 (20 LTS Update 2022-11-22) or later.

16

Requires Deep Security Agent 20.0.0-5995 (20 LTS Update 2022-11-28) or later.

17

Requires Deep Security Agent 20.0.0-6313 (20 LTS Update 2023-01-31) or later.

18

Requires Deep Security Agent 20.0.0-6912 (20 LTS Update 2023-05-02) or later.

Trend Micro Deep Security On-Premise 20

19

For Windows 11 systems, the Mobile (MTP/PTP) read-only protocol for Device Control requires Deep Security Agent 20.0.0-5810 (20 LTS Update 2022-10-27) or later.

20

Requires Deep Security Agent 20.0.0-7303 (20 LTS Update 2023-06-28) or later.

21

Requires Deep Security Agent 20.0.0-7719 (20 LTS Update 2023-08-29) or later.

22

Requires Deep Security Agent 20.0.0-7943 (20 LTS Update 2023-09-26) or later.

23

Miracle Linux 8 is supported by Deep Security Agent 20.0.0-7719 (20 LTS Update 2023-08-29) or later for Red Hat Enterprise Linux 8.

24

Requires Deep Security Agent 20.0.0-8438 (20 LTS Update 2023-12-12) or later.

25

Miracle Linux 9 is supported by Deep Security Agent 20.0.0-8137 (20 LTS Update 2023-10-26) or later for Red Hat Enterprise Linux 9.

26

Requires Deep Security Agent 20.0.1-4540 (20 LTS Update 2024-03-20) or later.

Sizing

Sizing guidelines for Deep Security deployments vary by the scale of your network, hardware, and software.

Deep Security Manager sizing

Sizing recommendations for Deep Security Manager vary by how many agents it will have.

Number of agents	Number of CPUs	RAM	JVM process memory	Number of manager nodes	Recommended disk space
<500	2	16 GB	8 GB	2	200 GB
500-1000	4	16 GB	8 GB	2	200 GB
1000-5000	4	16 GB	8 GB	2	200 GB
5000-10000	8	16 GB	12 GB	2	200 GB
10000-20000	8	24 GB	16 GB	2	200 GB

For best performance, it's important to allocate enough Java Virtual Machine (JVM) memory to the Deep Security Manager process. See ["Configure Deep Security Manager memory usage" on page 1693](#).

Recommendation scans are CPU-intensive for the Deep Security Manager. Consider the performance impact when determining how often to run recommendation scans. See ["Manage and run recommendation scans" on page 705](#).

Resource spikes may occur if a large number of virtual machines are rebooted simultaneously and agents re-establish their connection with Deep Security Manager at the same time.

Multiple server nodes

For better availability and scalability, use a load balancer, and install the same version of Deep Security Manager on 2 servers ("nodes"). Connect them to the same database.

Tip: To avoid high load on database servers, don't connect more than two Deep Security Manager nodes to each database server.

Each manager node is capable of all tasks. No node is more important than any of the others. You can log in to any node, and agents, appliances, and relays can connect with any node. If one node fails, other nodes can still provide service, and no data will be lost.

Database sizing

Database CPU, memory, and disk space required varies by:

- Number of protected computers
- Number of platforms where you install Deep Security Agent
- Number of events (logs) recorded per second (related to which security features are enabled)
- How long events are retained
- Size of the database transaction log

Minimum disk space = (2 x Deep Security data size) + transaction log

For example, if your database plus transaction log is 40 GB, you must have 80 GB (40 x 2) of free disk space during database schema upgrades.

To free disk space, delete any unnecessary agent packages for unused platforms (see ["Delete a software package from the Deep Security database" on page 503](#)), transaction logs, and unnecessary event records.

Event retention is configurable. For security events, retention is configured in the policy, individual computer settings, or both. See ["Policies, inheritance, and overrides" on page 701](#) and ["Log and event storage best practices" on page 1129](#).

To minimize disk usage due to events:

Trend Micro Deep Security On-Premise 20

- Store events remotely, not locally. If you need to keep events longer (such as for compliance), forward them to a SIEM or Syslog server and then use pruning to delete the local copy. (See ["Forward Deep Security events to a Syslog or SIEM server" on page 1146.](#))

Note: Some Application Control and Integrity Monitoring operations (Rebuild Baseline, Scan for Integrity Changes, and Scan for Inventory Changes) retain all records locally, and are never pruned or forwarded.

- Patch the protected computer's software *before* you enable Intrusion Prevention. Recommendation scans assign more IPS rules to protect a vulnerable OS. More security events increase local or remote disk usage.
- Disable unnecessary security features that log frequently, such as stateful Firewall for TCP, UDP, and ICMP.

High-traffic computers that use Deep Security Firewall or Intrusion Prevention features might record more events per second, requiring a database with better performance. You might also need to adjust local event retention.

Tip: If you anticipate many Firewall events, consider disabling "Out of allowed policy" events. (See ["Firewall settings" on page 954.](#))

See also ["Deep Security Manager performance features" on page 409.](#)

Database disk space estimates

The table below estimates database disk space with default event retention settings. If the total disk space for the protection modules you enable is more than the "2 or more modules" value, use the smaller estimate. For example, you could deploy 750 agents with Deep Security Anti-Malware, Intrusion Prevention System and Integrity Monitoring. The total of the individual recommendations is 320 GB (20 + 100 + 200) but the "2 or more modules" recommendation is less (300 GB). Therefore, you would estimate 300 GB.

Number of agents	Anti-Malware	Web Reputation Service	Log Inspection	Firewall	Intrusion Prevention System	Application Control	Integrity Monitoring	2 or more modules
1-99	10 GB	15 GB	20 GB	20 GB	40 GB	50 GB	50 GB	100 GB

Trend Micro Deep Security On-Premise 20

Number of agents	Anti-Malware	Web Reputation Service	Log Inspection	Firewall	Intrusion Prevention System	Application Control	Integrity Monitoring	2 or more modules
100-499	10 GB	15 GB	20 GB	20 GB	40 GB	100 GB	100 GB	200 GB
500-999	20 GB	30 GB	50 GB	50 GB	100 GB	200 GB	200 GB	300 GB
1000-9999	50 GB	60 GB	100 GB	100 GB	200 GB	500 GB	400 GB	600 GB
10,000-20,000	100 GB	120 GB	200 GB	200 GB	500 GB	750 GB	750 GB	1 TB

Database disk space also increases with the number of separate Deep Security Agent platforms. For example, if you have 30 agents (maximum 5 versions per agent platform), this increases the database size by approximately 5 GB.

Deep Security Agent and Relay sizing

Guidance for processor, memory and disk space allocation has been moved to [system requirements](#).

Estimated Agent resource consumption

The tables below show the estimated resource consumption for deployments using commonly used feature combinations.

Windows Agent

Modules enabled								RAM
Anti-Malware	Web Reputation Service	Activity Monitoring	Application Control	Integrity Monitoring	Log Inspection	Firewall	Intrusion Prevention	
✓								156 MB
							✓	148 MB
✓	✓	✓						150 MB
✓	✓	✓					✓	308 MB
✓				✓	✓		✓	280 MB
✓	✓	✓	✓	✓	✓		✓	390 MB
✓	✓	✓	✓	✓	✓	✓	✓	361 MB

Linux Agent

Modules enabled								RAM
Anti-Malware	Web Reputation Service	Activity Monitoring	Application Control	Integrity Monitoring	Log Inspection	Firewall	Intrusion Prevention	
✓								315 MB
						✓	✓	172 MB

Modules enabled								RAM
Anti-Malware	Web Reputation Service	Activity Monitoring	Application Control	Integrity Monitoring	Log Inspection	Firewall	Intrusion Prevention	
✓							✓	399 MB
✓	✓	✓						312 MB
✓	✓	✓					✓	448 MB
✓				✓	✓		✓	413 MB
✓	✓	✓		✓	✓		✓	492 MB
✓	✓	✓	✓	✓	✓		✓	538 MB

Deep Security Virtual Appliance sizing

The Deep Security Virtual Appliance software is delivered as a series of OVF files, with each one being allocated a different set of resources for different deployment sizes and types. You'll need to choose the OVF file that supports your environment the best. See the table below for details.

See also "[Deep Security Virtual Appliance memory allocation](#)" on page 628.

OVF file	vCPUs	vRAM	Disk space	Virtual hardware version	NSX type	Maximum protected VMs	DPDK support?
dsva.ovf	2	4 GB	20 GB	13 (ESXi 6.5+)	NSX-V	10	no
dsva-small.ovf	4	8 GB	20 GB	13 (ESXi 6.5+)	NSX-V	50	no
dsva-medium.ovf	6	16 GB	20 GB	13 (ESXi 6.5+)	NSX-V	200	no

OVF file	vCPUs	vRAM	Disk space	Virtual hardware version	NSX type	Maximum protected VMs	DPDK support?
dsva-large.ovf	8	24 GB	20 GB	13 (ESXi 6.5+)	NSX-V	300	no
dsva-<20.x.x-xxxx>-C2M4-small.ovf	2	4 GB	20 GB	13 (ESXi 6.5+)	NSX-T	10	no
dsva-<20.x.x-xxxx>-C4M8-small.ovf	4	8 GB	20 GB	13 (ESXi 6.5+)	NSX-T	10 with DPDK enabled 50 with DPDK disabled	yes*
dsva-<20.x.x-xxxx>-C6M16-medium.ovf	6	16 GB	20 GB	13 (ESXi 6.5+)	NSX-T	200 with DPDK disabled	no
dsva-<20.x.x-xxxx>-C8M16-medium.ovf	8	16 GB	20 GB	13 (ESXi 6.5+)	NSX-T	150 with DPDK enabled	yes*
dsva-<20.x.x-xxxx>-C8M24-large.ovf	8	24 GB	20 GB	13 (ESXi 6.5+)	NSX-T	300 with DPDK disabled	no
dsva-<20.x.x-xxxx>-C12M24-large.ovf	12	24 GB	20 GB	13 (ESXi 6.5+)	NSX-T	300 with DPDK enabled	yes*

* To enable DPDK mode, see ["Configure DPDK mode" on page 622](#).

Note:

Requirements above can vary by feature:

- [Integrity Monitoring](#): For larger VDI deployments (more than 50 VMs per ESXi host), use Deep Security Agent instead, not Deep Security Virtual Appliance.
- [Anti-Malware](#): Requirements may vary by version of VMware Guest Introspection. Use the [VMware Configuration Maximum tool](#).
- [Firewall](#), [Web Reputation](#), or [Intrusion Prevention](#): Requirements may vary by version of VMware Network Introspection (NSX). See the [VMware Configuration Maximums tool](#).

Tip:

Patch the protected computer's software *before* you enable Intrusion Prevention. Recommendation scans assign more IPS rules to protect a vulnerable OS. This

increases the appliance's memory usage. For example, the table below shows how vRAM usage can increase by the number of IPS rules on 300 VMs (full, linked or instant clones as virtual desktop infrastructure (VDI)).

Number of Intrusion Prevention rules	Appliance vRAM usage
350-400	24 GB
500-600	30 GB
600-700	40 GB
700+	50 GB+

If the appliance is protecting a large number of VMs, and recommendation scans fail due to timeout errors, see ["Manage and run recommendation scans" on page 705](#) to increase timeout values.

Deep Security Manager performance features

Performance profiles

Deep Security Manager uses an optimized concurrent job scheduler that considers the impacts of each job on CPU, database and agents or appliances. By default, new installations use the "Aggressive" performance profile which is optimized for a dedicated manager. If the Deep Security Manager is installed on a system with other resource-intensive software it may be preferable to use the "Standard" performance profile. The performance profile can be changed by navigating to **Administration > Manager Nodes**. From this screen select a manager node and open the **Properties** window. From here the performance profile can be changed via the menu.

The performance profile also controls the number of agent- or appliance-initiated connections that the manager will accept. The default of each of the performance profiles effectively balances the amount of accepted, delayed and rejected heartbeats.

Low disk space alerts

Low disk space on the database

If the Deep Security Manager receives a "disk full" error message from the database, it will start to write events to its own hard drive and will send an email message to all users informing them of the situation. This behavior is not configurable.

If you are running multiple manager nodes, the events will be written to the disk of whichever node is handling the event. (For more information on running multiple nodes, see ["Install Deep Security Manager on multiple nodes" on page 488.](#))

Once the disk space issue on the database has been resolved, the manager will write the locally stored data to the database.

Low disk space on the manager

If the available disk space on the computer where Deep Security Manager is installed falls below 10%, the manager generates a "Low Disk Space" alert. This alert is part of the normal alert system and is configurable like any other. (For more information, see ["Configure alerts" on page 1263.](#))

If you are running multiple manager nodes, the node will be identified in the alert.

When the manager's available disk space falls below 5 MB, the manager will send an email message to all users and the manager will shut down. The manager cannot be restarted until the available disk space is greater than 5 MB.

You must restart the manager manually.

If you are running multiple nodes, only the node that has run out of disk space will shut down. The other manager nodes will continue operating.

Port numbers, URLs, and IP addresses

This document provides information on Deep Security default port numbers, URLs, IP addresses, and protocols. If a port, URL or IP address is configurable, a link is provided to the relevant configuration page.

- ["Deep Security port numbers" below](#)
- ["Deep Security URLs" on page 416](#)

Note: If your network uses a proxy or load balancer, you can configure Deep Security to connect to it instead of directly to the components listed on this page. For details, see ["Configure proxies" on page 1404](#) and ["Load Balancers" on page 1557](#).

Note: In addition to the ports on this page, Deep Security uses [ephemeral ports](#) when opening a socket (source port). Under rare circumstances these may be blocked, causing connectivity issues. For details, see ["Blocked port" on page 1376](#).

Deep Security port numbers

The following diagram shows the default ports in a Deep Security system:

Trend Micro Deep Security On-Premise 20

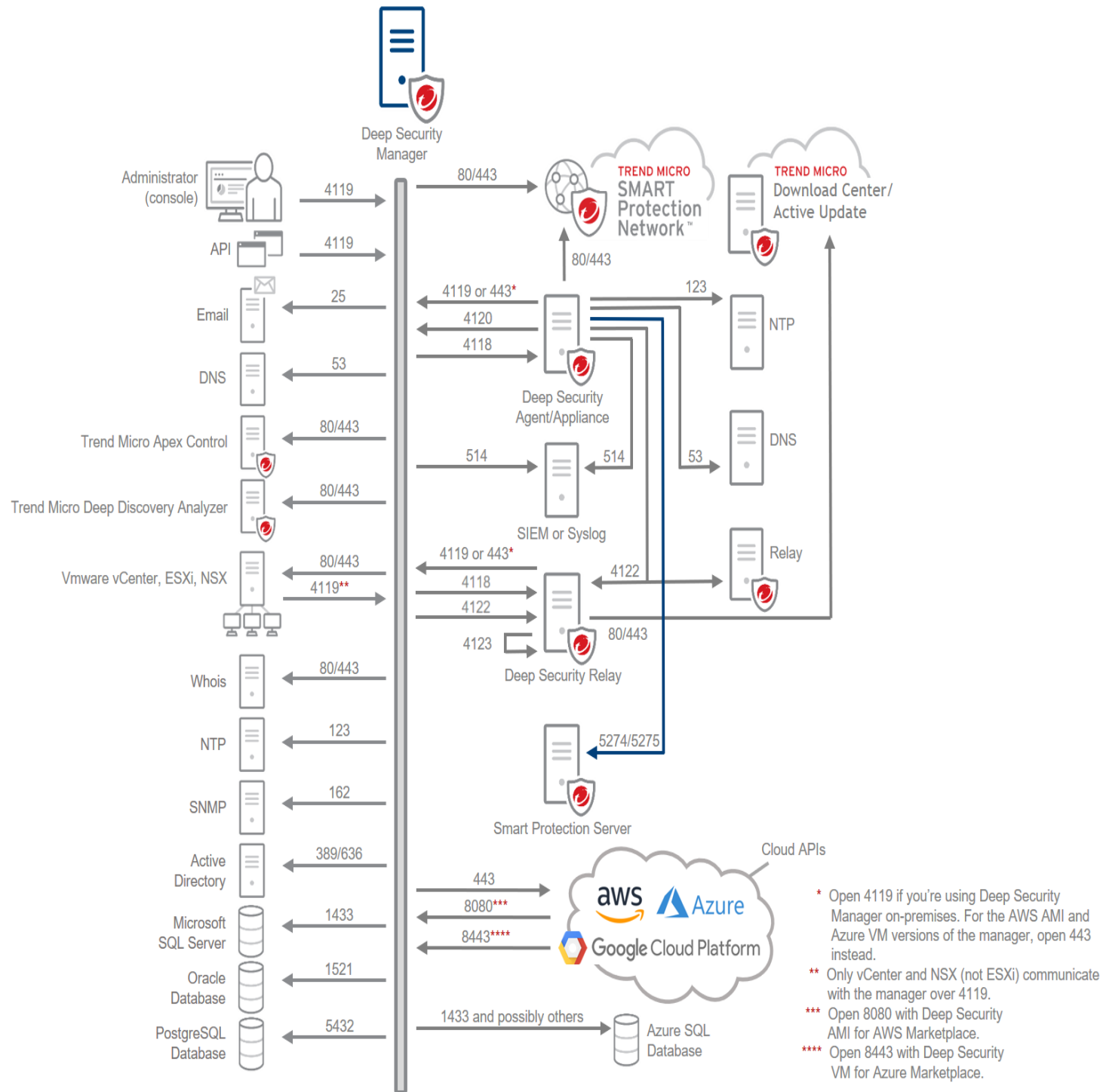

The following table provides details about the default ports. In this table, ports listed as mandatory must be opened to ensure the proper functioning of the Deep Security system; ports listed as optional may be opened depending on the feature or component you want to deploy; port numbers are referred to as ports.

Port type	Default port number and protocol
Deep Security Agent /Appliance listening (inbound) port	<p>Mandatory port:</p> <ul style="list-style-type: none"> 4118/HTTPS – Deep Security Agent/appliance port. Leave 4118/HTTPS closed if you plan on using agent-initiated communication. Only open it if you plan on using bidirectional or manager-initiated communication. By default, bidirectional communication is used, which is why 4118/HTTPS is listed here as 'mandatory'. See "Agent-manager communication" on page 1448 for details.
Deep Security Agent /Appliance outbound ports	<p>Mandatory ports:</p> <ul style="list-style-type: none"> 53/DNS over TCP or UDP – DNS server port 80/HTTP, 443/HTTPS – Smart Protection Network port, Smart Protection Server for File Reputation 123/NTP over UDP – NTP server port 4119/HTTPS – Deep Security Manager GUI and API port. This port is also used to download agent software when using deployment scripts. 4120/HTTPS – Deep Security Manager agent heartbeat port. Allow 4120/HTTPS if you are using bidirectional or agent-initiated communication. Close it if you are using manager-initiated communication. By default, bidirectional communication is used, which is why 4120/HTTPS is listed here as 'mandatory'. See "Agent-manager communication" on page 1448 for details. 4122/HTTPS – Deep Security Relay port. <p>Note: When using the AWS AMI and Azure VM versions of the manager, open port 443 instead of port 4119.</p> <p>Optional ports:</p> <ul style="list-style-type: none"> 514/Syslog over UDP – SIEM or syslog server port. Allow port 514 if you want the agent to send its security events directly to your SIEM or syslog

Port type	Default port number and protocol
	<p>server. The port number is configurable in the manager.</p> <ul style="list-style-type: none"> • 5274/HTTP, 5275/HTTPS – Smart Protection Server ports for Web Reputation. Ports 5274 and 5275 are only required for Web Reputation, not Firewall. Allow ports 5274 and 5275 if you are hosting a Smart Protection Server in your local network or Virtual Private Network (VPC), instead of having your agents/appliance connect to the cloud-based Smart Protection Network over 80/HTTP and 443/HTTPS. For details, see the Smart Protection Server documentation, or "Integrate with Smart Protection Server" on page 1894.
Deep Security Relay listening (inbound) ports	<ul style="list-style-type: none"> • Allow the agent listening port, since it applies to the relay too • 4122/HTTPS – Deep Security Replay port. • 4123 – This port is for communication between the agent and its own internal relay.
Deep Security Relay outbound ports	<ul style="list-style-type: none"> • 80/HTTP, 443/HTTPS – Trend Micro Update Server/Active Update and Download Center ports • 4119/HTTPS – Deep Security Manager GUI and API port. • 4122 – Port of other Deep Security Relays.
Deep Security Manager listening (inbound) ports	<p>Mandatory ports:</p> <ul style="list-style-type: none"> • 4119/HTTPS – Deep Security Manager GUI and API port. This port is also used to download agent software when using deployment scripts.. Also used for shared and global Application Control rulesets, unless your rulesets are downloaded from a relay. • 4120/HTTPS – Deep Security Manager agent heartbeat port. Allow 4120/HTTPS if you are using bidirectional or agent-initiated communication. Close it if you are using manager-initiated communication. By default, bidirectional communication is used, which is why 4120/HTTPS is listed here as 'mandatory'. See "Agent-manager communication" on page 1448 for details.
Deep	Mandatory ports:

Port type	Default port number and protocol
Security Manager (outbound ports)	<ul style="list-style-type: none"> • 53/DNS over TCP or UDP – DNS server port • 80/HTTP, 443/HTTPS – These ports are used by various Deep Security cloud services, Smart Protection Network services, Trend Micro Apex Central, Deep Discovery Analyzer, VMware components (vCenter, ESXi, NSX), Whois server, AWS API, and Azure API, and Google Cloud Platform (GCP) API) 80 and 443 are configurable depending on the service being accessed. You can configure Trend Micro Apex Central and Deep Discovery Analyzer ports, NSX and vCenter ports, and the Whois port. • 123/NTP over UDP – NTP server port number. The NTP server can be Trend Micro Apex Central. • Deep Security Manager's database server port numbers. Select from: <ul style="list-style-type: none"> • 1433/SQL over TCP or UDP – Microsoft SQL database port • 1433/SQL over TCP – Azure SQL Database port • 1521/SQL over TCP – Oracle database port • 5432/SQL over TCP – PostgreSQL database port • 11000-11999/SQL and 14000-14999/SQL over TCP – These are additional Azure SQL Database ports. Allow ports 11000-11999 and 14000-14999—in addition to 1433—if you are using Azure SQL Database and your Deep Security Manager runs <i>within</i> the Azure cloud boundary. If your manager runs <i>outside</i> the Azure cloud boundary, you only need to allow port 1433 to Azure SQL Database. For details, see this Azure document. • 4118/HTTPS – Deep Security Agent/appliance port. Leave 4118/HTTPS closed if you plan on using agent-initiated communication. Only open it if you plan on using bidirectional or manager-initiated communication. By default, bidirectional communication is used, which is why 4118/HTTPS is listed here as 'mandatory'. See "Agent-manager communication" on page 1448 for details. • 4122/HTTPS – Deep Security Relay port. <p>Optional ports:</p> <ul style="list-style-type: none"> • 25/SMTP over TCP – Email server port. Allow port 25 if you want email notifications. 25 is configurable in the manager. • 162/SNMP over TCP or UDP – SNMP manager port. Allow port 162 if you want to "Forward system events to a remote computer via SNMP" on

Port type	Default port number and protocol
	<p>page 1263.</p> <ul style="list-style-type: none"> • 514/Syslog over UDP – SIEM or syslog server port. Allow port 514 if you want to forward Deep Security events to an external SIEM or syslog server. 514 is configurable in the manager. • 389/LDAP, 636/LDAPS, both over TCP – Active Directory ports. Allow ports 389 and 636 if you want to add computers from Active Directory to the manager. 389 and 636 are configurable in the manager if your Active Directory server uses a different port. • 4119 – Allow port 4119 if you are using Deep Security Virtual Appliance. This port is used to obtain the OVF during Deep Security Virtual Appliance deployment.

Deep Security URLs

To restrict the URLs that are allowed in your environment, you need to ensure that your firewall allows traffic from the source to the destinations, as described in the following table. For each FQDN, you have to allow access to its associated HTTP and HTTPS URLs. For example, for the FQDN `files.trendmicro.com`, allow access to `http://files.trendmicro.com:80` and `https://files.trendmicro.com:443`.

Source	Destination server or service name	Destination fully-qualified domain name (FQDN)
API clients	Deep Security APIs	<ul style="list-style-type: none"> • <manager FQDN or IP>:4119/webservice/Manager?WSDL • <manager FQDN or IP>:4119/api • <manager FQDN or IP>:4119/rest
Legacy REST API clients	Deep Security legacy REST API's Status Monitoring API	<ul style="list-style-type: none"> • <manager FQDN or IP>:4119/rest/status/manager/ping
Deep Security Manager, Deep Security Agent/Appliance, Deep Security Relay	Download Center or web server	<ul style="list-style-type: none"> • files.trendmicro.com

Source	Destination server or service name	Destination fully-qualified domain name (FQDN)
	Hosts software.	
Deep Security Manager	Smart Protection Network - Certified Safe Software Service (CSSS) Used for event tagging with Integrity Monitoring .	<ul style="list-style-type: none"> • grid-global.trendmicro.com
Deep Security Manager	Trend Micro Vision One Used to " Integrate with Trend Micro Vision One (XDR) " on page 1901.	<ul style="list-style-type: none"> • *.xdr.trendmicro.com:443 • *.xbc.trendmicro.com:443 • *.mgcp.trendmicro.com:443 • *.manage.trendmicro.com:443 • *.xdr.trendmicro.co.jp:443 (for Japanese regions)
Deep Security Agent/Appliance	Smart Protection Network - Global Census Service Used for behavior monitoring , and predictive machine learning .	<p>20.0 and later agents/appliances connect to:</p> <ul style="list-style-type: none"> • ds2000-en-census.trendmicro.com • ds2000-jp-census.trendmicro.com <p>12.0 and later agents/appliances connect to:</p> <ul style="list-style-type: none"> • ds1200-en-census.trendmicro.com • ds1200-jp-census.trendmicro.com <p>11.0 and later agents/appliances connect to:</p> <ul style="list-style-type: none"> • ds1100-en-census.trendmicro.com

Source	Destination server or service name	Destination fully-qualified domain name (FQDN)
		<ul style="list-style-type: none"> • ds1100-jp-census.trendmicro.com <p>10.2 and 10.3 agents/appliances connect to:</p> <ul style="list-style-type: none"> • ds1020-en-census.trendmicro.com • ds1020-jp-census.trendmicro.com • ds1020-sc-census.trendmicro.com <p>10.1 and 10.0 agents/appliances connect to:</p> <ul style="list-style-type: none"> • ds1000-en.census.trendmicro.com • ds1000-jp.census.trendmicro.com • ds1000-sc.census.trendmicro.com • ds1000-tc.census.trendmicro.com
<p>Deep Security Agent/Appliance</p>	<p>Smart Protection Network - Good File Reputation Service</p> <p>Used for behavior monitoring, predictive machine learning, and process memory scans.</p>	<p>20.0 and later agents/appliances connect to:</p> <ul style="list-style-type: none"> • deepsec20-en.gfrbridge.trendmicro.com • deepsec20-jp.gfrbridge.trendmicro.com <p>12.0 and later agents/appliances connect to:</p> <ul style="list-style-type: none"> • deepsec12-en.gfrbridge.trendmicro.com • deepsec12-jp.gfrbridge.trendmicro.com <p>11.0 and later agents/appliances connect to:</p>

Source	Destination server or service name	Destination fully-qualified domain name (FQDN)
		<ul style="list-style-type: none"> • deepsec11-en.gfrbridge.trendmicro.com • deepsec11-jp.gfrbridge.trendmicro.com <p>10.2 and 10.3 agents/appliances connect to:</p> <ul style="list-style-type: none"> • deepsec102-en.gfrbridge.trendmicro.com • deepsec102-jp.gfrbridge.trendmicro.com <p>10.1 and 10.0 agents/appliances connect to:</p> <ul style="list-style-type: none"> • deepsec10-en.grid-gfr.trendmicro.com • deepsec10-jp.grid-gfr.trendmicro.com • deepsec10-cn.grid-gfr.trendmicro.com
Deep Security Agent/Appliance	Smart Protection Network - Smart Feedback	<p>20.0 and later agents/appliances connect to:</p> <ul style="list-style-type: none"> • ds200-en.fbs25.trendmicro.com • ds200-jp.fbs25.trendmicro.com <p>12.0 and later agent/appliance connect to:</p> <ul style="list-style-type: none"> • ds120-en.fbs25.trendmicro.com • ds120-jp.fbs25.trendmicro.com <p>11.0 and later agents/appliances connect to:</p> <ul style="list-style-type: none"> • deepsecurity1100-en.fbs25.trendmicro.com

Source	Destination server or service name	Destination fully-qualified domain name (FQDN)
		<ul style="list-style-type: none"> • deepsecurity1100-jp.fbs25.trendmicro.com <p>10.0 agents/appliances connect to:</p> <ul style="list-style-type: none"> • deepsecurity1000-en.fbs20.trendmicro.com • deepsecurity1000-jp.fbs20.trendmicro.com • deepsecurity1000-sc.fbs20.trendmicro.com
<p>Deep Security Agent/Appliance</p>	<p>Smart Protection Network - Smart Scan Service</p>	<p>20.0 and later agents/appliances connects to:</p> <ul style="list-style-type: none"> • ds20.icrc.trendmicro.com • ds20-jp.icrc.trendmicro.com <p>12.0 and later agents/appliances connect to:</p> <ul style="list-style-type: none"> • ds120.icrc.trendmicro.com • ds120-jp.icrc.trendmicro.com <p>11.0 and later agents/appliances connect to:</p> <ul style="list-style-type: none"> • ds110.icrc.trendmicro.com • ds110-jp.icrc.trendmicro.com <p>10.2 and 10.3 agents/appliances connect to:</p> <ul style="list-style-type: none"> • ds102.icrc.trendmicro.com • ds102-jp.icrc.trendmicro.com

Source	Destination server or service name	Destination fully-qualified domain name (FQDN)
		<ul style="list-style-type: none"> • ds102-sc.icrc.trendmicro.com.cn <p>10.1 and 10.0 agents/appliances connect to:</p> <ul style="list-style-type: none"> • ds10.icrc.trendmicro.com • ds10.icrc.trendmicro.com/tmcss/ • ds10-jp.icrc.trendmicro.com/tmcss/ • ds10-sc.icrc.trendmicro.com.cn/tmcss/ <p>9.6 and 9.5 agents/appliances connect to:</p> <ul style="list-style-type: none"> • iaufdbk.trendmicro.com • ds96.icrc.trendmicro.com • ds96-jp.icrc.trendmicro.com • ds96-sc.icrc.trendmicro.com.cn • ds95.icrc.trendmicro.com • ds95-jp.icrc.trendmicro.com • ds95-sc.icrc.trendmicro.com.cn
<p>Deep Security Agent/Appliance</p>	<p>Smart Protection Network - predictive machine learning</p>	<p>20.0 and later agents/appliances connect to:</p> <ul style="list-style-type: none"> • ds20-en-b.trx.trendmicro.com • ds20-jp-b.trx.trendmicro.com • ds20-en-f.trx.trendmicro.com • ds20-jp-f.trx.trendmicro.com

Source	Destination server or service name	Destination fully-qualified domain name (FQDN)
		<p>12.0 and later agents/appliances connect to:</p> <ul style="list-style-type: none"> • ds120-en-b.trx.trendmicro.com • ds120-jp-b.trx.trendmicro.com • ds120-en-f.trx.trendmicro.com • ds120-jp-f.trx.trendmicro.com <p>11.0 and later agents/appliances connect to:</p> <ul style="list-style-type: none"> • ds110-en-b.trx.trendmicro.com • ds110-jp-b.trx.trendmicro.com • ds110-en-f.trx.trendmicro.com • ds110-jp-f.trx.trendmicro.com <p>10.2 and 10.3 agents/appliances connect to:</p> <ul style="list-style-type: none"> • ds102-en-f.trx.trendmicro.com • ds102-jp-f.trx.trendmicro.com • ds102-sc-f.trx.trendmicro.com
<p>Deep Security Agent/Appliance</p>	<p>Smart Protection Network - Web Reputation Service</p>	<p>20.0 and later agents/appliances connect to:</p> <ul style="list-style-type: none"> • ds20-0-en.url.trendmicro.com • ds20-0-jp.url.trendmicro.com <p>12.0 and later agents/appliances connect to:</p>

Source	Destination server or service name	Destination fully-qualified domain name (FQDN)
		<ul style="list-style-type: none"> • ds12-0-en.url.trendmicro.com • ds12-0-jp.url.trendmicro.com <p>The 11.0 and later agents/appliances connect to:</p> <ul style="list-style-type: none"> • ds11-0-en.url.trendmicro.com • ds11-0-jp.url.trendmicro.com <p>10.2 and 10.3 agents/appliances connect to:</p> <ul style="list-style-type: none"> • ds10-2-en.url.trendmicro.com • ds10-2-sc.url.trendmicro.com.cn • ds10-2-jp.url.trendmicro.com <p>10.1 and 10.0 agents/appliances connect to:</p> <ul style="list-style-type: none"> • ds100-en.url.trendmicro.com • ds100-sc.url.trendmicro.com • ds100-jp.url.trendmicro.com <p>9.6 and 9.5 agents/appliances connect to:</p> <ul style="list-style-type: none"> • ds96-en.url.trendmicro.com • ds96-jp.url.trendmicro.com • ds95-en.url.trendmicro.com • ds95-jp.url.trendmicro.com

Source	Destination server or service name	Destination fully-qualified domain name (FQDN)
Deep Security Manager	Help and support	<ul style="list-style-type: none"> • help.deepsecurity.trendmicro.com • success.trendmicro.com/product-support/deep-security
Deep Security Manager	Licensing and registration servers	<ul style="list-style-type: none"> • licenseupdate.trendmicro.com • clp.trendmicro.com • olr.trendmicro.com
Deep Security Manager	News feed	<ul style="list-style-type: none"> • news.deepsecurity.trendmicro.com • news.deepsecurity.trendmicro.com/news.atom • news.deepsecurity.trendmicro.com/news_ja.atom
Browser on Deep Security Agent computers, and the computer used to log in to Deep Security Manager	Site Safety	<p>Optional. There are links to the URLs below within the manager UI and on the agent's 'Your administrator has blocked access to this page for your safety' page.</p> <ul style="list-style-type: none"> • sitesafety.trendmicro.com • jp.sitesafety.trendmicro.com
Deep Security Relay, and Deep Security Agent/Appliance	Update Server (also called Active Update) Hosts security updates.	<ul style="list-style-type: none"> • iaus.activeupdate.trendmicro.com • iaus.trendmicro.com • ipv6-iaus.trendmicro.com • ipv6-iaus.activeupdate.trendmicro.com

Source	Destination server or service name	Destination fully-qualified domain name (FQDN)
<p>Deep Security Manager</p>	<p>AWS and Azure URLs</p> <p>Used for adding AWS accounts, Azure accounts and Google Cloud Platform (GCP) service accounts to Deep Security Manager.</p>	<p>AWS URLs</p> <ul style="list-style-type: none"> • URLs of AWS endpoints listed on this AWS page, under these headings: <ul style="list-style-type: none"> • Amazon Elastic Compute Cloud (Amazon EC2) • AWS Security Token Service (AWS STS) • AWS Identity and Access Management (IAM) • Amazon WorkSpaces <p>Azure URLs</p> <ul style="list-style-type: none"> • login.windows.net (authentication) • login.microsoftonline.com (authentication) • management.azure.com (Azure API) • login.microsoftonline.us (authentication to Azure Government) • management.usgovcloudapi.net (authentication to Azure Government) • management.core.windows.net (Azure API) <p>Note: The management.core.windows.net URL is only required if you used the v1 Azure connector available in Deep Security Manager 9.6 to add an Azure account to the manager. With Deep Security Manager 10.0 and later, a v2 connector is used, and does not require access to this URL.</p>

Source	Destination server or service name	Destination fully-qualified domain name (FQDN)
		GCP URLs <ul style="list-style-type: none"> • oauth2.googleapis.com (authentication) • googleapis.com (GCP API) • cloudresourcemanager.googleapis.com (GCP API)
Deep Security Manager	Telemetry service Used for protected " Deep Security Product Usage Data Collection " on page 1845.	<ul style="list-style-type: none"> • telemetry.deepsecurity.trendmicro.com
Deep Security Manager	Activation Used for activating Deep Security Manager with an activation code and for integrating with Trend Vision One .	<ul style="list-style-type: none"> • flywheel.xdr.trendmicro.com

Get Started

Check digital signatures on software packages

Before installing Deep Security, check the digital signature on the software ZIP packages and installer files. A correct digital signature indicates that the software is authentically from Trend Micro and has not been corrupted or tampered with.

- ["Check the signature on software ZIP packages" below](#)
- ["Check the signature on installer files \(EXE, MSI, RPM or DEB files\)" on page 429](#)

You can also validate the software's checksums, as well as the security updates' and Deep Security Agent modules' digital signature. See ["How Deep Security validates update integrity" on page 1610](#) and ["Configure Linux Secure Boot for agents" on page 504](#).

Check the signature on software ZIP packages

The Deep Security Agent, Deep Security Virtual Appliance, and online help are made available in ZIP packages. These packages are digitally signed. You can check the digital signature on the ZIP file in the following ways:

By importing or exporting the ZIP to or from the manager

Import or export a ZIP file following the instructions in ["Import agent software" on page 499](#) or ["Export the agent installer" on page 501](#).

On import or export, the manager checks the digital signature on the ZIP file. If the signature is valid, the manager allows the import or export to proceed. If the signature is invalid or missing, the manager disallows the action, deletes the ZIP, and logs an event.

By viewing the ZIP's properties file

1. Log in to Deep Security Manager.
 2. Click **Administration** at the top.
-

3. On the left, expand **Updates > Software > Local**.
4. Find the ZIP package whose digital signature you want to check and double-click it. If it is not there, [import it](#).

The **Properties** page for the ZIP file opens, and the manager checks the digital signature. If the signature is valid, you will see a green check mark in the **Signature** field, as shown in the following illustration. If the signature is not valid or does not exist, the manager deletes the ZIP and logs an event.

General Information

Name: Agent-Windows-12.5.0-713.i386.zip

Platform: Microsoft Windows (32 bit)

Version: 12.5.0.713

Signature: Signed By Trend Micro, Inc.

Fingerprint: C1:7F:D9:DF:1A:BE:48:DF:D2:A4:9F:2F:E6:37:71:76:52:FA:A1:FB

Imported: March 19, 2020 15:51

Notes:

OK Cancel Apply

By using jarsigner

Use the jarsigner Java utility to check a signature on a ZIP when you cannot check it

through the manager. For example, suppose you obtained an agent ZIP package from a non-manager source, such as the [Deep Security Software](#) page, and then wanted to install the agent manually. In this scenario, you would use the jarsigner utility since the manager is not involved.

To check a signature using jarsigner:

1. Install the latest [Java Development Kit](#) on your computer.
2. Download the ZIP.
3. Use the [jarsigner utility](#) within the JDK to check the signature. The command is:

```
jarsigner -verify -verbose -certs -strict <ZIP_file>
```

Example:

```
jarsigner -verify -verbose -certs -strict Agent-RedHat_EL7-11.2.0-124.x86_64.zip
```

4. Read any errors as well as the content of the certificate to determine if the signature can be trusted.

Check the signature on installer files (EXE, MSI, RPM or DEB files)

The installers for the Deep Security Agent, Deep Security Manager, and Deep Security Notifier are digitally signed using RSA. The installer is an EXE or MSI file on Windows, an RPM file on Linux operating systems (Amazon, CloudLinux, Oracle, Red Hat, and SUSE), or a DEB file on Debian and Ubuntu.

Note: The instructions below describe how to check a digital signature manually on an installer file. If you'd like to automate this check, you can include it in your agent deployment scripts. For more on deployment scripts, see ["Use deployment scripts to add and protect computers" on page 1790](#).

Follow the instructions that correspond to the type of installer file you want to check.

- ["Check the signature on an EXE or MSI file" on the next page](#)
- ["Check the signature on an RPM file" on the next page](#)

- ["Check the signature on a DEB file" on page 432](#)

Check the signature on an EXE or MSI file

1. Right-click the EXE or MSI file and select **Properties**.
2. Click the **Digital Signatures** tab to check the signature.

Check the signature on an RPM file

First, install GnuPG

Install [GnuPG](#) on the agent computer where you intend to check the signature, if it is not already installed. This utility includes the GPG command-line tool, which you need in order to import the signing key and check the digital signature.

Note: GnuPG is installed by default on most Linux distributions.

Next, import the signing key

1. Look for the `3trend_public.asc` file in the root folder of the agent's ZIP file. The ASC file contains a GPG public signing key that you can use to verify the digital signature.
2. Optionally, verify the SHA-256 hash digest of the **ASC** file using any hashing utility. The hash is:

```
c59caa810a9dc9f4ecdf5dc44e3d1c8a6342932ca1c9573745ec9f1a82c118d7
```

(for Agent version 20.0.0-2593 or earlier)

```
bd3b00763db11cee2a6b990428d506f11cf86c68354388fe9cc41fa7e6c9ddae
```

(for Agent version 20.0.0-2971 or later)

```
7a7509c5458c762f6a341820a93e09f0f1b9dd3258608753e18d26575e9c730f
```

(for Agent version 20.0.1-3180 or later)

3. On the agent computer where you intend to check the signature, import the ASC file. Use this command:

Note: Commands are case-sensitive.

```
gpg --import 3trend_public.asc
```

The following messages appear:

```
gpg: directory `/home/build/.gnupg' created
```

```
gpg: new configuration file `/home/build/.gnupg/gpg.conf'
created
```

```
gpg: WARNING: options in `/home/build/.gnupg/gpg.conf' are not
yet active during this run
```

```
gpg: keyring `/home/build/.gnupg/secring.gpg' created
```

```
gpg: keyring `/home/build/.gnupg/pubring.gpg' created
```

```
gpg: /home/build/.gnupg/trustdb.gpg: trustdb created
```

```
gpg: key E1051CBD: public key "Trend Micro (trend linux sign)
<alloftrendetscodesign@trendmicro.com>" imported
```

```
gpg: Total number processed: 1
```

```
gpg: imported: 1 (RSA: 1)
```

4. Export the GPG public signing key from the ASC file:

```
gpg --export -a 'Trend Micro' > RPM-GPG-KEY-CodeSign
```

5. Import the GPG public signing key to the RPM database:

```
sudo rpm --import RPM-GPG-KEY-CodeSign
```

6. Verify that the GPG public signing key has been imported:

```
rpm -qa gpg-pubkey*
```

7. The fingerprints of imported GPG public keys appear. The Trend Micro one is:

```
gpg-pubkey-e1051cbd-5b59ac99 (For Agent version include or before 20.0.0-
2593)
```

```
gpg-pubkey-e1051cbd-6030cc3a (For Agent version include or after 20.0.0-
2971)
```

The signing key has now been imported and can be used to check the digital signature on the agent RPM file.

Finally, verify the signature on the RPM file

Tip: Instead of checking the signature on the RPM file manually, as described below, you can have a deployment script do it. See ["Use deployment scripts to add and protect computers" on page 1790](#) for details.

Use this command:

```
rpm -K Agent-PGPCore-<OS agent version>.rpm
```

Example:

```
rpm -K Agent-PGPCore-RedHat_EL7-11.0.0-950.x86_64.rpm
```

Make sure you run the above command on the `Agent-PGPCore-<...>.rpm` file. (Running it on `Agent-Core-<...>.rpm` does not work.) If you cannot find the `Agent-PGPCore-<...>.rpm` file in the agent ZIP, you'll need to use a newer ZIP, specifically:

- Deep Security Agent 11.0 Update 15 or a later update
or
- Deep Security Agent 12 Update 2 or later
or
- Deep Security Agent 20 or later

If the signature verification is successful, the following message appears:

```
Agent-PGPCore-RedHat_EL7-11.0.0-950.x86_64.rpm: rsa sha1 (md5) pgp  
md5 OK
```

Check the signature on a DEB file

First, install the `dpkg-sig` utility

Install [dpkg-sig](#) on the agent computer where you intend to check the signature, if it is not already installed. This utility includes the GPG command-line tool, which you need in order to import the signing key and check the digital signature.

Next, import the signing key

1. Look for the `3trend_public.asc` file in the root folder of the agent's ZIP file. The ASC file contains a GPG public signing key that you can use to verify the digital signature.
2. Optionally, verify the SHA-256 hash digest of the **ASC** file using any hashing utility. The hash is:

```
c59caa810a9dc9f4ecdf5dc44e3d1c8a6342932ca1c9573745ec9f1a82c118d7  
(For Agent version 20.0.0-2593 or earlier)
```

```
bd3b00763db11cee2a6b990428d506f11cf86c68354388fe9cc41fa7e6c9ddae  
(For Agent version 20.0.0-2971 or later)
```

```
7a7509c5458c762f6a341820a93e09f0f1b9dd3258608753e18d26575e9c730f  
(for Agent version 20.0.1-3180 or later)
```

3. On the agent computer where you intend to check the signature, import the ASC file to the GPG keyring. Use this command:

```
gpg --import 3trend_public.asc
```

The following message appears:

```
gpg: key E1051CBD: public key "Trend Micro (trend linux sign)  
<alloftrendetscodesign@trendmicro.com>" imported
```

```
gpg: Total number processed: 1
```

```
gpg: imported: 1 (RSA: 1)
```

4. (Optional) Display the Trend Micro key information. Use this command:

```
gpg --list-keys
```

A message similar to the following appears:

```
/home/user01/.gnupg/pubring.gpg  
-----  
pub 2048R/E1051CBD 2018-07-26 [expires: 2021-07-25]  
uid Trend Micro (trend linux sign)  
<alloftrendetscodesign@trendmicro.com>
```

```
sub 2048R/202C302E 2018-07-26 [expires: 2021-07-25]
```

Finally, verify the signature on the DEB file

Tip: Instead of verifying the signature on the DEB file manually, as described below, you can have a deployment script do it. See ["Use deployment scripts to add and protect computers" on page 1790](#) for details.

Enter the following command:

```
dpkg-sig --verify <agent_deb_file>
```

where `<agent_deb_file>` is the name and path of the agent DEB file. For example:

```
dpkg-sig --verify Agent-Core-Ubuntu_16.04-12.0.0-563.x86_64.deb
```

A processing message appears:

```
Processing Agent-Core-Ubuntu_16.04-12.0.0-563.x86_64.deb...
```

If the signature is verified successfully, the following message appears:

```
GOODSIG _gpgbuilder CF5EBBC17D8178A7776C1D365B09AD42E1051CBD  
1568153778
```

Deploy Deep Security Manager

Prepare a database

Database requirements

Before you install Deep Security Manager, you must install a database server for Deep Security Manager to use. This database server must meet the following requirements.

- ["Software requirements" on the next page](#)
- ["Hardware requirements" on page 436](#)
- ["Network requirements" on page 436](#)

- ["VMware requirements" on page 437](#)
- ["Scaling requirements" on page 437](#)

After reviewing the requirements, you are ready to [install the database server](#).

Software requirements

Deep Security supports these databases:

- PostgreSQL 14.x (only [Core](#), [Amazon RDS](#), or [Amazon Aurora](#) distributions)
- PostgreSQL 13.x (only [Core](#) or [Amazon RDS](#) distributions)
- PostgreSQL 12.x (only [Core](#) or [Amazon RDS](#) distributions)
- PostgreSQL 11.x (only [Core](#), [Amazon RDS](#), or [Amazon Aurora](#) distributions)
- Microsoft SQL Server 2022
- Microsoft SQL Server 2019
- Microsoft SQL Server 2017
- Microsoft SQL Server 2016
- Microsoft SQL Server 2014
- Microsoft SQL RDS
- Azure SQL Database (SaaS) ([multi-tenancy](#) is not supported)
- Oracle 19c is supported when deployed as software or when used with Amazon RDS
- Oracle 23c is supported when deployed as software

Note:

- PostgreSQL minor versions for the preceding releases are also supported.
- Microsoft SQL Server Express is only supported in very limited deployments. See ["Microsoft SQL Server Express considerations" on the next page](#).
- Microsoft SQL Server service packs for these versions are also supported.
- Microsoft SQL Server is only supported when database containment is set to NONE. For details, see [this Microsoft webpage on contained databases](#).
- Oracle Database Express (XE) is not supported.
- Oracle container database (CDB) configuration is not supported with Deep Security Manager multi-tenancy.

Microsoft SQL Server Express considerations

Some deployments might be able to use Microsoft SQL Server Express for the Deep Security Manager database. Important limitations are below. If you think your deployment cannot operate within these limitations, use another database, or [migrate to the Enterprise edition](#).

Warning: If you exceed the limits, you will experience a service outage and you will need to upgrade to a paid version of Microsoft SQL Server.

- **Express edition size limitations:** Microsoft SQL Server Express has a [10 GB maximum database size and other important limits](#). High load scenarios are not supported by Express. Symptoms can include database connection errors.
- **Express edition 'LocalDB' preset:** Express has a "LocalDB" preset. More configuration may be required to [accept remote connections](#).
- **Limited number of protected computers:** Do not use Microsoft SQL Server Express if your deployment has more than 50 protected computers. More computers' events will cause a larger database which Microsoft SQL Server Express cannot handle.
- **Lack of multi-node support:** Multi-node Deep Security Manager, required for larger deployments, is not supported by Express.
- **Security module limitations:** Only Deep Security Anti-Malware and Intrusion Prevention modules are supported with a Microsoft SQL Server Express database due to its limitations. If you require any other protection modules, use another supported database.

Hardware requirements

- The database CPU, memory, and disk space should conform to the recommendations in ["Database sizing" on page 403](#).
- The database should be installed on a dedicated server that is separate from the manager nodes.

Network requirements

- The database should be located on the same network as Deep Security Manager. The network should have a 1 GB LAN connection to ensure unhindered communication between the two. (WAN connections are not recommended.) The same applies to additional Deep Security Manager nodes. 2 ms latency or less is recommended for the connection from the manager to the database.

- Databases hosted in the cloud should not use multiple availability zones ("multi-AZ"), which can increase network latency.

VMware requirements

In a VMware environment, Deep Security Manager and its database should always run in the same ESXi host. To configure this:

1. In the vCenter Web Client, go to **Host and Clusters** and select the cluster.
2. Go to the **Manage** tab and click **VM/Host Rules > Add**.
3. Type a name for the rule.
4. Select **Enable rule**.
5. From **Type** select **Keep Virtual Machines Together**.
6. Click **Add** and select the manager and database VMs.

Scaling requirements

- You should use database load balancing, mirroring, and high availability (HA) mechanisms for scalability and service uptime. Consult your database vendor's documentation for setup details.
- If you decide to replicate the database, you should use database mirroring over database replication. Database replication technologies sometimes add columns to the database tables during replication. This changes the Deep Security database schema and can result in critical failures. Deep Security works with any failover protection technology that does not change its schema.

Install a database server

After reviewing the [database requirements](#), you are ready to install a database server. Refer to your database provider's documentation for instructions.

Tip: For a quick and easy setup, use PostgreSQL. It's free, and can be downloaded from this link: [PostgreSQL software download page](#).

After installing the database server, you are ready to [configure it](#).

Configure the database

After [installing the database](#), you are ready to configure it for Deep Security Manager.

First, configure a database instance, a database user, and a few other vendor-specific settings. See one of the following sections:

Configure PostgreSQL

Basic configuration

1. Connect to the PostgreSQL database server using a client program such as psql or pgAdmin.
2. Create an empty database instance and a database user with the appropriate permissions:

```
CREATE DATABASE "<database-name>";
```

```
CREATE ROLE "<dsm-username>" WITH PASSWORD '<password>' LOGIN;
```

```
GRANT ALL ON DATABASE "<database-name>" TO "<dsm-username>";
```

```
GRANT CONNECT ON DATABASE "<database-name>" TO "<dsm-username>";
```

This user will be used by Deep Security Manager to connect to the database instance.

Multi-tenancy configuration

If Deep Security Manager will have multiple tenants:

- Keep the main database name short. It will be easier to read your tenants' database names. (For example, if the main database is "dsm", the first tenant's database name will be "dsm_1", the second tenant's database name will be "dsm_2", and so on.)
- Also grant the right to create new databases and roles for tenants:

```
ALTER ROLE <dsm-username> CREATEDB CREATEROLE;
```

Optional PostgreSQL tuning

See ["Maintain PostgreSQL" on page 1523](#).

Configure Microsoft SQL Server

Basic configuration

1. Connect to Microsoft SQL Server by opening Microsoft SQL Server Management Studio (SSMS).
2. Create an empty database instance. This database instance will be used by Deep Security Manager.
3. Create a database account with **db_owner** rights. This account will be used by Deep Security Manager to connect to the database.
4. Enable the TCP/IP protocol for the database instance (see [https://docs.microsoft.com/en-us/previous-versions/bb909712\(v=vs.120\)?redirectedfrom=MSDN](https://docs.microsoft.com/en-us/previous-versions/bb909712(v=vs.120)?redirectedfrom=MSDN)).
5. Configure connection timeouts. Go **SQL management studio > SQL Server properties > Connections > Remote query timeout** and select **0 (No Timeout)**. This setting prevents database connection timeouts that can occur when you upgrade if each database schema migration operation takes a long time to complete.

Multi-tenancy configuration

If Deep Security Manager will have multiple tenants:

- Keep the main database name short. It will be easier to read your tenants' database names. (For example, if the main database is "dsm", the first tenant's database name will be "dsm_1", the second tenant's database name will be "dsm_2", and so on.)
- Also grant **dbcreator** rights to the database account used by the Deep Security Manager.

Configure Oracle Database

Basic configuration

1. Connect to Oracle Database using a client program such as SQL*Plus or SQL Developer.
 2. Start the "Oracle Listener" service. Verify that it accepts TCP connections.
 3. Create an empty database instance. This database instance will be used by Deep Security Manager.
-

4. Create a database account that will be used by Deep Security Manager to connect to the database. When creating the account, follow these guidelines:
 - Assign the **CONNECT** and **RESOURCE** roles and **UNLIMITED TABLESPACE**, **CREATE SEQUENCE**, **CREATE TABLE** and **CREATE TRIGGER** permissions.
 - Don't use special characters in Deep Security Manager's database user name. Although Oracle allows special characters when configuring the database user object if they are surrounded by quotes, Deep Security does not support special characters for the database user.

Oracle RAC configuration

If you're using Oracle RAC, disable the Firewall module or customize the Firewall settings according to the instructions in ["Firewall settings with Oracle RAC" on page 959](#).

Multi-tenancy configuration

If Deep Security Manager will have multiple tenants:

- Keep the main database name short. It will be easier to read your tenants' database names. (For example, if the main database is "MAINDB", the first tenant's database name will be "MAINDB_1", the second tenant's database name will be "MAINDB_2", and so on.)
- Also grant **CREATE USER**, **DROP USER**, **ALTER USER**, **GRANT ANY PRIVILEGE** and **GRANT ANY ROLE** to the Deep Security Manager's database user.
- Don't use the Oracle container database (CDB) configuration. It is **not** supported with Deep Security Manager multi-tenancy.

Next, perform these additional configurations:

1. Synchronize both time and time zone. Use the same time source on both the database and Deep Security Manager servers.
2. Allow network connections between Deep Security Manager and the database server. See ["Port numbers, URLs, and IP addresses" on page 410](#).
3. (Optional) Configure encryption. See ["Encrypt communication between the Deep Security Manager and the database" on page 1582](#).

After preparing the database, you can [install Deep Security Manager](#).

Run a readiness check

You can have the manager's installer run a readiness check to make sure your environment is ready for the Deep Security Manager installation. Nothing will be installed but the installer will check your installation environment to make sure it complies with [system requirements](#). It will then generate a report which you can use to fix any issues before actually installing Deep Security Manager. For example, you may need to free disk space, allocate more vRAM, or install a new OS. If you're not ready, you can cancel out of the installer and return when ready.

To run a readiness check

Step through the manager's graphical, interactive installer until you reach the page where you are offered the option to run the check. For details, see ["Install Deep Security Manager" on the next page](#).

To run a silent readiness check

Run the manager's silent installer with the `-t` option to indicate you want the installer to run in readiness check mode. For details, see ["Install Deep Security Manager silently" on page 447](#)

- Windows example:

```
Manager-Windows-<Version>.x64.exe -q -console -  
Dinstall4j.language=<ISO code> -varfile <PropertiesFile> -t
```

- Linux example:

```
Manager-Linux-<Version>.x64.sh [-q] [-console] -t [-  
Dinstall4j.language=<ISO code>] [-varfile <PropertiesFile>]
```

Note: On Linux, the readiness check might detect less RAM than the computer actually has. To verify the computer's actual total RAM, log in with a superuser account and enter: `grep MemTotal /proc/meminfo`

Install Deep Security Manager

Topics:

- ["Before you begin" below](#)
- ["Install the manager" on the next page](#)
- ["Test the installation \(log in to the manager\)" on page 446](#)
- ["Replace the self-signed certificate" on page 446](#)

Tip: You can find the supported deployment models for Deep Security Manager in section 3.3 of the [Deep Security Best Practice Guide \(PDF\)](#). Please note that **auto-scaling of manager nodes is not supported**.

Before you begin

Make sure you have completed these pre-installation tasks:

1. **Check system requirements for the manager:** See ["System requirements" on page 329](#).
2. **Prepare a database:** See ["Database requirements" on page 434](#), ["Install a database server" on page 437](#), and ["Configure the database" on page 437](#).
3. **Open ports:** Make sure you allow inbound and outbound communication to and from the manager on the appropriate port numbers. See ["Deep Security port numbers" on page 411](#).
4. **Allow URLs:** If you are planning on restricting the URLs to or from the manager server, make sure you allow the URLs described in ["Deep Security URLs" on page 416](#).
5. **Synchronize clocks:** Synchronize the OS clock of the manager's server with the clock of the database. Both computers should use the same NTP service.
6. **Configure DNS:** Configure DNS with the appropriate records so that the manager, agents, appliances, and relays can perform DNS lookup queries. Alternatively, use IP addresses, or add entries to the manager's hosts file. The server's DNS name cannot start with a number, such as 0000-dsm.example.com. If it does, the install log shows:
`java.io.IOException: DNSName components must begin with a letter`
7. **Download the manager software:** It's available at <https://help.deepsecurity.trendmicro.com/software.html>.
8. **Check the digital signature on the manager's installer file:** See ["Check the signature on installer files \(EXE, MSI, RPM or DEB files\)" on page 429](#).
9. **Run the readiness check:** See ["Run a readiness check" on the previous page](#).

Install the manager

After completing the tasks in ["Before you begin" on the previous page](#), you are ready to install the manager. You can use either:

- Graphical, interactive installer (follow the steps below)
- Silent installer (see ["Install Deep Security Manager silently" on page 447](#))

To run the graphical, interactive installer:

1. If you're installing on Linux, make sure X Windows System is installed so you can see the GUI.
2. Run the installer as root, superuser, or (on Windows) Administrator.
3. For details about how to fill out specific sections of the installer, read the sections below.

Choosing between a fresh install or an upgrade

If the installer detects an existing installation of the manager, you are prompted to select a fresh install or an upgrade.

- **Fresh install (can use existing or new database):** This option installs Deep Security software and initializes the database.
- **Upgrade:** This option installs new Deep Security software, but keeps existing computer details, policies, intrusion prevention rules, firewall rules, and so on. The database schema is updated, if required. Data is migrated to new formats, if required.

Warning: If you select **Fresh install (can use existing or new database)**, the installer will delete all data from any previous installation.

Configuring the database connection details

1. On the **Database** screen, select either **Microsoft SQL Server**, **Oracle Database**, or **PostgreSQL**, whichever you have configured in ["Configure the database" on page 437](#).
 2. In the **Host name** field, enter the database host name.
-

3. In the **Database name** field, enter the name of the empty database you created for use with Deep Security.
4. If you selected **Microsoft SQL Server**, then the manager's connection settings vary by authentication type:
 - SQL Server authentication: Enter the **User name** and **Password** of the SQL user.
 - Active Directory authentication: Enter the **User name**(no domain) and **Password** of an Active Directory user, and then click **Advanced** and enter the **Domain** separately. Active Directory authentication is also known as Kerberos or Windows domain authentication.

Note: See also "[SQL Server domain authentication problems](#)" on page 1929.

Note: With Microsoft SQL Server, Windows workgroup authentication is not supported.

5. If you selected **Oracle Database** or **PostgreSQL**, enter the user name and password of a database user who has permissions to the empty database you created for use with Deep Security.

Configuring a master key

On the **Master Key** screen, configure a master key. This key will be used to encrypt the passwords in the manager's database, `dsm.properties` file, and `configuration.properties` file. Choose one of the following options:

- **Configure later.** With this option, no master key is generated. Instead, the installer uses a hard-coded seed to encrypt the passwords mentioned above. Encrypted passwords are prefixed with `1`, for example, `database.Oracle.password=1***`. If you decide later that you'd like to use a master key instead of a hard-coded seed, you can use the `dsm_c -action masterkey` command to switch. See "[Command-line basics](#)" on page 1731 for details.
- **Use Amazon Web Services (AWS) Key Management Service (KMS).** This is the recommended method to provision a key because it does not rely on local files. With this option, the installer communicates with AWS KMS to obtain a 256-bit [symmetric customer master key \(CMK\)](#), which is then used to encrypt the

passwords mentioned above. [If you don't yet have a CMK in AWS KMS, follow these AWS instructions to create one](#). Specify the CMK's ARN in the **Amazon Resource Name (ARN)** field in the manager's installer. [To find the ARN, follow these AWS instructions](#). Encrypted passwords are prefixed with `DMK`, for example, `database.Oracle.password=DMK***`.

- **Use a local environment variable (automatically created)**. With this option, the installer generates a master key and uses it to encrypt the passwords mentioned above. Encrypted passwords are prefixed with `DMK`. The installer encrypts the master key with the secret that you specify in the **Secret** field, and then places the encrypted key in a local environment variable with a 'name' of 'LOCAL_KEY_SECRET'. The secret must include:
 - a capital letter
 - a lower cased letter
 - a number
 - a special character
 - between 8-64 characters

Warning: The secret must not be deleted, as it's required when Deep Security Manager initiates and when installing [additional manager nodes](#).

Note: The LOCAL_KEY_SECRET value is a salt (a unique piece of additional data provided to the key generation process) for the purpose of generating an actual master key to encrypt the database. Without the key, someone who steals the database can't decrypt it, and without the salt, the key itself can't be recalculated. This client-managed portion of the secret is offered as an option for you to customize the key generation process with additional data of your own, that you manage. But with or without the salt, the actual key is not stored in clear text. In addition, this string is stored in a file with root read-only permissions.

Choosing whether to install a co-located relay

Deep Security requires at least one relay. Relays distribute [security updates](#) to protected computers. For more information on relays, see ["Deploy additional relays" on page 1415](#).

When you run the Deep Security Manager installer, it searches its local directory for a full ZIP package of the agent installer. (Relays are agents whose relay feature is enabled.) If the ZIP is not found, then the manager's installer will try to download it from the Trend Micro Download Center on the Internet.

- If an agent installer is found in either location, the manager's installer will offer to install the newest relay.

Tip:

Trend Micro recommends that you install a local relay to:

- Provide a relay that is local to the manager
- Ensure that at least one relay is always available, even when you decommission old computers with relays

Warning: When the manager's installer adds an agent to its server, **it only enables the relay feature. It does not apply any default security settings.** To protect the server, in Deep Security Manager, [apply a security policy](#) to its agent.

- If no agent installer is found, you can download and install an agent or relay later.

Test the installation (log in to the manager)

The "Trend Micro Deep Security Manager" service starts automatically when you finish its installer. To log into Deep Security Manager's GUI, open a web browser and go to:

```
https://[host_name]:[port]/
```

where `[host_name]` is the IP address or domain name of the server where you installed Deep Security Manager, and `[port]` is the Manager Port you specified during installation.

Example:

```
https://example.dsm.com:4119/
```

Replace the self-signed certificate

When installing Deep Security for the first time, the installer creates a self-signed server certificate that Deep Security Manager uses to identify itself during secure connections with

agents, appliances, relays, and your web browser. It is valid for 824 days. However, because it is not signed by a trusted Certificate Authority (CA), your web browser will display warnings. To eliminate these warnings and improve security, consider replacing Deep Security's server certificate with one signed by a trusted CA. For details, see ["Replace the Deep Security Manager TLS certificate" on page 1570](#).

Install Deep Security Manager silently

Topics:

- ["Before you begin" below](#)
- ["Run a silent install on Windows" below](#)
- ["Run a silent install on Linux" on the next page](#)
- ["Silent install parameters" on the next page](#)
- ["Sample installation output" on page 449](#)
- ["Deep Security settings in the properties file" on page 451](#)
- [" Sample properties file" on page 460](#)

Before you begin

Make sure you have completed all pre-installation tasks in ["Install Deep Security Manager" on page 442](#).

Run a silent install on Windows

To initiate a silent install on Windows, open a command prompt in the same directory as the install package and run:

```
Manager-Windows-<Version>.x64.exe -q -console -Dinstall4j.language=<ISO code> -varfile <PropertiesFile>
```

For details on the parameters and variables in the above command, see ["Silent install parameters" on the next page](#).

Run a silent install on Linux

Note: Before executing this command, grant execution permission to the installation package.

To initiate a silent install on Linux, use the command line to go to the same directory as the install package and run:

```
Manager-Linux-<Version>.x64.sh -q -console -Dinstall4j.language=<ISO code>
-varfile <PropertiesFile>
```

For details on the parameters and variables in the above command, see ["Silent install parameters" below](#).

Silent install parameters

`-q` forces the installer to execute in unattended (silent) mode.

`-console` forces messages to appear in the console (stdout).

`-Dinstall4j.language=<ISO code>` lets you override the default installation language (English) if other languages are available. Specify a language using standard ISO language identifiers:

- Japanese: `ja`
- Simplified Chinese: `zh_CN`

`-varfile <PropertiesFile>`, where `<PropertiesFile>` is the full path to standard Java properties file with entries for the various settings you can apply during a Deep Security Manager install. Each property is identified by its equivalent GUI screen and setting in the Windows Deep Security Manager installation. For example, the Deep Security Manager address on the "Address and Ports" screen is specified as:

```
AddressAndPortsScreen.ManagerAddress=
```

Most of the properties in this file have acceptable defaults and may be omitted.

For a complete description of available settings, see ["Deep Security settings in the properties file" on page 451](#).

`-t` runs an installer readiness check rather than a regular install.

Sample installation output

The following is a sample output from a successful install, followed by an example output from a failed install (invalid license). The [Error] tag in the trace indicates a failure.

Successful install

```
Stopping Trend Micro Deep Security Manager Service...
Checking for previous versions of Trend Micro Deep Security Manager...
Upgrade Verification Screen settings accepted...
The installation directory has been set to C:\Program Files\Trend
Micro\Deep Security Manager.
Database Screen settings accepted...
License Screen settings accepted...
Address And Ports Screen settings accepted...
Credentials Screen settings accepted...
Security Update Screen settings accepted...
Software Update Screen settings accepted...
Smart Protection Network Screen settings accepted...
All settings accepted, ready to execute...
Extracting files ...
Setting Up...
Connecting to the Database...
Creating the Database Schema...
Creating MasterAdmin Account...
Recording Settings...
Creating Temporary Directory...
Installing Reports...
Installing Modules and Plug-ins...
Creating Help System...
Validating and Applying Activation Codes...
Configure Localizable Settings...
Setting Default Password Policy...
Creating Scheduled Tasks...
Creating Asset Importance Entries...
Creating Auditor Role...
Optimizing...
Importing Software Packages...
Configuring Relay For Install...
Importing Performance Profiles...
Recording Installation...
Clearing Sessions...
Creating Properties File...
Creating Shortcut...
Configuring SSL...
Configuring Service...
Configuring Java Security...
```

```
Configuring Java Logging...
Cleaning Up...
Starting Deep Security Manager...
Finishing installation ...
```

Failed install

This example shows the output generated when the properties file contains an invalid license string:

```
Stopping Trend Micro Deep Security Manager Service...
Detecting previous versions of Trend Micro Deep Security Manager...
Upgrade Verification Screen settings accepted...
Database Screen settings accepted...
Database Options Screen settings accepted...
[ERROR] The license code you have entered is invalid.
[ERROR] License Screen settings rejected...
Rolling back changes...
```

Deep Security settings in the properties file

The format of each entry in the settings property file is:

```
<Screen Name>.<Property Name>=<Property Value>
```

The settings properties file has required and optional values.

Note: If you enter an invalid value for optional properties, the installer will use the default value instead.

Required Settings

LicenseScreen

Property	Possible Values	Default Value
LicenseScreen.License.-1	<activation code for all modules>	<none>

OR

Property	Possible Values	Default Value
LicenseScreen.License.0	<activation code for Anti-Malware>	<none>
LicenseScreen.License.1	<activation code for Firewall/DPI>	<none>
LicenseScreen.License.2	<activation code for Integrity Monitoring>	<none>

Property	Possible Values	Default Value
LicenseScreen.License.3	<activation code for Log Inspection>	<none>

CredentialsScreen

Property	Possible Values	Default Value
CredentialsScreen.Administrator.Username	<username for the master administrator>	<none>
CredentialsScreen.Administrator.Password	<password for the master administrator>	<none>

Optional Settings

LanguageScreen

Property	Possible Values	Default Value	Notes
sys.languageId	en_US ja	en_US	<ul style="list-style-type: none"> "en_US" indicates English. "ja" indicates Japanese.

UpgradeVerificationScreen

This screen determines what happens if an existing installation is detected.

Note: This setting is not referenced unless an existing installation is detected.

Property	Possible Values	Default Value
UpgradeVerificationScreen.Overwrite	<ul style="list-style-type: none"> True False 	False

A True value results in a fresh install with all data in the existing database being discarded. A False value provides the option to repair the existing installation.

Warning: If you set this value to True, it will overwrite any existing data in the database. It will do this without any further prompts.

OldDataMigrationScreen

This screen defines the number of days of data to keep. When this setting is 0, all historical data will be kept, but this may increase the amount of time the upgrade will take. During the data

migration, the silent install will show the percentage of records migrated at 10% intervals.

Note: This setting is not referenced unless an existing installation is detected and it requires a data migration to upgrade the database schema.

Property	Possible Values	Default Value
OldDataMigrationScreen.HistoricalDays	<integer>	0

DatabaseScreen

This screen defines the database type and optionally the parameters needed to access certain database types.

Note: In the interactive install, you can click **Advanced** to define the instance name and domain of a Microsoft SQL server. This appears in a dialog. Because the unattended install does not support dialogs, these arguments are included in the DatabaseScreen settings below.

Property	Possible Values	Default Value	Notes
DatabaseScreen.DatabaseType	<ul style="list-style-type: none"> Microsoft SQL Server Oracle PostgreSQL 	Microsoft SQL Server	None
DatabaseScreen.Hostname	<ul style="list-style-type: none"> <database hostname or IP address> Current host name 	Current host name	None You can specify the port in this entry using the format <hostname>:<port>. Example: <code>example:123</code>
DatabaseScreen.DatabaseName	<string>	dsm	
DatabaseScreen.Transport	<ul style="list-style-type: none"> Named Pipes TCP 	Named Pipes	Required for SQL Server only

Property	Possible Values	Default Value	Notes
DatabaseScreen.Username	<database username>	<none>	Username used by the manager to authenticate to the database server. Must match an existing database account. Note that the Deep Security Manager database permissions will correspond to this user's permissions. For example, if you choose a database account with read-only privileges, the Deep Security Manager will not be able to write to the database. Mandatory for Microsoft SQL Server and Oracle.
DatabaseScreen.Password	<database password>	<none>	Password used by the manager to authenticate to the database server. Mandatory for Microsoft SQL Server and Oracle.
DatabaseScreen.SQLServer.Instance	<string>	<none>	Used only with Microsoft SQL Server, which supports multiple instances on a single server or processor. Only one instance can be the default instance and any others are named instances. If the Deep Security Manager database instance is not the default, enter the name of the instance here. The value must match an existing instance or be left blank to indicate the default instance.
DatabaseScreen.SQLServer.Domain	<string>	<none>	Used only with Microsoft SQL Server. This is the Windows domain used when authenticating to

Property	Possible Values	Default Value	Notes
			the SQL Server. The DatabaseScreen.UserName and DatabaseScreen.Password described above are only valid within the appropriate domain.
DatabaseScreen.SQLServer.UseDefaultCollation	<ul style="list-style-type: none"> • True • False 	False	Used only with Microsoft SQL Server. Collation determines how strings are sorted and compared. If the value is "False", Deep Security will use Latin1_General_CS_AS for collation on text-type columns. If the value is "True", Deep Security will use the collation method specified by your SQL Server database. For additional information on collation, refer to your SQL Server documentation.

AddressAndPortsScreen

This screen defines the hostname, URL, or IP address of this computer and defines port numbers for the manager. In the interactive installer, this screen also supports connecting a new manager node to an existing database, but this option is not supported in the unattended install.

Property	Possible Values	Default Value	Notes
AddressAndPortsScreen.ManagerAddress	<manager hostname, URL or IP address>	<current host name>	None
AddressAndPortsScreen.ManagerPort	<port number>	4119	See "Port numbers, URLs, and IP addresses" on page 410.
AddressAndPortsScreen.HeartbeatPort	<port number>	4120	See "Port numbers, URLs, and IP addresses" on page 410.
AddressAndPortsScreen.NewNode	<ul style="list-style-type: none"> • True 	False	True indicates that the current install is a new node. If the

Property	Possible Values	Default Value	Notes
	<ul style="list-style-type: none"> False 		installer finds existing data in the database, it will add this installation as a new node. (Multi-node setup is always a silent install.) Note: The "New Node" installation information about the existing database to be provided via the DatabaseScreen properties.

CredentialsScreen

Property	Possible Values	Default Value	Notes
CredentialsScreen.UseStrongPasswords	<ul style="list-style-type: none"> True False 	False	<code>True</code> causes Deep Security Manager to enforce strong passwords.

MasterKeyConfigurationScreen

Property	Possible Values	Default Value	Notes
MasterKeyConfigurationScreen.KeyConfigType	<ul style="list-style-type: none"> Do not configure Local Key KMS 	Do not configure	If configured, the installer will use KMS or the local key secret to generate a custom master key. If not configured, a hard-coded seed is used instead. See also masterkey . Instead, you must run masterkey commands after the installer.
MasterKeyConfigurationScreen.ARN	<AWS ARN>	<none>	The Amazon Resource Name (ARN) of the KMS key. Only used if <code>MasterKeyConfigurationScreen.KeyConfigType</code> is KMS.
MasterKeyConfigurationScreen.LocalKey	<string>	<none>	The value that you want to use when the installer configures the local environment variable <code>LOCAL_KEY_SECRET</code> . Only used if <code>MasterKeyConfigurationScreen.KeyConfigType</code> is Local Key.

SecurityUpdateScreen

Property	Possible Values	Default Value	Notes
SecurityUpdateScreen.UpdateComponents	<ul style="list-style-type: none"> • True • False 	True	True will tell the Deep Security Manager to create a scheduled task to automatically check for security updates. The scheduled task will run when installation is complete.
SecurityUpdateScreen.Proxy	<ul style="list-style-type: none"> • True • False 	False	True will cause Deep Security Manager to use a proxy to connect to the Internet to download security updates from Trend Micro.
SecurityUpdateScreen.ProxyType	<ul style="list-style-type: none"> • HTTP • SOCKS4 • SOCKS5 	<none>	The protocol used by the proxy.
SecurityUpdateScreen.ProxyAddress	<valid IPv4 or IPv6 address or hostname>	<none>	None
SecurityUpdateScreen.ProxyPort	<proxy port>	<none>	See " Port numbers, URLs, and IP addresses " on page 410.
SecurityUpdateScreen.ProxyAuthentication	<ul style="list-style-type: none"> • True • False 	False	True indicates that the proxy requires authentication credentials.
SecurityUpdateScreen.ProxyUsername	<string>	<none>	None
SecurityUpdateScreen.ProxyPassword	<string>	<none>	None

SoftwareUpdateScreen

Property	Possible Values	Default Value	Notes
SoftwareUpdateScreen.UpdateSoftware	<ul style="list-style-type: none"> • True • False 	True	True will tell Deep Security Manager to create a scheduled task to automatically check for software updates. The scheduled task will run when installation is complete.

Property	Possible Values	Default Value	Notes
SoftwareUpdateScreen.Proxy	<ul style="list-style-type: none"> • True • False 	False	True will cause Deep Security Manager to use a proxy to connect to the Internet to download software updates from Trend Micro.
SoftwareUpdateScreen.ProxyType	<ul style="list-style-type: none"> • HTTP • SOCKS4 • SOCKS5 	<none>	The protocol used by the proxy.
SoftwareUpdateScreen.ProxyAddress	<valid IPv4 or IPv6 address or hostname>	<none>	None.
SoftwareUpdateScreen.ProxyPort	<integer>	<none>	See "Port numbers, URLs, and IP addresses" on page 410.
SoftwareUpdateScreen.ProxyAuthentication	<ul style="list-style-type: none"> • True • False 	False	True indicates that the proxy requires authentication credentials.
SoftwareUpdateScreen.ProxyUsername	<string>	<none>	None
SoftwareUpdateScreen.ProxyPassword	<string>	<none>	None

SmartProtectionNetworkScreen

This screen defines whether you want to enable Trend Micro Smart Feedback and optionally your industry.

Property	Possible Values	Default Value	Notes
SmartProtectionNetworkScreen.EnableFeedback	<ul style="list-style-type: none"> • True • False 	False	True enables Trend Micro Smart Feedback.
SmartProtectionNetworkScreen.IndustryType	<ul style="list-style-type: none"> • Not specified • Banking • Communications and media • Education 	<none>	If a value is not entered, it has the same result as Not

Property	Possible Values	Default Value	Notes
	<ul style="list-style-type: none"> • Energy • Fast-moving consumer goods (FMCG) • Financial • Food and beverage • Government • Healthcare • Insurance • Manufacturing • Materials • Media • Oil and gas • Real estate • Retail • Technology • Telecommunications • Transportation • Utilities • Other 		<p>specified.</p>

RelayScreen

This screen defines whether you want to install the Deep Security Relay on the same computer as Deep Security Manager.

Property	Possible Values	Default Value	Notes
RelayScreen.Install	<ul style="list-style-type: none"> • True • False 	False	<p><code>True</code> installs the Deep Security Relay on the Deep Security Manager computer.</p> <p><code>False</code> does not install the Deep Security Relay on the Deep Security Manager (silent install), or shows a</p>

Property	Possible Values	Default Value	Notes
			screen asking you whether you want to install the relay (regular install).

Sample properties file

This is an example of the content of a typical properties file:

```
AddressAndPortsScreen.ManagerAddress=10.xxx.xxx.xxx
AddressAndPortsScreen.NewNode=True
UpgradeVerificationScreen.Overwrite=False
LicenseScreen.License.-1=XY-ABCD-ABCDE-ABCDE-ABCDE-ABCDE-ABCDE
DatabaseScreen.DatabaseType=Microsoft SQL Server
DatabaseScreen.Hostname=10.xxx.xxx.xxx
DatabaseScreen.Transport=TCP
DatabaseScreen.DatabaseName=XE
DatabaseScreen.Username=DSM
DatabaseScreen.Password=xxxxxxx
AddressAndPortsScreen.ManagerPort=4119
AddressAndPortsScreen.HeartbeatPort=4120
CredentialsScreen.Administrator.Username=masteradmin
CredentialsScreen.Administrator.Password=xxxxxxx
CredentialsScreen.UseStrongPasswords=False
SecurityUpdateScreen.UpdateComponents=True
SecurityUpdateScreen.Proxy=False
SecurityUpdateScreen.ProxyType=
SecurityUpdateScreen.ProxyAddress=
SecurityUpdateScreen.ProxyPort=
SecurityUpdateScreen.ProxyAuthentication=False
SecurityUpdateScreen.ProxyUsername=
SecurityUpdateScreen.ProxyPassword=
SoftwareUpdateScreen.UpdateSoftware=True
SoftwareUpdateScreen.Proxy=False
SoftwareUpdateScreen.ProxyType=
SoftwareUpdateScreen.ProxyAddress=
SoftwareUpdateScreen.ProxyPort=
SoftwareUpdateScreen.ProxyAuthentication=False
SoftwareUpdateScreen.ProxyUsername=
SoftwareUpdateScreen.ProxyPassword=
```

```
RelayScreen.Install=True  
SmartProtectionNetworkScreen.EnableFeedback=False
```

Add activation codes

You must enter one or more activation codes into the manager if you didn't supply them during the installation.

Note: An activation code is also known as a license.

To enter your activation code or codes:

1. Log in to Deep Security Manager.
2. At the top, click **Administration**.
3. On the left, click **Licenses**.
4. In the main pane, click **Enter New Activation Code**.
5. Enter the activation code or codes you obtained from your sales representative.
6. Click **Next** and close the wizard when you have finished.

Set up multi-tenancy

Set up a multi-tenant environment

The multi-tenancy feature in Deep Security lets you create separate management environments within a single Deep Security Manager. It allows tenants to each have their own settings and policies and to monitor their own events. This can be useful if you want to create separate staging and production environments or if you need to create separate environments for different business units in your organization. You can also use multi-tenancy to provision Deep Security to customers in a service model.

Once you enable multi-tenancy, you (as the "primary tenant") retain all of the capabilities of a regular installation of Deep Security Manager. However, the tenants you subsequently create can have their access to Deep Security functionality restricted to varying degrees, based on how you configure the system for them.

Note: FIPS mode is not supported in a multi-tenant environment, See ["FIPS 140 support" on page 1811](#).

In this topic:

- ["Multi-tenancy requirements" below](#)
- ["Enable multi-tenancy" on the next page](#)
- ["Create a tenant" on the next page](#)
- ["Scalability guidelines" on page 465](#)
- ["Multi-tenancy tips" on page 466](#)
- ["Managing tenants" on page 467](#)
- ["Set up a multi-tenant environment" on the previous page](#)
- ["Usage monitoring" on page 470](#)
- ["Configure database user accounts" on page 473](#)
- ["APIs" on page 481](#)
- ["Upgrade a multi-tenant environment" on page 482](#)
- ["Supporting tenants" on page 483](#)
- ["Multi-tenancy with Deep Security Virtual Appliance" on page 483](#)

Multi-tenancy requirements

You cannot set up multi-tenancy with:

- Deep Security Manager VM for Azure Marketplace
- Azure SQL Database
- Azure SQL or on-premise Always On availability groups

Multi-tenancy requires an activation code. Multi-tenancy also has additional database requirements. For details, see ["Database requirements" on page 434](#) and ["Configure database user accounts" on page 473](#).

To maximize scalability, we recommend that you use a multi-node Deep Security Manager (see ["Install Deep Security Manager on multiple nodes" on page 488](#)). All manager nodes process GUI, heartbeat, or job requests for any tenant. For background processing, each tenant is assigned a manager node that takes care of job queuing, maintenance, and other background tasks. Tasks are rebalanced across remaining nodes when manager nodes are added or taken offline.

When you enable multi-tenancy, your current installation of Deep Security Manager becomes the primary tenant (t0) and has special privileges, including the ability to create other tenants. Other tenants are restricted from using certain features and don't have permissions to see the UI

for those features in Deep Security Manager. For example, non-primary tenants cannot create other tenants. For details, see "[Set up a multi-tenant environment](#)" on page 461

Enable multi-tenancy

Note: Once you enable multi-tenancy, you cannot disable it or remove the primary tenant.

1. In the Deep Security Manager, go to **Administration > System Settings > Advanced**. In the Multi-Tenant Options area, click **Enable Multi-Tenancy**.
2. The Multi-Tenant Configuration wizard appears. Enter your multi-tenancy activation code and click **Next**.
3. Choose the license mode that you want to use:
 - **Inherit Licensing from Primary Tenant:** This option gives all tenants the same licenses that you (the primary tenant) have. This option is recommended if you are using multi-tenancy in a staging environment, or if you intend to set up tenancies for separate departments within your organization.
 - **Per Tenant Licensing:** With this configuration, you can use the Deep Security API to provide a license when you create a tenant, or the tenant can enter a license when they sign in to the Deep Security Manager for the first time.
4. Click **Next**.

When the wizard closes, you'll be able to see **Administration > System Settings > Tenants**, where you can configure multi-tenancy options. For information about the options on that page, click **Help** in the upper-right corner of Deep Security Manager.

Create a tenant

Tip: You can automate tenant creation and configuration using the Deep Security API. For examples, see the [Create and Manage Tenants](#) guide in the Deep Security Automation Center.

Once multi-tenant mode is enabled, tenants can be managed from **Administration > Tenants**.

For information about the database user account permissions that are required for adding tenants, see "[Configure database user accounts](#)" on page 473.

1. In the Deep Security Manager, go to **Administration > Tenants** and click **New**.
2. The New Tenant wizard appears. Enter a **Tenant Account Name**. The account name can be anything except "Primary", which is reserved for the primary tenant.

3. Enter the email address that is used to contact the tenant.
4. Select the **Locale**. The locale determines the language of the Deep Security Manager user interface for the tenant.
5. Select a **Time Zone**. Times for events are shown relative to this time zone, not the time zone on the system where the event happened.
6. If your Deep Security installation uses more than one database, select whether to let Deep Security automatically select a database server on which to store the new tenant account ("Automatic -- No Preference") or to use a particular server.

Database servers that are not accepting new tenants do not appear in the list.

7. Enter a user name for the first user of the new tenant account.
8. Select one of the three password options:
 - **No Email:** The tenant's first user's user name and password are defined here and no emails are sent.
 - **Email Confirmation Link:** You set the tenant's first user's password. However, the account is not active until the user clicks a link in the confirmation email. The email confirmation ensures that the email provided belongs to the user before they can access the account.
 - **Email Generated Password:** This allows you to generate a tenant without specifying the password.

Tip:

All three options are available via the API. The email confirmation option is suitable for developing public registration. A CAPTCHA is recommended to ensure that the tenant creator is a human not an automated bot.

9. Click **Next** to finish with the wizard and create the tenant.

Tenant creation can take up to four minutes due to the creation of the schema and the population of the initial data. This ensures each new tenant has the most up-to-date configuration and removes the burden of managing database templates, especially between multiple database servers.

Each tenant database has an overhead of around 100 MB of disk space (due to the initial rules, policies and events that populate the system).

Examples of messages sent to tenants

Email Confirmation Link: Account Confirmation Request

Welcome to Deep Security! To begin using your account, click the following confirmation URL. You can then access the console using your chosen password.

Account Name: ExampleCorp

User name: admin

Click the following URL to activate your account:

<https://managerIP:portnumber/SignIn.screen?confirmation=1A16EC7A-D84F-D451-05F6-706095B6F646&tenantAccount=ExampleCorp&username=admin>

Email Generated Password

First email : Account and Username Notification

Welcome to Deep Security! A new account has been created for you. Your password will be generated and provided in a separate email.

Account Name: ExampleCorp

Username: admin

You can access Deep Security using the following URL:

<https://managerIP:portnumber/SignIn.screen?tenantAccount=ExampleCorp&username=admin>

Second email: Password Notification

This is the automatically generated password for your Deep Security account. Your Account Name, Username, and a link to access Deep Security will follow in a separate email.

Password: z3IgRUQ0jaFi

Scalability guidelines

Deployments of 50-100 tenants or more should follow these guidelines to avoid scalability issues:

- Create a maximum of 2000 tenants for a set of Deep Security Manager nodes
- Create a maximum of 300 tenants on a single database server
- Use a separate database server for the primary tenant, with no other tenants
- Limit the number of agents per tenant to 3000
- Limit the number of total agents to 20000
- Use a maximum of 2 Deep Security Manager nodes
- Do not use any co-located relays

Multi-tenancy relies on using multiple databases (if you are using Microsoft SQL) or multiple users (if you are using Oracle). To scale further, you can connect Deep Security Manager to multiple database servers and automatically distribute the new tenants across the available set of database servers. See ["Configure database user accounts" on page 473](#).

Multi-tenancy tips

Reconnaissance IP list

In a multi-tenant environment, tenants may need to add the Deep Security Manager IP address to the "Ignore Reconnaissance IP" list found in **Policies > Common Objects > Lists > IP Lists**. This is to avoid getting a "Reconnaissance Detected: Network or Port Scan" warning.

Use multiple database servers

Multi-tenancy relies on using multiple databases (if you are using Microsoft SQL) or multiple users (if you are using Oracle). To scale further, you can connect Deep Security Manager to multiple database servers and automatically distribute the new tenants across the available set of database servers. See ["Configure database user accounts" on page 473](#).

Tenant pending deletion state

Tenants can be deleted, but the process is not immediate. Before it deletes records, Deep Security requires that all its tenant-related jobs are finished. The least frequent job runs every week, so tenants may remain in the "pending deletion" state for up to approximately 7 days.

Multi-tenant options under System Settings

Consider these options on **Administration > System Settings > Tenants**:

Allow Tenants to use the Relays in my "Default Relay Group" (for unassigned Relays): Gives tenants automatic access to relay-enabled agents set up in the primary tenant. This saves tenants the effort of setting up dedicated relay-enabled agents for security updates.

Allow Tenants to use the "Run Script" Scheduled task: Scripts present a potentially dangerous level of access to the system; however, the risk can be mitigated because scripts have to be installed on the Deep Security Manager using file-system access.

Managing tenants

Administration > Tenants displays the list of all tenants. A tenant can be in any of these **States**:

- **Created:** Created, but activation email has not been sent to the tenant user.
- **Confirmation Required:** Created, but the activation link in the confirmation email sent to the tenant user has not been clicked. (You can manually override this state.)
- **Active:** Fully online and managed.
- **Suspended:** No longer accepting sign-ins.
- **Pending Deletion:** Tenants can be deleted, but it is not immediate. The tenant may be in the "pending deletion" state for up to 7 days, until pending jobs finish.
- **Database Upgrade Failed:** For tenants that failed the upgrade path. The Database Upgrade button can be used to resolve this situation.

Tenant Properties

Double-click on a tenant to view the tenant's **Properties** window.

General

You can change the locale, time zone and state. Changes do not affect existing tenant users (only new ones, and parts of the UI that are not user-specific).

The **Database Name** indicates the name of the database used by this tenancy. You can access the tenant database's properties via the hyperlink.

Modules

The **Modules** tab provides options for protection module visibility. The selected visibility can be used to tune which modules are visible for which tenants. By default all unlicensed modules are hidden. You can change this by deselecting **Always Hide Unlicensed Modules**. Alternatively, selected modules can be shown on a per-tenant basis.

By default, if you use "per tenant" licensing, each tenant only sees their licensed modules.

If you select **Inherit License from Primary Tenant**, then all tenants can see all features that you (the primary tenant) are licensed for.

Note: If you select this option, then all of the primary tenant's unlicensed modules are hidden for other tenants, *even if you deselect their option **Always Hide Unlicensed Modules***.

If you are evaluating Deep Security in a test environment and want to see what a full multi-tenancy installation looks like, you can enable "Multi-Tenancy Demo Mode". When in Demo Mode, the manager populates its database with simulated tenants, computers, events, alerts, and other data. Initially, 7 days' worth of data is generated but new data is generated on an ongoing basis to keep the manager's dashboard, reports and events pages populated with data.

Warning: Do **not** use Demo Mode in a production environment. Demonstration data will be mixed with real data, which can make it difficult to determine if there are real attacks or malware.

Features

As an Administrator, you can enable or disable certain features for specific tenants. These available features may change over time.

If you enable **Extended Descriptions for Event Forwarding**, Deep Security includes the full description of events that are forwarded to Amazon SNS or a SIEM. Otherwise, descriptions are omitted. **SAML Identity Provider Integration**, **Amazon WorkSpaces Integration**, **Application** (Application Control), and [API Rate Limits](#) (in the Automation Center) are enabled by default.

Statistics

The Statistics tab shows information for the current tenant including database size, jobs processed, logins, security events and system events. The spark line show the last 24 hours at a glance.

Agent Activation

The Agent Activation tab displays a command that you can run to activate the agent on the computer. The command is relative to the agent install directory of this tenant's computers. Activation is required so that Deep Security Manager can securely connect with it, and the tenant can assign policies and perform other configuration procedures from the Deep Security Manager.

What does the tenant see?

When multi-tenancy is enabled, the sign-in page has an additional **Account Name** text field.

Tenants are required to enter their account name in addition to their user name and password. The account name allows tenants to have overlapping user names. For example, if multiple tenants synchronize with the same Active Directory server.

Note: When you (as the primary tenant) log in, leave the account name blank or use "Primary".

Some features in the Deep Security Manager UI are not available to tenant users. These areas are hidden for tenants:

- Manager Nodes Widget
- Multi-Tenant Widgets
- Administration > System Information
- Administration > Licenses (If Inherit option selected)
- Administration > Manager Nodes
- Administration > Tenants
- Administration > System Settings:
 - Tenant Tab
 - Security Tab > Sign In Message
 - Updates Tab > Setting for Allowing Tenants to use Relays from the Primary Tenant
 - Advanced Tab > Load Balancers
 - Advanced Tab > Pluggable Section
- Some of the help content not applicable to tenants
- Some reports not applicable to tenants
- Other features based on the multi-tenant options
- Some alert types are also be hidden from tenants:
 - Heartbeat Server Failed
 - Low Disk Space
 - Manager Offline
 - Manager Time Out Of Sync
 - Newer Version of Deep Security Manager available

- Number of Computers Exceeds Database Limit
- And when inherited licensing is enabled any of the license-related alerts

It is also important to note that tenants cannot see any of the multi-tenant features of the primary tenant or any data from any other tenant. In addition, certain APIs are restricted since they are only usable with primary tenant rights (such as creating other tenants).

For more information on what is and is not available to tenant users, see ["Multi-tenant settings" on page 484](#).

All tenants have the ability to use role-based access control (RBAC) with multiple user accounts to further sub-divide access. Additionally, they can use Active Directory integration for users to delegate the authentication to the domain. The Tenant Account Name is still required for any tenant authentications.

Agent-Initiated Activation

Agent-initiated activation is enabled by default for all tenants.

Note: Unlike agent-initiated activation for the primary tenant, a password and tenant ID are required to invoke the activation for other tenant users.

Tenants can see the arguments required for agent-initiated activation by going to **Administration > Updates > Software > Local**, selecting the agent software, and then clicking **Generate Deployment Scripts**. For example, the script for Agent-Initiated Activation on a Windows machine might look like this:

```
dsa_control -a dsm://<host or IP>:4120/ "tenantID:XXXXXXXX-XXXX-XXXX-XXXX-XXXXXXXXXXXX" "token:XXXXXXXX-XXXX-XXXX-XXXX-XXXXXXXXXXXX"
```

Tenant diagnostics

Tenants are not able to access manager diagnostic packages due to the sensitivity of the data contained within the packages. Tenants can still generate agent diagnostics by opening the computer editor, going to **Actions > Overview**, and then selecting **Agent Diagnostics**.

Usage monitoring

Deep Security Manager records data about tenant usage. To view it, go to the dashboard's **Tenant Protection Activity** widget, the Tenant **Properties** window's **Statistics** tab, and reports. This information can also be accessed through the legacy REST API's status monitoring, which

can be enabled or disabled by going to **Administration > System Settings > Advanced > Status Monitoring API**.

Use the legacy REST API's status monitoring to customize the type of tenant information that you would like to see, depending on your environment. For enterprises, this can be useful to determine the usage by each business unit. You can also use the information to monitor the usage of the overall Deep Security system and look for indicators of abnormal activity. For example, if a single tenant experiences a spike in security event activity, it might be under attack.

Multi-tenant Dashboard

When multi-tenancy is enabled, primary tenant users have access to the following additional Dashboard widgets for monitoring tenant activity:

- Tenant Database Usage
- Tenant Job Activity
- Tenant Protection Activity
- Tenant Security Event Activity
- Tenant Sign-In Activity
- Tenant System Event Activity
- Tenants

The same information is available on **Administration > Tenants** (some in optional columns) and on the **Statistics** tab of a tenant's **Properties** window.

This information provides the ability to monitor the usage of the overall system and look for indicators of abnormal activity. For example, if a single tenant experiences a spike in security event activity, they might be under attack.

Multi-tenant reports

To generate reports that contain the information you require, go to **Event & Reports > Generate Reports** and choose the report you'd like to generate from the drop-down menu. The following are reports for multi-tenant environments, and the information they include:

Security Module Usage Cumulative Report

- Tenant
- Hostname

- ID
- Anti-Malware hours
- Network hours
- System hours
- SAP hours
- Enterprise hours

Security Module Usage Report

- Tenant
- ID
- Hostname
- Display name
- Computer group
- Instance type
- Start date
- Start time
- Stop time
- Duration (seconds)
- Anti-malware
- Web Reputation
- Firewall
- Intrusion prevention
- Integrity monitoring
- Log Inspection
- Application Control
- SAP

Tenant Report

- Tenant name
- Database size

- Peak host count
- Protection hours
- Percentage of protected hours

Configure database user accounts

The majority of each tenant's data is stored in a separate database. This database can co-exist on the same database server as other tenants, or it can be isolated onto its own database server. In all cases, some data only exists in the primary database (the one installed with Deep Security Manager). When multiple database servers are available, tenants are created on the database with the least amount of load.

The segmentation of each tenant's data into a database provides additional benefits:

- **Data destruction:** Deleting a tenant removes all traces of that tenant's data (supported in the product).
- **Backup:** Each tenant's data can be subject to different backup policies. This can be useful for something like tenancy being used for staging and production where the staging environment requires less stringent backups (backups are the responsibility of the administrator setting up Deep Security Manager).
- **Balancing:** The potential for future re-balancing to maintain an even load on all database servers.

Configuring database user accounts

Note:

Microsoft SQL Server, Oracle, and PostgreSQL use different terms for database concepts described below.

Concept	SQL Server term	Oracle term	PostgreSQL term
Process where multiple tenants execute	Database Server	Database	Database Server
One tenant's set of data	Database	Tablespace/User	Database

The following section uses the Microsoft SQL Server terms for both SQL Server and Oracle.

SQL Server

Tip: Use a short name for the main database name to make it easier to read your tenants' database names. Deep Security derives tenants' database names from the main (primary tenant)'s SQL database name. For example, if the main database is named "dsm", then the first tenant's database is "dsm_1", the second tenant's database name is "dsm_2", and so on.

Multi-tenancy requires that Deep Security can create databases when you create new tenants, so its SQL Server database user requires the "dbcreator" role.

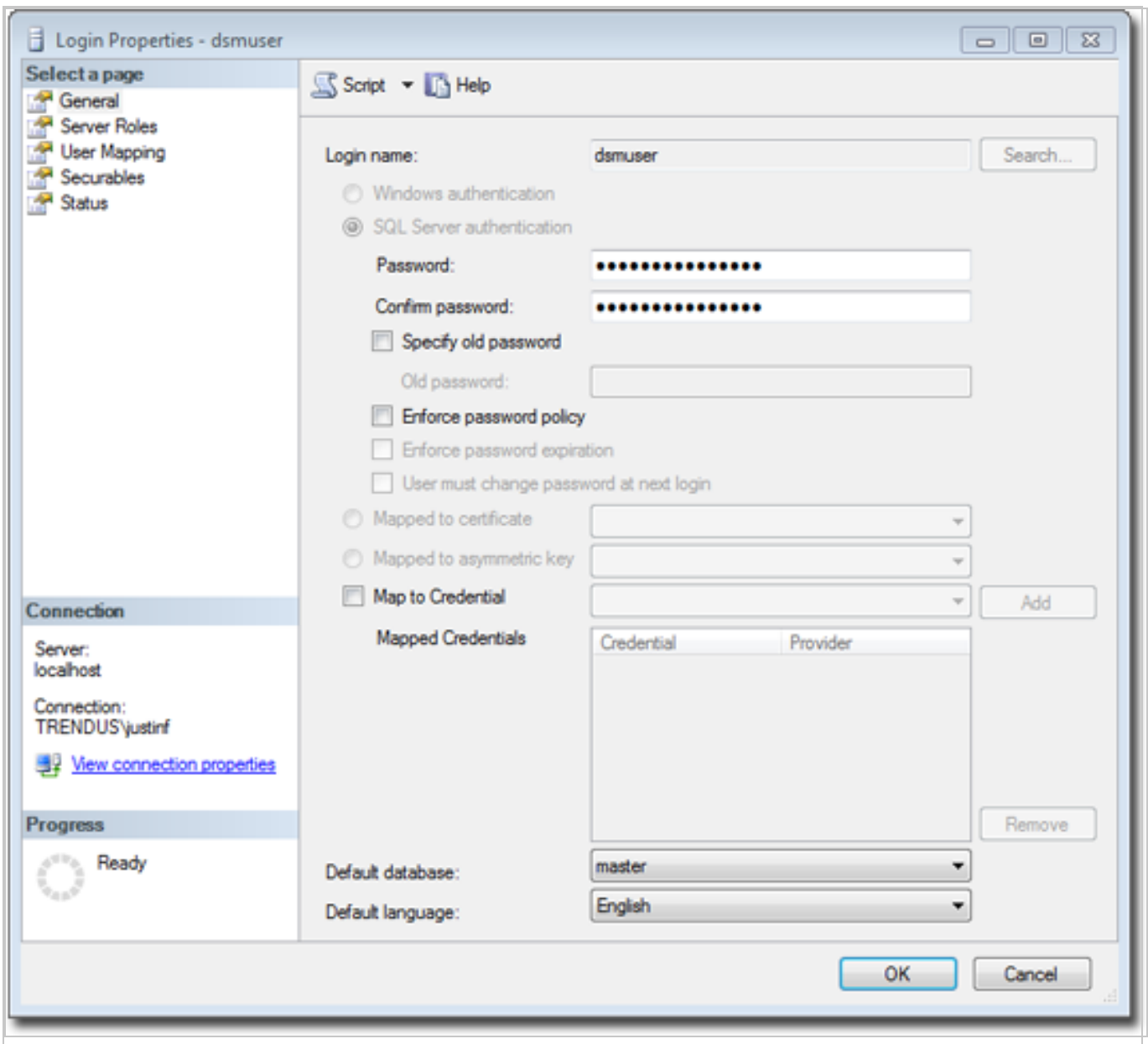

For the user role of the primary tenant, assign DB owner to the main database.

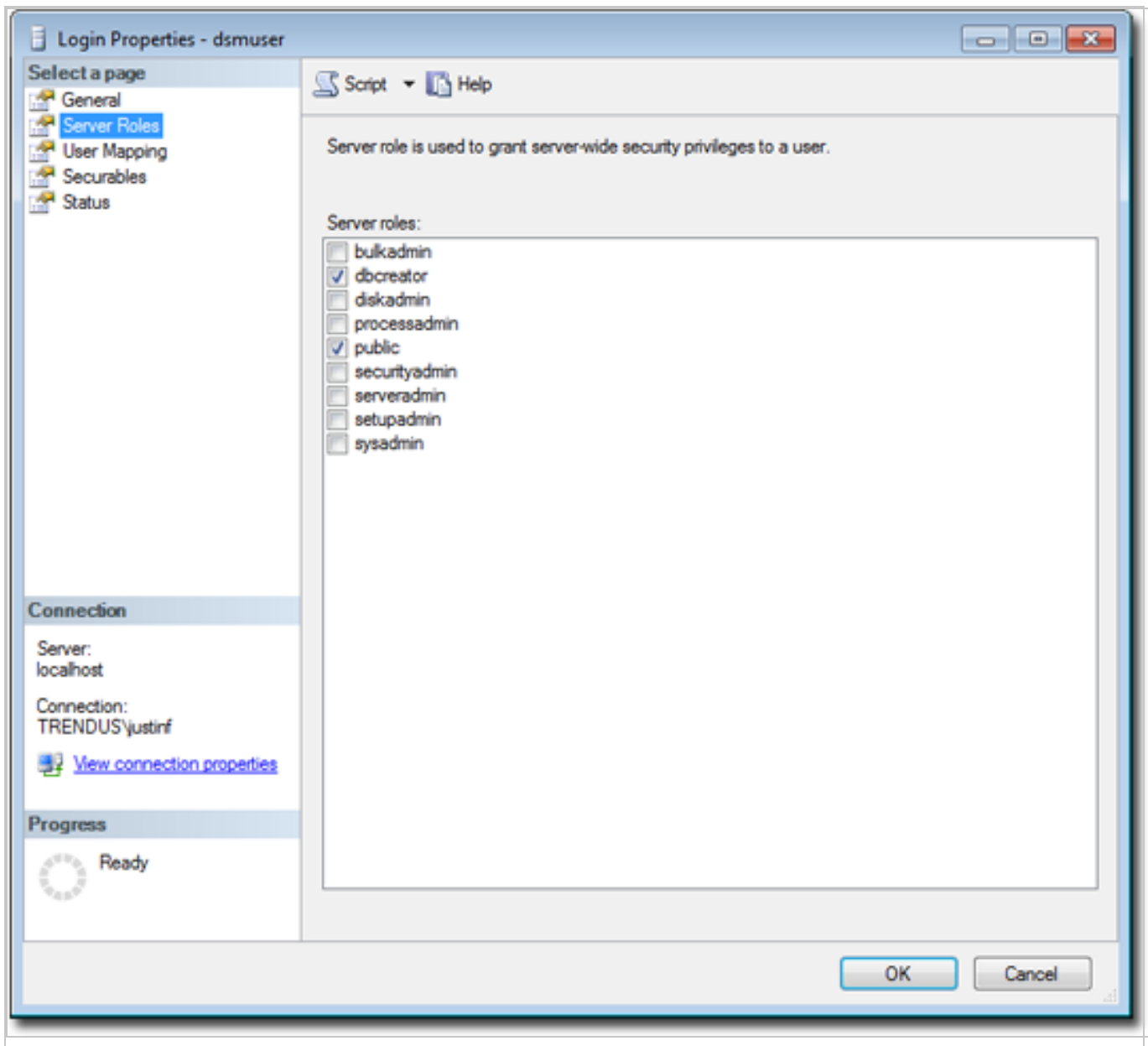

You can restrict the rights to include only the ability to modify the schema and access the data.

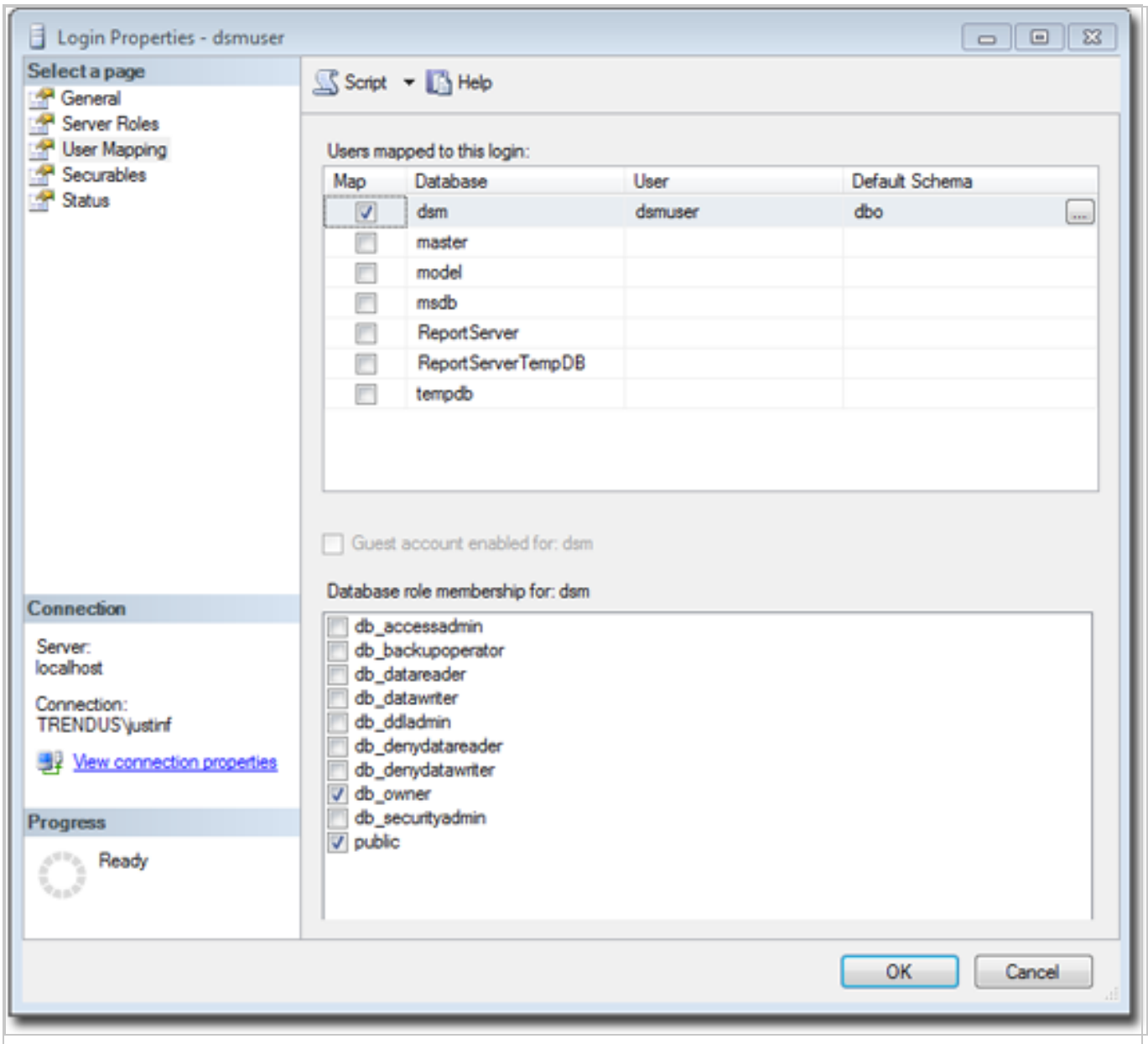

With the "dbcreator" role, databases that the account creates are automatically owned by the same user. For example, here are the user's properties after the first tenant has been created:

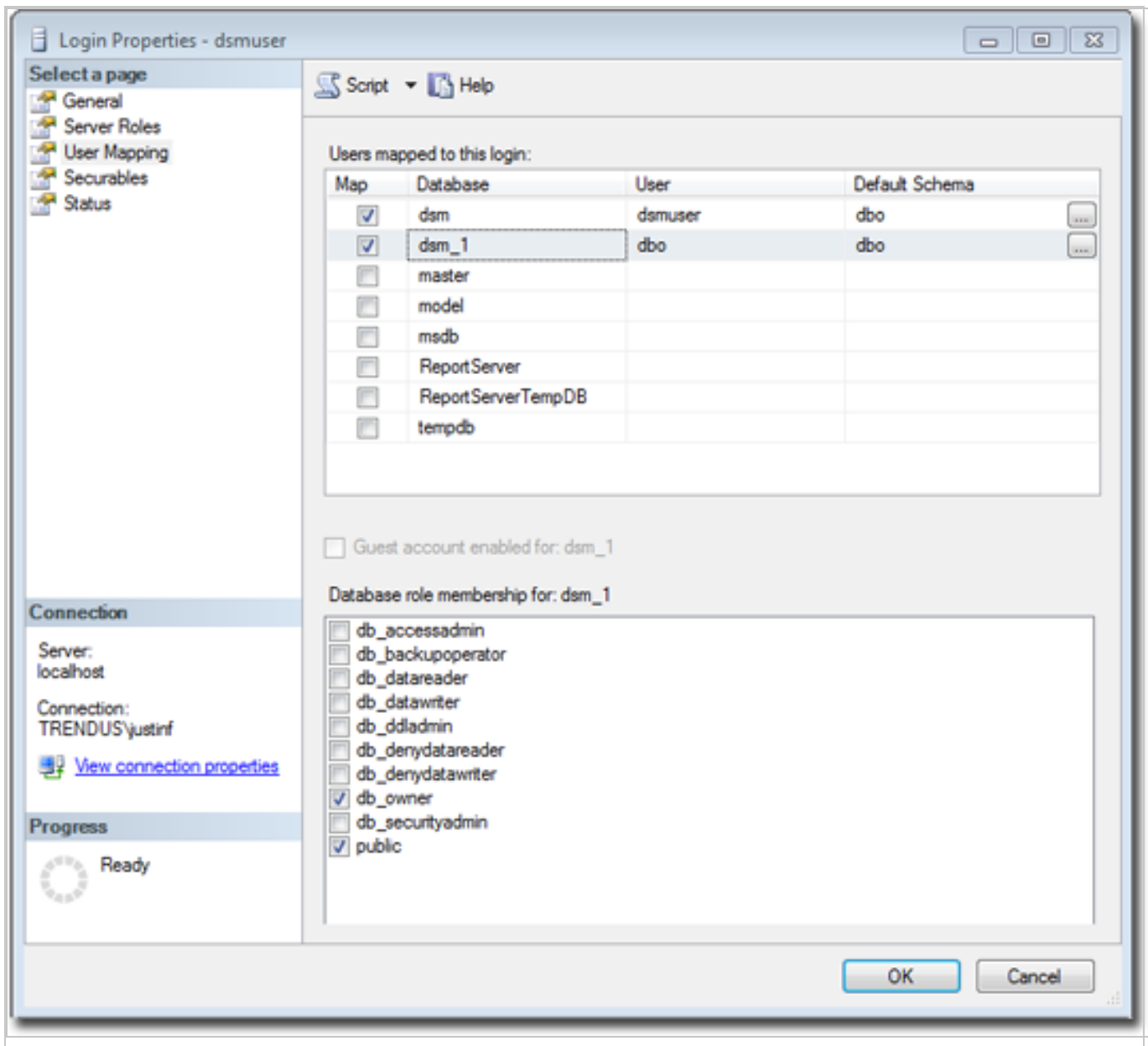

To create the first account on a secondary database server, only the "dbcreator" server role is required. No user mapping is required.

Oracle

Multi-tenancy in Oracle is similar to Microsoft SQL Server, but with a few important differences. Where SQL Server has a single user account per database server, Oracle uses one user account per tenant. The user that Deep Security was installed with maps to the primary tenant. That user can be granted permission to allocate additional users and tablespaces.

Note: Although Oracle allows special characters in database object names if they are surrounded by quotes, *Deep Security does not support special characters in database object names*. This page on Oracle's web site describes the allowed characters in non-quoted names: https://docs.oracle.com/cd/B28359_01/server.111/b28286/sql_elements008.htm#SQLRF00223#SQLRF00223

Tip: Use a short name for the main database name to make it easier to read your tenants' database names. Deep Security derives tenants' database names from the main (primary tenant)'s Oracle database name. For example, if the main database is named "MAINDB", then the first tenant's database is "MAINDB_1", the second tenant's database name is "MAINDB_2", and so on.

If multi-tenancy is enabled, you must assign these Oracle permissions:

Roles

Role	Admin Option	Default
CONNECT	N	Y
RESOURCE	N	Y

System Privileges

System Privilege	Admin Option
ALTER USER	N
CREATE SEQUENCE	N
CREATE TABLE	N
CREATE TRIGGER	N
CREATE USER	N
DROP USER	N
GRANT ANY PRIVILEGE	N
GRANT ANY ROLE	N
UNLIMITED TABLESPACE	N

Object Privileges

Object Privilege	Schema	Object	Grant Option
No items found			

Tenants are created as users with long random passwords and given these permissions:

Roles

Role	Admin Option	Default
CONNECT	N	Y
RESOURCE	N	Y

System Privileges

System Privilege	Admin Option
CREATE SEQUENCE	N
CREATE TABLE	N
CREATE TRIGGER	N
UNLIMITED TABLESPACE	N

Object Privileges

Object Privilege	Schema	Object	Grant Option
No items found			

For secondary Oracle servers, you must create the first user account (a bootstrap user account). This user has a mostly tablespace. The configuration is identical to the primary user account.

PostgreSQL

The user must have permissions to create new databases and roles:

```
ALTER ROLE [username] CREATEDB CREATEROLE;
```

On a secondary database server, the hostname, username, and password are required. The username must have privileges to create additional users (roles) and databases.

Tip: Use a short name for the main database name to make it easier to read your tenants' database names. Deep Security derives tenants' database names from the main (primary tenant)'s PostgreSQL database name. For example, if the main database is named "dsm", then

the first tenant's database is "dsm_1", the second tenant's database name is "dsm_2", and so on.

Configuring multiple database servers

By default, all tenants are created on the same database server that Deep Security Manager was installed with. In order to provide additional scalability, Deep Security Manager supports adding additional database servers (sometimes referred to as a secondary database). When you add a tenant, you have the option to let Deep Security automatically select a database server on which to store the new tenant account or you can specify a particular server.

To configure more databases, go to **Administration > System Settings > Tenants**. In the Database Servers section, click **View Database Servers**, and then click **New** .

For Microsoft SQL Server, the secondary database server requires a hostname, user name, and password (named instance and domain). The Deep Security Manager's database user must have these permissions:

- Create databases
- Delete databases
- Define schema

This account is used not only to create the database but to authenticate to the databases that are created.

For Oracle, multi-tenant deployments use a different model. The new database definition defines a user that is bound to a tablespace. That user is used to "bootstrap" the creation of additional users on Oracle.

Removing or changing secondary databases

You can delete database servers (other than the primary database) if there are no tenants on the server.

If the hostname, user name, password or any details change for a secondary server, you can change these values in the Deep Security Manager console. To change values for the primary database, you must shut down all nodes of the Deep Security Manager and edit the dsm.properties file with the new details.

APIs

Deep Security Manager includes a number of APIs for:

1. Enabling Multi-Tenancy
2. Managing Tenants
3. Accessing Monitoring Data
4. Accessing Chargeback (Protection Activity) Data
5. Managing Secondary Database Servers

In addition, the legacy SOAP API includes an authenticate method that accepts the Tenant Account Name as a third parameter.

For more information on the APIs, see ["Use the Deep Security API to automate tasks" on page 1764](#).

Upgrade a multi-tenant environment

1. Back up all databases:
 - With Microsoft SQL and PostgreSQL, there's one main database and an additional database for each tenant.
 - With Oracle, all tenant information is in one manager database, but an additional user is created for each tenant. Each user has its own tables.
2. Upgrade the manager.
3. The installer does the following:
 - shuts down other [manager nodes](#), if they exist, and then starts to upgrade
 - updates the database schema
 - migrates data into the new structures for the primary tenant (t0)
 - migrates data for other tenants (five in each batch)
4. After the manager has been fully upgraded including all tenants, upgrade the next manager node, if it exists. See ["Upgrade a multi-tenant environment" above](#) for details.

Notes:

- If the t0 migration fails, the installer can't recover. It does not continue. You must restore the database from backup, and then try again.
- If any non-primary tenant's migration fails, the installer continues, but each tenant's state on **Administration > Tenants** is set to **Database Upgrade Required (offline)**. You can either restore from backup and run the installer again, or you can retry migration for that specific tenant.
- To retry a tenant's migration, use the tenant's interface. If forcing a retry does not work, please contact your support provider

Supporting tenants

Especially if you are an MSSP that is the first tier support provider to your tenants, sometimes a primary tenant might need to log in to another tenant's user interface.

To do this, go to **Administration > Tenants**. Right-click the tenant's name, and then select **Authenticate As**. (The option may not be available if the tenant has disabled access.) This creates a temporary user account with the "Full Access" role inside that tenant, and immediately logs you into that account. Temporary account names are "support_" followed by their username inside the primary tenant.

For example, if your primary tenant username is "jdoe", and you create a temporary account inside tenant "T1", then you would be immediately logged into "T1" as "support_jdoe".

Temporary support accounts are deleted when either they log out or their session times out. Tenants can see system events about the temporary support account's creation, log in, log out, and deletion.

Users in the primary tenant can access more diagnostic tools and information:

1. **Administration > System Information** has more information about tenant memory usage and the state of threads.
2. `server#.log` log files (such as `server0.log`) on each manager node's disks have the name of the tenant, and the user if applicable, associated with each event.

In some cases, you may need to perform an action or change a tenant's setting that is not available in the GUI. This usually comes at the request of Trend Micro support. In the [command line](#), add the argument:

```
-tenantname <tenant-name>
```

to apply setting changes or actions to that tenant. If the argument is omitted, the command applies to the primary tenant.

Multi-tenancy with Deep Security Virtual Appliance

If Deep Security is being deployed in a VMware environment, you can configure the vCenter and its connector in the primary tenant and the vCloud connector in tenants. If this is configured properly, the primary tenant sees the ESXi servers, Deep Security Virtual Appliances, and other infrastructure while tenants only see the agentlessly protected VMs that belong to them in the vCloud environment.

To enable this type of environment, go to **Administration > System Settings > Agents** and select **Allow Appliance protection of vCloud VMs**.

For more information on vCloud integration, see ["Install the agent on VMware vCloud" on page 535](#).

Multi-tenant settings

The **Tenants** tab appears only if you have enabled multi-tenant mode.

- **Multi-Tenant License Mode:** The multi-tenant license mode can be changed after multi-tenant is setup, however it is important to note that switching from inherited to per-tenant will cause existing tenants to no longer have any licensed module.
- **Allow Tenants to use the "Run Script" Scheduled Task:** Scripts present a potentially dangerous level of access to the system, however the risk can be mitigated because scripts have to be installed on the Manager using file-system access.
- **Allow Tenants to run "Computer Discovery" (directly and as a Scheduled Task):** Determines if discovery is allowed. This may not be desirable in service provider environments where network discovery has been prohibited.
- **Allow Tenants to run "Port Scan" (directly and as a Scheduled Task):** Determines if port scans can be executed. This may not be desirable in service provider environments where network scan has been prohibited.
- **Allow Tenants to add VMware vCenters:** Determines for each tenant if vCenter connectivity should be allowed. If the deployment occurs via an unsecured or public network such as the Internet, usually this option should be disabled.
- **Allow Tenants to add with Cloud Accounts:** Determines if tenants can setup cloud sync. This is generally applicable to any deployment.
- **Allow Tenants to synchronize with LDAP Directories:** Determines if tenants can setup both User and Computer sync with Directories (LDAP or Active Directory for Computers, Active Directory only for users). If deployment occurs via an unsecured or public network such as the Internet, usually this option should be disabled.
- **Allow Tenants to configure independent Event Forwarding SIEM settings:** Displays the SIEM settings on the Event Forwarding tab.
- **Allow Tenants to configure SNS settings:** Displays the SNS settings on the Event Forwarding tab.
- **Allow Tenants to configure SNMP settings:** Allow tenants to forward System Events to a remote computer (via SNMP). If this option is not selected, all tenants use the settings

located on the Event Forwarding tab for all event types and syslogs are relayed via the Deep Security Manager.

- **Show the "Forgot Password?" option:** Displays a link on the sign in screen which Users can access to reset their password. SMTP settings must be properly configured on the **Administration > System Settings > SMTP** tab for this option to work.
- **Show the "Remember Account Name and Username" option:** Deep Security will remember the User's Account Name and Username and populate these fields when the sign in screen loads.
- **Allow Tenants to control access from the Primary Tenant:** By default, the primary tenant can sign in to a tenant's account by using the **Sign In As Tenant** option on the **Administration > Tenants** page. When the **Allow Tenants to control access from Primary Tenant** option is selected, tenants are given the option (under **Administration > System Settings > Advanced** in their) to allow or prevent access by primary tenant to their Deep Security environment. (When this option is enabled, the default setting in the tenant's environment is to prevent access by the primary tenant.)

Note: Whenever the primary tenant accesses a tenant's account, the access is recorded in the tenant's System Events.

- **Allow Tenants to use Primary Tenant's Suspicious Object List and Sandbox Analysis settings:** Enables the primary tenant to share their Deep Discovery Analyzer and Trend Micro Apex Central settings with tenants. For details, see ["Detect emerging threats using Threat Intelligence" on page 833](#).
- **Allow Tenants to use the Relays in my "Default Relay Group":** gives tenants automatic access to relays setup in the primary tenant. This saves tenants from having to setup dedicated Relays for Security Updates.

Note: Tenants can reject the usage of "shared" relays by going to the **Updates** tab on the **Administration > System Settings** and deselecting **Use the Primary Tenant Relay Group as my Default Relay Group (for unassigned Relays)**. Then they must set up relays for themselves.

Note: When relays are shared, the primary tenant must keep the relays up-to-date. To ensure this, you can create **Download Security Update** scheduled tasks for all relays at a regular intervals.

- **Enable the automatic download of Security Updates on new Tenants:** As soon as you create a new tenant account, it will check for and download the latest available security updates.
- **Lock and hide the following options (all Tenants will use the Primary Tenant's configurations):**
 - **Data Privacy options on the "Agents" Tab:** Allows the primary tenant to configure data privacy settings. (This setting only applies to "Allow Packet Data Capture on Encrypted Traffic (SSL)" in on the **Administration > System Settings > Agents** tab.)
 - **All options on the "SMTP" Tab:** Locks all settings on the **SMTP** tab.
 - **All options on the "Storage" Tab:** Locks all settings on the **Storage** tab.

Database servers

By default, all tenants will be created on the same database server that Deep Security Manager was installed with. In order to provide additional scalability, Deep Security Manager supports adding additional database servers. For details, see ["Set up a multi-tenant environment" on page 461](#).

New tenant template

Using a tenant template, you can conveniently create a customized "out-of-the-box" experience for new tenants. This feature can be useful in service provider (MSSP) environments where some of the examples are not applicable, or special examples need to be created.

Note: Existing tenants are not affected when you create a new template.

1. Log in as the primary tenant.
2. Create a new tenant.
3. Log out, then log in as the new tenant.
4. Customize the example policies (such as adding, removing, or modifying policies) and/or the security update version (such as applying newer versions).

Tenants should use the example policies as a starting point, and then customize to match their unique needs.

Note: Security update packages must have a valid digital signature. If you specify an invalid security update, new tenant creation will fail. See also ["About upgrades" on page 1607](#).

5. Log out, then log in again as the primary tenant.
6. Run the tenant template wizard.
7. Select the tenant to create a snapshot.

Templates **include:**

- Latest Security Update rules (Updates that have been applied to the template when created. This includes intrusion prevention rules provided by Trend Micro, change monitoring rules, security log monitoring rules)
- Policy Firewall rules
- IP list
- MAC list
- Directory listing
- File list
- File extension list
- Port list
- Contexts
- Schedule
- Firewall Stateful Configuration
- Malware scan settings

Templates **exclude:**

- Custom Intrusion Prevention rules
- Custom Application Types
- Custom Integrity Monitoring rules
- Custom Log Inspection rules
- Custom Log Inspection Decoders
- Dashboard
- Alert settings
- System settings

- Scheduled tasks
- Event-based tasks
- Users
- Roles
- Contact information

Protection usage monitoring

Deep Security collects information about protected computers. This information is visible on the dashboard in the tenants widget and the Tenant Protection Activity widget. The information is also provided in the Tenant report and is available via the legacy REST API.

Note: In the most basic case, the monitoring can help determine the percentage usage of Deep Security Manager by hours of protection through the report or the API. Commonly called viewback or chargeback this information can be used in a variety of ways. In more advanced cases, this can be used for custom billing based on characteristics like tenant computer operating systems.

Use these options to determine which additional tenant computer details are recorded.

Set up multiple nodes

Install Deep Security Manager on multiple nodes

Instead of running Deep Security Manager on *one* server, you can install Deep Security Manager on *multiple* servers ("nodes") and connect them to one shared database. This provides better:

- Reliability
- Availability
- Scalability
- Performance

You can log in to any node. Each node can do all types of tasks. No node is more important than any of the others. A node failure does not cause service downtime, and does not result in data loss. Deep Security Manager processes many concurrent activities in a distributed pool that all online nodes execute. All activity that does not happen due to user input is packaged as a job,

and runs on any available manager (with some exceptions for "local" jobs that are executed on each node, like cache clearing).

Each node must run the same Deep Security Manager software version. When you upgrade, the first manager you upgrade will temporarily take over all duties and shut down the other nodes. On **Administration > Manager Nodes**, other nodes' status will be "Offline" with an indication that an upgrade is required. Once upgraded, nodes will automatically return online and begin processing again.

Set up a load balancer

If you are deploying multiple server nodes of Deep Security Manager for a large scale deployment, a load balancer can help distribute connections with agents and appliances. Load balancers with virtual IPs can also provide a single inbound port number such as TCP 443, instead of the multiple port numbers that Deep Security normally requires.

Balance load based upon TCP connections; do not use SSL termination. This ensures that an entire connection occurs with the same manager node. The next connection may be distributed to a different node.

For more Deep Security Manager deployment recommendations, see the ["Deep Security Best Practice Guide" on page 1962](#).

Configure the load balancer in Deep Security

By default, a multi-node manager gives the address of all nodes to all agents and virtual appliances. The agents and virtual appliances randomly select a node from the list when they try to connect. If they cannot, then they try another node on the list, continuing this process until either a connection succeeds, or no nodes can be reached. If they can't reach any node, then they wait until the next heartbeat to try again.

Each time a node is added or removed, an updated list is sent to all agents and virtual appliances. Until then, connections to old nodes may fail, and the new node will be unused. This causes slow communications and increased network traffic. To avoid this, instead [configure agents and virtual appliances to connect via the load balancer's address](#).

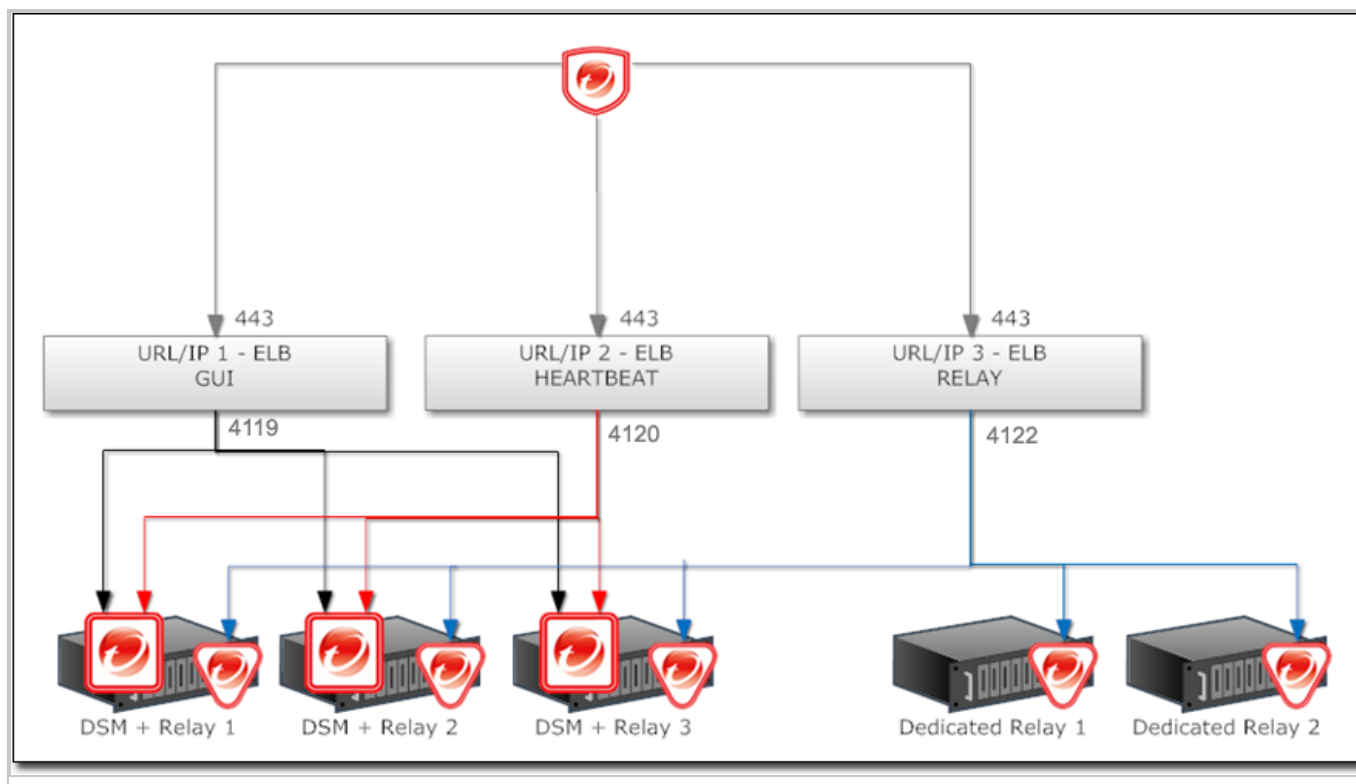

Add a node

1. ["Set up a load balancer" on the previous page.](#)
2. After you have installed Deep Security Manager on one server node, [run the installer again on another server](#). Make sure you follow the guidelines below.
 - Install the same version of the manager on all nodes.
 - Never run more than one instance of the installer at the same time. Doing so can lead to unpredictable results including corruption of the database.
 - Connect all nodes to the same database.
 - Make sure all nodes use the same master key (if configured).
 - Have the master key always available so that all nodes can decrypt and read the encrypted configuration properties and personal data when required. For more information, see [masterkey](#).
 - If the installer shows a **Master Key** page with the following text: **Type the local secret used to access the master key. All nodes that belong to the same Deep Security Manager must be configured with the same local secret.** On this page, enter the secret that you specified when you set up the first node. For details, see ["Install the manager" on page 443](#).

- Set the system clock of each manager node to use the same time zone. The database must also use the same time zone. If the time zone is different, this causes Manager Time Out of Sync errors.

Remove a node

Before you remove or replace a server, you should remove it from the pool of Deep Security Manager nodes.

1. Halt the service or uninstall Deep Security Manager on the node that you want to remove.

Its status must change to "Offline".

2. Log into Deep Security Manager on another node.
3. Go to **Administration > Manager Nodes**.

4. Double-click the node that you want to remove.

The node's Properties window should appear.

5. In the **Options** area, click **Decommission**.

Upgrade a node

Follow the instructions in "[Upgrade the manager in a multi-node deployment](#)" on page 1621 for details on upgrading manager nodes.

Viewing node statuses

To display all Deep Security Manager nodes along with their status, combined activity, and jobs being processed, go to **Administration > System Information**. From the drop-down menu, select which graph you want to view.

Network Map with Activity Graph

The **Network Map with Activity Graph** in the **System Activity** area displays a map of all installed manager nodes and their current status as well their relative activity over the last hour. The nodes can be in the following states:

- **Online**
- **Offline**
- **Offline (Upgrade Required)**

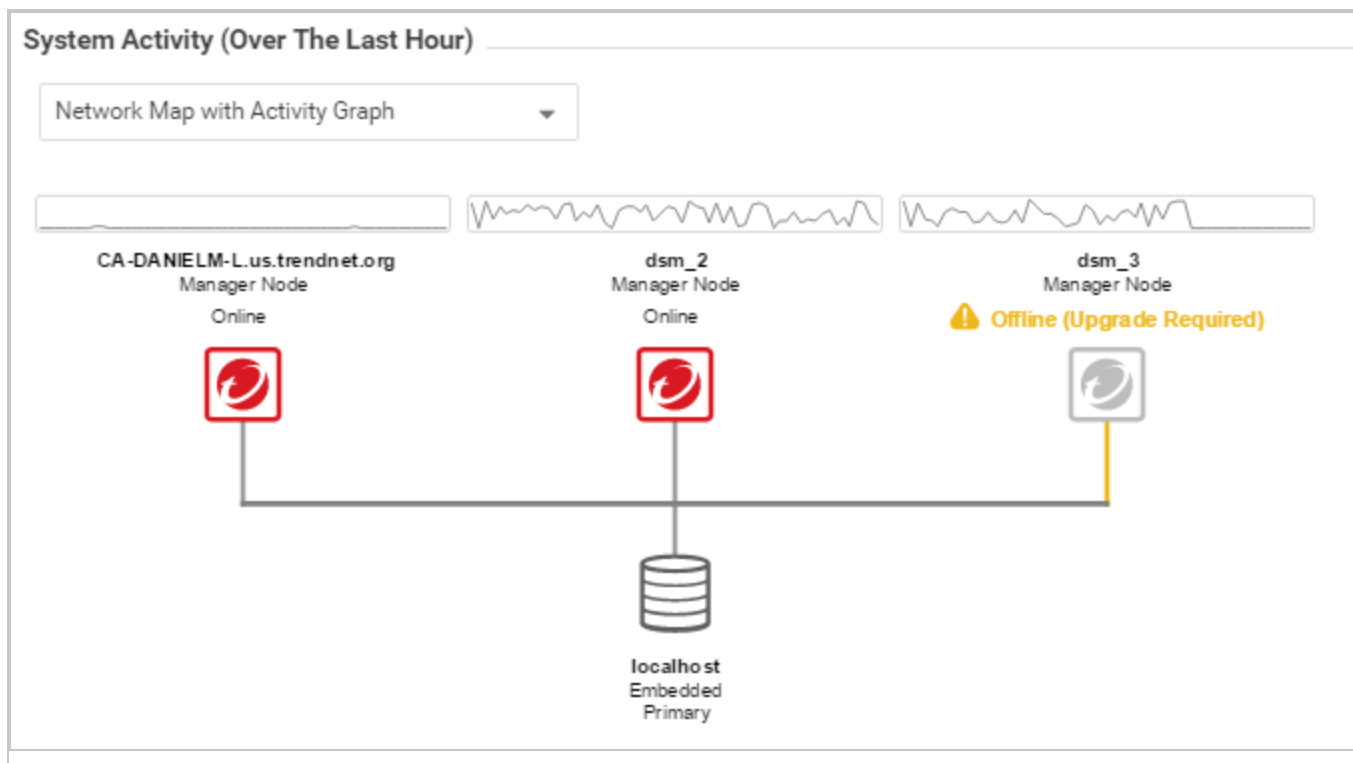

Note: All Deep Security Manager nodes periodically check the health of all other nodes. If any manager node loses network connectivity for more than 3 minutes, it is considered offline. The remaining nodes assume its tasks.

Jobs by Node

This chart displays the number of jobs carried out over the last hour by each node.

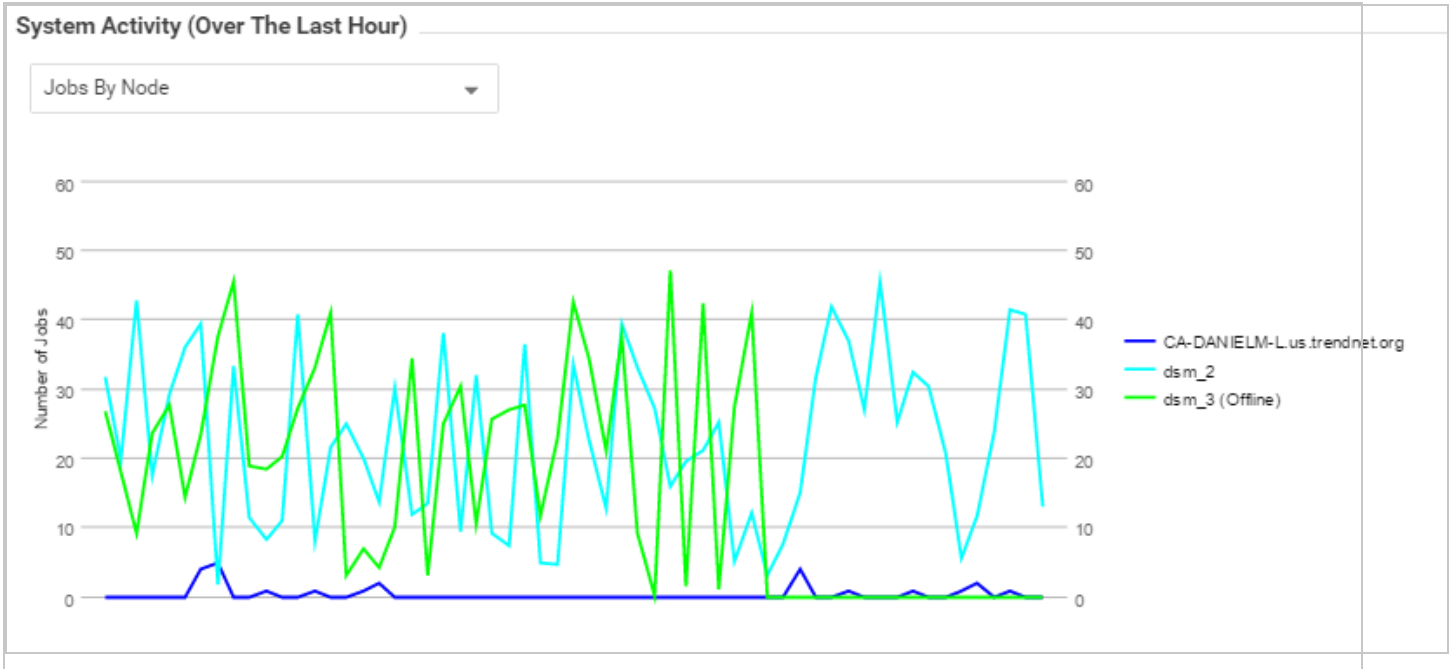

Jobs by Type

This chart displays the jobs carried out over the last hour by type.

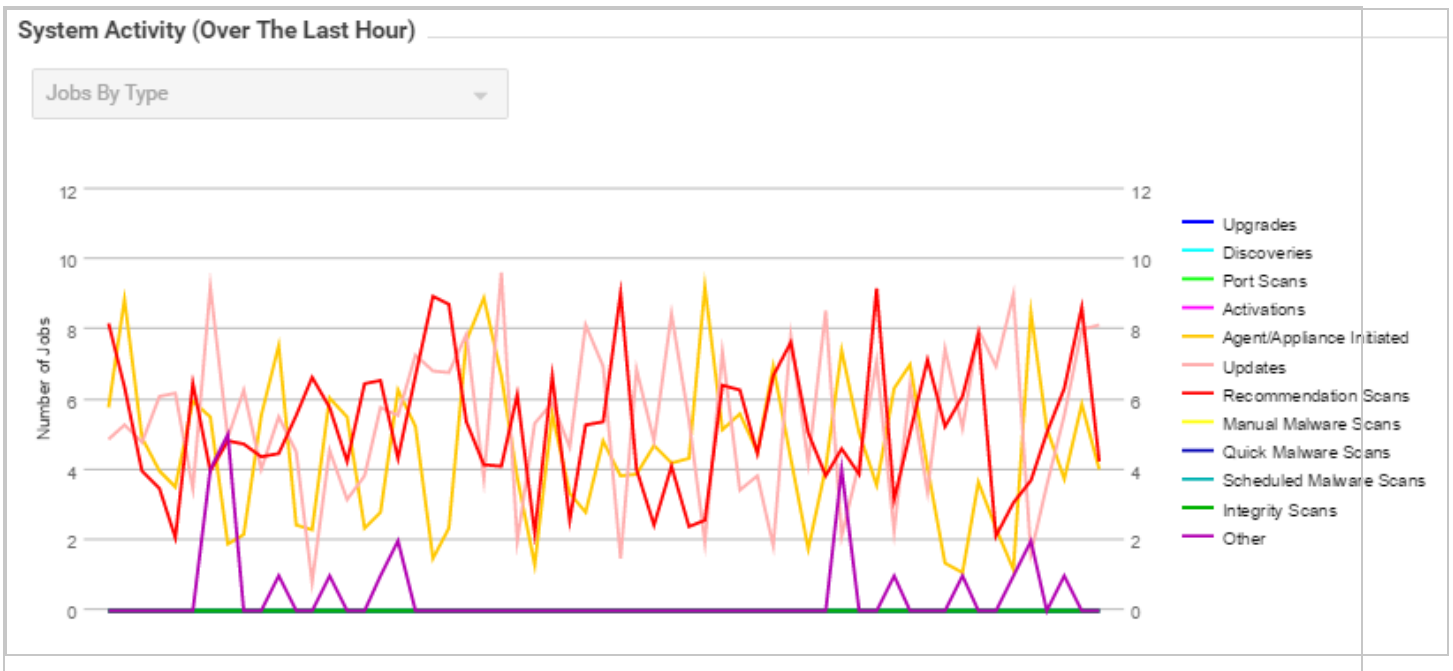

Total jobs by node and type

This chart displays the number of job types for each node over the last hour.

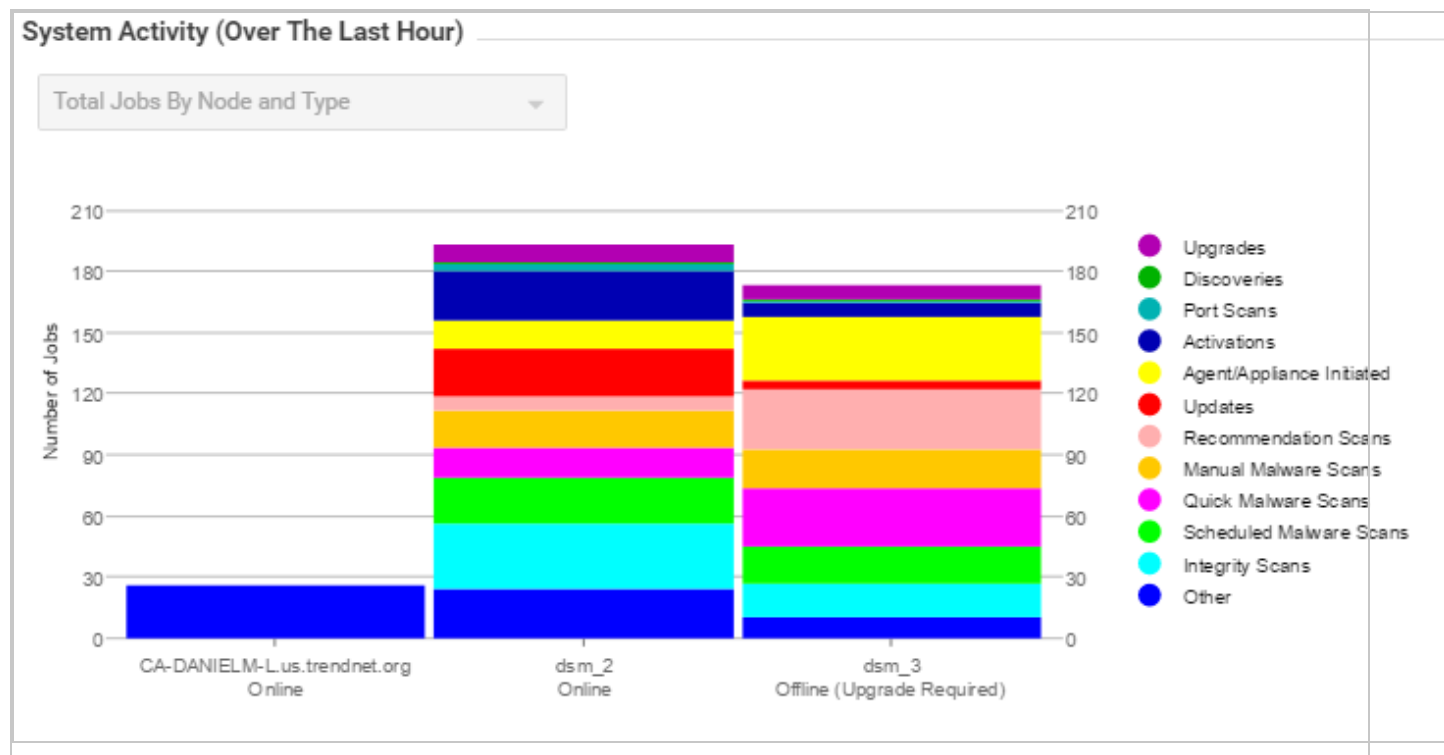

View active Deep Security Manager nodes

To display a list of all active Deep Security Manager nodes, go to **Administration > Manager Nodes**. (See also ["Install Deep Security Manager on multiple nodes"](#) on page 488.)

To display details about one of the manager nodes, double-click its row in the list. The Properties window will display:

- **Hostname:** The hostname of the computer where Deep Security Manager is installed.
- **Description:** A description of the manager node.
- **Performance Profile:** Deep Security Manager's performance can be affected by several factors including number of CPUs, available bandwidth, and database responsiveness. The manager's default performance settings are designed to be suited for most installation environments. However, if you experience performance issues your support provider may suggest that you change the performance profile assigned to one or more of your Deep Security Manager nodes. (You should not change these settings without first consulting your support provider.)

Note: The "Simultaneous Endpoint Disk and Network Jobs" referred to in the tables below include anti-malware scans, integrity monitoring scans, reconnaissance scans, sending policy updates to computers, and distributing security updates.

- **Aggressive:** This performance profile is optimized for installations where the Deep Security Manager is installed on a dedicated server. For example, this is how some common concurrent operations could be distributed per manager node using the **Aggressive** performance profile:

Operation	2-core system	8-core system
Activations	10	20
Updates	25	50
Recommendation Scans	10	20
Check Status	100	Same (100)
Agent- or Appliance-Initiated Heartbeats	20 Active 40 Queued	50 Active 40 Queued
Simultaneous Endpoint Disk and Network Jobs	50	50
Simultaneous Endpoint Disk and Network Jobs per ESXi	3	3

- **Standard:** This Performance Profile is optimized for installations where the Deep Security Manager and the database are on the same computer. For example, this is how some common concurrent operations could be distributed per manager node using the **Standard** performance profile:

Operation	2-core system	8-core system
Activations	5	10
Updates	16	46
Recommendation Scans	3	9
Check Status	65	100
Agent- or Appliance-Initiated Heartbeats	20 Active 40 Queued	50 Active 40 Queued
Simultaneous Endpoint Disk and Network Jobs	50	50
Simultaneous Endpoint Disk and Network Jobs per ESXi	3	3

- **Unlimited Agent Disk and Network Usage:** This setting is identical to **Aggressive** but has no limit on computer disk and network usage operations.

Operation	2-core system	8-core system
Activations	10	20
Updates	25	50
Recommendation Scans	10	20
Check Status	100	Same (100)
Agent- or Appliance-Initiated Heartbeats	20 Active 40 Queued	50 Active 40 Queued
Simultaneous Endpoint Disk and Network Jobs	Unlimited	Unlimited
Simultaneous Endpoint Disk and Network Jobs per ESXi	Unlimited	Unlimited

Note: All performance profiles limit the number of concurrent component updates to 100 per relay group.

- **Status:** Indicates the node's online and active status from the perspective of the Deep Security Manager node you are currently logged into.
- **Options:** You can choose to decommission a manager node. The node must be offline (uninstalled or service halted) to be decommissioned.

Deploy Deep Security Relay

A Deep Security Relay is an agent that is configured to redistribute [Deep Security software and security updates](#) to other agents and virtual appliances. This helps your deployment scale.

You need at least one relay in your environment, and it might already be installed if you co-deployed it with Deep Security Manager. To check:

1. Log in to Deep Security Manager.
2. Click **Administration** at the top.
3. Click **Relay Management** on the left navigation pane.
4. If you see a relay icon () in the main pane, a relay is already deployed.

To deploy your first relay:

1. Make sure the relay computer meets the requirements. See "[Deep Security Agent and Relay sizing](#)" on page 405 and "[Deep Security Relay requirements](#)" on page 333.
2. Make sure you allow inbound and outbound communication to and from the relay on the appropriate port numbers. See "[Deep Security port numbers](#)" on page 411.

3. If the relay must connect through a proxy, see ["Connect to the Primary Security Update Source via proxy" on page 1406](#).
4. Deploy an agent on the chosen computer. See ["Get Deep Security Agent software" below](#) and ["Install the agent" on page 515](#).
5. Enable the agent as a relay:
 - a. Log in to Deep Security Manager.
 - b. Click **Administration** at the top.
 - c. Click **Relay Management** in the left navigation pane.
 - d. If you are using Linux, before enabling the relay, create a user **nobody** and a relay group **nogroup**.
 - e. Select the relay group into which the relay will be placed. If a relay group does not exist, [create one](#). If you are using Linux, create a user **nobody** and a relay group **nogroup**.
 - f. Click **Add Relay**.
 - g. In **Available Computers**, select the agent you just deployed.
 - h. Click **Enable Relay and Add to Group**.

The agent is enabled as a relay and is displayed with a relay icon ()

Note: Trend Micro recommends using more than one relay. This can be set up after you get your basic Deep Security deployment running. For details, see ["Deploy additional relays" on page 1415](#).

Deploy Deep Security Agent

Get Deep Security Agent software

To install Deep Security Agent, you must download the agent installer and load packages for the agent's protection modules into Deep Security Manager.

Warning: Even if you use a third party deployment system, you must import all installed Deep Security Agent software into the Deep Security Manager's database. When a Deep Security Agent is first activated, it only installs protection modules that are currently enabled in the security policy. If you enable a new protection module later, Deep Security Agent will try to download its plug-in from Deep Security Manager. If that software is missing, the agent may not be able to install the protection module.

In this topic:

- ["View agent software available for download" below](#)
- ["View a list of imported agent software" below](#)
- ["Import agent software" on the next page](#)
- ["Export the agent installer" on page 501](#)
- ["Solaris-version-to-agent-package mapping table" on page 502](#)
- ["AIX agent package naming format" on page 502](#)
- ["Delete a software package from the Deep Security database" on page 503](#)

View agent software available for download

To view a complete list of software available for import into Deep Security Manager, you can start from Deep Security Manager or you can start from the Help Center.

To start from Deep Security Manager:

1. In Deep Security Manager, go to **Administration > Updates > Software > Download Center**.
2. Optionally, organize the list of software by version or platform by selecting **Version** or **Platform** from the list at the top.
3. Optionally, search the software by entering a search string in the search box in the upper right.

To start from the Help Center:

1. In the Deep Security Help Center, click **Software** on the left. The Deep Security Software page appears.
2. Click the **Major Releases (LTS)** tab for long-term support releases, and **Feature Releases (FR)** tab for feature releases. For details, see ["Deep Security 20 release strategy and life cycle policy" on page 104](#).

View a list of imported agent software

To view a list of software that you have imported into Deep Security Manager:

1. In Deep Security Manager, go to **Administration > Updates > Software > Local**. All your imported software appears.

2. Optionally, organize the list of software by version or platform by selecting **Version** or **Platform** from the list at the top.

Import agent software

Even if you do not use Deep Security Manager to deploy agent updates, you must still import the software into the Deep Security Manager. The following are the import methods:

- ["Import agent software directly, from the Download Center" below](#)
- ["Import agent software indirectly, from the Help Center" on the next page](#)
- ["Import agent software updates automatically" on the next page](#)

Import agent software directly, from the Download Center

1. Make sure your Deep Security Manager computer has Internet access. If not, see instead ["Import agent software indirectly, from the Help Center" on the next page](#).
2. In Deep Security Manager, go to **Administration > Updates > Software > Download Center**.
3. From the list at the top, select **Platform**.
4. Expand a platform to view the agents available for it.
5. Under the **VERSION** field, look for the version you want and click the import icon. Follow these guidelines:
 - You can select a long-term support (LTS) release or a feature release (FR). For details on LTS and FRs, see ["Deep Security 20 release strategy and life cycle policy" on page 104](#).
 - If you are trying to import a Solaris agent, see ["Solaris-version-to-agent-package mapping table" on page 502](#) for information on which agent to choose.
 - If you are trying to import an AIX agent, see ["AIX agent package naming format" on page 502](#) for the naming format, which is different depending on the agent version.

Deep Security Manager connects to the Internet to download the software from Trend Micro Download Center. The manager then checks the digital signature on the software package. When the manager has finished, a green check mark appears in the **IMPORTED** column for that agent. Software packages now appear on **Administration > Updates > Software > Local**.

If a package cannot be imported, you can try [importing it indirectly](#) instead.

Import agent software indirectly, from the Help Center

If your Deep Security Manager is air-gapped (not connected to the Internet), or if a [direct import](#) did not work, you can try importing the agent software indirectly:

1. On a computer that has access to the Internet, go to the Deep Security Help Center.
2. On the left, click **Software**. The **Deep Security Software** page appears.
3. Download the software ZIP you want. For details on long-term support (LTS) releases and feature releases, see "[Deep Security 20 release strategy and life cycle policy](#)" on [page 104](#).
4. Move the software ZIP to the Deep Security Manager computer.
5. In Deep Security Manager, go to **Administration > Updates > Software > Local**.
6. In the main pane, click **Import** to import the ZIP file. The manager checks the digital signature on the ZIP file, and if it is valid, allows the import to proceed.

Import agent software updates automatically

You can have Deep Security Manager look for newer software on the Download Center and import it to your local inventory automatically. Deep Security Manager only imports updates to already-imported software.

An update is a build in which only the last set of numbers changes. For example, if you already imported agent version 12.0.0.111, then the following versions would be imported automatically because they are update builds of 12.0.0.111:

12.0.0.112
12.0.0.113
12.0.0.123

However, the following versions would not be imported automatically:

12.1.0.222
11.0.0.333
10.0.0.111

To have Deep Security Manager automatically import agent update builds to your local inventory:

1. In Deep Security Manager, go to **Administration > System Settings > Updates**.
2. Select **Automatically download updates to imported software**.

3. Click **Save**.

Note that setting imports the software to Deep Security Manager but does *not* automatically update your agent or appliance software. Continue with "[Upgrade Deep Security Agent](#)" on page 1625.

Export the agent installer

You can download the agent installer from Deep Security Manager as follows:

1. In Deep Security Manager, go to **Administration > Updates > Software > Local**.
2. Select your agent from the list. If you have imported multiple versions of the same agent, the latest version of the software has a green check mark in the **Is Latest** column.

If you are looking for a Solaris agent, see "[Solaris-version-to-agent-package mapping table](#)" on the next page for information on which agent to choose.

3. Click **Export > Export Installer**.

The manager then checks the digital signature on the software package. If the signature is valid, the export proceeds.

4. Save the agent installer. If you are planning to install the agent manually, save it on the computer where you want to install Deep Security Agent.

To install Deep Security Agent, only use the exported agent installer (the `.msi`, `.rpm`, `.pkg`, `.p5p`, or `.bff` file depending on the platform) as opposed to the full agent ZIP package. If you run the agent installer from the same folder that holds the other zipped agent components, all protection modules will be installed, even if you have not enabled them on the computer. This consumes extra disk space. For comparison, if you use the `.msi`, `.rpm`, `.pkg`, `.p5p`, or `.bff` file, the agent will download and install protection modules only if your configuration requires them.

Installing an agent, activating it, and applying protection with a security policy can be done using a command-line script. For more information, see "[Use deployment scripts to add and protect computers](#)" on page 1790.

You can generate deployment scripts to automate the agent installation using the Deep Security API. For more information, see [Generate an agent deployment script](#).

Solaris-version-to-agent-package mapping table

If you are not sure which agent package to pick when importing and exporting the agent, review the following mapping table.

Solaris-version-to-agent-package mapping table

If you're installing the agent on	Choose this agent package	Help Center option
Solaris 10 Updates 4-6 (64-bit, SPARC or x86)	Agent-Solaris_5.10_U5-xx.x.x-xxx.<sparc x86_64>.zip	Solaris_5.10_U5
Solaris 10 Updates 7-11 (64-bit, SPARC or x86)	Agent-Solaris_5.10_U7-xx.x.x-xxx.<sparc x86_64>.zip	Solaris_5.10_U7
Solaris 11.0 (1111)-11.3 (64-bit, SPARC or x86)	Agent-Solaris_5.11-xx.x.x-xxx.<sparc x86_64>.zip	Solaris_5.11
Solaris 11.4 (64-bit, SPARC or x86)	Agent-Solaris_5.11_U4-xx.x.x-xxx.<sparc x86_64>.zip	Solaris_5.11_U4

Note the following:

- The **Help Center option** column shows you which option to select from the **Agent** list on the [Help Center's 'Deep Security Software'](#) page, if that is how you have chosen to obtain the package.
- `xx.x.x.xxx` is the build number of the agent. For example, `12.0.0-682`
- `<sparc|x86_64>` is one of `sparc` or `.x86_64`, depending on the Solaris processor.

AIX agent package naming format

The naming format is different depending on the agent version:

- **Deep Security Agent 12 for AIX:** `Agent-AIX-<agent_release>-<agent_build>.powerpc.zip`. For example, `Agent-AIX-12.0.0-1234.powerpc.zip`.
- **Deep Security Agent 9.0 for AIX:** `Agent-AIX_<AIX_version>-<agent_release>-<build>.powerpc.bff.gz.zip`. For example, `Agent-AIX_5.3-9.0.0-5625.powerpc.bff.gz.zip`.

For details on which agent you need for the version of AIX you are using, see ["Agent platform compatibility" on page 336](#).

Delete a software package from the Deep Security database

To save disk space, Deep Security Manager periodically removes unused packages from the Deep Security database. To configure the maximum number of old packages kept, go to **System Settings > Storage**.

Note: Deep Security Virtual Appliance uses the same protection modules as Deep Security Agent for 64-bit Red Hat Enterprise Linux. Therefore, if you have an activated Deep Security Virtual Appliance and try to delete the 64-bit Red Hat Enterprise Linux Agent software package from the database, an error message will notify you that the software is in use.

There are two types of packages that can be deleted:

- agent
- kernel support

Deleting agent packages in single-tenancy mode

In single-tenancy mode, Deep Security automatically deletes agent packages (*Agent-platform-version.zip*) that are not currently being used by agents. Alternatively, you can manually delete unused agent packages. Only unused software packages can be deleted.

For the Windows and Linux agent packages, only the currently used package (whose version is the same as the agent installer) cannot be deleted.

Deleting agent packages in multi-tenancy mode

In multi-tenancy mode, unused agent packages (*Agent-platform-version.zip*) are not deleted automatically. For privacy reasons, Deep Security cannot determine if software is currently in use by your tenants, even though you and your tenants share the same software repository in the Deep Security database. As the primary tenant, Deep Security does not prevent you from deleting software that is not currently running on any of your own account's computers, but before deleting a software package, ensure that no other tenants are using it.

Deleting kernel support packages

In both single and multi-tenancy mode, Deep Security automatically deletes unused kernel support packages (*KernelSupport-[platform-version.zip](#)*). A kernel support package can be deleted if both of these conditions are met:

- No agent package has the same group identifier.
- Another kernel support package has the same group identifier and a later build number.

You can also manually delete unused kernel support packages. For Linux kernel support packages, only the latest one cannot be deleted.

Configure Linux Secure Boot for agents

Some versions of the Deep Security Agent for Linux are [compatible](#) with [Unified Extensible Firmware Interface \(UEFI\) Secure Boot](#).

When Secure Boot is enabled, the computer's Linux kernel checks the PKI signature of each kernel module before it is loaded. It does not load unsigned kernel modules, nor modules with invalid signatures. These agent features install the following kernel modules:

- Anti-Malware
- Web Reputation
- Firewall
- Integrity Monitoring
- Intrusion Prevention
- Application Control

To use those features with Secure Boot, you must enroll the [public keys from Trend Micro](#) into the computer's firmware to enable validating of these kernel module signatures.

Methods vary by platform:

- [Enroll a Secure Boot key for AWS](#)
- [Enroll a Secure Boot key for Google Cloud Platform](#)
- [Enroll a Secure Boot key for VMware vSphere](#)
- [Enroll a Secure Boot key for physical computers](#)
- [Enroll a Secure Boot key for Oracle Linux](#)

Download the Trend Micro public keys

Before you enroll them on Secure Boot computers, you must first download the Trend Micro public keys to be used to validate kernel module signatures. If you have trouble downloading the key files, right-click and select **Save Link As**.

The public keys are encoded in DER format:

- [DS2022.der](#)

SHA-256 certificate hash: BB FA 4A B8 3C 61 A0 3F 1D D0 4B A7 A4 51 75 E7 D7
EF D3 C8 4B F3 D9 FE A0 CE AB B9 2A F4 8E 92

- [DS20_V2.der](#)

SHA-256 certificate hash: B3 36 43 7B 12 B3 EB 6A 4E 4A 44 62 40 4F 1F BD 21
32 70 77 4C 33 7D 1C 5A 58 7C 99 83 F7 30 C7

When the agent is deployed on SuSE 15 with kernels 5.3.18-24.34-default or later, [DS20_v2.der](#) is required because verification of kernel module signatures has changed.

- [DS20.der](#)

SHA-256 certificate hash: CB 44 47 C8 76 CF 28 79 2F 8E B6 76 F1 42 4B D4 93
82 70 0E 46 92 ED 69 83 0C C3 52 E9 E4 71 03

- [DS12.der](#)

SHA-256 certificate hash: CB 44 47 C8 76 CF 28 79 2F 8E B6 76 F1 42 4B D4 93
82 70 0E 46 92 ED 69 83 0C C3 52 E9 E4 71 03

- [DS11_2022.der](#)

SHA-256 certificate hash: BB FA 4A B8 3C 61 A0 3F 1D D0 4B A7 A4 51 75 E7 D7
EF D3 C8 4B F3 D9 FE A0 CE AB B9 2A F4 8E 92

Note that the old public key for agent version 11 ([DS11.der](#) with SHA-1 hash 7D 96 56 5C 3A 77 B7 A7 24 49 D5 6A A5 0C 28 AA D7 3B 0B fB) expired on December 5, 2022. To continue using the agent after this date, you must enroll this new public key. Otherwise an "Engine Offline" error message will appear in the console and the computer will not be protected.

You also must download the intermediate certificate authority (CA) certificates that are required to validate the signing chain on the Trend Micro public keys. The CA certificates are X.509 v3 CRT files encoded in DER format:

- [MicWinProPCA2011_2011-10-19.crt](#)

Microsoft Windows Production PCA 2011

SHA-256 certificate hash: E8 E9 5F 07 33 A5 5E 8B AD 7B E0 A1 41 3E E2 3C 51
FC EA 64 B3 C8 FA 6A 78 69 35 FD DC C7 19 61

- [MicCorUEFCA2011_2011-06-27.crt](#)

Microsoft Corporation UEFI CA 2011

SHA-256 certificate hash: 48 E9 9B 99 1F 57 FC 52 F7 61 49 59 9B FF 0A 58 C4
71 54 22 9B 9F 8D 60 3A C4 0D 35 00 24 85 07

- [MicCorKEKCA2011_2011-06-24.crt](#)

Microsoft Corporation KEK CA 2011

SHA-256 certificate hash: A1 11 7F 51 6A 32 CE FC BA 3F 2D 1A CE 10 A8 79 72
FD 6B BE 8F E0 D0 B9 96 E0 9E 65 D8 02 A5 03

Update the Trend Micro public key

You need to update your enrolled public keys for signed Trend Micro kernel modules if any of the following applies:

You upgrade the agent to a newer major release

In every major release of the agent (for example, agent 12.0 and 20.0), Trend Micro refreshes the public keys for Secure Boot kernel module signatures. New kernel module signatures cannot be validated with an old public key. As a result, when you upgrade the agent, you must also enroll the new public key.

The public key has expired

Agent Version	Key	Expiry date	Comment
20	DS2022.der	24-Nov-2031	A new replacement key is expected to be released one year before the expiry date.
	DS20.der	26-Nov-2024	DS20.der will be replaced by DS2022.der upon its expiry. Ensure that DS2022.der is enrolled prior to the expiry date of DS20.der.
	DS20_V2.der	24-Oct-2026	<ul style="list-style-type: none"> • Required for SUSE 15 kernels after 5.3.18-24.34-default. • DS20_V2.der will be replaced by DS2022.der upon its expiry. Ensure that DS2022.der is enrolled prior to the expiry date of DS20_V2.der.
12	DS12.der	26-Nov-2024	DS12.der will be replaced by DS2022.der upon its expiry. Ensure that DS2022.der is enrolled prior to the expiry date of DS12.der.
11	DS11_2022.der	24-Nov-2031	
	DS11.der	05-Dec-2022	

For Deep Security Agent 20 to use Secure Boot, it is essential to have DS2022.der, DS20_V2.der, and DS20.der keys enrolled.

Linux kernel module signature verification has changed

When you update a Linux kernel, the method that it uses to verify kernel module signatures might change. This might require you to replace the enrolled public keys.

For example, SuSE 15 added ECU code signing verification in kernel version 5.3.18-24.34-default, which required a new public key version, `DS20_v2.der`.

Warning: If a public key for Secure Boot becomes invalid for any of these reasons, and you do not replace it, then an "Engine Offline" error message might appear in the console and the computer can lose protection.

Enroll a Secure Boot key for AWS

1. Download the required [CA certificates and Trend Micro public keys for Secure Boot](#).
2. If you do not have a platform key, see the AWS documentation to [generate a Secure Boot platform key](#) .

Warning: Only replace the platform key if you can access the firmware of all devices that are loaded during boot (for example, the GPU). If you cannot update the firmware's signing chain to use your new platform key, then Secure Boot could make the instance permanently unable to boot.

3. Create an EC2 virtual machine instance from a Linux distribution AMI that supports Secure Boot.
4. In the console on that instance, install the Machine Owner Key (MOK) command `mokutil`, `uefivars`, and Python.

For example, on Red Hat Enterprise Linux, execute the following commands:

```
yum install mokutil
```

```
yum install python3
```

```
curl -L -o uefivars.zip https://github.com/aws-labs/python-uefivars/archive/refs/heads/main.zip
```

```
unzip uefivars.zip
```

On Debian or Ubuntu, execute the following commands:

```
sudo apt-get update
```

```
sudo apt-get install efityools
```

```
sudo apt-get install python3
```

```
curl -L -o uefivars.zip https://github.com/awslabs/python-uefivars/archive/refs/heads/main.zip
```

```
unzip uefivars.zip
```

5. Upload the CA certificates and Trend Micro public keys to the instance.
6. Put each platform key, CA certificate, and Trend Micro public key inside a UEFI signature list (`.esl`) file. Combine them into one file, and then convert it into binary (`.bin`) format.

For example, depending on which Trend Micro public keys you use, you might enter the following commands:

```
# Convert your platform key into signatures list format
```

```
cert-to-efi-sig-list YOUR_PLATFORM_KEY.crt YOUR_PLATFORM_KEY.esl
```

```
# Convert CA certificates
```

```
sbsiglist --owner 77fa9abd-0359-4d32-bd60-28f4e78f784b --type x509 --  
output MS_CA_KEK.esl MicCorKEKCA2011_2011-06-24.crt
```

```
sbsiglist --owner 77fa9abd-0359-4d32-bd60-28f4e78f784b --type x509 --  
output MS_CA_PROD.esl MicWinProPCA2011_2011-10-19.crt
```

```
sbsiglist --owner 77fa9abd-0359-4d32-bd60-28f4e78f784b --type x509 --  
output MS_CA_UEFI.esl MicCorUEFCA2011_2011-06-27.crt
```

```
# Convert Trend Micro public keys
```

```
sbsiglist --owner 77fa9abd-0359-4d32-bd60-28f4e78f784b --type x509 --  
output TREND_UEFI_db_DS11.esl DS11_2022.der
```

```
sbsiglist --owner 77fa9abd-0359-4d32-bd60-28f4e78f784b --type x509 --  
output TREND_UEFI_db_DS12.esl DS12.der
```

```
sbsiglist --owner 77fa9abd-0359-4d32-bd60-28f4e78f784b --type x509 --  
output TREND_UEFI_db_DS20.esl DS20.der
```

```
sbsiglist --owner 77fa9abd-0359-4d32-bd60-28f4e78f784b --type x509 --  
output TREND_UEFI_db_DS20_v2.esl DS20_v2.der
```

```
sbsiglist --owner 77fa9abd-0359-4d32-bd60-28f4e78f784b --type x509 --  
output TREND_UEFI_db_DS2022.esl DS2022.der
```

```
# Combine CA and vendor public keys into one signatures list
```

```
cat MS_CA_PROD.esl MS_CA_UEFI.esl TREND_UEFI_db_DS11.esl TREND_UEFI_db_DS12.esl TREND_UEFI_db_DS20.esl TREND_UEFI_db_DS20_v2.esl TREND_UEFI_db_DS2022.esl > ALL_SIGNATURES_db.esl
```

```
cp *.esl /root/
```

```
# Combine all and convert to binary
```

```
./python-uefivars-main/uefivars.py -i none -o aws -O YOUR_BINARY_SIGNING_CHAIN.bin -P ./YOUR_PLATFORM_KEY.esl -K ./MS_CA_KEK.esl --db ./ALL_SIGNATURES_db.esl
```

where `77fa9abd-0359-4d32-bd60-28f4e78f784b` is the GUID in the `SignatureOwner` field of the Microsoft Corporation KEK CA 2011 certificate.

7. Download the `.bin` file.
8. Create a new EC2 snapshot of the instance.
9. Go to AWS Cloudshell, select **Actions > Files > Upload file**, and then select the binary file.
10. Create a new AMI with the snapshot ID and the `.bin` file that you uploaded.

For example, you could enter the following command:

```
aws ec2 register-image --name LIFT-UBUNTU20SecureBootX64 --uefi-data $(cat YOUR_BINARY_SIGNING_CHAIN.bin) --block-device-mappings "DeviceName=/dev/sda1,Ebs= {SnapshotId={{YOUR-SNAPSHOT-ID}},DeleteOnTermination=true}" --architecture x86_64 --root-device-name /dev/sda1 --virtualization-type hvm --boot-mode uefi
```

11. Use the customized image to create a new instance with Secure Boot enabled.
12. Execute the following command to verify that the keys are successfully enrolled in the MOK list:

```
mokutil --db | grep Trend
```

and that the kernel has successfully loaded the Trend Micro public keys:

```
dmesg | grep cert
```

Enroll a Secure Boot key for Google Cloud Platform

1. Download the required [CA certificates and Trend Micro public keys for Secure Boot](#).
2. If you do not have a platform key, see the Google Cloud Platform documentation to [generate a platform key](#).

Warning: Only replace the platform key if you can access the firmware of all devices that are loaded during boot (for example, the GPU). If you cannot update the firmware's signing chain to use your new platform key, then Secure Boot could make the instance permanently unable to boot.

3. Create [customized virtual machine images](#) with the CA certificates and Trend Micro public keys that will be used by Secure Boot:

For example, enter the following command:

```
gcloud compute images create [IMAGE_NAME] \
--source-image=[SOURCE_IMAGE] \
--source-image-project=[SOURCE_PROJECT] \
--platform-key-file=YOUR_PLATFORM_KEY.der \
--signature-database-file=./MicCorUEFCA2011_2011-06-
27.crt,./MicWinProPCA2011_2011-10-19.crt,./DS2022.der,./DS20_
v2.der,./DS20.der,./DS12.der,./DS11_2022.der[,OTHER_EXISTING_KEYS] \
--guest-os-features=UEFI_COMPATIBLE
```

Public keys must be in DER or BIN format. Separate each with a comma (,). For details on command usage and the API, see the Google Cloud Platform documentation.

You must include all existing Secure Boot keys when you enter this command, as it overwrites all existing keys. If you do not include them, they will be deleted and their kernel modules will not load.

4. Use the customized image to create new virtual machine instances with Secure Boot enabled.
5. Execute the following command to verify that the keys are successfully enrolled:

```
grep 'Trend' /proc/keys
```

Enroll a Secure Boot key for VMware vSphere platform

Follow these steps to enroll a Secure Boot key for the VMware vSphere virtualization platform, unless the computer uses the release earlier than the Unbreakable Enterprise Kernel Release 6 Update 3 (UEK R6U3) for Oracle Linux:

1. Download the required [CA certificates and Trend Micro public keys for Secure Boot](#).
2. On the computer where Secure Boot will be enabled, install the Machine Owner Key (MOK) command `mokutil`.

For example, on Red Hat Enterprise Linux, enter the following command:

```
yum install mokutil
```

On Debian or Ubuntu, enter the following command:

```
sudo apt-get update
```

```
sudo apt-get install efityools
```

3. Add the Trend Micro public keys to the MOK list, separating multiple keys with a space (if applicable). The following example shows the command to execute if Deep Security Agent version earlier than 20.0.0.7119 is used:

```
mokutil --import /opt/ds_agent/DS2022.der /opt/ds_agent/DS20_v2.der  
/opt/ds_agent/DS20.der
```

The following example shows the command to execute if Deep Security Agent version 20.0.0.7119 or later is used:

```
mokutil --import /opt/ds_agent/secureboot/DS2022.der /opt/ds_  
agent/secureboot/DS20_v2.der /opt/ds_agent/DS20.der
```

When prompted, enter a password that you will use later.

4. Reboot the computer.
5. When the Shim UEFI key management console opens, press any key to continue.
6. On the Perform MOK Management screen, select Enroll MOK.
7. Select View key X if you need to verify the details of the public keys. Press any key to

return to the Enroll MOK screen.

8. Select Continue on the Enroll the key(s)? screen.
9. Select Yes, and then enter the password that you entered earlier.
10. On the The system must now be rebooted screen, select OK.
11. Verify that the keys are successfully enrolled in the MOK list:

- For most Linux distributions, enter the following command:

```
mokutil --test-key /opt/ds_agent/${certificate_file}.der
```

- For Debian Linux 11 or Debian Linux 12, enter the following command:

```
keyctl show %:.platform | grep 'Trend'
```

Enroll a Secure Boot key for physical computers

Follow these steps to enroll a Secure Boot key for a physical computer, unless it uses the release earlier than the Unbreakable Enterprise Kernel Release 6 Update 3 (UEK R6U3) for Oracle Linux:

1. Download the required [CA certificates and Trend Micro public keys for Secure Boot](#).
2. If you do not have a platform key, see your Linux distribution's documentation to generate a Secure Boot platform key.

Warning: Only replace the platform key if you can access the firmware of all devices that are loaded during boot (for example, the GPU). If you cannot update the firmware's signing chain to use your new platform key, then Secure Boot could make the instance permanently unable to boot.

3. On the computer where Secure Boot will be enabled, install the Machine Owner Key (MOK) command `mokutil`.

For example, on Red Hat Enterprise Linux, enter the following command:

```
yum install mokutil
```

On Debian or Ubuntu, enter the following command:

```
sudo apt-get update
```

```
sudo apt-get install efityools
```

4. Add the Trend Micro public keys to the MOK list, separating multiple keys with a space (if applicable). The following example shows the command to execute if Deep Security Agent version earlier than 20.0.0.7119 is used:

```
mokutil --import /opt/ds_agent/DS2022.der /opt/ds_agent/DS20_v2.der /opt/ds_agent/DS20.der
```

The following example shows the command to execute if Deep Security Agent version 20.0.0.7119 or later is used:

```
mokutil --import /opt/ds_agent/secureboot/DS2022.der /opt/ds_agent/secureboot/DS20_v2.der /opt/ds_agent/DS20.der
```

When prompted, enter a password that you will use later.

5. Reboot the computer.
6. When the Shim UEFI key management console opens, press any key to continue.
7. On the Perform MOK Management screen, select Enroll MOK.
8. Select View key X if you need to verify the details of the public keys. Press any key to return to the Enroll MOK screen.
9. Select Continue on the Enroll the key(s)? screen.
10. Select Yes, and then enter the password that you entered earlier.
11. On the The system must now be rebooted screen, select OK.
12. Verify that the keys are successfully enrolled in the MOK list:
 - For most Linux distributions, enter the following command:

```
mokutil --test-key /opt/ds_agent/${certificate_file}.der
```

- For Debian Linux 11 or Debian Linux 12, enter the following command:

```
keyctl show %:.platform | grep 'Trend'
```

Enroll a Secure Boot key for Oracle Linux

On the releases earlier than the Unbreakable Enterprise Kernel Release 6 Update 3 (UEK R6U3) for Oracle Linux, Secure Boot requires slightly different procedure. With UEK, the kernel only trusts keys that are in the built-in keyring. Therefore, the kernel must be recompiled with the Trend Micro public keys, and since that changes the kernel itself, you must also sign the new kernel boot image.

1. Download the required [CA certificates and Trend Micro public keys for Secure Boot](#).
2. Follow the Oracle Linux documentation for [Signing Kernel Images and Kernel Modules for Use With Secure Boot](#).
3. When you reach the step for [Insert the Module Certificate in the Kernel Image](#), replace `pubkey.der` with the name of your Trend Micro public key. For example:

```
sudo /usr/src/kernels/$(uname -r)/scripts/insert-sys-cert -s  
/boot/System.map$(uname -r) -z /boot/vmlinuz$(uname -r) -c ./DS20_  
v2.der
```

4. Continue with the remaining steps to sign the kernel boot image.
5. Execute the following command to verify that the key is listed in the `builtin_trusted_keys` keyring:

```
sudo keyctl show %:.builtin_trusted_keys | grep 'Trend'
```

Install the agent

Topics:

- ["Install the agent manually" below](#)
- ["Install the agent using other methods" on page 521](#)
- ["Post-installation tasks" on page 522](#)

Install the agent manually

Before you begin, make sure you have:

1. Reviewed the agent's system requirements. See ["Deep Security Agent requirements" on page 332](#).

2. Windows only: ["Coexistence of Deep Security Agent with Microsoft Defender Antivirus" on page 827](#)
3. Allowed inbound and outbound communication to and from the agent on the appropriate port numbers. See ["Deep Security port numbers" on page 411](#).
4. Imported the agent software into the manager. See ["Import agent software" on page 499](#).
5. Exported the agent software from the manager. See ["Export the agent installer" on page 501](#).

Next, install the agent. Follow the instructions for your platform.

Install the agent on Windows

1. Copy the agent ZIP to the computer and extract it.
2. Double-click the installation file (.MSI file) to run the installer package.

Note: On Windows Server 2012 R2 Server Core, launch the installer using this command instead: `msiexec /i Agent-Core-Windows-12.x-xxxx.x86_64.msi`

3. At the Welcome screen, click **Next** to begin the installation.
4. **End-User License Agreement:** If you agree to the terms of the license agreement, select **I accept the terms of the license agreement** and click **Next**.
5. **Destination Folder:** Select the location where you would like Deep Security Agent to be installed and click **Next**.
6. **Ready to install Trend Micro Deep Security Agent:** Click **Install** to proceed with the installation.
7. **Completed:** when the installation has completed successfully, click **Finish**.

The Deep Security Agent is now installed and running on this computer, and will start every time the machine boots.

Note: When installing the agent on Windows 2012 Server Core, the notifier will not be included.

Note: During an install, network interfaces will be suspended for a few seconds before being restored. If you are using DHCP, a new request will be generated, potentially resulting in a new IP address for the restored connection.

Installation on Amazon WorkSpaces

- If you are unable to install Deep Security Agent .msi file due to error code '2503' then you must do one of the following:
 - Edit your C:\Windows\Temp folder and allow the write permission for your user
OR
 - Open the command prompt as an administrator and run the .msi file

Note: Amazon has fixed this issue for newly-deployed Amazon WorkSpaces.

Installation on Windows 2012 Server Core

- Deep Security does not support switching the Windows 2012 server mode between Server Core and Full (GUI) modes after the Deep Security Agent is installed.
- If you are using Server Core mode in a Hyper-V environment, you will need to use Hyper-V Manager to remotely manage the Server Core computer from another computer. When the Server Core computer has the Deep Security Agent installed and Firewall enabled, the Firewall will block the remote management connection. To manage the Server Core computer remotely, turn off the Firewall module.
- Hyper-V provides a migration function used to move a guest VM from one Hyper-V server to another. The Deep Security Firewall module will block the connection between Hyper-V servers, so you will need to turn off the Firewall module to use the migration function.

Install the agent on Red Hat, Amazon, SUSE, Oracle, Alma, Rocky, Miracle, or Cloud Linux

1. Copy the agent ZIP to the computer and extract it.
2. Install the agent.

```
# sudo rpm -i <package name>
Preparing... ##### [100%]
1:ds_agent ##### [100%]
Loading ds_filter_im module version ELx.x [ OK ]
```

```
Starting ds_agent: [ OK ]
```

The Deep Security Agent will start automatically upon installation.

Install the agent on Ubuntu or Debian

1. Copy the agent ZIP to the computer and extract it.
2. Install the agent.

```
sudo dpkg -i <installer deb file>
```

To start, stop, or reset the agent:

Using SysV init scripts:

- **Start:** `/etc/init.d/ds_agent start`
- **Stop:** `/etc/init.d/ds_agent stop`
- **Reset:** `/etc/init.d/ds_agent reset`
- **Restart:** `/etc/init.d/ds_agent restart`
- **Display status:** `svcs -a | grep ds_agent`

Using systemd commands:

- **Start:** `systemctl start ds_agent`
 - **Stop:** `systemctl stop ds_agent`
 - **Restart:** `systemctl restart ds_agent`
 - **Display status:** `systemctl status ds_agent`
-

Install the agent on Solaris

Note: The Deep Security Agent installation is only supported in the global zone.

Solaris requires the following libraries to be installed to support Deep Security Agent:

Solaris 10: SUNWgccruntime

Solaris 11.0 - 11.3: gcc-45-runtime

Solaris 11.4: none; gcc-c-runtime version 7.3 is installed by default

1. Copy the agent installer package to the computer where you want to install the agent.
2. Unzip the ZIP file.
3. Unzip the GZ file.

```
gunzip <agent_GZ_file>
```

The agent installer file (P5P or PKG) is now available.

4. Install the agent. Some examples of installation commands are provided below. Alter the commands to suit your Solaris version, Solaris zone, Solaris processor, and Deep Security agent package name.
 - On Solaris 11, with one zone, run the following command in the global zone:

```
x86: pkg install -g file:///mnt/Agent-Solaris_5.11-xx.x.x-xxxx.x86_64/Agent-Core-Solaris_5.11-xx.x.x-xxxx.x86_64.p5p
pkg:/security/ds-agent
```

```
SPARC: pkg install -g file:///mnt/Agent-Solaris_5.11-xx.x.x-xxxx.sparc/Agent-Core-Solaris_5.11-xx.x.x-xxxx.sparc.p5p
pkg:/security/ds-agent
```

- On Solaris 11, with multiple zones, run the following command in the global zone:

```
mkdir <path>
```

```
pkgrepo create <path>
```

```
pkgrecv -s file://<path_to_agent_p5p_file> -d <path> '*'
```

```
pkg set-publisher -g <path> trendmicro
```

```
pkg install pkg://trendmicro/security/ds-agent
```

```
pkg unset-publisher trendmicro
```

```
rm -rf <path>
```

- On Solaris 10, run one of these commands:

```
x86: pkgadd -G -d Agent-Core-Solaris_5.10_Ux-xx.x.x-xxx.x86_64.pkg
```

```
SPARC: pkgadd -G -d Agent-Core-Solaris_5.10_Ux-xx.x.x-  
xxx.sparc.pkg
```

To start, stop, or reset the agent:

- **Start:** `svcadm enable ds_agent`
- **Stop:** `svcadm disable ds_agent`
- **Reset:** `/opt/ds_agent/dsa_control -r`
- **Restart:** `svcadm restart ds_agent`
- **Display status:** `svcs -a | grep ds_agent`

To uninstall the agent on Solaris 11:

```
pkg uninstall pkg:/security/ds-agent
```

To uninstall the agent on Solaris 10:

```
pkgrm -v ds-agent
```

Install the agent on AIX

1. Copy the agent ZIP to the computer and extract it. A GZ file becomes available.
2. Move the GZ file to another location.
3. Extract the GZ file using gunzip. A BFF file becomes available. This is the installer file.
4. Copy the BFF file to the AIX computer.
5. Place the BFF file in a temporary folder such as `/tmp`.
6. Install the agent.

```
/tmp> installp -a -d /tmp/<agent_BFF_file_name> ds_agent
```

where `<agent_BFF_file_name>` is replaced with the name of the BFF installer file you extracted.

To start, stop, load, or unload the driver for the agent:

- **Start:** `startsrc -s ds_agent`
- **Stop:** `stopsrc -s ds_agent`

- Load the driver: `/opt/ds_agent/ds_fctrl load`
 - Unload the driver: `/opt/ds_agent/ds_fctrl unload`
-

Install the agent on Red Hat OpenShift

Before you begin:

1. Ensure that you have [helm](#) v3 or newer installed.
2. Make sure you have imported the agent software to Deep Security Manager. See ["Get Deep Security Agent software" on page 497](#) for details.
3. Ensure that you have enabled agent-initiated activation (AIA). AIA is required if you want your deployment script to activate the agent after installation. See ["Activate and protect agents using agent-initiated activation and communication" on page 1460](#) for details.

Installing the agent:

1. From the Deep Security console, in the upper right corner, click **Support > Deployment Scripts**.
 2. Select **OpenShift Agent Deployment**.
 3. (*optional*) Select the options for **Security Policy**, **Computer Group**, **Relay Group**, **Proxy to contact Deep Security Manager**, and **Proxy to contact Relay(s)**.
The deployment script generator displays the script.
 4. Do one of the following:
 - Click **Copy to Clipboard** and paste the deployment script in your preferred deployment tool
 - Click **Save to File**.
-

Install the agent using other methods

If you don't want to install the agent manually, you can use one of the methods described below.

- **Deployment scripts:** Generate deployment scripts within the manager and use them to install the agent. For details, see ["Use deployment scripts to add and protect computers" on page 1790](#)

- **Deep Security API:** Use the API to generate deployment scripts to automate the installation of the agent on a computer. See [Use Scripts to Deploy Deep Security Manager and Agent](#) on the Deep Security Automation Center.
- **SCCM:** Use Microsoft System Center Configuration Manager (SCCM) to install an agent, activate it, and apply a policy. To use SCCM, go to **Administration > System Settings > Agents** and enable agent-initiated activation.
- **Template:** Include the agent in your VM template. See "[Install the agent on an AMI or WorkSpace bundle](#)" on page 528 and "[Install the agent on Azure VMs](#)" on page 532.

Post-installation tasks

After you install the agent, you must perform the following post-installation tasks, if they were not already completed as part of the installation process:

- "[Activate the agent](#)" on page 538
- "[Assign a policy to a computer](#)" on page 699

Install the agent on Amazon EC2 and WorkSpaces

Note: The Deep Security Agent only supports Amazon WorkSpaces Windows desktops—it does not support Linux desktops.

Read this page if you want to protect *existing* Amazon EC2 instances and Amazon WorkSpaces with Deep Security.

If instead you want to:

- launch *new* Amazon EC2 instances and Amazon WorkSpaces with the agent 'baked in', see "[Install the agent on an AMI or WorkSpace bundle](#)" on page 528.
- protect Amazon WorkSpaces after already protecting your Amazon EC2 instances, see instead "[Protect Amazon WorkSpaces if you already added your AWS account](#)" on page 654.

To protect your existing Amazon EC2 instances and Amazon WorkSpaces with Deep Security, follow these steps:

1. "[Add your AWS accounts to Deep Security Manager](#)" on the next page
2. "[Set the communication direction](#)" on the next page

3. ["Configure the activation type" on the next page](#)
4. ["Open ports" on page 525](#)
5. ["Deploy agents to your Amazon EC2 instances and WorkSpaces" on page 526](#)
6. ["Verify that the agent was installed and activated properly" on page 527](#)
7. ["Assign a policy" on page 527](#)

Add your AWS accounts to Deep Security Manager

You'll need to add your AWS account or accounts to Deep Security Manager. These AWS accounts contain the Amazon EC2 instances and Amazon WorkSpaces that you want to protect with Deep Security.

See ["About adding AWS accounts" on page 640](#) for details.

After adding your AWS accounts:

- your existing Amazon EC2 instances and Amazon WorkSpaces appear in Deep Security Manager. If no agent is installed on them, they appear with a **Status of Unmanaged (Unknown)** and a grey dot next to them. If an agent was already installed, they appear with a **Status of Managed (Online)** and green dot next to them.
- any new Amazon EC2 instances or Amazon WorkSpaces that you launch through AWS under this AWS account are auto-detected by Deep Security Manager and displayed in the list of computers.

Set the communication direction

You'll need to set the communication direction: either agent-initiated, manager-initiated, or bi-directional.

1. Log in to Deep Security Manager.
2. Set the communication direction following the instructions in ["Configure communication directionality" on page 1450](#). Follow these guidelines:
 - **Agent/Appliance Initiated** does not require you to open inbound ports on the Amazon EC2 instance or Amazon WorkSpace, while **Bidirectional** and **Manager-Initiated** do.
 - **Agent/Appliance Initiated** is the safest option since no inbound ports need to be opened on the Amazon EC2 instance or Amazon WorkSpace.
3. If you're using Amazon WorkSpaces, and you chose to set the communication direction to **Bidirectional** or **Manager-Initiated**, [manually assign an elastic IP address to each WorkSpace](#) before proceeding with further steps on this page. This gives the WorkSpace a

public IP that can be contacted by the Deep Security Manager. This is not required for EC2 instances because they already use public IP addresses. WorkSpaces use private IP addresses.

Configure the activation type

'Activation' is the process of registering an agent with a manager. You'll need to indicate whether you'll allow agent-initiated activation. If not, only manager-initiated activation is allowed.

1. Log in to Deep Security Manager.
2. Click **Administration** at the top.
3. On the left, click **System Settings**.
4. In the main pane, make sure the **Agents** tab is selected.
5. Select or deselect **Allow Agent-Initiated Activation**, noting that:
 - Agent-initiated activation does not require you to open up inbound ports to your Amazon EC2 instances or Amazon WorkSpaces, while manager-initiated activation does.
 - If agent-initiated activation is enabled, manager-initiated activation continues to work.
 - Agent-initiated activation works even if you set the communication direction to **Manager-Initiated**.
6. If you selected **Allow Agent-Initiated Activation**, also select **Reactivate cloned Agents**, and **Enable Reactivate unknown Agents**. See "[Agent settings](#)" on page 1474 for more information.
7. Click **Save**.
8. If you're using Amazon WorkSpaces, and you *didn't* allow agent-initiated activation, [manually assign an elastic IP address to each Workspace now](#), before proceeding with further steps on this page. This gives each Amazon Workspace a public IP that can be contacted by other computers. This is not required for EC2 instances because they already

use public IP addresses.

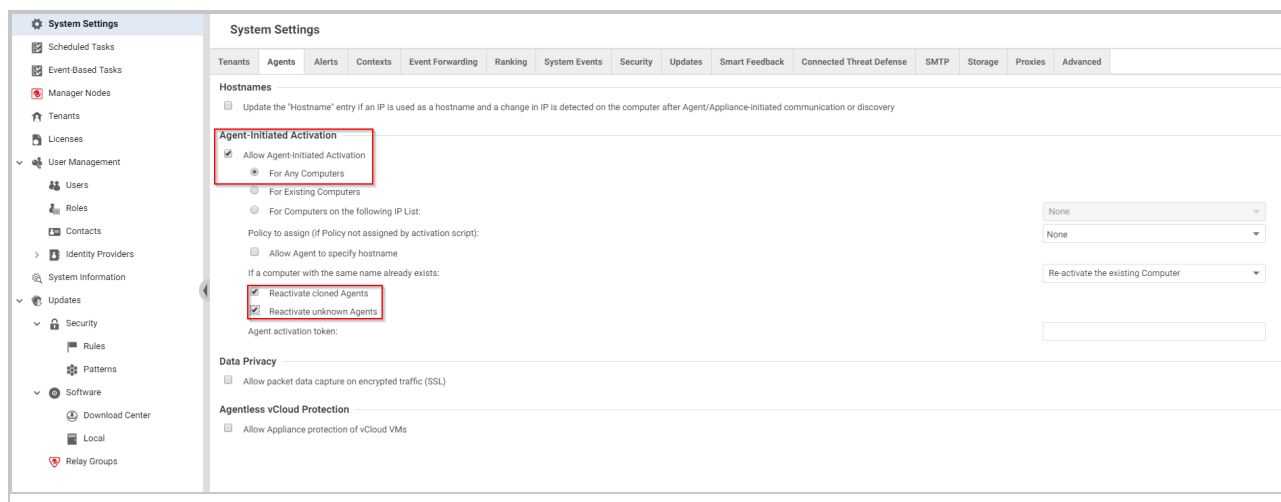

Open ports

You'll need to make sure that the necessary ports are open to your Amazon EC2 instances or Amazon WorkSpaces.

To open ports:

1. Open ports to your Amazon EC2 instances, as follows:
 - a. Log in to your [Amazon Web Services Console](#).
 - b. Go to **EC2 > Network & Security > Security Groups**.
 - c. Select the security group that is associated with your EC2 instances, then select **Actions > Edit outbound rules**.
 - d. Open the necessary ports. See "[Which ports should be opened?](#)" below below.
2. Open ports to your Amazon WorkSpaces, as follows:
 - a. Go to the firewall software that is protecting your Amazon WorkSpaces, and open the ports listed above.

You have now opened the necessary ports so that Deep Security Agent and Deep Security Manager can communicate.

Which ports should be opened?

Generally-speaking:

- agent-to-manager communication requires you to open the outbound TCP port (443 or 80, by default)

- manager-to-agent communication requires you to open an inbound TCP port (4118).

More specifically:

- If you set the communication direction to **Agent/Appliance-Initiated**, you'll need to open the *outbound* TCP port (443 or 80, by default).
- If you set the communication direction to **Manager-Initiated**, you'll need to open the *inbound* TCP port of 4118.
- If you set the communication direction to **Bidirectional**, you'll need to open both the *outbound* TCP port (443 or 80, by default) AND the *inbound* TCP port of 4118.
- If you enabled **Allow Agent-Initiated Activation**, you'll need to open the *outbound* TCP port (443 or 80, by default) regardless of how you set the communication direction.
- If you disabled **Allow Agent-Initiated Activation**, you'll need to open the *inbound* TCP port of 4118 regardless of how you set the communication direction.

Deploy agents to your Amazon EC2 instances and WorkSpaces

You'll need to deploy agents onto your Amazon EC2 instances and Amazon WorkSpaces. Below are a couple of options.

- **Option 1: Use a deployment script to install, activate, and assign a policy**

Use Option 1 if you need to deploy agents to many Amazon EC2 instances and Amazon WorkSpaces.

With this option, you must run a deployment script on the Amazon EC2 instances or Amazon WorkSpaces. The script installs and activates the agent and then assigns a policy. See "[Use deployment scripts to add and protect computers](#)" on page 1790 for details.

OR

- **Option 2: Manually install and activate**

Use Option 2 if you only need to deploy agents to a few EC2 instances and Amazon WorkSpaces.

- a. Get the Deep Security Agent software, copy it to the Amazon EC2 instance or Amazon WorkSpace, and then install it. For details, see "[Get Deep Security Agent software](#)" on page 497, and "[Install the agent](#)" on page 515.

- b. Activate the agent. You can do so on the agent (if agent-initiated activation was enabled) or on the Deep Security Manager. For details, see ["Activate the agent" on page 538](#)

You have now installed and activated Deep Security Agent on an Amazon EC2 instance or Amazon WorkSpace. A policy may or may not have been assigned, depending on the option you chose. If you chose Option 1 (you used a deployment script), a policy was assigned to the agent during activation. If you chose Option 2 (you manually installed and activated the agent), then no policy has been assigned, and you will need to assign one following the instructions further down on this page.

Verify that the agent was installed and activated properly

You should verify that your agent was installed and activated properly.

1. Log in to Deep Security Manager.
2. Click **Computers** at the top.
3. On the navigation pane on the left, make sure your Amazon EC2 instance or Amazon WorkSpace appears under **Computers** > *your_AWS_account* > *your_region* . (Look for WorkSpaces in a **WorkSpaces** sub-node.)
4. In the main pane, make sure your Amazon EC2 instances or Amazon WorkSpaces appear with a **Status of Managed (Online)** and a green dot next to them.

Assign a policy

Skip this step if you ran a deployment script to install and activate the agent. The script already assigned a policy so no further action is required.

If you installed and activated the agent manually, you must assign a policy to the agent. Assigning the policy sends the necessary protection modules to the agent so that your computer is protected.

To assign a policy, see ["Assign a policy to a computer" on page 699](#).

After assigning a policy, your Amazon EC2 instance or Amazon WorkSpace is now protected.

Install the agent on an AMI or WorkSpace bundle

Read this page if you want to launch *new* Amazon EC2 instances and Amazon WorkSpaces with the agent 'baked in'.

If instead you want to:

- protect *existing* Amazon EC2 instances and Amazon WorkSpaces with Deep Security, see ["Install the agent on Amazon EC2 and WorkSpaces" on page 522](#).
- protect Amazon WorkSpaces after already protecting your Amazon EC2 instances, see instead ["Protect Amazon WorkSpaces if you already added your AWS account" on page 654](#).

'Baking the agent' is the process of launching an EC2 instance based on a public AMI, installing the agent on it, and then saving this custom EC2 image as an AMI. This AMI (with the agent 'baked in') can then be selected when launching new Amazon EC2 instances.

Similarly, if you want to deploy the Deep Security Agent on multiple Amazon WorkSpaces, you can create a custom 'WorkSpace bundle' that includes the agent. The custom bundle can then be selected when launching new Amazon WorkSpaces.

To bake an AMI and create a custom WorkSpace bundle with a pre-installed and pre-activated agent, follow these steps:

1. ["Add your AWS account to Deep Security Manager" below](#)
2. ["Set the communication direction" on the next page](#)
3. ["Configure the activation type" on the next page](#)
4. ["Launch a 'master' Amazon EC2 instance or Amazon WorkSpace" on the next page](#)
5. ["Deploy an agent on the master" on the next page](#)
6. ["Verify that the agent was installed and activated properly" on page 530](#)
7. ["\(Recommended\) Set up policy auto-assignment" on page 530](#)
8. ["Create an AMI or custom WorkSpace bundle based on the master" on page 531](#)
9. ["Use the AMI" on page 531](#)

Add your AWS account to Deep Security Manager

You'll need to add your AWS accounts to Deep Security Manager. These are the AWS accounts that will contain the Amazon EC2 instances and Amazon WorkSpaces that you want to protect.

See ["About adding AWS accounts" on page 640](#) for details.

Set the communication direction

You'll need to set the communication direction: either agent-initiated, manager-initiated, or bidirectional.

See "[Install the agent on Amazon EC2 and WorkSpaces](#)" on page 522 > "[Set the communication direction](#)" on page 523 for instructions.

Configure the activation type

You'll need to indicate whether you'll allow agent-initiated activation.

See "[Install the agent on Amazon EC2 and WorkSpaces](#)" on page 522 > "[Configure the activation type](#)" on page 524 for instructions.

Launch a 'master' Amazon EC2 instance or Amazon WorkSpace

You'll need to launch a 'master' Amazon EC2 instance or Amazon WorkSpace. The master instance is the basis for the EC2 AMI or WorkSpace bundle that you will create later.

1. In AWS, launch an Amazon EC2 instance or Amazon WorkSpace. See the [Amazon EC2 documentation](#) and [Amazon WorkSpaces documentation](#) for details.
2. Call the instance 'master'.

Deploy an agent on the master

You'll need to install and activate the agent on the master. During this process, you can optionally install a policy.

See "[Install the agent on Amazon EC2 and WorkSpaces](#)" on page 522 > "[Deploy agents to your Amazon EC2 instances and WorkSpaces](#)" on page 526 for instructions.

Tip: Ideally, if you bake the agent into your AMI or workspace bundle and then want to use a newer agent later on, you should update the bundle to include the new agent. However, if that's not possible, you can use the **Automatically upgrade agents on activation** setting so when the agent in the AMI or bundle activates itself, Deep Security Manager can automatically upgrade the agent to the latest version. For details, see "[Automatically upgrade agents on activation](#)" on page 1462.

Verify that the agent was installed and activated properly

You should verify that the agent was installed and activated properly on the master before proceeding.

See ["Install the agent on Amazon EC2 and WorkSpaces" on page 522](#) > ["Verify that the agent was installed and activated properly" on page 527](#) for instructions.

(Recommended) Set up policy auto-assignment

You may need to set up policy auto-assignment depending on how you deployed the agent on the master:

- If you used a deployment script, then a policy has already been assigned, and no further action is required.
- If you manually installed and activated the agent, no policy was assigned to the agent, and one should be assigned now so that the master is protected. The Amazon EC2 instances and Amazon WorkSpaces that are launched based on the master will also be protected.

If you want to assign a policy to the master, as well as auto-assign a policy to future EC2 instances and WorkSpaces that are launched using the master, follow these instructions:

1. In Deep Security Manager, create an event-based task with these parameters:
 - Set the **Event** to **Agent-Initiated Activation**.
 - Set **Assign Policy** to the policy you want to assign.
 - (Optional) Set a condition to **Cloud Instance Metadata**, with
 - a **tagKey** of **EC2** and a **tagValue.*** of **True** (for an EC2 instance)
OR
 - a **tagKey** of **WorkSpaces** and a **tagValue.*** of **True** (for WorkSpaces)

The above event-based task says:

When an agent is activated, assign the specified policy, on condition that `EC2=true` or `WorkSpaces=true` exists in the Amazon EC2 instance or WorkSpace.

If that key/value pair does not exist in the EC2 instance or WorkSpace, then the policy is not assigned (but the agent is still activated). If you do not specify a condition, then the policy is assigned on activation unconditionally.

For details on creating event-based tasks, see ["Automatically assign policies using cloud provider tags/labels" on page 1802](#).

2. If you added a key/value pair in Deep Security Manager in the previous step, do the following:
 - a. Go to AWS.
 - b. Find your master EC2 instance or Workspace.
 - c. Add tags to the master with a **Key** of **EC2** or **WorkSpaces** and a **Value** of **True**. For details, see this [Amazon EC2 documentation on tagging](#), and this [Amazon Workspace documentation on tagging](#).
You have now set up policy auto-assignment. New Amazon EC2 instances and Amazon WorkSpaces that are launched using the master are activated automatically (since the agent is pre-activated on the master), and then auto-assigned a policy through the event-based task.
3. On the master EC2 instance or Workspace, reactivate the agent by re-running the activation command on the agent, or by clicking the **Reactivate** button in Deep Security Manager. For details, see ["Activate the agent" on page 538](#)
The re-activation causes the event-based task to assign the policy to the master. The master is now protected.

You are now ready to bake your AMI or create a custom Workspace bundle.

Create an AMI or custom Workspace bundle based on the master

Note: When creating an AMI from AWS, do not select the AWS option **No reboot**. Images created with the **No reboot** option will not be protected by the agent.

- To create an AMI on Linux, see [this Amazon documentation](#).
- To create an AMI on Windows, see [this Amazon documentation](#).
- To create a custom Workspace bundle, see [this Amazon documentation](#).

You now have an AMI or Workspace bundle that includes a pre-installed and pre-activated agent.

Use the AMI

Now that you have a custom AMI or Workspace bundle, you can use it as the basis for future Amazon EC2 instances and Amazon WorkSpaces. With the custom AMI or bundle, Deep

Security Agent starts up automatically, activates itself, and applies the protection policy assigned to it. It appears in Deep Security Manager with a **Status of Managed** and a green dot next to it.

Install the agent on Azure VMs

To install the agent on VM instances running in the Microsoft Azure cloud, you need to deploy Deep Security Agents to them. You can do this in multiple ways:

- You can generate Deep Security deployment scripts for automatically deploying agents using deployment tools such as RightScale, Chef, Puppet, and SSH. For more information on how to do so, see ["Use deployment scripts to add and protect computers" on page 1790](#).
- You can add a custom script extension to an existing virtual machine to deploy and activate the Deep Security Agent. To do this, navigate to your existing virtual machine in the Azure management portal and follow the steps below to upload and execute the deployment script on your Azure VM.

To add a custom script extension to an existing virtual machine:

1. Log in to the Azure portal.
2. Switch to the preview portal, and then click the virtual machine that you want to add the custom script to.
3. In the **Settings** blade, click **Extensions**, in the **Extensions** blade, click **Add extension**, in the **New Resource** blade, select **Custom Script**, and then click **Create**.
4. In the **Add Extension** blade under **Script File (required)**, click **upload**, select the saved .ps1 deployment script, and then click **OK**.

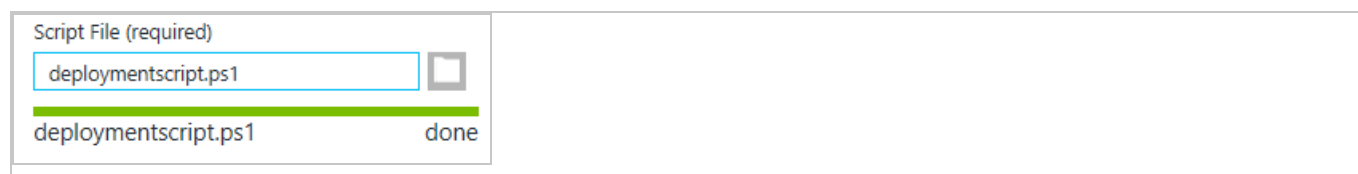

Install the agent on Google Cloud Platform VMs

Read this page if you want to protect existing Google Cloud Platform (GCP) VM instances with Deep Security.

To protect your existing GCP VMs:

1. Add a GCP service account to Deep Security Manager. For instructions, see ["Add a Google Cloud Platform account" on page 677](#).
2. Set the communication direction to **Agent/Appliance Initiated**. For instructions, see ["Configure communication directionality" on page 1450](#).
3. Configure agent-initiated activation (AIA). For instructions, see ["Activate and protect agents using agent-initiated activation and communication" on page 1460](#).
4. Open ports so that Deep Security components can access your GCP VMs and the GCP API. For information on which ports to open, see ["Port numbers, URLs, and IP addresses" on page 410](#). For instructions on how to open ports, see [this GCP webpage](#).
5. Deploy agents to your GCP VMs. You must use Deep Security Agent *12 or later*.

To deploy agents, you have two options:

Option	Use if...	Instructions
<p>Option 1:</p> <p>Use a deployment script to install, activate, and assign a policy to the agent</p>	<p>You need to deploy many agents to your GCP VMs.</p>	<p>See "Use deployment scripts to add and protect computers" on page 1790 for instructions.</p>
<p>Option 2:</p> <p>Manually install and activate the agent</p>	<p>You only need to deploy a few agents.</p>	<p>a. Obtain the Deep Security Agent software, copy it to the GCP VM, and then install it. For details, see "Get Deep Security Agent"</p>

Option	Use if...	Instructions
		<p>software" on page 497</p> <p>b. Activate the agent. You can do so on the agent or on the Deep Security Manager. For details, see "Activate the agent" on page 538</p>

6. Verify that the agent was installed and activated properly:
 - a. Log in to Deep Security Manager.
 - b. Click **Computers** at the top.
 - c. On the navigation pane on the left, make sure your GCP VM appears under **Computers** > *your_GCP_service_account* > *your_GCP_project*.
 - d. In the main pane, make sure your GCP VMs appear with a **Status of Managed (Online)** and a green dot next to them.
7. Assign a policy if you installed and activated the agent manually. For instructions, see ["Assign a policy to a computer" on page 699](#). Assigning the policy sends the necessary protection modules to the agent so that your computer is protected.

Note: Skip the policy assignment step if you ran a deployment script to install and activate the agent. The script already assigned a policy so no further action is required.

After assigning a policy, your GCP VM is now protected.

Install the agent on VMware vCloud

To enable vCloud integration, you must assign a minimum set of rights to the user accounts tenants will use to import their vCloud "Cloud Accounts" and you must configure the vCenter database to assign unique UUIDs to new virtual machines.

Note: To deploy Deep Security protection agentlessly in a vCloud environment, see instead ["Deploy the appliance in a vCloud environment" on page 612](#).

Create a minimum rights role for vCloud account tenant users

The user accounts you create in vCloud Director that the Deep Security tenants will use to add their cloud accounts to their Deep Security Manager require only the **All Rights > General > Administrator View** right.

1. Log in to vCloud Director.
2. In the **System** tab, click on **Administration**.
3. In the navigation panel on the left, click on **Roles**.
4. Click the "plus" sign to create a new Role (for example, "DS_User").
5. Select the **Administrator View** right in the **All Rights > General** folder.
6. Click **OK**.

You can now assign this role to the user accounts you will give to Deep Security users to import their vCloud resources into the Deep Security Manager.

Note: When providing a Deep Security user with their credentials, you must include the IP address of the vCloud Organization and instruct them that when importing the vCloud resources into their Deep Security Manager, their username must include "@orgName". For example if the vCloud account's username is **kevin** and the vCloud Organization you've given the account access to is called **CloudOrgOne**, then the Deep Security user must enter **kevin@CloudOrgOne** as their username when importing the vCloud resources. (For a vCloud administrator view, use **@system**.)

Note: You can configure Deep Security Manager to use a proxy server specifically for connecting to instances being protected in Cloud Accounts. The proxy setting can be found in **Administration > System Settings > Proxies > Proxy Server Use > Deep Security Manager (Cloud Accounts)**.

Assign unique UUIDs to new virtual machines

Deep Security requires that all protected virtual machines have unique UUIDs. Virtual machines created from a vApp template can be assigned duplicate UUIDs which can cause problems. To configure your vCloud database to assign unique UUIDs, set the `CloneBiosUuidOnVmCopy` property to zero (0) following [VMware Knowledge Base article 2002506](#).

Enable the OVF Environment Transport for VMware Tools on your guest VMs

Enabling the OVF Environment Transport for VMware Tools on your guest VMs will expose the `guestInfo.ovfEnv` environment variable making it easier for Agents to uniquely identify their VMs to the Deep Security Manager. This will reduce the risk of VM misidentification.

1. In vCloud Director, open the VM's **Properties** screen, go the **Guest OS Customization** tab and select the **Enable guest customization** checkbox. Click **OK**.
2. In vCenter, select the same VM, open its **Properties** screen, go to the **Options** tab.
3. Click **vApp Options** and select the **Enabled** radio button. **OVF Settings** will now be exposed.
4. In **OVF Settings**, select the **VMware Tools** checkbox in the **OVF Environment Transport** area. Click **OK**.

If your VM is running, it must be restarted for the changes to take effect.

The data used by Deep Security are taken from the following properties:

`vmware.guestinfo.ovfenv.vcenterid` and `vmware.guestinfo.ovfenv.vcloud.computername`.

Import computers from a VMware vCloud Organization account

Note: vCloud Organization accounts must be added by tenants (not the primary tenant).

1. In the Deep Security Manager, go to the **Computers** section, right-click **Computers** in the navigation panel and select **Add vCloud Account** to display the **Add vCloud Account** wizard.
2. Enter a **Name** and **Description** of the resources you are adding. (These are only used for display purposes in the Deep Security Manager.)
3. Enter the vCloud **Address**. (The hostname of the vCloud Director host machine.)

4. Enter your **User name** and **Password**.

Note: Your **User name** must be in the form `username@vcloudorganization`.

5. Click **Next**.
6. Deep Security Manager will verify the connection to the cloud resources and display a summary of the import action. Click **Finish**.

The VMware vCloud resources now appear in the Deep Security Manager under their own branch under **Computers** in the navigation panel.

After adding the Cloud Provider resources, you must install an agent, activate the agent, and assign a policy to the computer (see "[Install the agent](#)" on page 515 or "[Use deployment scripts to add and protect computers](#)" on page 1790, and "[Activate the agent](#)" on the next page.)

Import computers from a VMware vCloud Air Virtual data center

1. In the Deep Security Manager, go to the **Computers** section, right-click **Computers** in the navigation panel and select **Add vCloud Account** to display the **Add vCloud Account** wizard.
2. Enter a **Name** and **Description** of the VMware vCloud Air virtual data center you are adding. (These are only used for display purposes in the Deep Security Manager.)
3. Enter the **Address** of the VMware vCloud Air virtual data center.

Note: To determine the address of the VMware vCloud Air virtual data center:

- a. Log in to your VMware vCloud Air portal.
- b. On the **Dashboard** tab, click on the data center you want to import into Deep Security. This will display the **Virtual Data Center Details** information page.
- c. In the Related Links section of the **Virtual Data Center Details** page, click on **vCloud Director API URL**. This will display the full URL of the vCloud Director API.
- d. Use the hostname only (not the full URL) as the Address of the VMware vCloud Air virtual data center that you are importing into Deep Security.

4. Enter your **User name** and **Password**.

Note: Your **User name** must be in the form `username@virtualdatacenterid`.

5. Click **Next**.
6. Deep Security Manager will verify the connection to the virtual data center and display a summary of the import action. Click **Finish**.

The VMware vCloud Air data center now appears in the Deep Security Manager under its own branch under **Computers** in the navigation panel.

After adding the Cloud Provider resources, you must install an agent, activate the agent, and assign a policy to the computer (see ["Install the agent" on page 515](#) or ["Use deployment scripts to add and protect computers" on page 1790](#) and ["Activate the agent" below](#).)

Activate the agent

Tip: If you haven't already installed the agent, see ["Use deployment scripts to add and protect computers" on page 1790](#) or ["Install the agent" on page 515](#) for instructions.

Before the installed agent can protect its computer or be converted to a relay, you must activate the agent with Deep Security Manager. Activation registers the agent with the manager during an initial communication.

To do this, you can either:

- Activate the agent from the manager. Go to **Computers**, right-click the computer whose agent or appliance you want to activate or reactivate and select **Actions > Activate/Reactivate**. (Alternatively, click **Activate** or **Reactivate** in the computer's **Details** window.)
- Activate the agent through a deployment script. See ["Use deployment scripts to add and protect computers" on page 1790](#) for details.
- Activate the agent from the computer where the agent is installed. Run this command:

```
dsa_control -a dsm://<dsm_host_or_IP>:<port>/
```

where:
`<dsm_host_or_IP>` is replaced with the Deep Security Manager hostname or IP address, and
`<port>` is replaced with the Deep Security Manager heartbeat port, which is 4120, by default.
For details on this command, including additional parameters, see ["Command-line basics" on page 1731](#).
- Activate the agent through an event-based task ("Computer Created (by System)" event) to automatically activate computers when they connect to the manager or when the manager syncs with an LDAP directory, cloud account, or vCenter. For more information, see ["Automatically perform tasks when a computer is added or changed \(event-based tasks\)" on page 1769](#).

Before activation, the agent or appliance will have one of these [statuses](#):

- **No Agent/Appliance:** Indicates one of the following situations:
 - No agent or appliance is running or listening on the default port.
 - An agent or appliance is installed and running but is working with another manager and communications are configured as agent/appliance-initiated. In this case, the agent or appliance is not listening for this manager. To correct this situation, deactivate the agent from the computer.
- **Activation Required:** The agent or appliance is installed and listening, and is ready to be activated by the manager.
- **Reactivation Required:** The agent or appliance is installed and listening and is waiting to be reactivated by the manager.
- **Deactivation Required:** The agent or appliance is installed and listening, but has already been activated by another manager.
- **Unknown:** The computer has been imported (as part of an imported Computers list) without state information, or has been added by way of an LDAP directory discovery process.

After a successful activation, the agent or appliance state is Online. If the activation failed, the computer status is Activation Failed with the reason for the failure in brackets. Click this link to display the system event for more details on the reason for the activation failure.

Note: Although IPv6 traffic is supported by Deep Security 8.0 and earlier agents and appliances, it is blocked by default. To allow IPv6 traffic on Deep Security 8.0 Agents and Appliances, open a **Computer or Policy editor**¹ and go to **Settings > Advanced > Advanced Network Engine Settings**. Set the **Block IPv6 for 8.0 and Above Agents and Appliances** option to **No**.

Deactivate the agent

If you want to transfer control of a computer from one Deep Security Manager installation to another, you must deactivate the agent or appliance with its current manager, and then re-activate it with the new manager.

You can normally deactivate the agent or appliance from the Deep Security Manager that is currently managing the agent or appliance. If the Deep Security Manager cannot communicate

¹You can change these settings for a policy or for a specific computer. To change the settings for a policy, go to the Policies page and double-click the policy that you want to edit (or select the policy and click Details). To change the settings for a computer, go to the Computers page and double-click the computer that you want to edit (or select the computer and click Details).

with the agent or appliance, you may have to perform the deactivation manually. To run the commands below, you must have administrator privileges on the local machine.

To deactivate the agent on Windows:

1. From a command line, change to the agent directory (Default is C:\Program Files\Trend Micro\Deep Security Agent)
2. Run the following: `dsa_control -r`

To deactivate the agent on Linux:

1. Run the following: `/opt/ds_agent/dsa_control -r`

Start or stop the agent

To start or stop the agent on Windows:

- Start: `sc start ds_agent`
- Stop: `sc stop ds_agent`

To start or stop the agent on Linux:

Using SysV init scripts:

- Start: `/etc/init.d/ds_agent start`
- Stop: `/etc/init.d/ds_agent stop`

Using systemd commands:

- Start: `systemctl start ds_agent`
- Stop: `systemctl stop ds_agent`

To start or stop the agent that is embedded on the Deep Security Virtual Appliance, see "[Start or stop the appliance](#)" on page 630.

Common issues when installing or updating the agent

This article looks at three of the most common issues that can occur when installing or updating agents.

General helpful links

<https://help.deepsecurity.trendmicro.com/aws/welcome.html>

<https://success.trendmicro.com/product-support/deep-security-20-0>

1. Anti-Malware engine offline (Windows)

This problem typically occurs on Windows machines, where the Anti-Malware module has either not installed properly, or a driver/service is not running. From the Agent side, the Deep Security notifier app in the taskbar will show a status of “Driver Offline/Not Installed.” If the server reporting this error has not had the initial root certificate updates installed from Microsoft’s Updates, then the server must be patched, the Agent must be uninstalled, the server rebooted, and the Agent re-installed/re-activated.

Most of the time this problem is resolved by uninstalling, restarting, and re-installing/re-activating the Agent, as the troubleshooting steps in the first article referenced below states.

For a full walkthrough of cleaning up the Deep Security Agent from a Windows machine, refer to the third article linked below, which includes instructions for manually uninstalling the Deep Security Agent. It’s not always necessary to manually uninstall the Agent, but the instructions include file locations, registry entries, and services to clean up, after a normal uninstall and reboot has been completed.

Helpful links:

<https://success.trendmicro.com/solution/1104241-updating-the-verisign-and-digicert-certificate-on-deep-security>

<https://help.deepsecurity.trendmicro.com/aws/anti-malware-event-engine-offline.html>

<https://success.trendmicro.com/solution/1096150-manually-uninstalling-deep-security-agent-relay-and-notifier-from-windows>

2. Security update failed

If a Deep Security Agent is unable to communicate with the designated Deep Security Relay in the environment, the server has a risk of not running the latest Anti-Malware patterns, so this can be a higher priority issue.

When troubleshooting security update failures, the most common reason for the failure is due to network connectivity between the Deep Security Agent and the Deep Security Relay. The article linked below gives a few steps for checking that connectivity and confirming TCP communication is functioning between the two components.

Using a utility like Test-NetConnection in Powershell, or telnet/curl from a Linux server can help with confirming TCP communication between the Agent and Manager are open. If TCP connectivity is open, then there could potentially be a device between the two that is performing SSL Inspection, or interfering with the encrypted connection between the two points.

The ds_agent.log file on the Agent will normally provide a reason for why it cannot perform a security update and will be identified at the start of the line with the word Error or Warning. Correlate the update attempt time with the time in the log file to identify the underlying reason why updates are failing.

Log file location:

- Windows - `C:\ProgramData\Trend Micro\Deep Security Agent\diag`
- Linux - `/var/opt/ds_agent/diag`

Helpful links:

<https://help.deepsecurity.trendmicro.com/aws/security-update-connectivity.html>

https://www.trendmicro.com/en_us/business/products/downloads.html

3. Performance/Application issues introduced after installing the Deep Security Agent (Anti-Malware and Module Isolation)

Prior to deploying a Deep Security Agent, the appropriate security configuration will need to be applied to a server; this is common with any Anti-Malware/Security software, and ensures the server or applications installed are not negatively impacted by increased review of their activity.

Although this section does not refer directly to a status in the Deep Security console, this is one of the more common configuration adjustments that will require troubleshooting after deploying the Deep Security Agent to a new server. If a server's performance is impacted, or an application's functionality is impacted, you should first identify which Deep Security module could be contributing to the problem.

Performance issues can be identified first by which processes on a server may be utilizing more CPU/RAM than others. In Windows machines, there are two services that could typically be the culprit; dsa.exe or coreServiceShell.exe. dsa.exe is the core Agent process running on the machine, and coreServiceShell.exe is part of the Anti-Malware module. In a Linux server, these processes are named ds_agent and ds_am, respectively.

Regardless of which process is consuming resources, you'll want to narrow down which protection module(s) are contributing to the increased use of resources. By turning off individual modules, one-by-one, from the Deep Security Manager console, you can watch the resource utilization for any decrease in use, then likely attribute that behavior to the most recent module disabled.

When `coreServiceShell.exe` or `ds_am` processes are utilizing a high amount of CPU, this is usually indicative of the Real-Time Anti-Malware engine scanning a high number of read/write transactions on the server, requiring a higher amount of resources to complete its job.

This high amount of activity can be reduced by adding exclusions for data/applications we know are safe. The most common method for reducing resource utilization, or resolving other Application issues introduced from the Anti-Malware module, is by identifying safe applications running on the server, and implementing Process Image exclusions. A Process Image exclusion is a pointer to the full path of a process running on the server that you know to be safe, such as `sqlsvr.exe` for Microsoft SQL Server. By excluding this process, any files accessed by the `sqlsvr.exe` process would not be scanned by the Real-Time engine. To make these adjustments, the Scan Configuration for the machine/policy must be edited in the Deep Security Manager, to include the appropriate processes to be excluded.

Applications that are impacted by the Anti-Malware module may require additional troubleshooting after applying exclusions, including collecting additional information from the server. On the server encountering Anti-Malware related application issues, additional debug logging can be enabled by editing the `C:\Program Files\Trend Micro\AMSP\AmspConfig.ini` file; change the line `DebugLevel=0` to `DebugLevel=1` or `2` (2 logs further information). Restart the Trend Micro Deep Security Agent and Solution Platform services for those changes to take effect. To revert these logging options, adjust the `DebugLevel` back to `0`, and perform the same service restarts.

On Linux servers, Identify the PID for `ds_am` process:

```
$ ps aux | grep ds_am
```

Increase debug level (run command multiple times to increase level by 1):

```
kill -USR1 $(PID_for_ds_am)
```

To decrease the debug level (run command multiple times to decrease level by 1):

```
kill -USR2 $(PID_for_ds_am)
```

Reproduce the problem, and then collect a diagnostic package from the command line (link), which will include the additional information from the logging level that was adjusted (note:

collecting the Diagnostic Package from the Deep Security Manager will include additional information not collected via command line). This diagnostic package can be provided to the support team to review and help identify the underlying problem.

Helpful links:

<https://help.deepsecurity.trendmicro.com/aws/high-cpu-usage.html>

Deploy Deep Security Virtual Appliance

Protection for VMware environments

The Deep Security Virtual Appliance will reach [end of extended support \(EOL\)](#) on 31-Dec-2027 or VMware's end of support date for NSX-4.X, whichever comes first.

Trend Micro Deep Security has worked closely with VMware to offer agentless security at the hypervisor level. This security is provided by the Deep Security Virtual Appliance. The appliance is deployed at the cluster level through NSX Manager to offer protection to VMs on the same ESXi host.

Topics on this page:

- ["Deep Security Virtual Appliance features" below](#)
- ["VMware deployments with the virtual appliance and NSX" on the next page](#)
- ["VMware deployments with the agent only" on page 547](#)
- ["Additional information" on page 547](#)

Deep Security Virtual Appliance features

Scan caching

The scan cache allows the results of an Anti-Malware scan to be used when scanning multiple machines with the same files. When the appliance scans the original guest virtual machine, it keeps track of attributes of the files it is scanning. When other virtual machines are scanned, it can compare these attributes for each file. This means that subsequent files with the same attributes do not need to be scanned fully a second time, which reduces the overall scan time. In situations like virtual desktop infrastructure (VDI) where the images are nearly identical, the performance savings from scan cache are greater.

Scan storm optimization

A 'scan storm' occurs where many scans occur concurrently, causing performance slowdowns. Typically, scan storms occur in large-scale VDI deployments. When performing Anti-Malware scanning, the appliance can use the [scan cache](#) feature to optimize its resource usage during a scan storm.

Ease of management

Generally, deploying one Deep Security Virtual Appliance to each ESXi host is easier than deploying a Deep Security Agent on multiple VMs. With NSX, this management savings increases because NSX Manager automatically deploys Deep Security the service when you add a new ESXi host to the cluster.

The virtual appliance can also help with network flexibility. Each Deep Security Agent requires network connectivity to resolve the Deep Security Manager and Relay. By using the Deep Security Virtual Appliance, this network connectivity is limited to the virtual appliance and connectivity to each VM is not required.

In some cases, the infrastructure and VMs may be managed by different teams. By using the virtual appliance, the infrastructure team does not require access to the virtual machine to add protection because it can be deployed at the hypervisor level to protect each of the virtual machines.

VMware deployments with the virtual appliance and NSX

If you want to use the Deep Security Virtual Appliance to protect your guest VMs, you'll need to use VMware NSX Data Center for vSphere (NSX-V) or NSX-T Data Center. NSX-V and NSX-T have several license types. These license types are shown in the table below, along with the Deep Security features supported by each.

Note: For a more detailed list of supported features and sub-features that are supported by the Deep Security Virtual Appliance, see "[Deep Security Virtual Appliance 20 \(NSX\) supported guest operating systems](#)" on page 395.

Deep Security Virtual Appliance deployment								
	NSX for vSphere (NSX-V) 6.4.x			NSX for vSphere (NSX-V) 6.4.x and NSX-T 3.x				
	Standard Or NSX for vShield Endpoint (free)	Advanced	Enterprise	Standard Or NSX for vShield Endpoint (free)	NSX Data Center Professional	NSX Data Center Advanced	NSX Data Center Enterprise Plus	NSX Data Center for Remote Office Branch Office
Anti-Malware	✓ ¹	✓ ¹	✓ ¹	✓ ¹	✓ ¹	✓ ¹	✓ ¹	✓ ¹
Integrity Monitoring	✓ ¹	✓ ¹	✓ ¹	✓ ¹	✓ ¹	✓ ¹	✓ ¹	✓ ¹
Firewall	X	✓	✓	X	X	✓	✓	✓
Intrusion Prevention	X	✓	✓	X	X	✓	✓	✓
Web Reputation	X	✓	✓	X	X	✓	✓	✓
Log Inspection	X	X	X	X	X	X	X	X
Application Control	X	X	X	X	X	X	X	X

¹ Available on Windows guest VMs only

If a feature is not supported by the appliance (X), it can be procured through the agent. When you install agents to supplement the virtual appliance's functionality, this is known as [combined mode](#).

Some key points when considering combined mode:

- Management: Deep Security has deployment scripts that can be used to script the deployment of the Deep Security Agent using various orchestration tools (Chef, Puppet, etc). Using the [deployment scripts](#) allows for easier deployment of the agent. These scripts also allow activation and assignment of policy. They help to reduce the manual intervention required and reduce the management cost when deploying the agent in a VMware environment.
- "[Scan caching](#)" on [page 544](#) performance improvements and "[Scan storm optimization](#)" on [page 545](#): In combined mode, the virtual appliance will do scan caching and scan storm optimization for Anti-Malware scanning. This allows the agent footprint on each VM to remain small because only a network driver needs to be installed.

For details on how to set up the Deep Security Virtual Appliance environment, see "[Deploy the appliance \(NSX-T 3.x\)](#)" on [page 554](#), or "[Deploy the appliance \(NSX-V\)](#)" on [page 589](#)

VMware deployments with the agent only

If you want to protect VMware environments without the virtual appliance or NSX, you can do so by deploying the Deep Security Agent to each of your VMs. In this scenario, you don't need the Deep Security Virtual Appliance, since all protection is provided by the agents. By using the Deep Security Agent, you get all of main features of Deep Security, namely: [Anti-Malware](#), [Integrity Monitoring](#), [Firewall](#), [Intrusion Prevention](#), [Web Reputation](#), [Log Inspection](#), and [Application Control](#). In addition, the agent has the following characteristics:

- It is lightweight (a Smart Agent). Only the protection modules that you specify (for example, Anti-Malware and Integrity Monitoring) are installed using a policy that you set up on the manager. Further, Deep Security has a feature called 'recommendation scanning', which allows you to only assign rules necessary for the specific workload you are protecting.
- Windows agents include an Anti-Malware scan cache, containing hashes of previously-scanned files that are frequently accessed, so that they don't need to be rescanned.

To deploy agents, Trend Micro has provided [deployment scripts](#) that can be used with various orchestration tools (Chef, Puppet, etc). You can also [install the agent manually](#).

Additional information

- Trend Micro and VMware Website: <https://www.trendmicro.com/VMware/>

Choose agentless vs. combined mode protection

If you are protecting virtual machines (VMs) you can install Deep Security Agent, just as you would for other types of computers. But in Deep Security 9.6 or later, there are two other ways to protect VMs:

- Agentlessly (via virtual appliance), or
- Mixture of agent-based and agentless ("combined mode")

Agentless protection

Anti-malware and Integrity Monitoring protection can be provided *without* installing Deep Security Agent. Instead, the VMware Tools driver installed on the VM can offload security processing to a Deep Security Virtual Appliance.

Note: On Linux VMs, Deep Security Agent provides anti-malware protection, not the Deep Security Virtual Appliance.

Note: In Deep Security 9.5 or earlier, to protect VMs without installing a Deep Security Agent, you would use the Deep Security Virtual Appliance and filter driver. The filter driver was installed on the ESXi server and was used to intercept network traffic at the hypervisor, and send it to the appliance. **VMware does not support vShield (VMsafe-NET API driver) anymore, so the old driver is not supported by Deep Security 20, and must be removed.**

Because agentless protection requires fast connectivity between the appliance and the computer you want to protect, don't use agentless if the computer is far from the appliance, on a remote ESXi server or another data center.

See also "[Deploy the appliance in a vCloud environment](#)" on page 612.

Combined mode

If you require other protection features that Deep Security Virtual Appliance doesn't support, you must install the Deep Security Agent on each of your VMs, but you can still use the Deep Security Virtual Appliance to provide some of the protection, which can improve performance. Both the appliance and agent used together is known as "combined mode".

With combined mode, the appliance provides the anti-malware and integrity monitoring. The Deep Security Agent provides other features.

Conversion of coordinated approach to combined mode

- **Coordinated approach** – In Deep Security 9.5, if the agent on a VM was offline, protection features would be provided by the Deep Security Virtual Appliance instead as an alternative. However, it could *not* be configured separately for each feature.
- **Combined mode** – In Deep Security 9.6, each protection feature was configurable to use either the agent or appliance. However, if the preferred protection source was offline, the computer *didn't* use the other alternative.

In Deep Security 10.0 and later, its "protection source" settings provide *both* behaviors:

- whether each feature is provided by the agent or appliance
- whether to use the agent or appliance alternative if the preferred protection is not available

So if you need behavior like the old coordinated approach, you might want to avoid upgrading to Deep Security 9.6, and instead upgrade from Deep Security 9.5 to Deep Security 10.0 and then to 12.

Choose an agent or appliance for each protection feature

If a computer could be protected by either an appliance or agent, you can select which will provide each protection feature.

Note: Log inspection and application control do not have this setting. With current VMware integration technologies, Deep Security Virtual Appliance cannot provide those features.

To configure the protection source, import a VMware vCenter into Deep Security Manager, then in the **Computer or Policy editor**¹, go to **Settings > General**.

¹You can change these settings for a policy or for a specific computer. To change the settings for a policy, go to the Policies page and double-click the policy that you want to edit (or select the policy and click Details). To change the settings for a computer, go to the Computers page and double-click the computer that you want to edit (or select the computer and click Details).

Protection Source when in Combined Mode

Select which component will provide protection when both the Agent and the Appliance are present.

Anti-Malware:	Inherited (Appliance preferred) ▼
Web Reputation / Firewall / Intrusion Prevention:	Inherited (Agent preferred) ▼
Integrity Monitoring:	Inherited (Appliance preferred) ▼

Protection Modules not shown here do not support Combined Mode configuration.

For each protection module or group of protection modules, select either:

- **Appliance Only:** Only the Deep Security Virtual Appliance will provide protection, even if there is an agent on the VM and the appliance is deactivated or removed.

Warning: Don't use the appliance if you require the scanner (SAP). It requires Deep Security Agent anti-malware.

Tip: When anti-malware is enabled on the agent, the agent downloads the Anti-malware Solution Platform (AMSP) and starts it as a service. If you do not want this, then from **Anti-Malware**, select **Appliance Only**. That way, even if the appliance is deactivated, the agent won't start the AMSP service.

- **Appliance Preferred:** If there is an activated appliance on the ESXi server, it will provide the protection. But if the appliance is deactivated or removed, then the agent will provide protection instead.
- **Agent Only:** Only the agent will provide protection, even if there is an activated appliance available.
- **Agent Preferred:** If there is an activated agent on the VM, it will provide the protection. But if there is no activated agent, then the appliance will provide protection instead.

Enable combined mode in a vCloud Director environment with agent-initiated activation

When the hostname of a vCloud Director virtual machine is not resolvable from Deep Security Manager, use agent-initiated activation to enable combined mode. To enable combined mode on a vCloud Director virtual machine:

1. Go to **Computers**, right-click on the target vCloud Director computer, and select **Activate**.
2. Double-click the target vCloud Director computer, and select **Settings > General** in the pop-up window. Change the **Communication Direction** to **Agent/Appliance Initiated**.

Communication Direction

Direction of Deep Security Manager to Agent/Appliance communication:

Agent/Appliance Initiated

3. Install Deep Security Agent on the target vCloud Director computer, and [activate the agent](#).

Before deploying the appliance

Before you deploy the Deep Security Virtual Appliance, complete the tasks below.

Note: If you want to upgrade the appliance, see instead "[Upgrade Deep Security Virtual Appliance](#)" on page 1633

Review system requirements

- Review [this table](#) to see which NSX licenses and versions are supported.
- Review these [system requirements](#).

Install or upgrade NSX, Deep Security Manager and other components

After reviewing the [system requirements](#), do the following:

- Install or upgrade NSX and make sure you're using a license that supports the features you want.
- Install or upgrade Deep Security Manager.
- Install or upgrade other required software and hardware.

Re-register NSX-T

Read this section if you previously added NSX-T to Deep Security Manager using the instructions in "[Add a VMware vCenter](#)" on page 681.

You may need to re-register NSX-T.

To check whether NSX-T needs to be re-registered:

1. Go to NSX-T Manager and click **System > Service Deployments > CATALOG**.
2. Make sure both **Endpoint Protection Policy** and **Intrusion Detection and Prevention Systems** are present, as shown in the image below. If not, it means a re-registration is required.

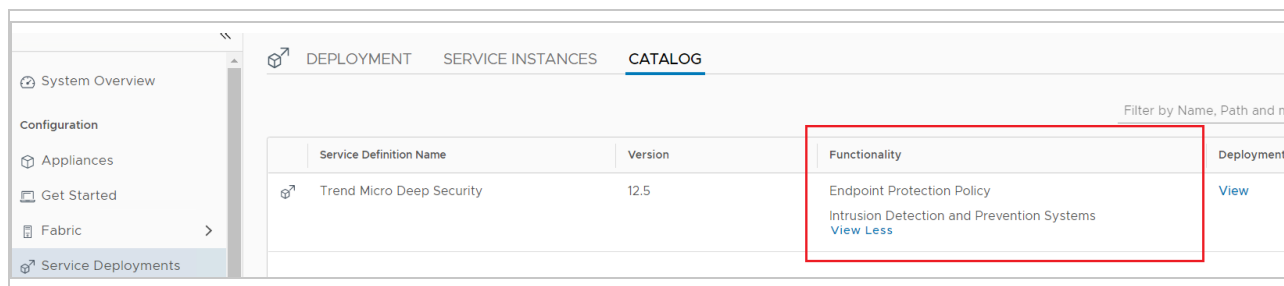

To re-register NSX-T:

1. Uninstall Deep Security from your NSX environment. See ["Uninstall Deep Security from your NSX environment" on page 1679](#) for details.
2. Re-register NSX in the manager. See ["Add a VMware vCenter" on page 681](#).

Set up communication

- Allow inbound and outbound communication to and from the appliance on the appropriate port numbers. See ["Deep Security port numbers" on page 411](#).
- Make sure the virtual appliance—known as a 'service VM' in VMware terminology—can communicate with the partner Service Manager (console) at the management network level. For details, see [Deploy a Service for East-West Traffic Introspection](#) or this [NSX-V help page](#).

(Optional) Install Deep Security Agents

- If the features you want are not available agentlessly, install agents on your VMs and use ['combined mode'](#) so that protection duties are shared by the virtual appliance and agent.
- If you configured guest VMs to have direct access to a network card, install agents on those VMs. In this case there is no opportunity to intercept packets and an in-guest agent is preferable. See ["Choose agentless vs. combined mode protection" on page 548](#) for details.

(Optional) Configure high-availability

If you want to use VMware Distributed Resource Scheduler (DRS) for high availability (HA), [configure DRS](#).

Next steps

You are now ready to deploy the appliance. Proceed to one of these pages depending on your VMware environment:

- ["Deploy the appliance \(NSX-T 3.x\)" on the next page](#)
- ["Deploy the appliance \(NSX-V\)" on page 589](#)
- ["Deploy the appliance in a vCloud environment" on page 612](#)

Configure VMware DRS

If you're planning on using VMware Distributed Resource Scheduler (DRS) for high availability (HA), configure DRS before installing the Deep Security Virtual Appliance. After DRS is configured, deploy the virtual appliance on all ESXi servers (including backup ESXi servers), and use [affinity settings](#) "pin" them to each ESXi server. This ensures that agentless protection is still being applied after HA failover.

Warning: If DRS moves a VM from an ESXi server that has an appliance to one that doesn't, the VM will become unprotected. If the VM then returns to the original ESXi server, it still won't be protected again *unless* you create an event-based task to re-activate and protect a VM when it is moved onto an ESXi server with an appliance. For more information, see ["Automatically perform tasks when a computer is added or changed \(event-based tasks\)" on page 1769](#).

Warning: Don't apply vMotion to the appliance. Keep each appliance on its specific ESXi server: in the DRS settings, select **Disabled** (recommended) or **Manual**. Alternatively, deploy the appliance onto local storage, not shared storage. When the virtual appliance is deployed onto local storage, DRS won't apply vMotion. For more information, see your VMware documentation.

Deploy the appliance (NSX-T 3.x)

The Deep Security Virtual Appliance will reach [end of extended support \(EOL\)](#) on 31-Dec-2027 or VMware's end of support date for NSX-4.X, whichever comes first.

This document describes how to perform a fresh appliance deployment.

To upgrade an existing appliance deployment, follows the instructions provided in "[Upgrade Deep Security Virtual Appliance](#)" on page 1633.

To deploy the appliance, follow these steps:

- "[Import the appliance](#)" below
- "[Prepare Fabric settings](#)" on the next page
- "[Add vCenter to Deep Security Manager](#)" on page 566
- "[Install the appliance on NSX-T 3.x](#)" on page 567
- "[Create a group for protection](#)" on page 573
- "[Configure east-west security](#)" on page 575
- "[Configure Endpoint Protection](#)" on page 579
- "[Configure activation](#)" on page 581
- "[Next steps \(how to add new VMs\)](#)" on page 588

Import the appliance

After completing the tasks in "[Before deploying the appliance](#)" on page 551, you are ready to import the appliance ZIP into Deep Security Manager.

Tip: As an alternative to importing the appliance ZIP, you can place the OVF file at a URL location to make it faster for NSX to download. For details, see "[Configure the appliance OVF location](#)" on page 626.

1. Go to:

<https://help.deepsecurity.trendmicro.com/software.html>

2. Download the Deep Security Virtual Appliance package. Check the version requirements in [system requirements](#).

You can import multiple versions of the appliance. The manager will choose the newest package.

3. On Deep Security Manager, go to **Administration > Updates > Software > Local**.
4. Click **Import** and upload the package to Deep Security Manager.

On import, Deep Security Manager *also* automatically downloads and imports an agent that is compatible with the operating system of the virtual appliance VM. This agent has the same protection modules as Deep Security Agent for 64-bit Red Hat Enterprise Linux.

5. If you want to specify a different embedded agent, go to **Administration > System Settings > Updates** and look for **Virtual Appliance Deployment**. By default, the **Virtual Appliance Deployment** option is set to **Latest Available (Recommended)**. This indicates to the manager to upgrade the virtual appliance to use the newest imported, embedded agent. Change this setting, as required.

You have now imported the appliance.

Prepare Fabric settings

You must now prepare Fabric settings.

- ["Configure the User Interface Mode Toggle" below](#)
- ["Configure a Compute Manager" on the next page](#)
- ["Configure a Transport Zone" on page 557](#)
- ["Configure a Transport Node Profile" on page 558](#)
- ["Prepare the host" on page 562](#)
- ["Create a logical switch" on page 564](#)

Configure the User Interface Mode Toggle

First, configure the user interface settings of NSX-T Manager so that you can access the different mode for later configurations.

1. In NSX-T Manager, at the top, click **System**, and then click **User Interface Settings** on the left.

2. Set Toggle Visibility and Default Mode as you like.

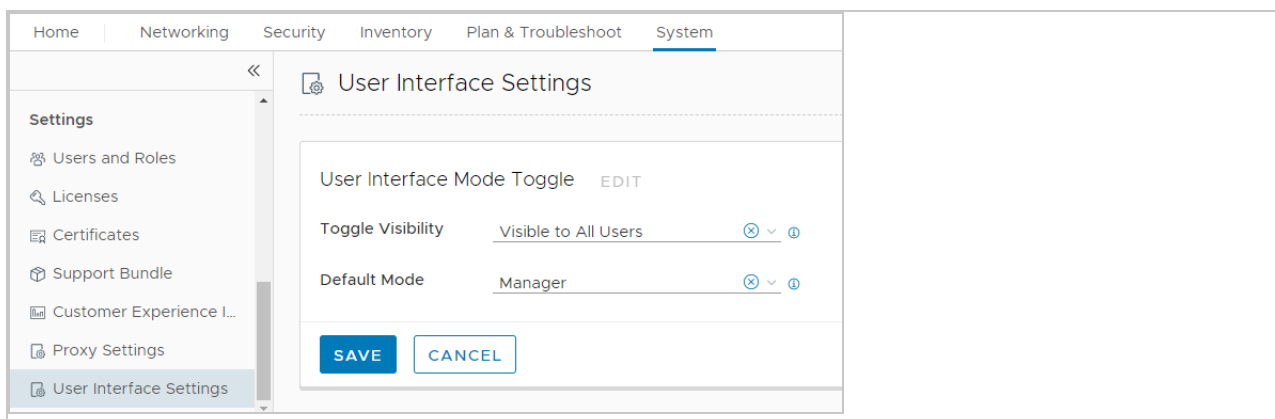

Configure a Compute Manager

Next, add your vCenter as a Compute Manager:

1. Make sure the vCenter and ESXi servers have been configured for management.
2. In NSX-T Manager, at the top, click **System**, and then click **Fabric > Compute Managers** on the left.
3. Click **+ADD**.
4. The **New Compute Manager** dialog box appears.
5. Fill in the fields with your vCenter information. In this example, the vCenter is `10.209.48.73`.

New Compute Manager ? ×

Name* 10.209.48.73

Description vCenter - 10.209.48.73

Type* vCenter

FQDN or IP Address* 10.209.48.73

HTTPS Port of Reverse Proxy* ⓘ 443

Username* administrator@vsphere.local

Password*

SHA-256 Thumbprint

Enable Trust ⓘ No
Supported for vCenter Server 7.0 or later

CANCEL
ADD

6. Click **Add**. The vCenter is added.

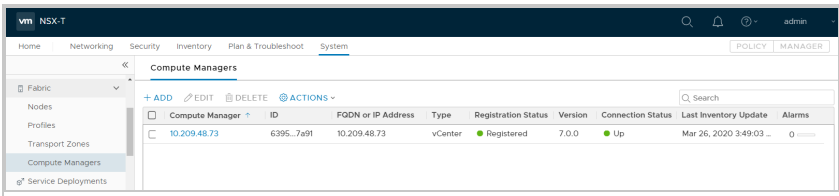

Compute Manager	ID	FQDN or IP Address	Type	Registration Status	Version	Connection Status	Last Inventory Update	Alarms
10.209.48.73	6395-7a91	10.209.48.73	vCenter	Registered	7.0.0	Up	Mar 26, 2020 3:49:03 ...	0

7. Verify that the vCenter's **Registration Status** is **Registered**, and its **Connection Status** is **Up**.

You have now added your vCenter.

Configure a Transport Zone

Next, make sure an overlay transport zone exists, and if not create one:

Tip: If you already have a transport zone, you can use it and don't need to create one.

1. Still in NSX-T Manager, go to **System > Fabric > Transport Zones**.
2. Check whether a transport zone with a **Traffic Type** of **Overlay** already exists.
3. If an overlay transport zone does not exist, click **+ADD** to create one.

The **New Transport Zone** dialog box appears.

New Transport Zone ⓘ ×

Name *

Description

Switch Name

Traffic Type Overlay VLAN

Uplink Teaming Policy Names

4. Set the **Name** to the the transport zone name. Example: `transport-zone-overlay`.
5. Set the **Traffic Type** to **Overlay**.
6. Click **ADD**.

An overlay transport zone is created.

Configure a Transport Node Profile

Next, create a Deep Security transport node profile:

Tip: If you already have a Transport Node Profile, you can use it and don't need to create one.

1. Still in NSX-T Manager, on the left, click **Fabric > Profiles**, and then in the main pane, click **Transport Node Profiles**.
2. Click **+ ADD** to create a transport node profile.

The **Add Transport Node Profile** dialog box appears.

3. Add a Node Switch Profile depending on your requirements

Note: VMware recommends that new NSX deployments with ESXi 7.0 use VDS 7.0. If you've upgraded from a previous NSX-T version you can continue to use N-VDS. For more information, see the [Deep Security and VMware compatibility matrix](#) and NSX-T release notes.

Method 1: Add VDS Node Switch Profile

Fill out the fields as follows:

- For the **Name**, enter a name. Example: `transport-node-profile`.
 - For the **Description**, enter a description. Example: `Transport Node Profile`.
 - Under **New Node Switch**, for the **Type**, select **VDS**.
 - For the **Name**, choose the vCenter and VDS.
 - For the **Transport Zone**, select the transport zone created in the previous step. Example: `transport-zone-overlay`.
 - For the **Uplink Profile**, select `nsx-default-uplink-hostswitch-profile`.
 - For the **IP Assignment**, select either option.
 - Under **Teaming Policy Switch Mapping**, assign **VDS Uplinks** to the **Uplinks**. In the example, we assigned `Uplink 1` to **uplink-1 (active)**. You can check the workable uplinks in the vCenter console by clicking a host and going to **Configure > Networking > Virtual switches**.
-

Add Transport Node Profile ? ×

Name*

Description

+ ADD SWITCH

▼ New Node Switch

Type* N-VDS VDS

Mode* Standard (All hosts) Enhanced Datapath

Name*

Transport Zone* OR Create New Transport Zone

Uplink Profile* OR Create New Uplink Profile

IP Assignment*

Teaming Policy Switch Mapping

Uplinks	VDS Uplinks
<input type="checkbox"/> uplink-1 (active)	Uplink 1
<input type="checkbox"/> uplink-2 (standby)	

Method 2: Add N-VDS Node Switch Profile

Fill out the fields as follows:

- For the **Name**, enter a name. Example: `transport-node-profile`.
- For the **Description**, enter a description. Example: `Transport Node Profile`.
- Under **New Node Switch**, for the **Type**, select **N-VDS**.
- For the **Mode**, select either option. In the example, we selected **Standard (All hosts)**.
- For the **Name**, enter a name for the switch. Example: `n-vds-overlay`.
- For the **Transport Zone**, select the transport zone created in the previous step. Example: `transport-zone-overlay`.
- For the **NIOC Profile**, select `nsx-default-nioc-hostswitch-profile`.
- For the **Uplink Profile**, select `nsx-default-uplink-hostswitch-profile`.
- For the **LLDP Profile**, select either option.
- For the **IP Assignment**, select either option.
- Under **Teaming Policy Switch Mapping**, assign valid physical NICs to the **Uplinks**. In the example, we assigned `vmnic2` to **uplink-1 (active)**.

Note: The assigned NIC(s) must be available on the ESXi servers. In the example, our ESXi hosts have `vmnic2` which can be used for the N-VDS `n-vds-overlay`.

For details on any of the values, click



at the top of the dialog box.

The bottom portion of the dialog box now looks similar to the following:

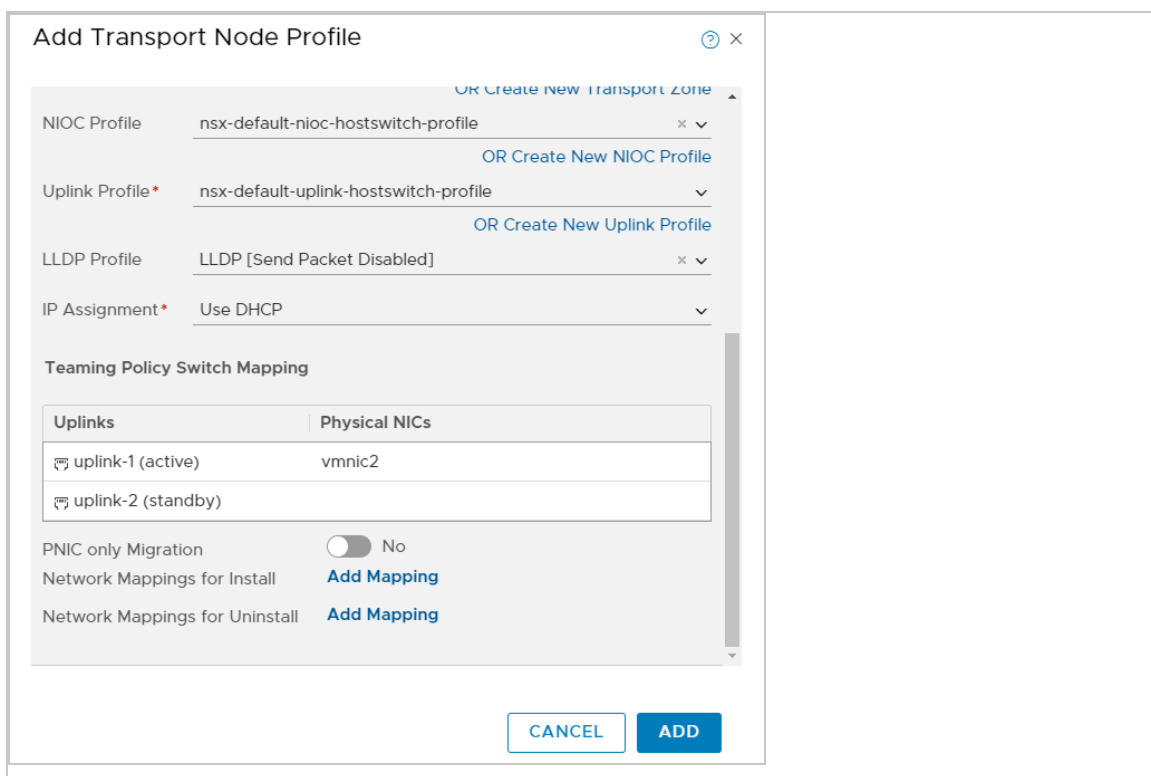

4. After filling out the fields, click **ADD**.

A transport node profile called **transport-node-profile** is created.

Prepare the host

Next, apply the Deep Security transport profile to your clusters.

1. Still in NSX-T Manager, click **Fabric > Nodes**, and in the main pane click **Host Transport Nodes**.
2. From the **Managed by** drop-down list, select the vCenter you added previously. In this example, the vCenter is `10.209.48.73`.

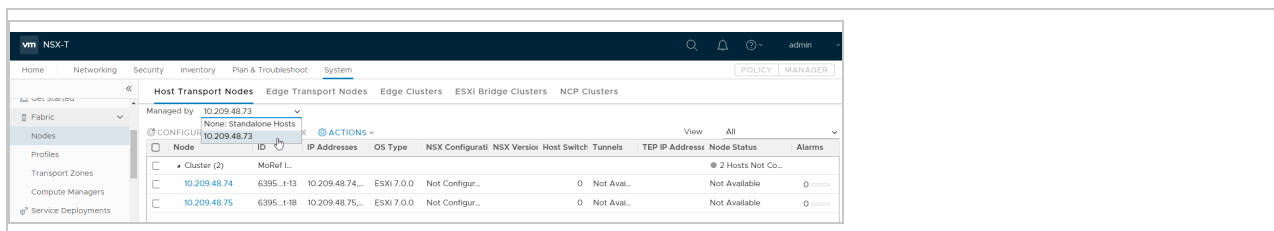

3. Select a cluster that contains the VMs that you want to protect with Deep Security Virtual Appliance. If there is more than one cluster, select all the ones that you want to protected with Deep Security Virtual Appliance.
4. Click **CONFIGURE NSX**.

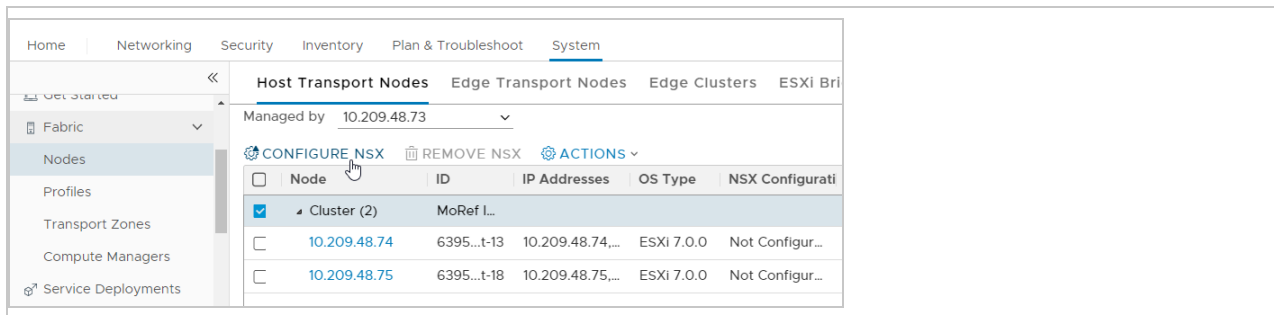

5. From the **Select Deployment Profile** drop-down list, select **transport-node-profile** or whatever you called your transport node profile.

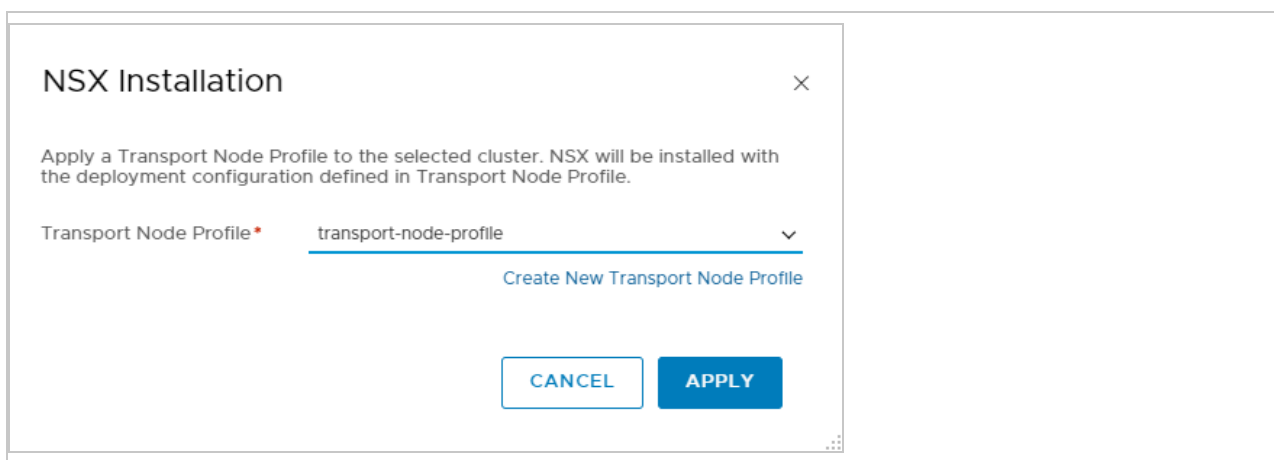

6. Click **SAVE**. The following occurs:
 - The Deep Security transport node profile is applied to the clusters.
 - While the profile is being applied, an **Applying Profile** message may appear and you can check the installation progress on each node.
 - When the operation finishes, each node's NSX Configuration changes to **Success** and its **Node Status** changes to **Up**. If you have multiple ESXi servers, they should all be marked with **Success** and **Up**.

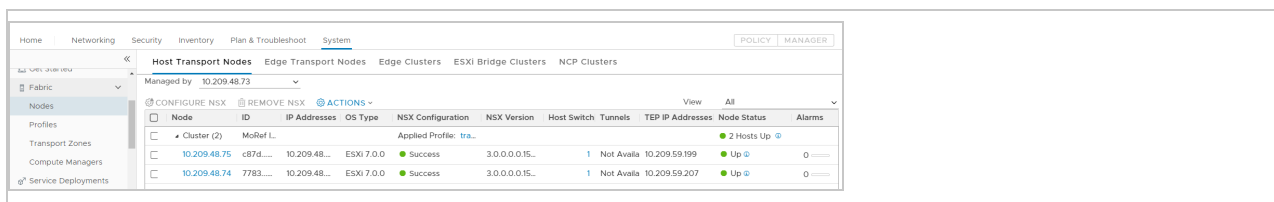

You have now configured the target cluster.

Create a logical switch

Next, if you are using NSX Data Center Advanced, NSX Data Center Enterprise Plus or NSX Data Center for Remote Office Branch Office Edition, you must configure the logic switch for network traffic inspection. If you are using another NSX edition, skip this section.

Tip: If you already have a logical switch, you can use it and don't need to create a new one.

1. Still in NSX-T Manager, at the top, click **Networking** and toggle to **MANAGER**.
2. On the left, click **Logical Switches**.
3. In the main pane, click **+ ADD**.

The **Add New Logical Switch** dialog box appears.

4. On the **General** tab:
 - For the **Name**, enter a name for your logical switch. Example: `logical-switch-overlay`.
 - For the **Transport Zone**, choose the overlay transport zone created previously. Example: `transport-zone-overlay`.
 - For the **Uplink Teaming Policy Name**, select **[Use Default]**.
 - For the **Admin Status**, keep the default value.
 - For the **Replication Mode**, select either option.
 - For the **VLAN**, leave the field blank.

Add New Logical Switch ⓘ ×

General Switching Profiles

Name* logical-switch-overlay

Description Logical Switch - Overlay

Transport Zone* transport-zone-overlay ▾

Uplink Teaming Policy Name* [Use Default] ▾

Admin Status Up

Replication Mode Hierarchical Two-Tier replication
 Head replication

VLAN

Only VLAN Trunk Spec is allowed (eg: 1, 5, 10-12, 31-35).

CANCEL ADD

5. On the **Switching Profiles** tab, select the profile you want for each item. In the example, we kept **[Use Default Profile]** for all items.

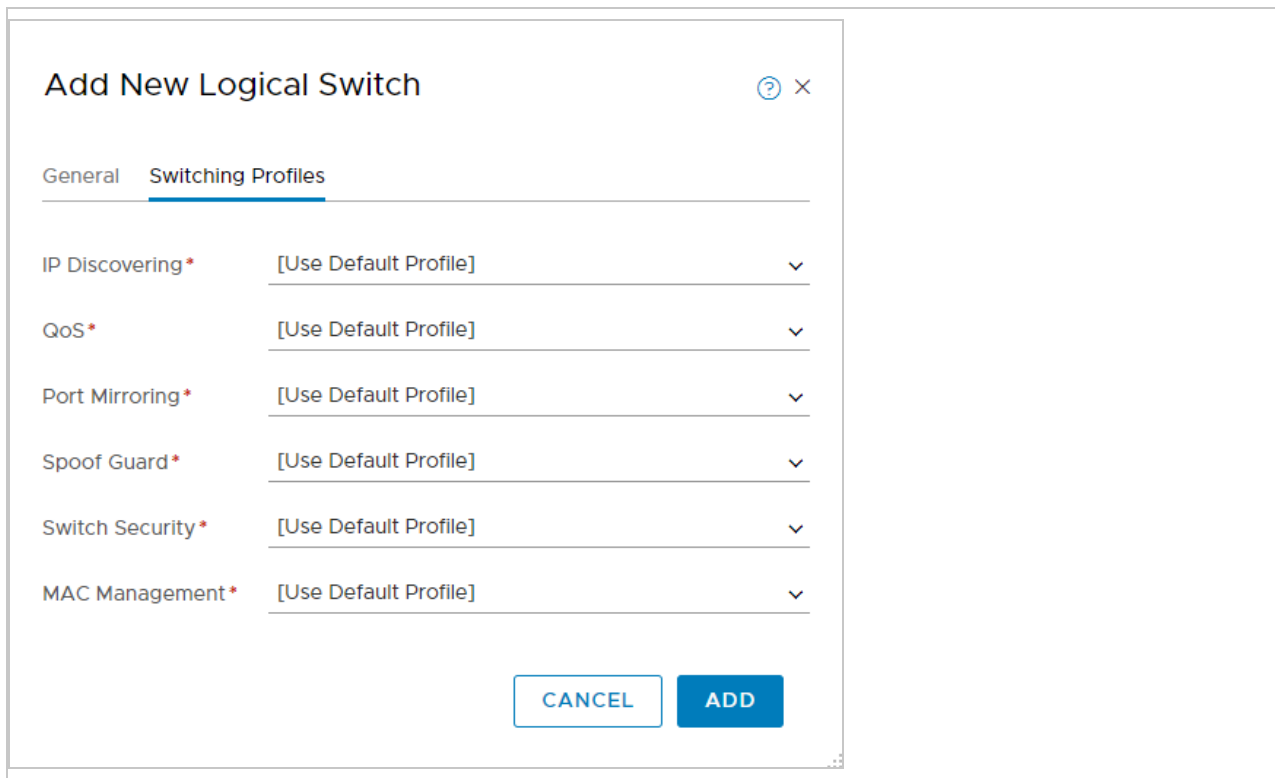

6. Click **ADD**.

A logical switch is created. You can check the switch status on your host(s) through vSphere Client.

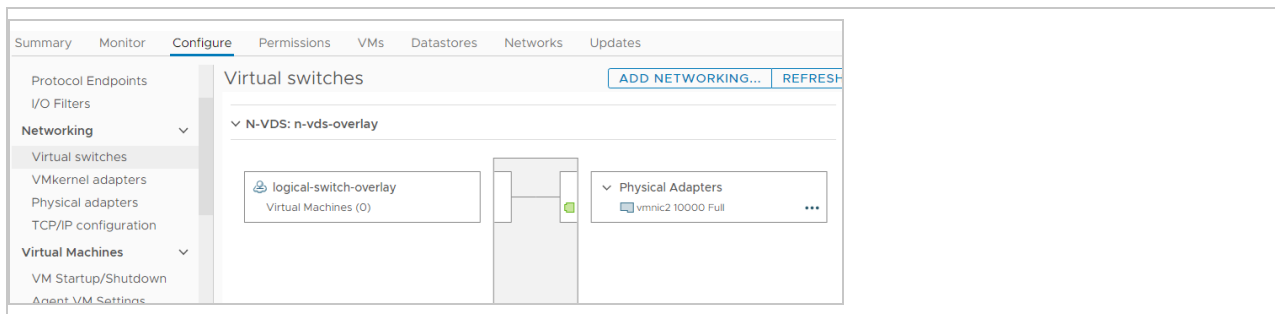

You have now prepared the Fabric settings in NSX-T Manager.

Add vCenter to Deep Security Manager

You must now add vCenter.

Follow the instructions in ["Add a VMware vCenter" on page 681](#).

After you have finished:

- your guest VMs are displayed in Deep Security Manager.
- the Trend Micro Deep Security service is registered with NSX-T.

Install the appliance on NSX-T 3.x

The Deep Security Virtual Appliance will reach [end of extended support \(EOL\)](#) on 31-Dec-2027 or VMware's end of support date for NSX-4.X, whichever comes first.

You must now install the appliance on NSX-T 3.x.

Follow these instructions:

- "Begin the service deployment" below
- "Configure and start the service deployment" on the next page
- "Monitor and verify the deployment" on page 571
- "Monitor and verify the deployment" on page 571
- "Repeat all steps for each cluster" on page 573

Begin the service deployment

1. In NSX-T Manager, click **System**, and then on the left, select **Service Deployments**.

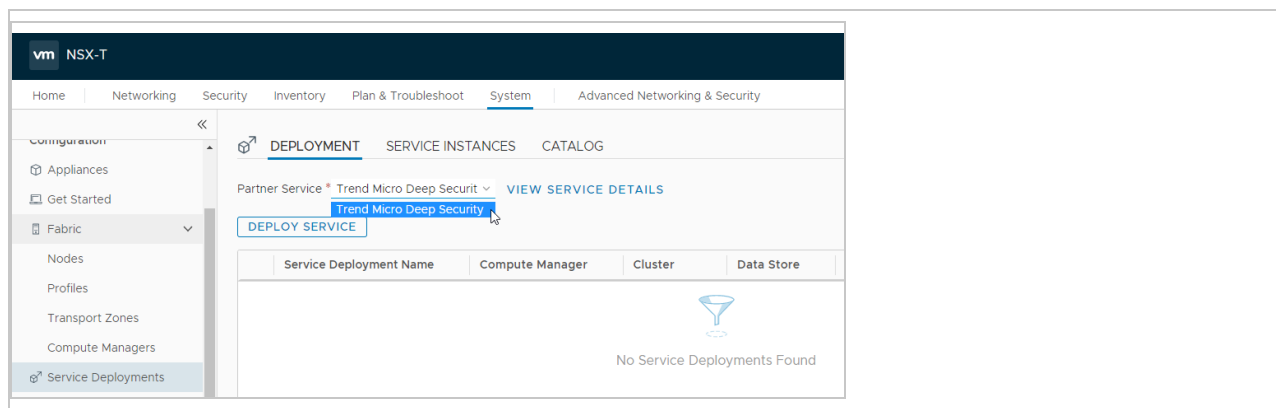

2. From the **Partner Service** drop-down list, select **Trend Micro Deep Security**. This Trend Micro Deep Security service was registered when you added your vCenter in Deep Security Manager previously.
3. Click **DEPLOY SERVICE**.

A blue panel appears.

- Fill out the blue panel as described in "Configure and start the service deployment" below.

Configure and start the service deployment

Fill out the service deployment fields as described below and then click **SAVE** to begin the deployment.

Set the Service Deployment Name

In the **Service Deployment Name** field, enter a name. If you have multiple clusters, consider using a name that includes the name of the cluster of which you're deploying. The cluster is listed under the **Cluster** heading on the same page. Example: `dsva-vc73-cluster`.

Set the Compute Manager

From the **Compute Manager** drop-down list, select the vCenter you added previously. In our example, the vCenter is `10.209.48.73`.

Set the Cluster

From the **Cluster** drop-down list, select a cluster you configured previously. The Trend Micro Deep Security service will be installed to all the ESXi servers in this cluster. If you have multiple clusters, pick one now. You can come back later to pick another cluster.

Set the Data Store

From the **Data Store** drop-down list, select the option that is appropriate for your environment. In our example, we selected **Specified on Host**.

Set the Networks

Under **Networks**:

1. Click **Set** or **Edit Details**, whichever is available.
2. Select the **ens0 - Management Nic** check box.
3. Choose the **Network** and **Network Type** you want to use.
4. Enable the **ens2 - Data-1 NIC** check box to obtain east-west security functionality.
5. Click **SAVE** to save your network settings.

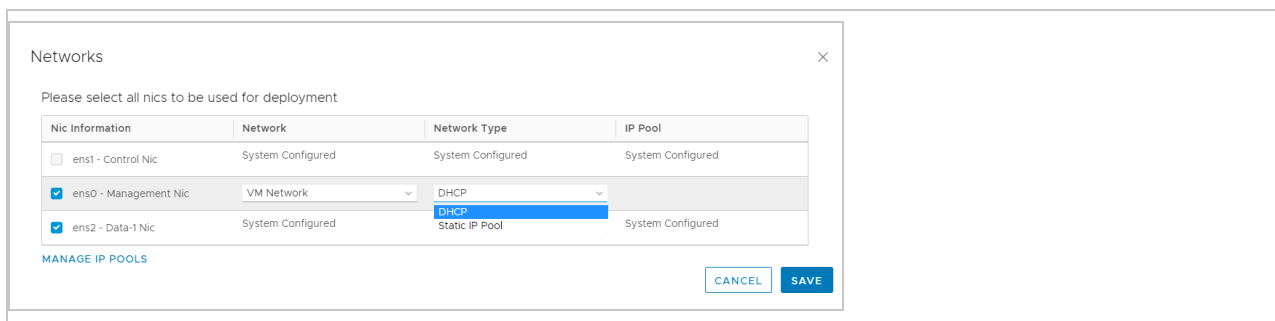

Set the Deployment Specification

From the **Deployment Specification** drop-down list:

1. Select the **Deep Security -<version>-SMALL - small, MEDIUM - medium, or LARGE - large** option, depending on the size of your deployment. If you're not sure of the size of your deployment, review the information in "[Deep Security Virtual Appliance sizing](#)" on [page 407](#). In our example, we selected **Deep Security - 12.0.0-682-SMALL - Small**.
2. If you previously [configured the OVF at a URL location](#), make sure to select the same size OVF as you did before. For example, if you configured the URL of the small OVF previously, then make sure to select the small OVF under **Deployment Specification**.

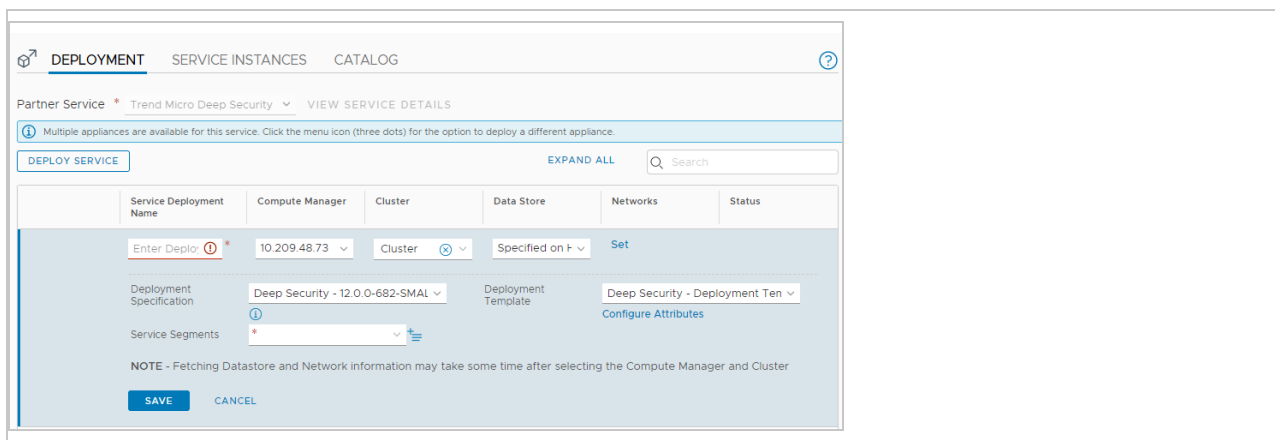

3. Click



to view the OVF URL from which NSX will download the appliance OVF.

Note: If you [specified a different URL for the OVF](#), then that URL will be used instead.

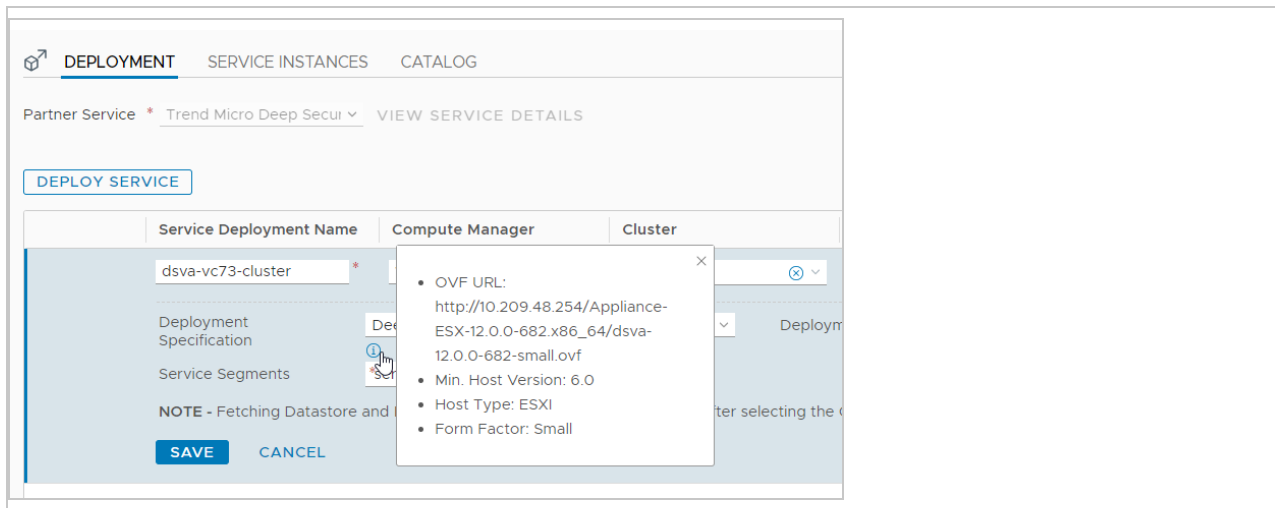

Set the Service Segment

From the **Service Segment** drop-down list, select a service segment that is configured to use your overlay transport zone.

If you do not yet have a service segment, create one as follows:

1. Click **Action**.

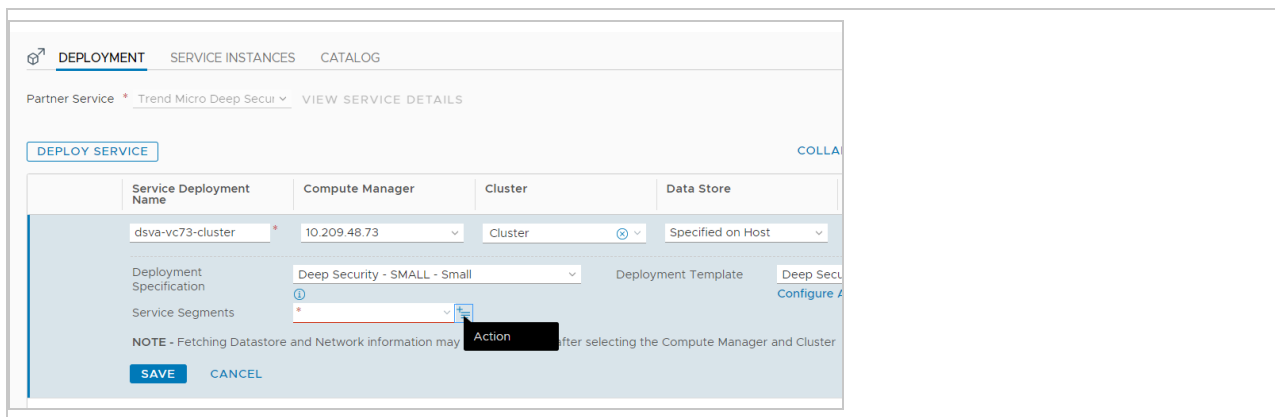

The **Service Segment** dialog box appears.

2. Click **ADD SERVICE SEGMENT**.
3. Under **Name**, enter a name such as `service-segment`.
4. Under **Transport Zone (Overlay)**, select `transport-zone-overlay` or whichever overlay transport zone you're using.
5. Leave **Connected To** empty.

6. Click **SAVE** and then **CLOSE**. A service segment is created.
7. From the **Service Segments** drop-down list, select the service segment you just created.

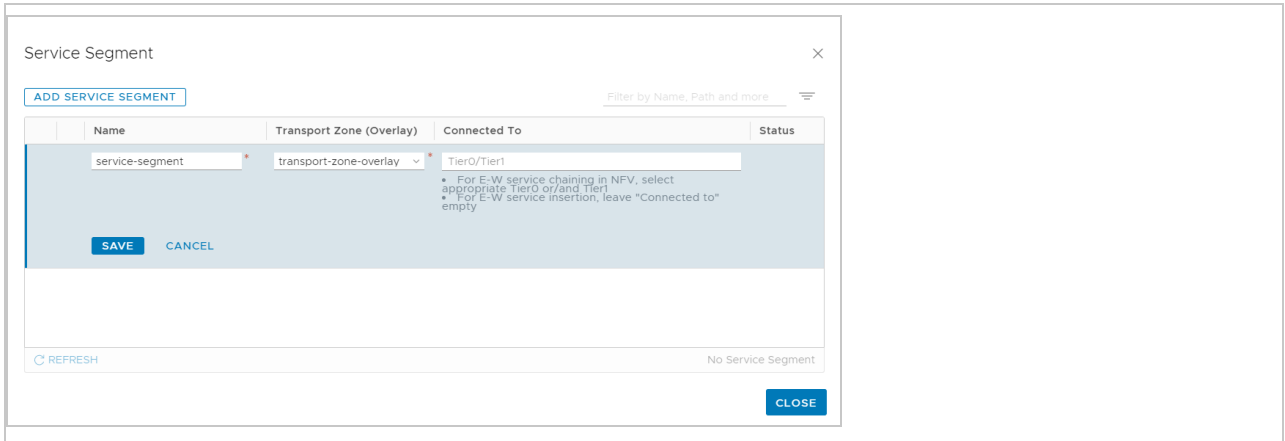

Set the Deployment template

1. From the **Deployment Template** drop-down list, select **Deep Security - Deployment Template**.
2. (Optional) If you would like to configure the CPU usage of the appliance in DPDK mode click **Configure Attributes** and modify the **dpdkMode** field. For details on DPDK and how to it works with the appliance, see "[Configure DPDK mode](#)" on page 622.

Your service deployment details should look similar to the following:

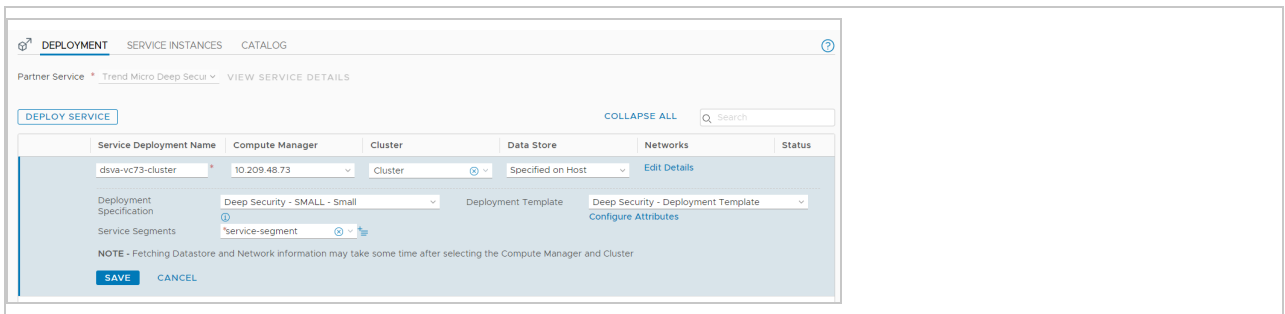

Monitor and verify the deployment

After starting the deployment, you can monitor it in NSX-T 3.x and vSphere Client, and then verify it in Deep Security Manager.

Trend Micro Deep Security On-Premise 20

Monitor the deployment in NSX-T 3.x

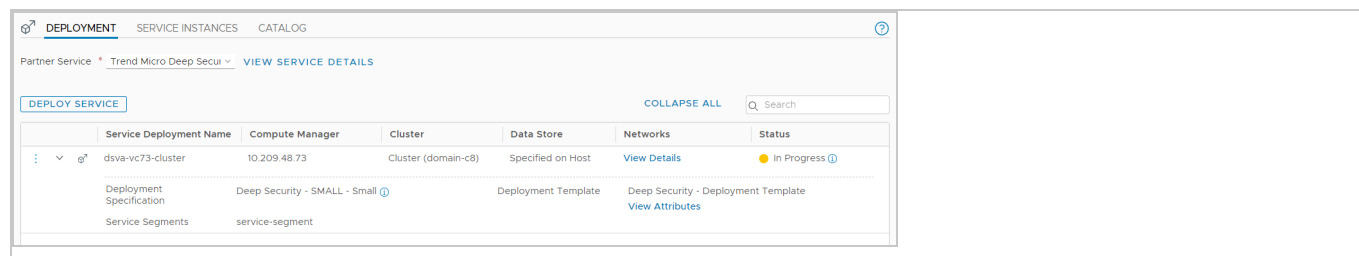

The **Status** column in NSX-T Manager indicates **In Progress**.

When the deployment is finished, the **Status** changes to **Up**.

If you have multiple ESXi servers in the assigned cluster, then a Trend Micro Deep Security service is deployed onto each ESXi server. The services will be labeled as follows to differentiate them.

- Trend Micro_Deep Security - SMALL (1) (for the first ESXi server)
- Trend Micro_Deep Security - SMALL (2) (for the second ESXi server)
- ... and so on.

Monitor the deployment in vSphere Client

You can check the status of the deployment by accessing vCenter through the vSphere Client. The vSphere Client shows the progress in more detail. Wait until the **Status** changes to **Complete**.

In the image below, you see two Trend Micro Deep Security services listed on the left. Two services were deployed because there were two ESXi servers in the cluster.

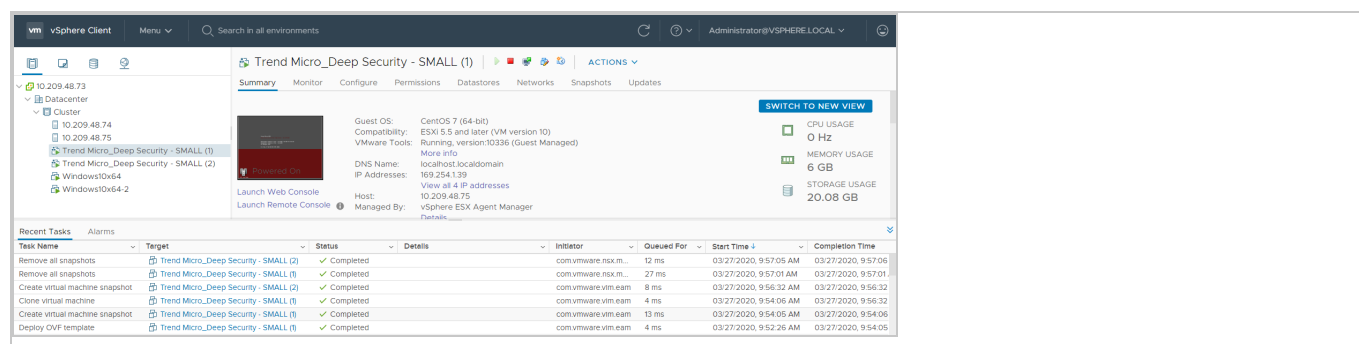

Verify the deployment in Deep Security Manager

You can verify the deployment in Deep Security Manager by clicking **Computers** at the top and then on the left, expanding the vCenter where the Trend Micro Deep Security service was deployed.

Trend Micro_Deep Security (1) appears under **Virtual Machines > Datacenter > ESX Agents** with a **Platform** of **Deep Security Virtual Appliance**. You see one virtual appliance per ESXi server in your cluster.

Note: Although your VMs appear in Deep Security Manager, they are not yet protected.

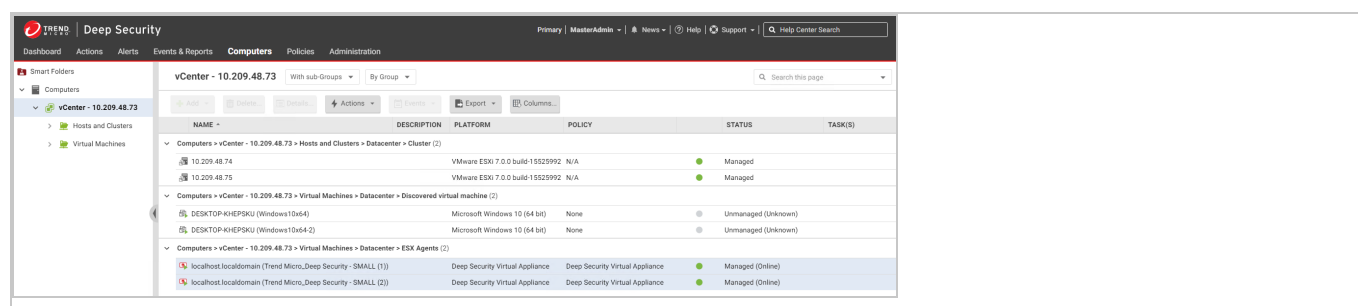

Repeat all steps for each cluster

Repeat all the steps in "[Install the appliance on NSX-T 3.x](#)" on page 567 for each cluster.

You have now installed the appliance on NSX-T 3.x.

Create a group for protection

You must now create a group that will contain the VMs you want to protect with the Deep Security Virtual Appliance:

1. In NSX-T Manager, at the top, click **Inventory**, toggle to **POLICY**, and then on the left, click **Groups**.
2. Click **ADD GROUP** to create a group which will contain the VMs protected by Deep Security Virtual Appliance. Fill out the fields as follows:
 - For the **Name**, enter a name for your group. Example: `dsva-protection-group`.
 - For the **Compute Members**, click **Set Members** and select which VMs will go in the group.

Note: The following instructions demonstrate the simplest way to add members. For more complex ways, such as the use of **Membership Criteria**, see the NSX-T documentation.

3. Click **Members (0)** at the top, and then select **VirtualMachine (selected: 0)** in the **Select Category** drop-down list.
4. Click **Refresh** at this bottom if your VMs are not visible.
5. Select the guest VMs you want to add to the group. These VMs will become protected by the Deep Security Virtual Appliance.

Your **Select Members** dialog box now looks similar to the following:

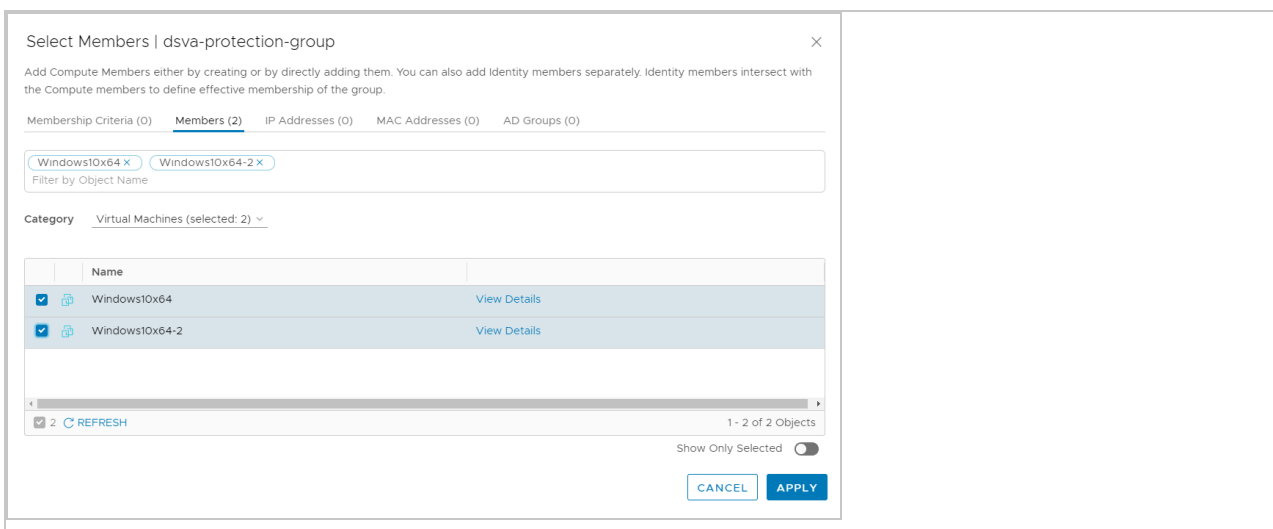

6. Verify the VM count in the **Members** tab near the top. In the example above, the count is **2 - Members (2)**.
7. Click **APPLY**.

The **ADD GROUP** page now shows an updated count.

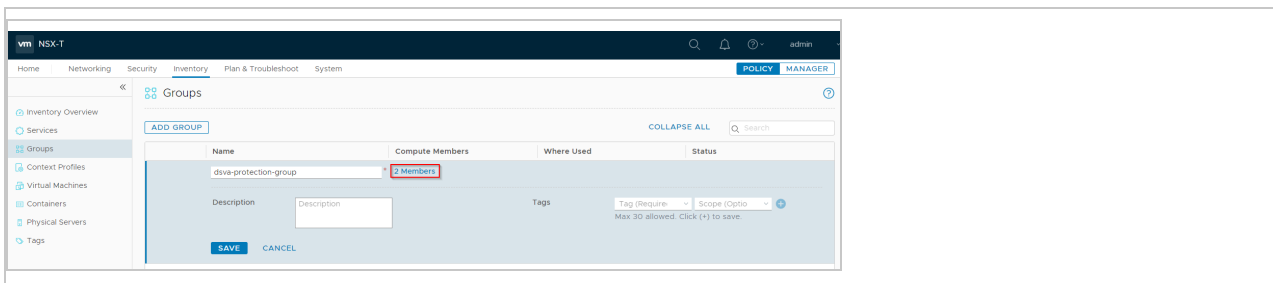

8. Click **SAVE**.

You have now added a group with some members. You may repeat the steps to create more groups.

Configure east-west security

Configuring east-west security is necessary to enable the networking functionality required for the Integrity Monitoring, Intrusion Prevention, Firewall, and Web Reputation features.

Follow the steps below to configure east-west security:

- "Add a service profile" below
- "Add a service chain" on the next page
- "Add a Network Introspection policy" on page 577
- "Connect VMs to the logical switch" on page 578

Add a service profile

1. In NSX-T Manager, click **Security** at the top, toggle to **POLICY**, and then on the left, find **Settings** and click **Network Introspection Settings**.
2. In the main pane, click **SERVICE PROFILES**.
3. From the **Partner Service** drop-down list, select **Trend Micro Deep Security** if it is not already selected.
4. Click **ADD SERVICE PROFILE** and fill out the fields as follows:
 - For the **Service Profile Name**, specify a name. Example: `dsva-service-profile-ni`.
 - For the **Service Profile Description**, enter a description. Example: `Deep Security Service Profile for Network Introspection`.
 - For the **Vendor Template**, select **Default (EBT)_Network**. This template was loaded at the same time as the Trend Micro Deep Security service.

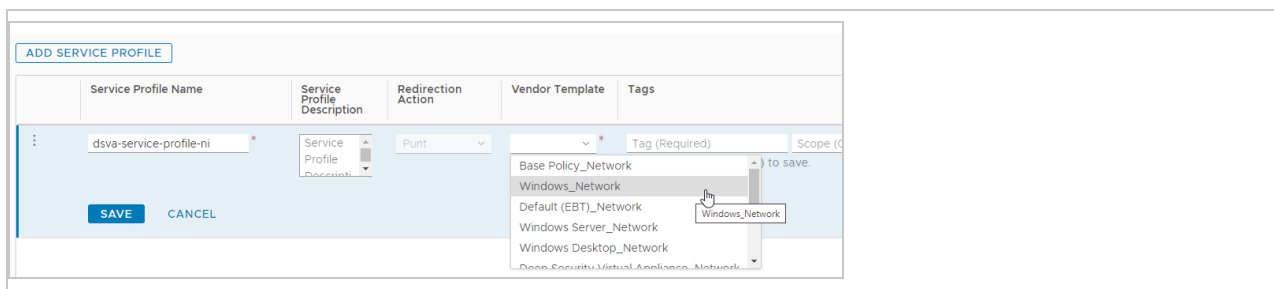

5. The **ADD SERVICE PROFILE** page should now look similar to the following:

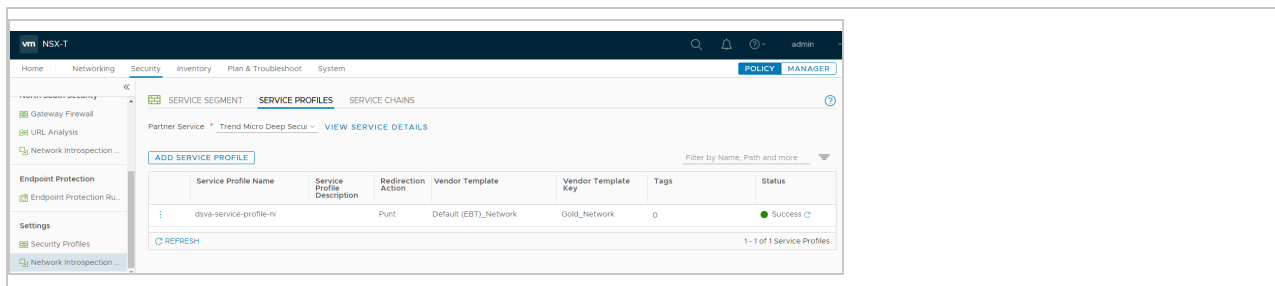

6. Click **SAVE**.

Add a service chain

1. On the main pane, click the **SERVICE CHAINS** tab, and click **ADD CHAIN**. Fill out the fields as described in the following steps.
2. For the **Name**, specify a name. Example: `dsva-service-chain`.
3. For the **Service Segments**, select the service segment created previously. Example: `service-segment`.
4. For the **Forward Path**:
 - Click **Set Forward Path** to open the dialog box.
 - Click **ADD PROFILE IN SEQUENCE** and add the service profile created previously. In the example, we selected `dsva-service-profile-ni`.
 - Click **ADD**.
 - Click **SAVE**.

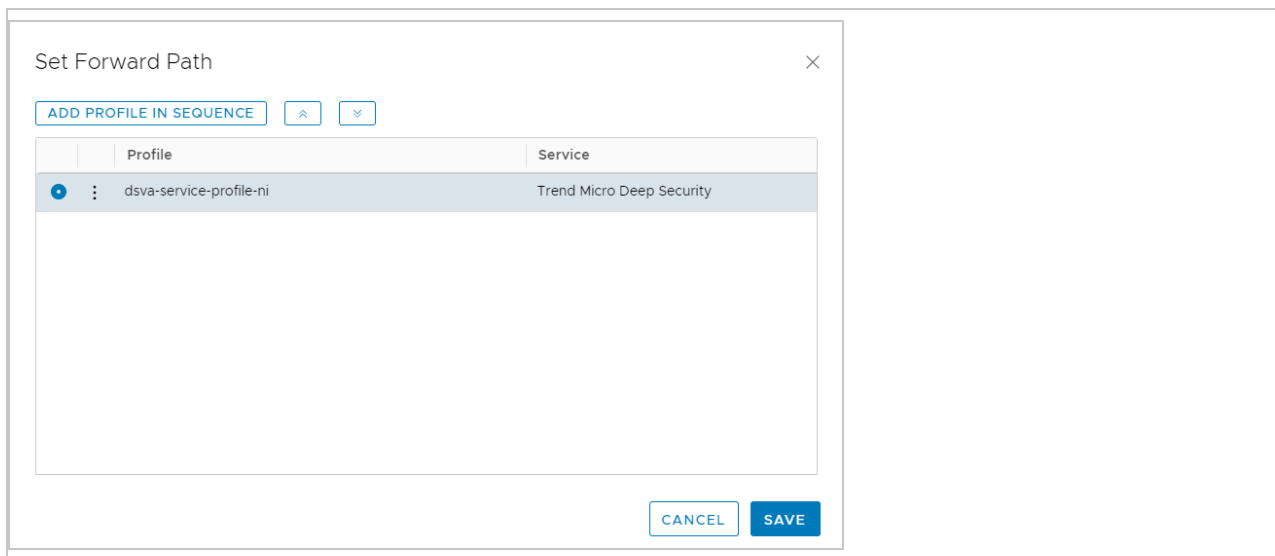

You're now back on the main **SERVICE CHAINS** page. Continue with the **SERVICE CHAIN** configuration below.

5. For the **Reverse Path**, keep the **Inverse Forward Path** check box selected.
6. For the **Failure Policy**, select **Allow**.

The service chain should now look like the following:

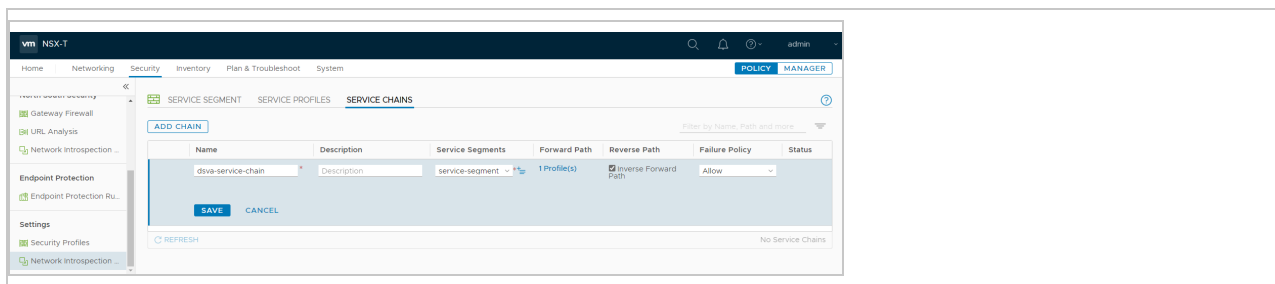

7. Click **SAVE**.

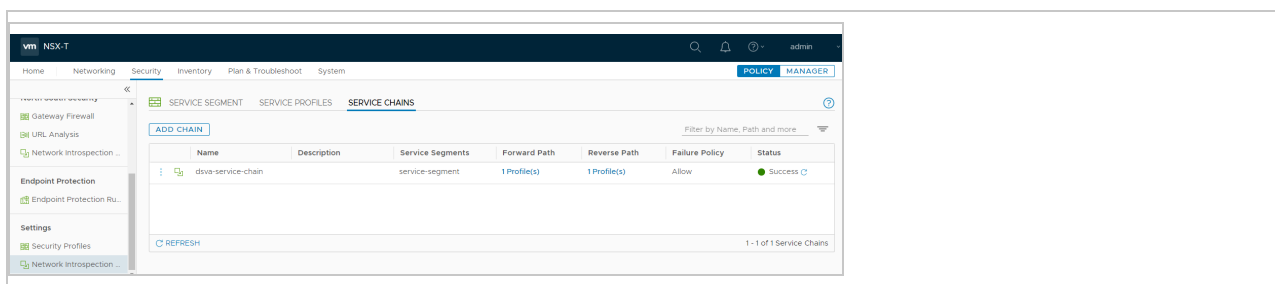

Add a Network Introspection policy

1. Click **Security** at the top, toggle to **POLICY**, and then on the left, find **East West Security** and click **Network Introspection (E-W)**.
2. In the main pane, click **+ ADD POLICY**.
3. In the **Name** column, click within the **New Policy** cell and change the name. For example, use `dsva-policy-ni`. For **Redirect To**, select the service chain. In this example, we used `dsva-service-chain`.
4. Select the check box next to `dsva-policy-ni` and click **+ ADD RULE**. A rule appears under `dsva-policy-ni`. Click **+ ADD RULE** again because we need 2 rules.
5. Configure the 1st rule for inbound traffic:
 - For the **Name**, enter a name for the rule. Example: `rule-in`.
 - For the **Sources**, keep **Any**.
 - For the **Destinations**, select `dsva-protection-group`.
 - For the **Services**, keep **Any**.

Trend Micro Deep Security On-Premise 20

- For the **Applied To**, select **dsva-protection-group**.
 - For the **Action**, select **Redirect**.
6. Configure the 2nd rule for outbound traffic:
- For the **Name**, enter a name for the rule. Example: `rule-out`.
 - For the **Sources**, select **dsva-protection-group**.
 - For the **Destinations**, keep **Any**.
 - For the **Services**, keep **Any**.
 - For the **Applied To**, select **dsva-protection-group**.
 - For the **Action**, select **Redirect**.

There is now a mapping between the VMs in the `dsva-protection-group` and the Default (EBT)_Network template specified in the `dsva-service-chain`.

The policy should now look similar to the following:

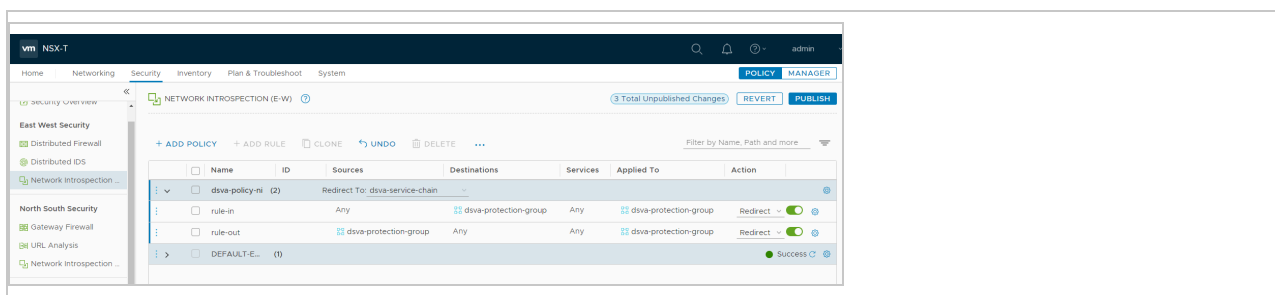

7. Click **PUBLISH** to finish the policy and rule creation.

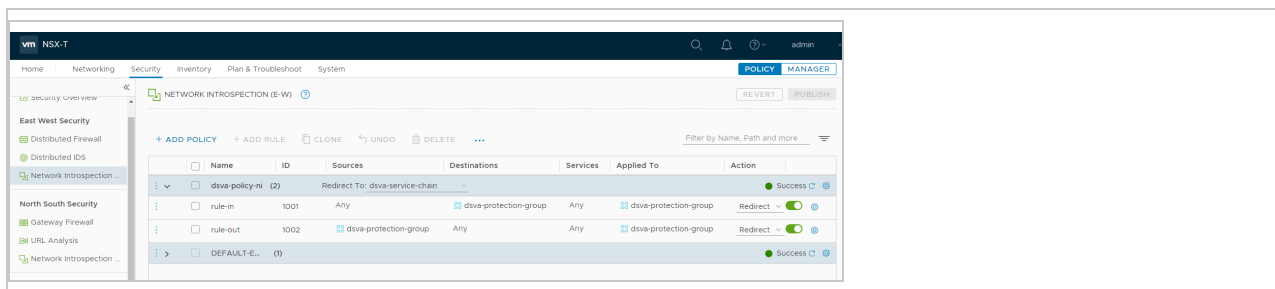

Connect VMs to the logical switch

In order for the VMs in your group to be protected by east-west security in NSX-T, those VMs connected to the [logical switch created in an earlier step](#).

In the example, we connected the **Network adapter 1** to **logical-switch-overlay**. You can check that your VMs are connected to this switch by accessing vCenter through vSphere Client.

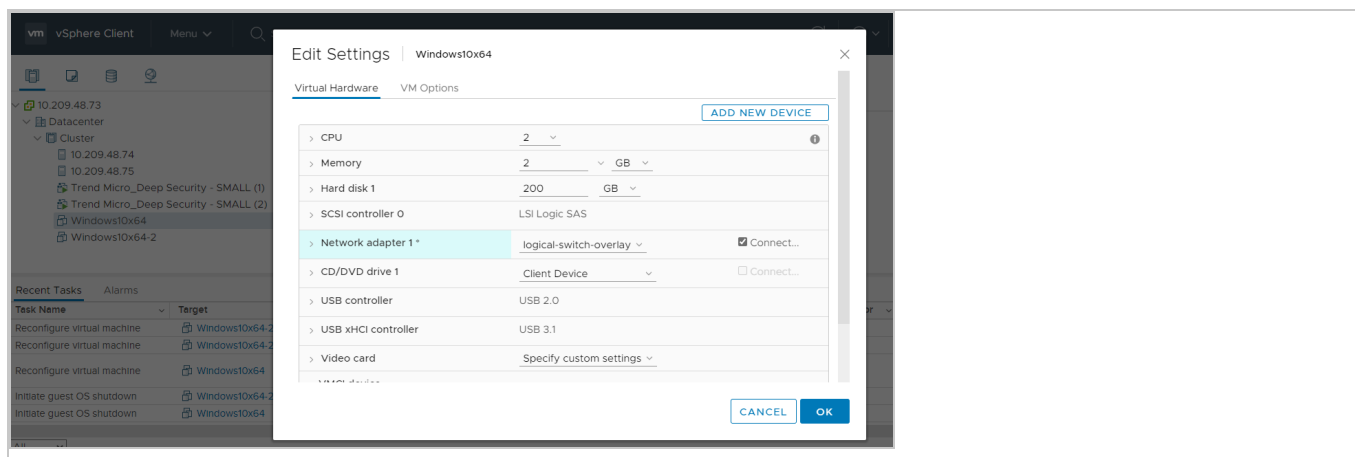

You have now configured east-west security in NSX-T.

Configure Endpoint Protection

Configuring Endpoint Protection is required in order to protect *existing* VMs with Deep Security Virtual Appliance's Anti-Malware feature.

Follow the steps below to configure a service profile for the Deep Security Virtual Appliance:

1. Still in NSX-T Manager, click **Security** at the top, select **POLICY** at the top, and then on the left, find **Endpoint Protection** and click **Endpoint Protection Rules**.
2. In the main pane, click **SERVICE PROFILES**.
3. From the **Partner Service** drop-down list, select **Trend Micro Deep Security** if it is not already selected.
4. Click **ADD SERVICE PROFILE** and fill out the fields as follows:
 - For the **Service Profile Name**, specify a name. Example: `dsva-service-profile-epp`.
 - For the **Service Profile Description**, enter a description. Example: `Deep Security Service Profile for Endpoint Protection`.
 - For the **Vendor Template**, select **Default (EBT)**. This template was loaded at the same time as the Trend Micro Deep Security service.

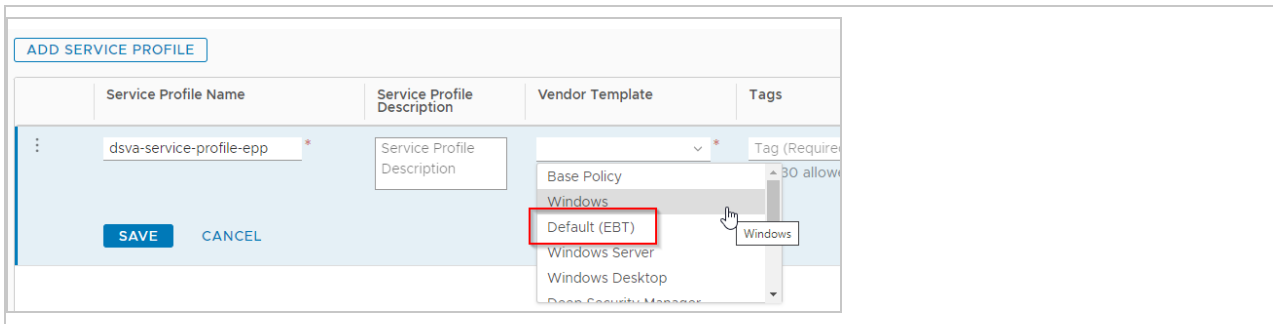

The **ADD SERVICE PROFILE** page should now look similar to the following:

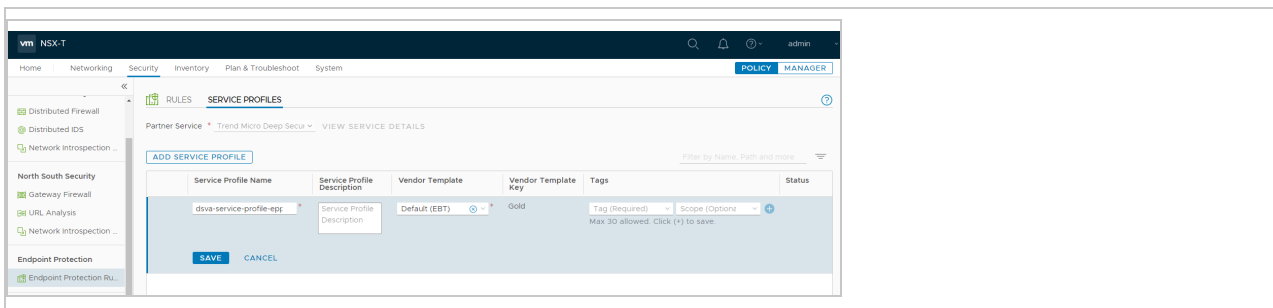

5. Click **SAVE**.
6. On the main pane, select the **RULES** tab and click **+ ADD POLICY**.
7. In the **Name** column, click within the **New Policy** cell and change the name. For example, use `dsva-policy-ep...`
8. Select the check box next to `dsva-policy-ep...` and click **+ ADD RULE**. A rule appears under `dsva-policy-ep...`
9. Name the rule and select the corresponding groups and service profiles. For example, name the rule `dsva-rule-ep...`, and select `dsva-protection-group` and `dsva-service-profile-ep...`. There is now a mapping between the VMs in the `dsva-protection-group` and the `Default (EBT)` template specified in the `dsva-service-profile-ep...`

The policy should now look similar to the following:

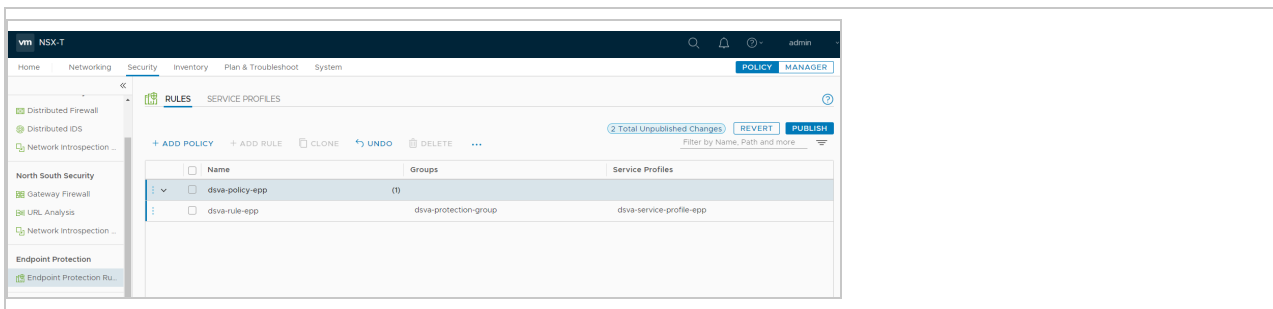

10. Click **PUBLISH** to finish the policy and rule creation.

You have now configured Endpoint Protection in NSX-T.

Configure activation

Topics:

- ["Prepare for activation" below](#)
- ["Trigger an activation and policy assignment" on page 588](#)
- ["Check that VMs are activated and assigned a policy" on page 588](#)

Prepare for activation

You must now prepare for activation. You can use Method 1, 2, or 3:

- ["Method 1: Create a 'Computer Created' event-based task" on the next page](#)
- ["Method 2: Create an 'NSX Security Group Change' event-based task" on page 583](#)
- ["Method 3: Synchronize your Deep Security policies to NSX-T 3.x" on page 586](#)

Not sure which method to choose? Here is some information to help:

- Some methods aren't supported with some NSX versions. Consult the table below for details.
 - Method 1: With this method, any VMs that you newly create in your system are automatically activated and assigned a policy.
 - Method 2: With this method, new and existing VMs are automatically activated and assigned a policy when they are moved into a designated NSX security group.
 - Method 3: With this method, new and existing VMs are activated and assigned a policy when they are moved into a designated NSX security group. This is similar to method 2. However, unlike method 2, Deep Security policies are assigned through the VMware UI instead of through a Deep Security event-based task.
-

Deep Security Virtual Appliance deployment									
	NSX for vSphere (NSX-V) 6.4.x								NSX-T 3.x
Method	Standard OR NSX for vShield Endpoint (free)	Advanced	Enterprise	NSX Data Center Standard	NSX Data Center Professional	NSX Data Center Advanced	NSX Data Center Enterprise Plus	NSX Data Center for Remote Office Branch Office	All license types
Method 1	✓	✓	✓	✓	✓	✓	✓	✓	✓
Method 2	X	✓ ¹	✓ ¹	X	X	✓ ¹	✓ ¹	✓ ¹	✓
Method 3	X	✓ ¹	✓ ¹	X	X	✓ ¹	✓ ¹	✓ ¹	✓

¹ Requires VMware's Network Introspection Service.

- Requires the following software combination: Deep Security Manager FR 2019-12-12 (build 12.5.494) or newer with Deep Security Agent Linux FR 2020-04-02 (build 12.5.0-814) or newer.

Method 1: Create a 'Computer Created' event-based task

Expand instructions

The instructions below are task-based. For more explanatory information on event-

based tasks, see ["Automated policy management in NSX environments"](#) on page 616.

1. In Deep Security Manager, click **Administration** at the top.
2. On the left, click **Event-Based Tasks**.
3. In the main pane, click **New**.
4. From the **Event** drop-down list, select **Computer Created (by System)**. Click **Next**.
5. Select **Activate Computer** and set it to 5 minutes.
6. Select **Assign Policy** and select a policy from the drop-down list, for example, **Windows Server 2016**. You can click the arrows to view child policies. Click **Next**.
7. Specify the conditions that restrict when the event-based task is triggered. Add this condition:

vCenter Name matches `<your_vCenter_name>`

8. Add more conditions to further restrict when the event-based task is triggered. For example, if you have a naming convention for your VMs that includes a 'Windows' prefix on all Windows VMs, you would set:

Computer Name matches `Windows*`

Click **Next**.

9. In the **Name** field, enter a name for the task that reflects the policy you assigned, for example, `Activate Windows Server 2016`.
10. Select **Task Enabled** and then click **Finish**.
11. Create additional event-based tasks, one per Deep Security policy you plan on assigning. The event-based task must have an event type of **Computer Created (by System)** and must be configured to activate the computer and assign a policy.

You have now set up your event-based tasks to activate and assign policies to newly-created VMs. As soon as a VM is created, all the **Computer Created (by System)** event-based tasks are reviewed. If the conditions in a task are met, the task is triggered, and the VM is activated and assigned the associated policy.

Method 2: Create an 'NSX Security Group Change' event-based task

Expand instructions

The instructions below are task-based. For more explanatory information on event-

based tasks, see "[Automated policy management in NSX environments](#)" on page 616.

To start, create or modify the **Activate** event-based task:

1. In Deep Security Manager, click **Administration** at the top.
2. On the left, click **Event-Based Tasks**.
3. In the main pane, look for the event-based task called **Activate <your_vCenter_name>**. It may or may not exist.
4. If the **Activate** event-based task exists, double-click it and review the table below make sure it is configured properly. If it doesn't exist, click **New** and run through the wizard, making sure to conform to the table below.
5. Create additional **Activate** event-based tasks if you added multiple vCenter servers to the manager.

Note: Settings in the table below may appear in a different order from shown.

To configure the 'Activate' event-based task, set...	To...
Name	A name for the task that reflects the action and vCenter assigned under Conditions , for example, <code>Activate your_vCenter_name</code> .
Event	NSX Security Group Change The NSX Security Group Change event is triggered when the manager receives a notification from the data plane (the Deep Security Virtual Appliance).
Task Enabled	Enabled.
Activate Computer	5 minutes.
Assign Policy	A policy, for example, Windows Desktop . You can click the arrows to view child policies.
Conditions	Mandatory condition to restrict when the event-based task is triggered:

To configure the 'Activate' event-based task, set...	To...
	<ul style="list-style-type: none"> • vCenter Name matches <code><your_vCenter_name></code> <p>Examples of optional conditions to further restrict triggering:</p> <ul style="list-style-type: none"> • Appliance Protection Available matches True. • Appliance Protection Activated matches False. • NSX Security Group Name matches <code>.+</code> (which means <i>any</i>)

Next, create or modify the **Deactivate** event-based task:

1. Still in Deep Security Manager, in the main pane, look for the event-based task called **Deactivate <your_vCenter_name>**. It may or may not exist.
2. If the **Deactivate** event-based task exists, double-click it and review the table below make sure it is configured properly. If it doesn't exist, click **New** and run through the wizard, making sure to conform to the table below.
3. Create additional **Deactivate** event-based tasks if you added multiple vCenter servers to the manager.

Note: Settings in the table below may appear in a different order from shown.

To configure the 'Deactivate' event-based task, set...	To...
Name	A name for the task that reflects the action and vCenter assigned under Conditions , for example, <code>Deactivate your_vCenter_name</code> .
Event	<p>NSX Security Group Change</p> <p>The NSX Security Group Change event is triggered when the manager receives a notification from the data plane (the Deep Security Virtual Appliance).</p>

To configure the 'Deactivate' event-based task, set...	To...
Task Enabled	Enabled.
Deactivate Computer	Enabled.
Conditions	<ul style="list-style-type: none"> • Appliance Protection Activated matches True. • NSX Security Group Name matches <code>^\$</code> (which means <i>none</i>) • vCenter Name matches <code><your_vCenter_name></code>

You have now set up your event-based tasks to activate your VMs. If the conditions in a task are met, the task is triggered, and the VM is activated (and assigned the associated policy).

Method 3: Synchronize your Deep Security policies to NSX-T 3.x

Expand instructions

The instructions below are task-based. For more explanatory information on synchronizing policies, see ["Synchronize Deep Security policies with NSX" on page 621](#).

To start, configure Deep Security Manager:

1. Log in to Deep Security Manager.
2. Make sure that all of the policies in Deep Security Manager have a unique name before they are synchronized with NSX. All the default ones have unique names.
3. At the top, click **Computers**.
4. On the left, right-click the vCenter where you want to enable synchronization and select **Properties**.
5. On the **NSX Configuration** tab, select **Synchronize Deep Security Policies with NSX Service Profiles**. Click **OK**.

Next, check that your policies are loading into NSX-T Manager:

1. In NSX-T Manager, click **Security** at the top, switch to the **POLICY** mode.
2. On the left, find **Settings** and click **Network Introspection Settings**.
3. In the main pane, click **SERVICE PROFILES** and from the **Partner Service** drop-down list, select **Trend Micro Deep Security**.
4. Click **ADD SERVICE PROFILE**.
5. Check the **Vendor Template** drop-down list. Your Deep Security policies should appear in this list in the format `<Deep_Security_Policy_Name>_Network`.
6. You have now checked that your policies are loading.
7. Click **Cancel** to return to the main page.

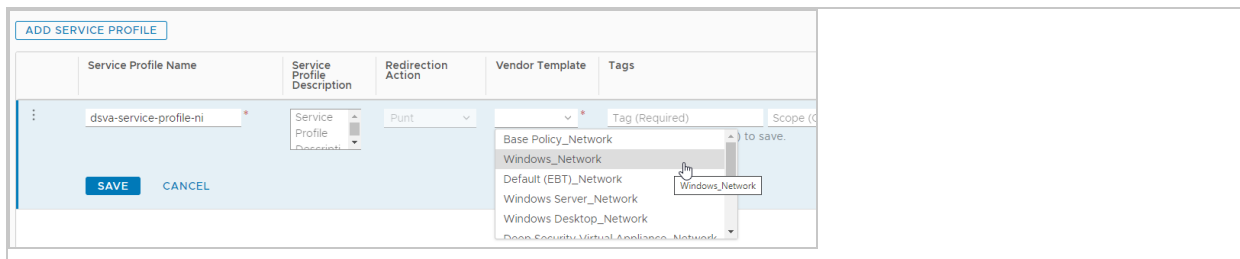

You have now added your Deep Security policies as vendor templates in NSX.

Finally, reconfigure east-west security and Endpoint Protection:

1. Go back to ["Create a group for protection" on page 573](#) and run through the steps again to create more groups. For example, `Windows_Group`.
2. Go back to ["Configure east-west security" on page 575](#) and run through the steps again, this time selecting one of the Deep Security policies from **Vendor Template** (instead of **Default (EBT)_Network**) and selecting one of the new groups.
3. Go back to ["Configure Endpoint Protection" on page 579](#) and run through the steps again, this time selecting one of the Deep Security policies from **Vendor Template** (instead of **Default (EBT)**) and selecting one of the new groups. The policy and group must match the one use for east-west security.

Warning: Make sure to match the template under east-west security and Endpoint Protection for a particular group. For example, if you select **MyWindowsPolicy_Network** under east-west security, select **MyWindowsPolicy** under Endpoint Protection.

You have now set up policy synchronization to activate VMs, including existing and newly-created ones.

Trigger an activation and policy assignment

Your VMs are now ready to be activated and assigned a policy.

- If you chose Method 1, you'll need to manually synchronize the vCenter. Go to Deep Security Manager, right-click the vCenter on the left, and select **Synchronize Now**. Your existing VMs should now be protected.
- If you chose Method 2 or 3, all VMs should be activated and assigned policy automatically now. To check, see the next step.

Check that VMs are activated and assigned a policy

You must now check that VMs were activated and assigned a policy successfully.

To check:

1. In Deep Security Manager, click **Computers** at the top.
2. On the left, expand **Computers > <your_vCenter> > Virtual Machines**.
3. Check the **TASK(S)** and **STATUS** and columns. (Click **Columns** at the top to add them if they are not visible.) The **TASK(S)** column should indicate **Activating**, and your VMs should move from the **Unmanaged (Unknown)** status, to the **Unmanaged (No Agent)** status, to the **Managed (Online)** status. You may see the VMs move into the **VMware Tools Not Installed** status, but this is temporary.
4. Check the **POLICY** column to make sure the correct Deep Security policy was assigned.

You have now deployed Deep Security Virtual Appliance and protected your VMs with it.

Next steps (how to add new VMs)

After deploying the appliance, you may need to add new VMs.

Follow the instructions below to learn how to add new VMs to your system and protect them with Deep Security.

To add a new VM if you chose Method 1 (create a 'Computer Created' event-based task):

- Create a new VM in vCenter. This triggers the **Computer Created (by System)** event-based task, which activates and assigns policy to the new VM.

To add a new VM if you chose Method 2 (create an 'NSX Security Group Change' event-based task):

- Create or move the VM into one of the NSX security groups. This triggers the **NSX Security Group Change** event-based task, which activates and assigns policy to the new VM.

To add a new VM if you chose Method 3 (synchronize Deep Security policies to NSX):

- Create or move the VM into one of the NSX security groups. This activates and assigns policy to the new VM.

Deploy the appliance (NSX-V)

After completing the tasks in ["Before deploying the appliance" on page 551](#), you are ready to deploy the appliance on NSX Data Center for vSphere (NSX-V). Follow the steps below.

- ["Step 1: Import the appliance package into Deep Security Manager" below](#)
- ["Step 2: Add vCenter to Deep Security Manager" on the next page](#)
- ["Step 3: Prepare ESXi servers" on the next page](#)
- ["Step 4: Install Guest Introspection" on page 592](#)
- ["Step 5: Install the Deep Security Virtual Appliance on NSX-V" on page 595](#)
- ["Step 6: Create an NSX security group and policy" on page 596](#)
- ["Step 7: Prepare for activation on NSX-V" on page 604](#)
- ["Step 8: Trigger an activation and policy assignment" on page 611](#)
- ["Step 9: Check that VMs are activated and assigned a policy" on page 611](#)
- ["Next steps \(how to add new VMs\)" on page 611](#)

You can also ["Upgrade the appliance" on page 1637](#) to protect against new OS vulnerabilities.

Step 1: Import the appliance package into Deep Security Manager

After completing the tasks in ["Before deploying the appliance" on page 551](#), you are ready to import the appliance ZIP into Deep Security Manager.

Tip: As an alternative to importing the appliance ZIP, you can place the OVF file at a URL location to make it faster for NSX to download. For details, see ["Configure the appliance OVF location" on page 626](#).

1. Go to:

<https://help.deepsecurity.trendmicro.com/software.html>

2. Download the Deep Security Virtual Appliance package. Check the version requirements in [system requirements](#).

You can import multiple versions of the appliance. The manager will choose the newest package.

3. On Deep Security Manager, go to **Administration > Updates > Software > Local**.

4. Click **Import** and upload the package to Deep Security Manager.

On import, Deep Security Manager *also* automatically downloads and imports an agent that is compatible with the operating system of the virtual appliance VM. This agent has the same protection modules as Deep Security Agent for 64-bit Red Hat Enterprise Linux.

5. If you want to specify a different embedded agent, go to **Administration > System Settings > Updates** and look for **Virtual Appliance Deployment**. By default, the **Virtual Appliance Deployment** option is set to **Latest Available (Recommended)**. This indicates to the manager to upgrade the virtual appliance to use the newest imported, embedded agent. Change this setting, as required.

Step 2: Add vCenter to Deep Security Manager

Follow the instructions in "[Add a VMware vCenter](#)" on page 681.

After you have finished:

- your guest VMs are displayed in Deep Security Manager.
- the Trend Micro Deep Security service is registered with NSX-T.

Step 3: Prepare ESXi servers

If you are using NSX Advanced Edition or NSX Enterprise Edition, you must prepare your ESXi servers by installing the drivers necessary for network traffic inspection. This operation is performed on the cluster.

If you are using another NSX edition, skip this section.

1. In your vSphere Web Client, go to **Home > Networking & Security > Installation > Host Preparation**:

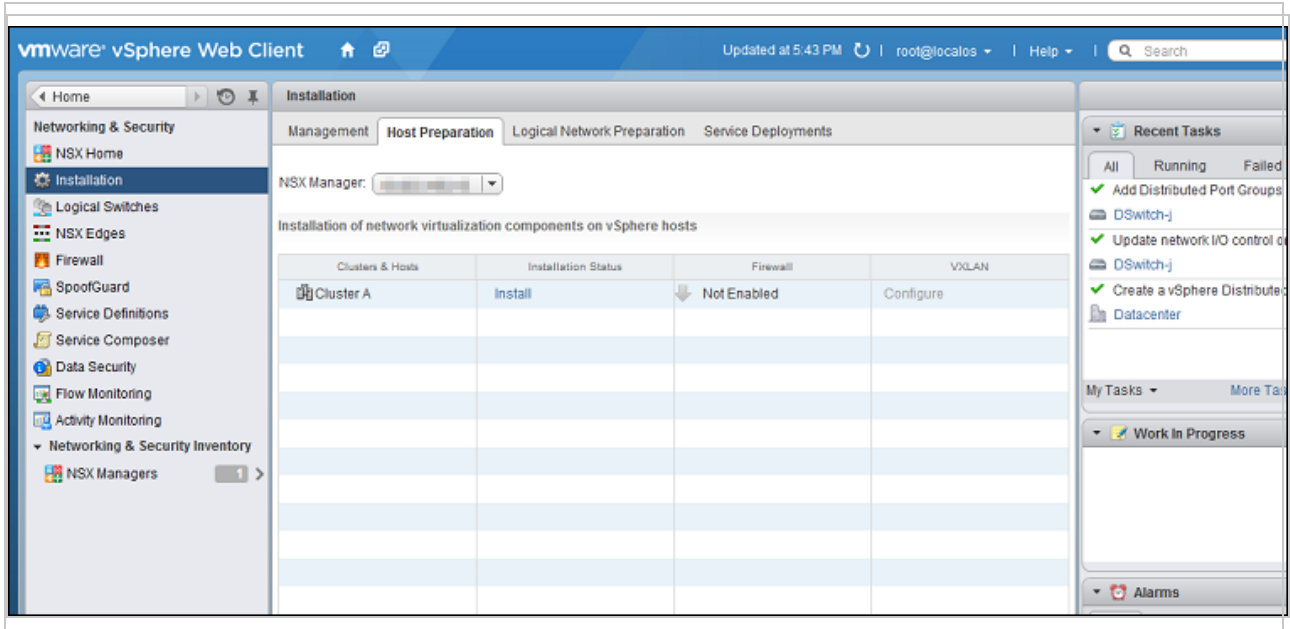

2. Locate the NSX cluster you are going to protect with Deep Security in the **Clusters & Hosts** list and click **Install** in the **Installation Status** column. The installation will complete and the driver version will be displayed in the **Installation Status** column:

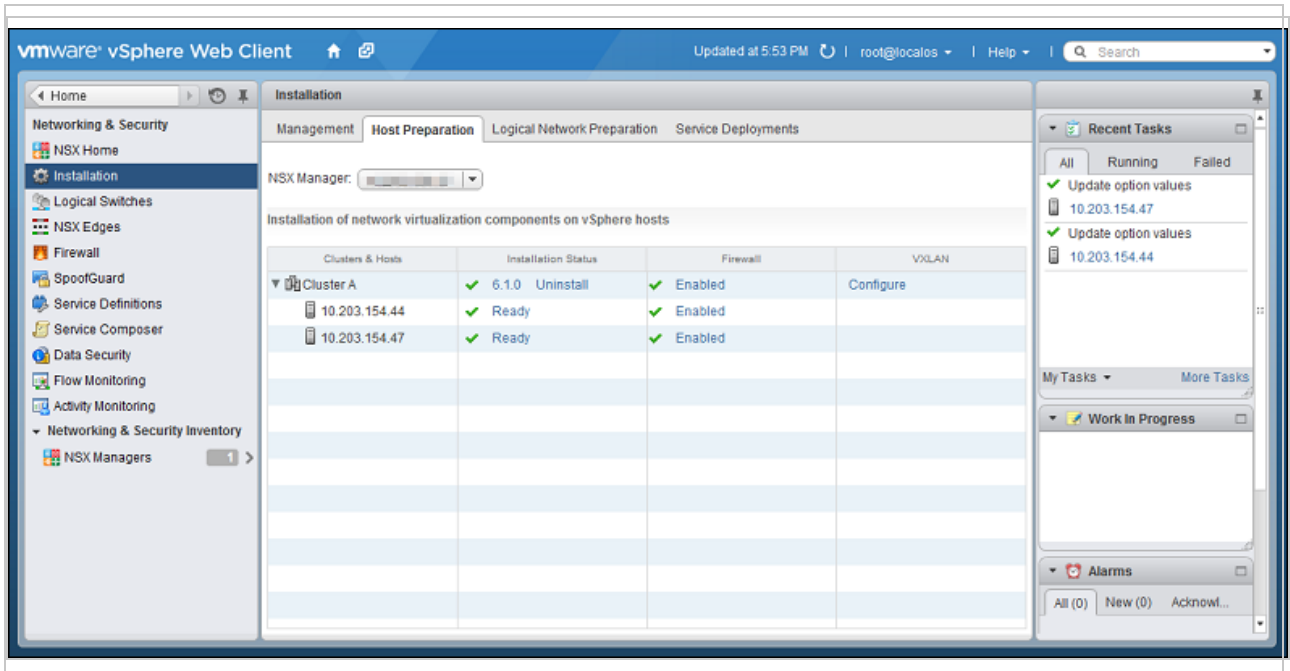

ESXi host preparation is now complete. For more complete instructions on host preparation, see VMware documentation.

Step 4: Install Guest Introspection

If you want file-based protection such as Anti-Malware or Intrusion Prevention for your VMs, you must install the Guest Introspection service on your ESXi servers.

The Guest Introspection service consists of a couple of drivers: the File Introspection (vsepflt) driver and Network Introspection (vnetflt) driver.

Warning: If you do not install Guest Introspection, the Anti-Malware and Intrusion Prevention features will not work.

1. In vSphere Web Client, go to **Home > Networking & Security > Installation**, then click the **Service Deployments** tab.

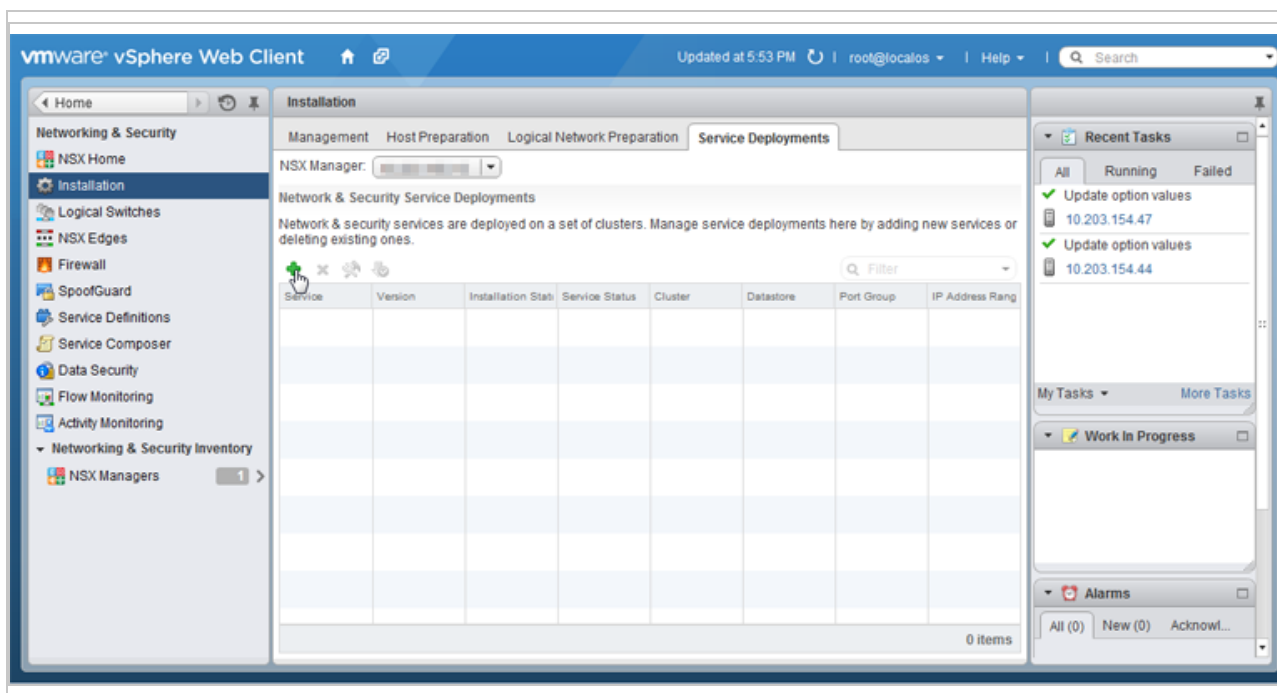

2. Click the green plus icon (+).

The **Deploy Network & Security Services** window appears.

3. Select **Guest Introspection**, then click **Next**.

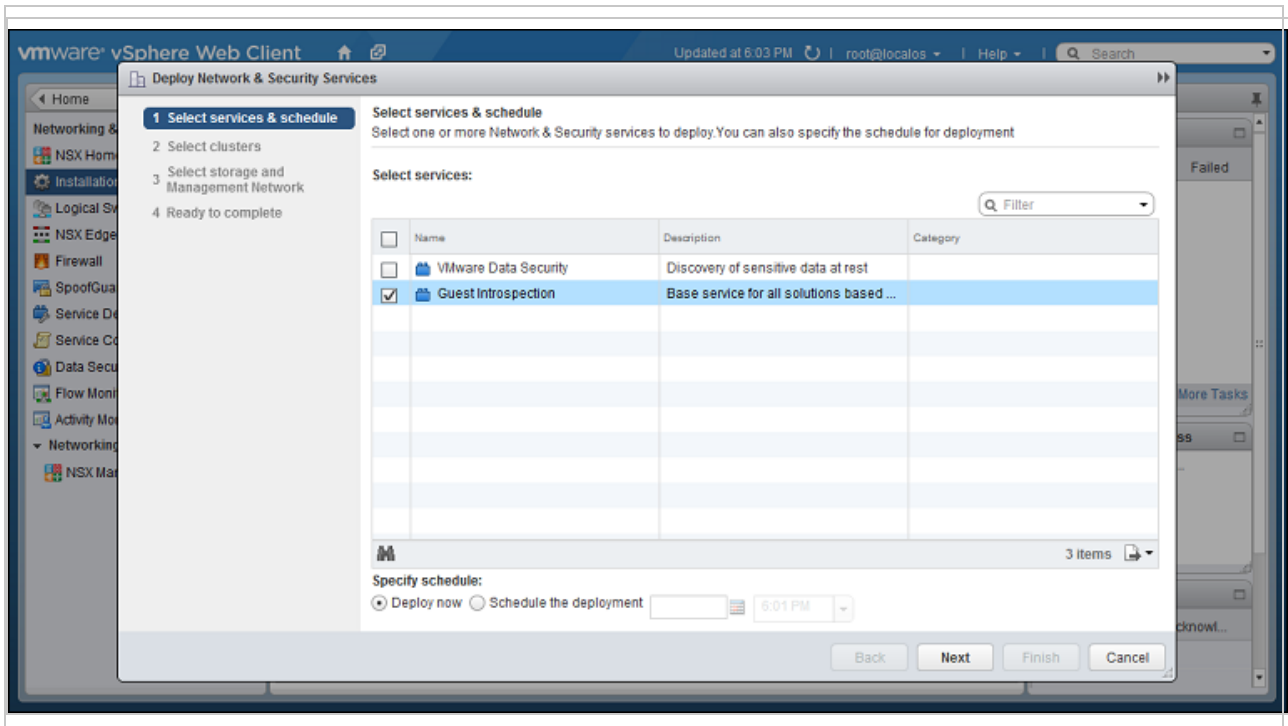

4. Select the cluster that contains the ESXi servers and VMs that you want to protect, then click **Next**.

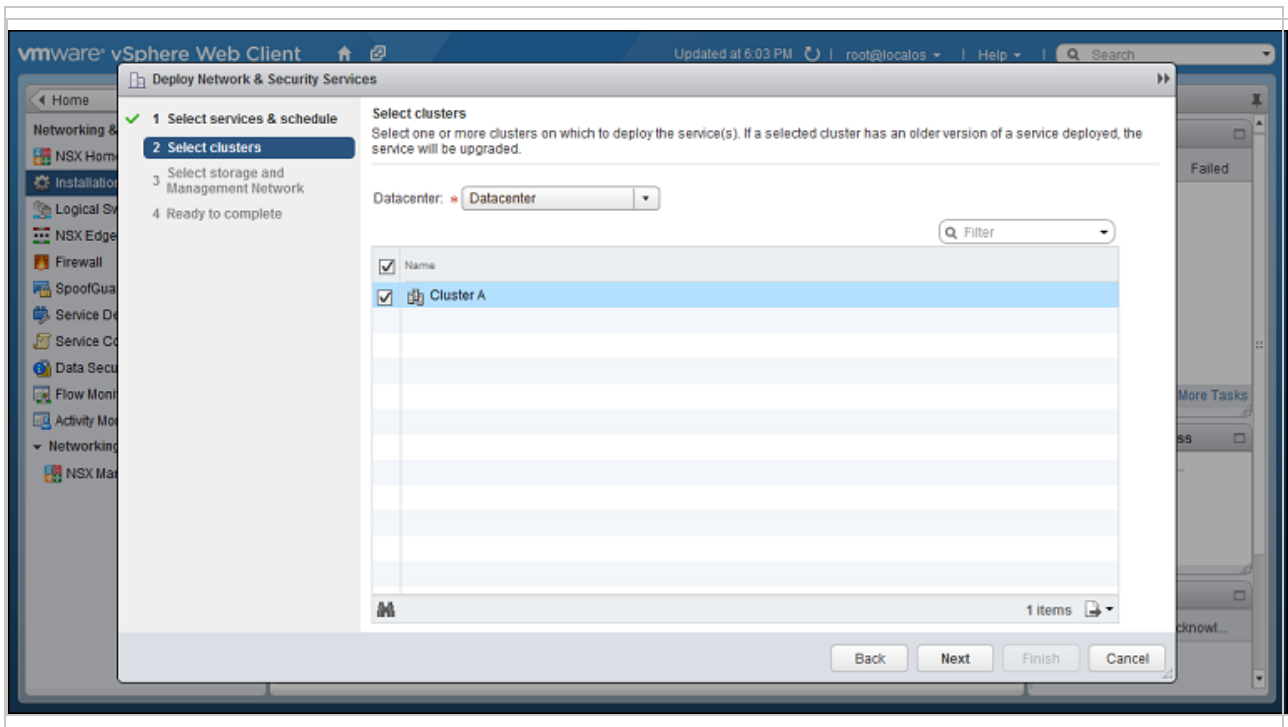

5. Select the datastore, the distributed port group used by your NSX cluster, and IP

assignment method, then click **Next**.

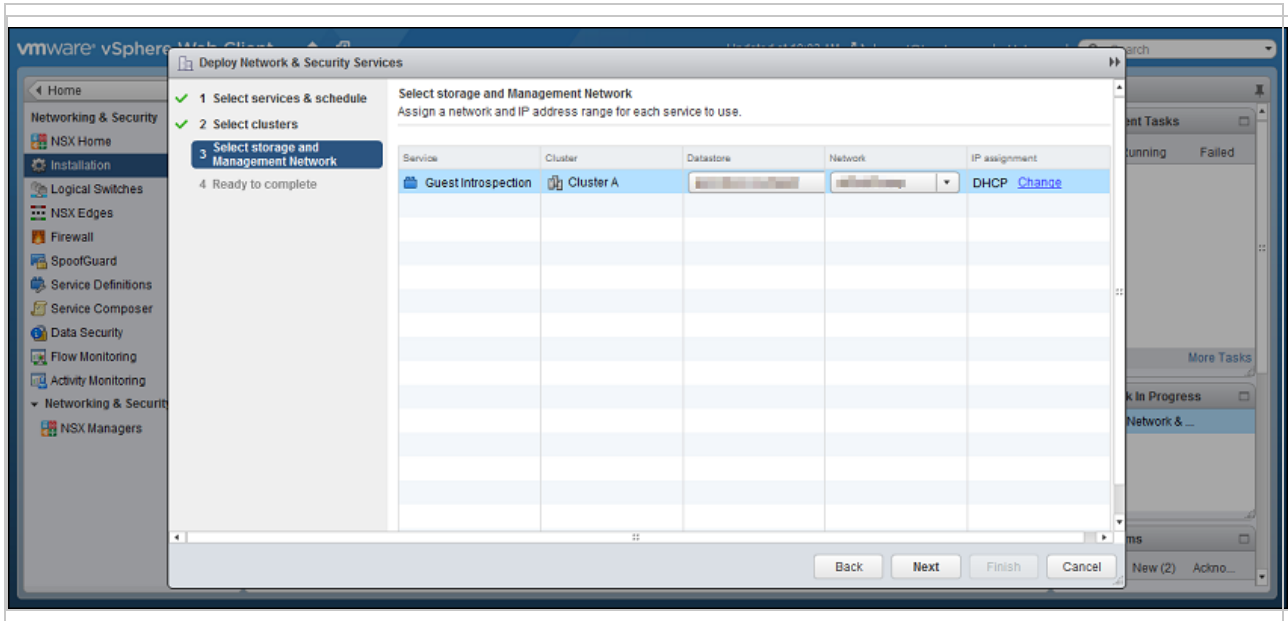

6. Review your settings, then click **Finish**.

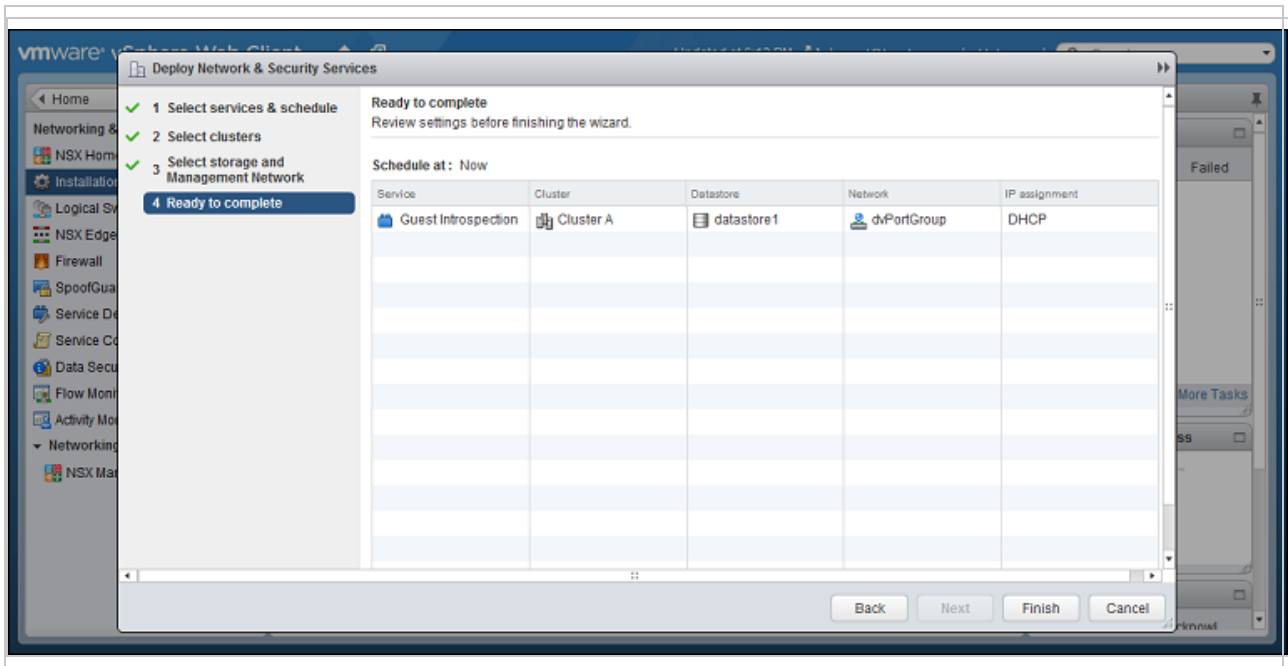

vSphere may take a few minutes to install the guest introspection service on your ESXi servers. When it is finished, **Installation Status** will display "Succeeded". To update the status, you may need to refresh the vSphere Web Client.



Step 5: Install the Deep Security Virtual Appliance on NSX-V

1. In the vSphere Web Client, go to **Home > Networking and Security > Installation > Service Deployments**.
2. Click the green plus sign (+).

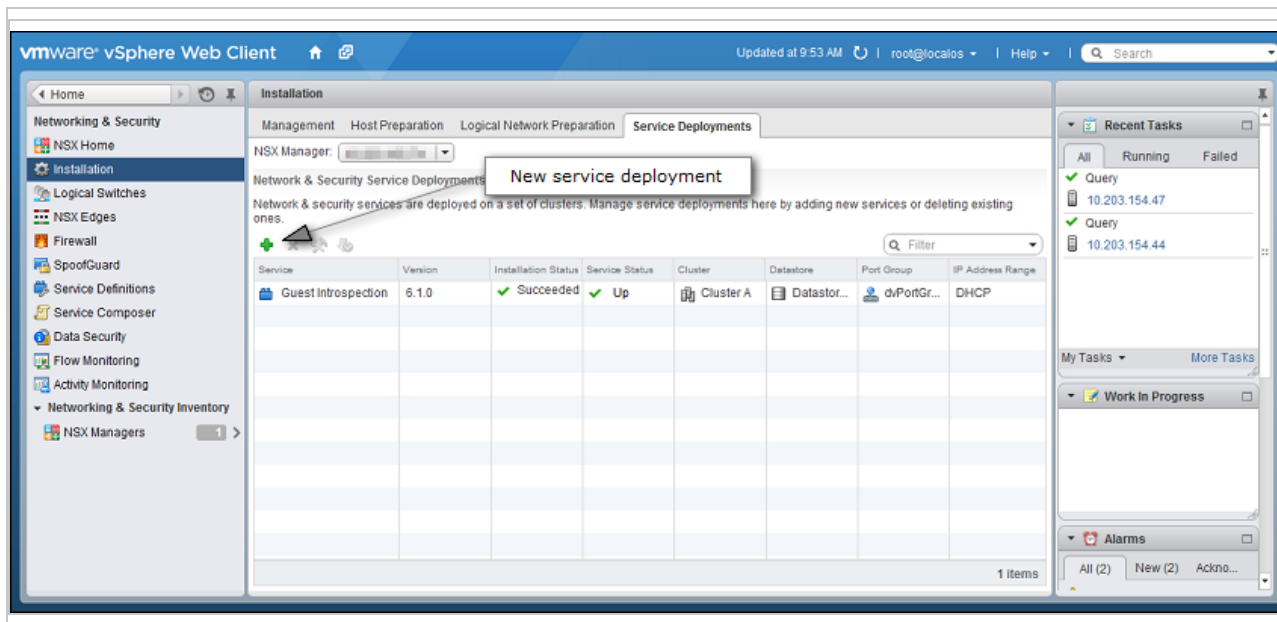

3. In the new window that appears, select the **Trend Micro Deep Security** service and then click **Next**. If you do not see this service, it might be because you have not yet added your vCenter to Deep Security Manager. For details, see ["Step 2: Add vCenter to Deep Security Manager"](#) on page 590.

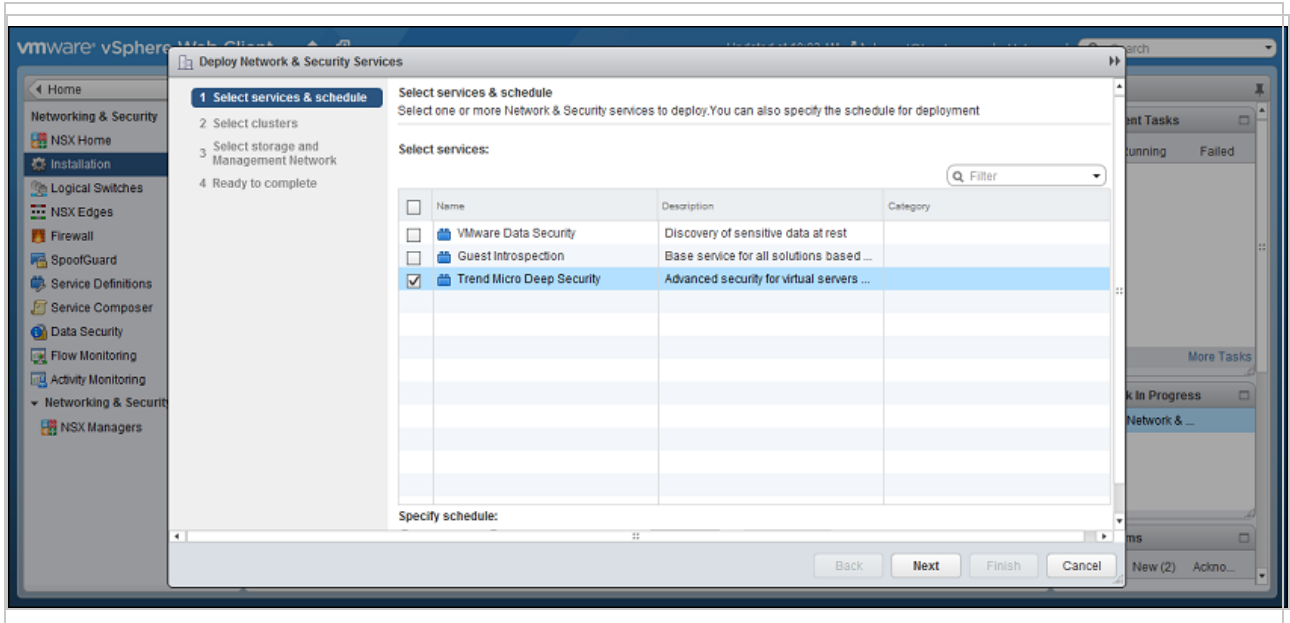

4. Click **Finish**.

When deployment is complete, the Trend Micro Deep Security service appears in the list of network and security service deployments in the cluster.

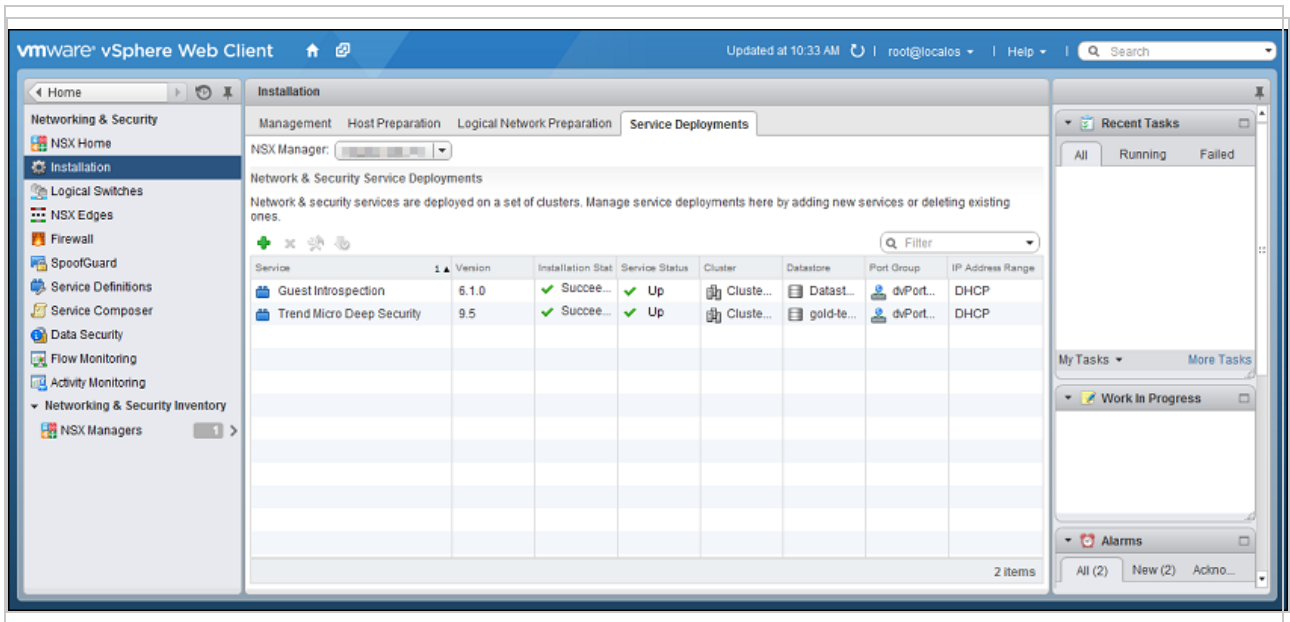

Step 6: Create an NSX security group and policy

To start, create an NSX security group that will contain the VMs you want to protect with the Deep Security Virtual Appliance:

1. In vSphere Web Client, go to **Home > Networking & Security > Service Composer > Security Groups**.
2. Click **New Security Group** (📁):

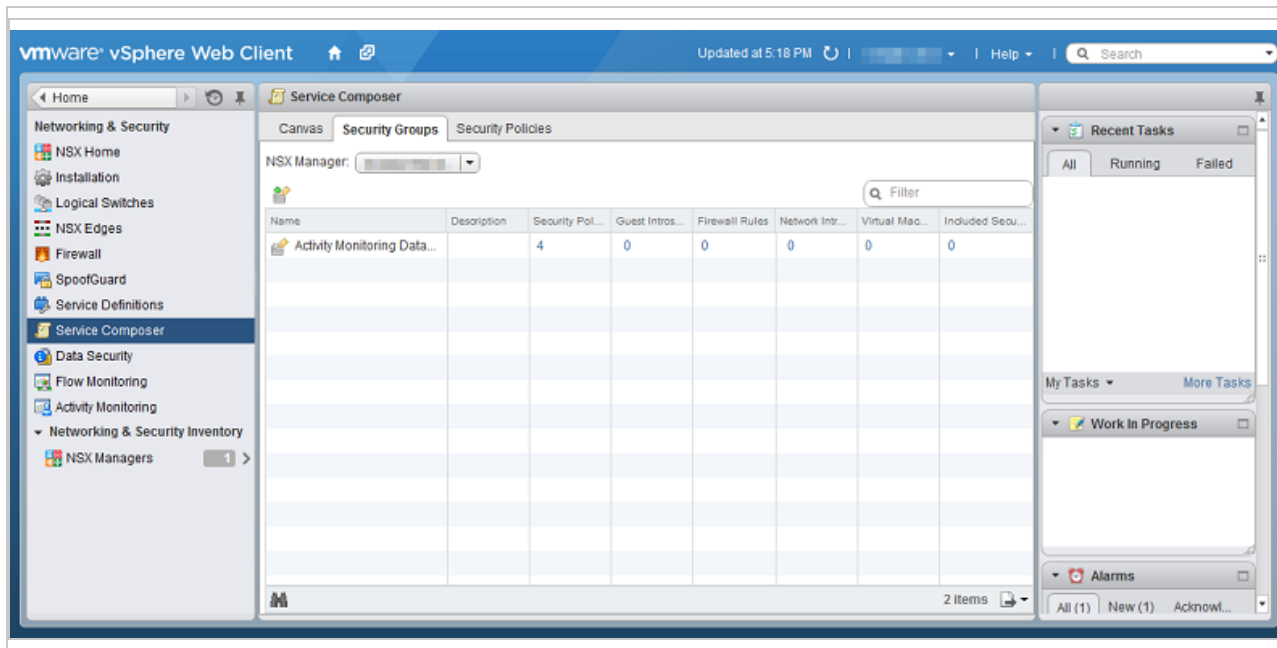

3. **Define Dynamic Membership:** If you want to restrict membership in this group based on filtering criteria, enter those criteria here.

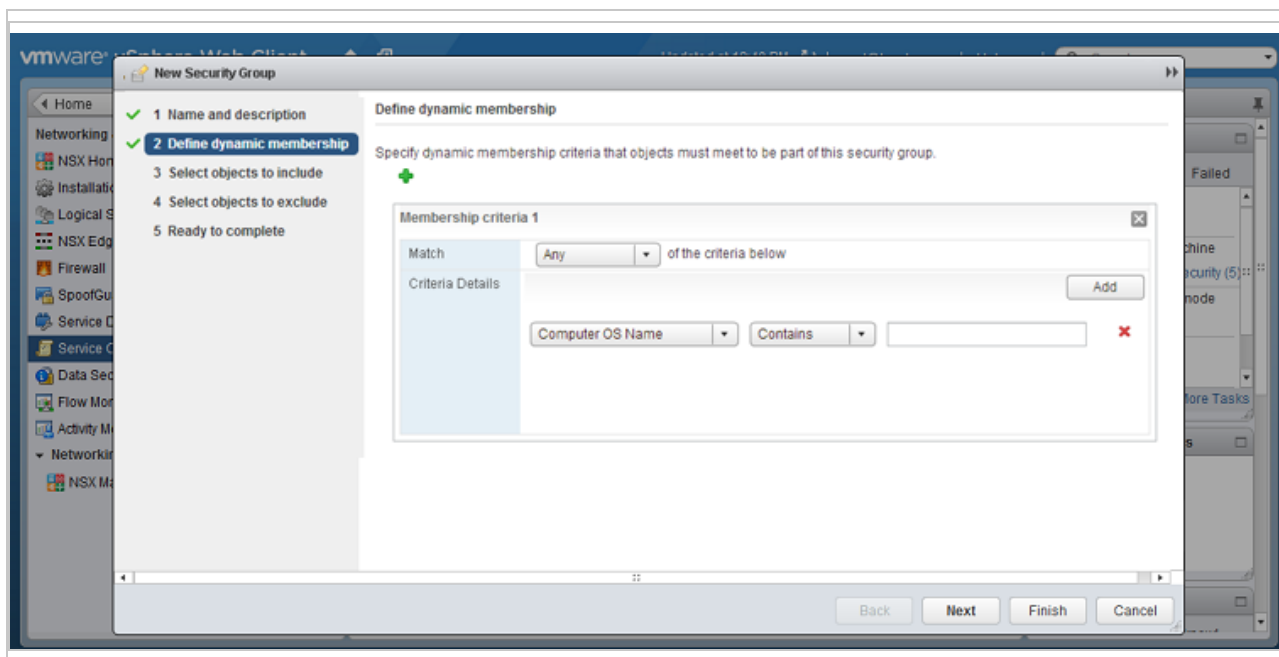

4. Select the objects that will be included.

There are many ways to include or exclude objects in a NSX security group. For this example, we will include the NSX cluster that contains the ESXi hosts and VMs that we want to protect. In the **Select objects to include** options, select **Cluster** from the **Object Type** menu, and move the NSX cluster that contains the VMs to protect to the **Selected Objects** column.

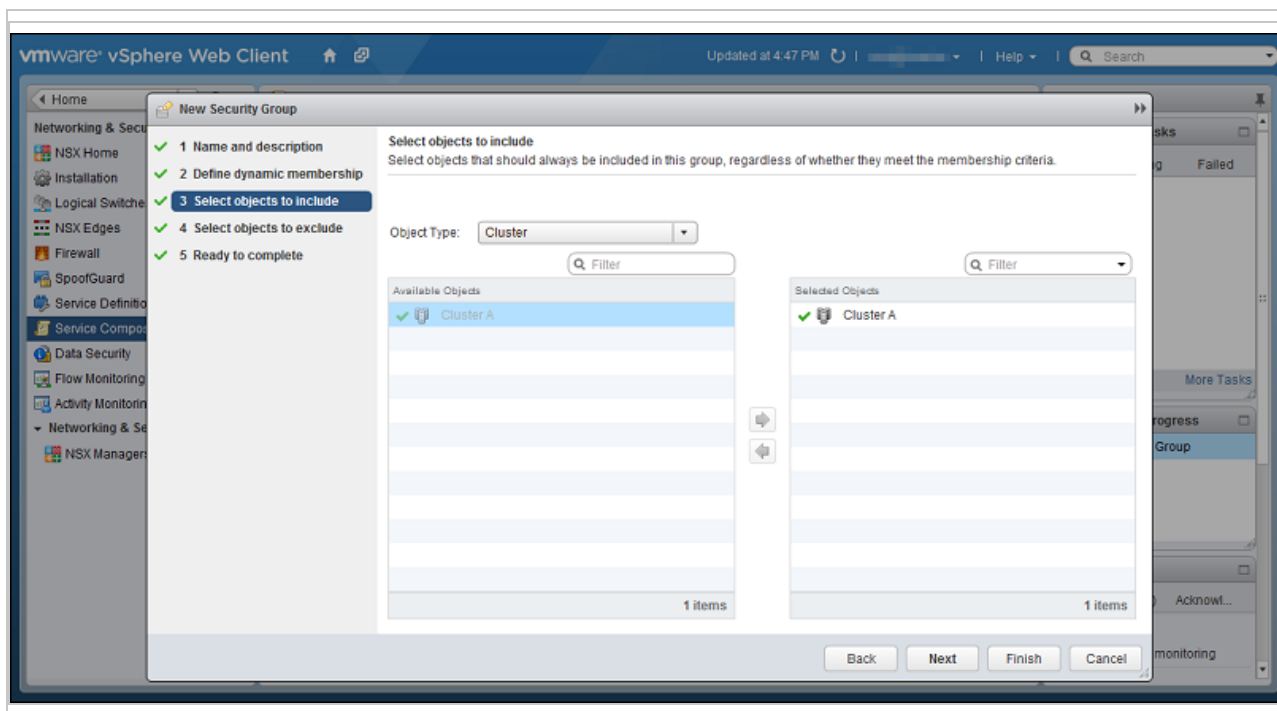

Note: If a VM is included in more than one security group, then when you go to **Computers** in Deep Security Manager and search for the VM's name, it will appear more than once in search results. For more information, please see [Duplicate host records appear in Computer page when the host is located in more than one NSX security group](#).

5. Click **Finish** to create the new security group and return to the **Security Groups** tab to see the newly listed security group.

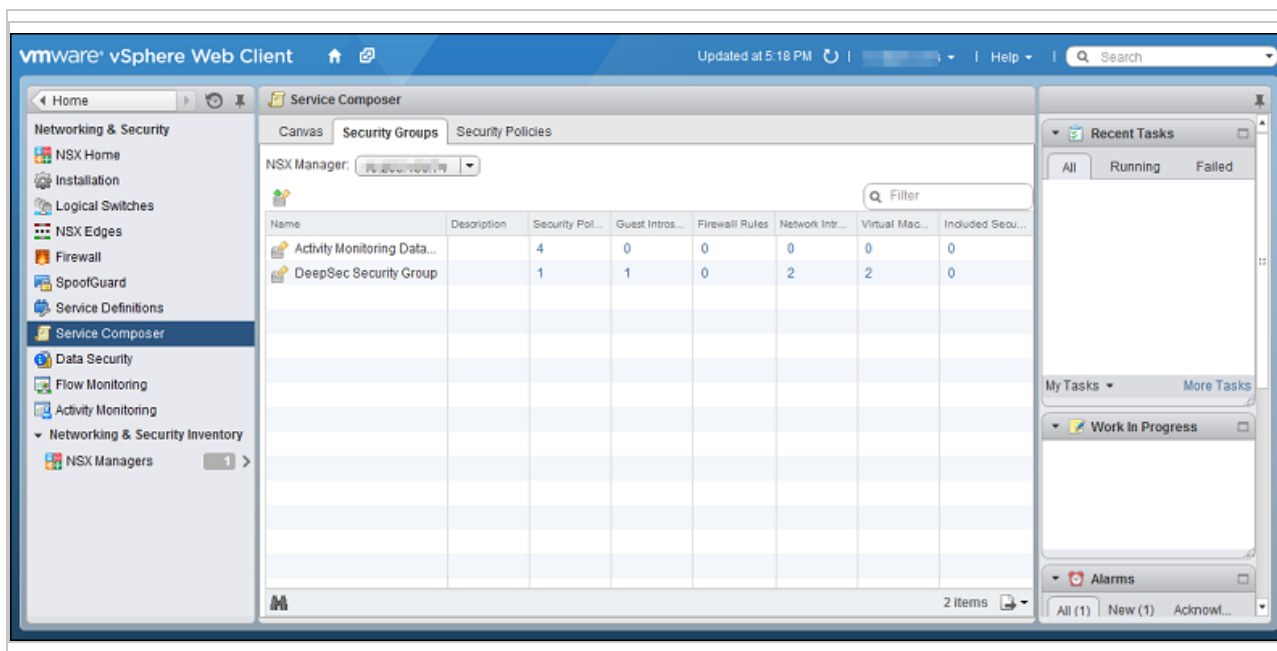

Next, create an NSX security policy:

1. In vSphere Web Client, go to **Home > Networking and Security > Service Composer > Security Policies**.
2. Click **New Security Policy**.

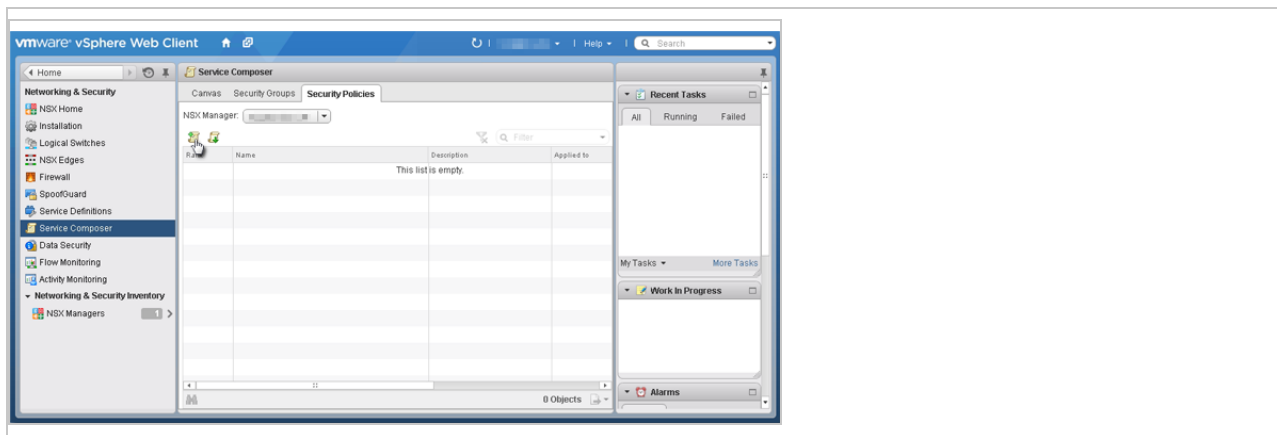

3. **Guest Introspection Services:** Configure Guest Introspection Services if you are using the Anti-Malware or Intrusion Prevention modules.

Warning: If you do not install Guest Introspection, the Anti-Malware and Intrusion Prevention features will not work.

Click the green plus sign (+) to add an **Endpoint Service**. Provide a name for the Endpoint Service and select the following settings:

- **Action:** Apply
- **Service Name:** Trend Micro Deep Security
- **Service Profile:** Select **Default (EBT)**. This is a profile configuration that is configured to trigger event-based task(s) in Deep Security Manager.
- **State:** Enabled
- **Enforce:** Yes

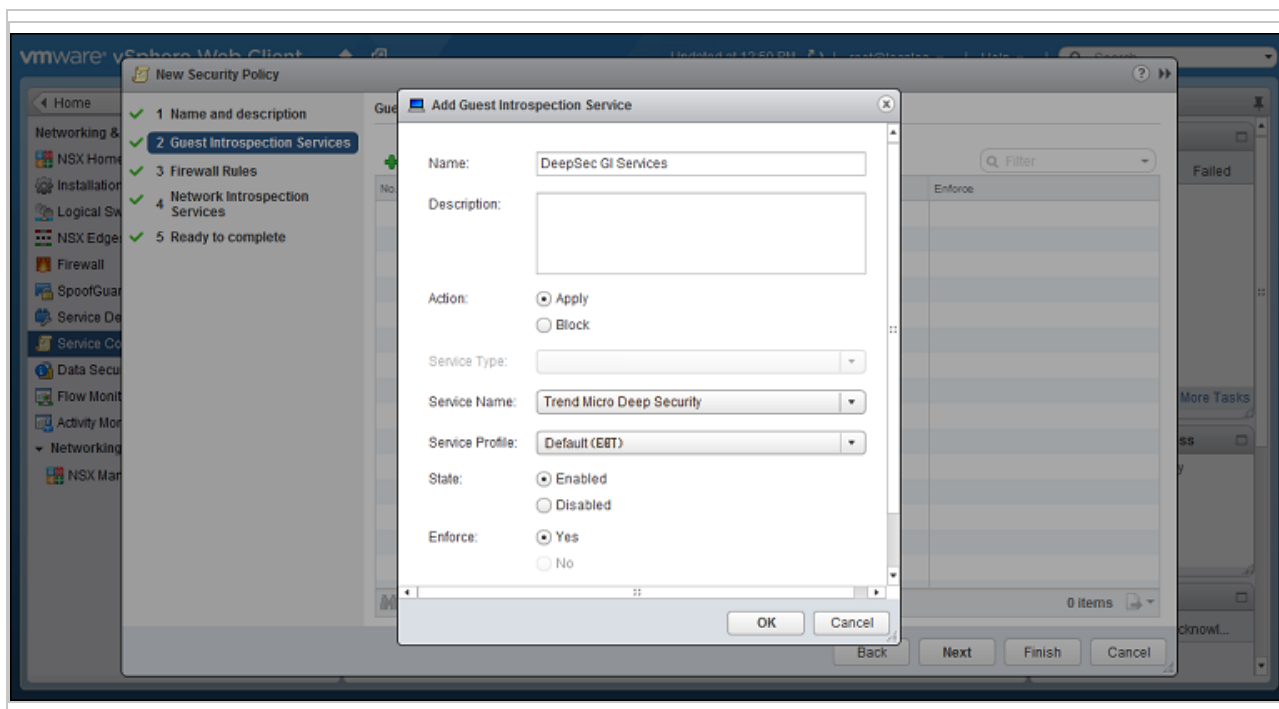

Click **OK**, then click **Next**.

4. **Firewall Rules:** do not make any changes. Click **Next**.
5. **Network Introspection Services:** Network Introspection Services are only available with NSX Advanced and Enterprise, and only need to be configured if you are using the Web Reputation, Firewall, or Intrusion Prevention modules. You will be adding *two* Network Introspection Services to the NSX Security Policy: a first one for *outbound* traffic, and a second one for *inbound* traffic.
 - a. For the first, *outbound*, service, in the **Network Introspection Services** options, click the green plus sign to create a new service. In the **Add Network Introspection Service** window, provide a name for the service (preferably one that includes the word "Outbound") and select the following settings:

- **Action:** Redirect to service
- **Service Name:** Trend Micro Deep Security
- **Service Profile:** Select **Default (EBT)**
- **Source:** Policy's Security Groups
- **Destination:** Any
- **Service:** Any
- **State:** Enabled
- **Log:** Do not log

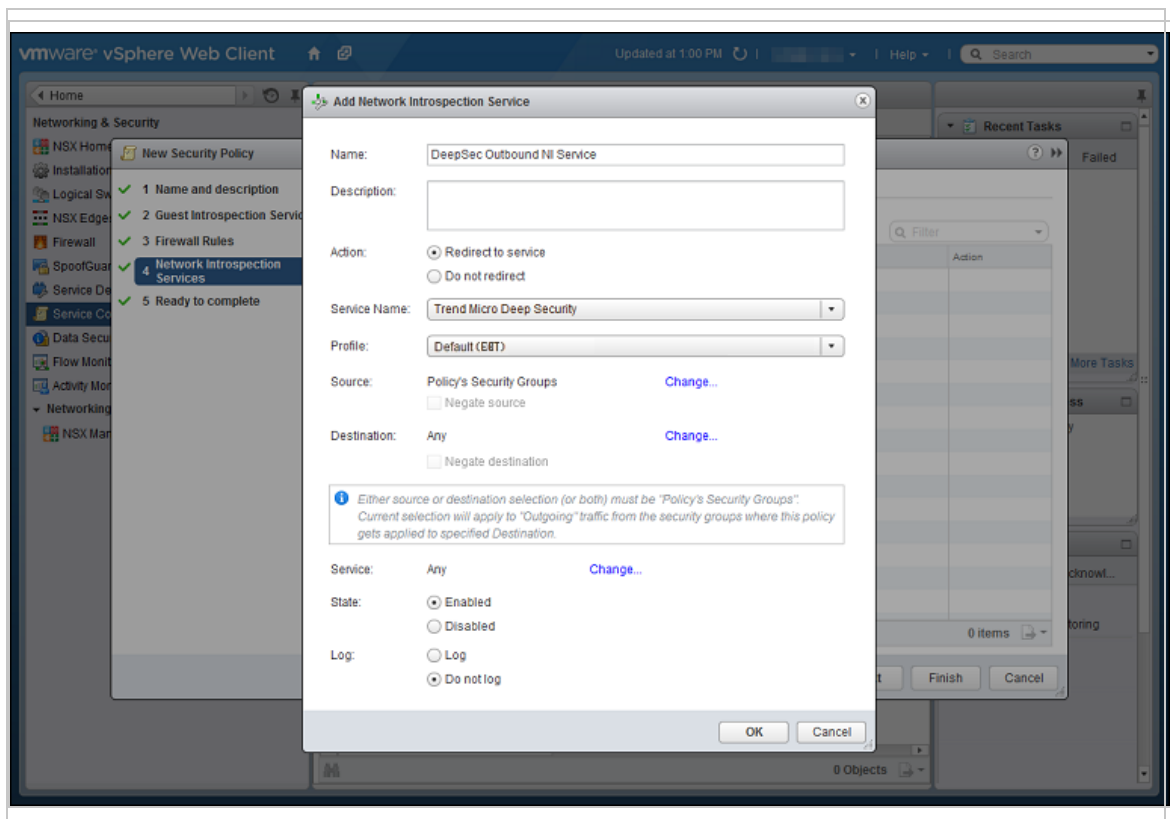

- b. For the second, *inbound*, service, in the **Network Introspection Services** options, click the green plus sign to create a new service. In the **Add Network Introspection Service** window, provide a name for the service (preferably one that includes the word "Inbound") and select the following settings:
- **Redirect to service:** Yes
 - **Service Name:** Trend Micro Deep Security
 - **Service Profile:** Select **Default (EBT)**

- **Source:** Any
- **Destination:** Policy's Security Groups
- **Service:** Any
- **State:** Enabled
- **Log:** Do not log

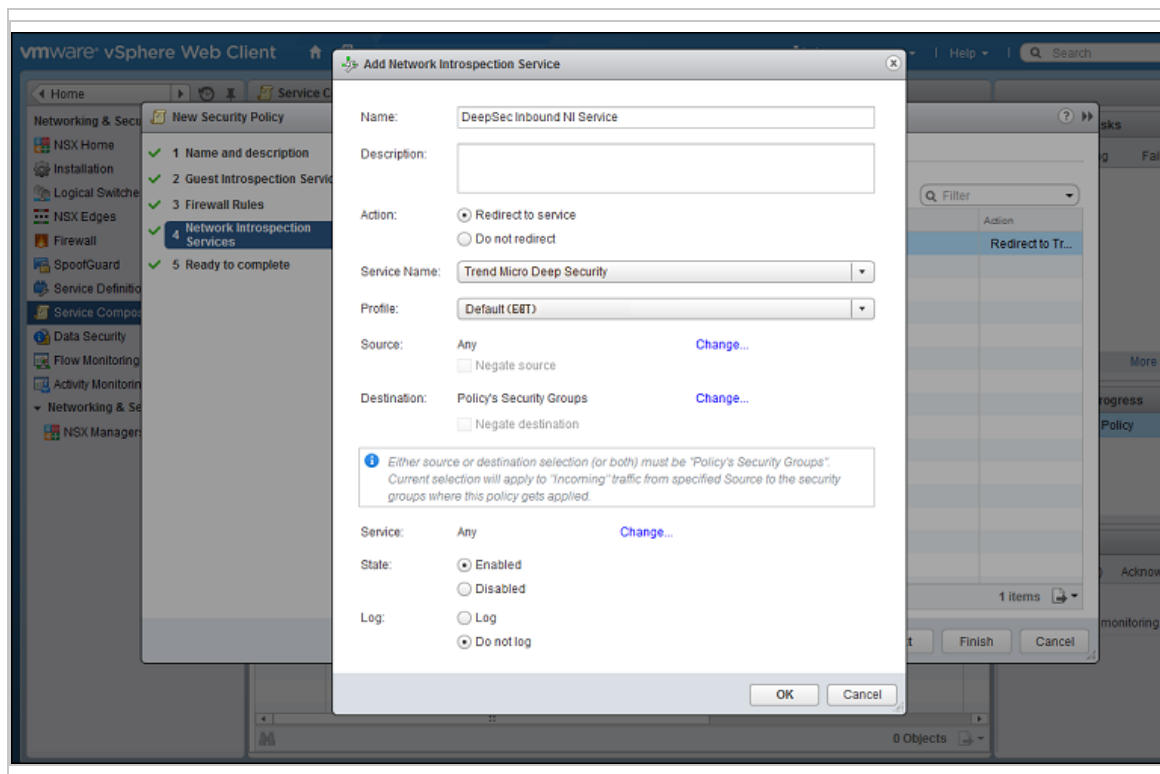

- c. Click **OK** in the **Add Network Inspection Service** window, and then click **Finish** to complete and close the **New Security Policy** window.

You have now created an NSX security policy for Deep Security.

Finally, associate the NSX security policy you just created with the NSX security group you also just created:

1. Stay on the **Security Policies** tab of the **Home > Networking & Security > Service Composer** page in your vSphere Web Client.
2. With the new security policy selected, click the **Apply Security Policy** icon (🏠).
3. In the **Apply Policy to Security Groups** window, select the security group that contains the VMs you want to protect and click **OK**.

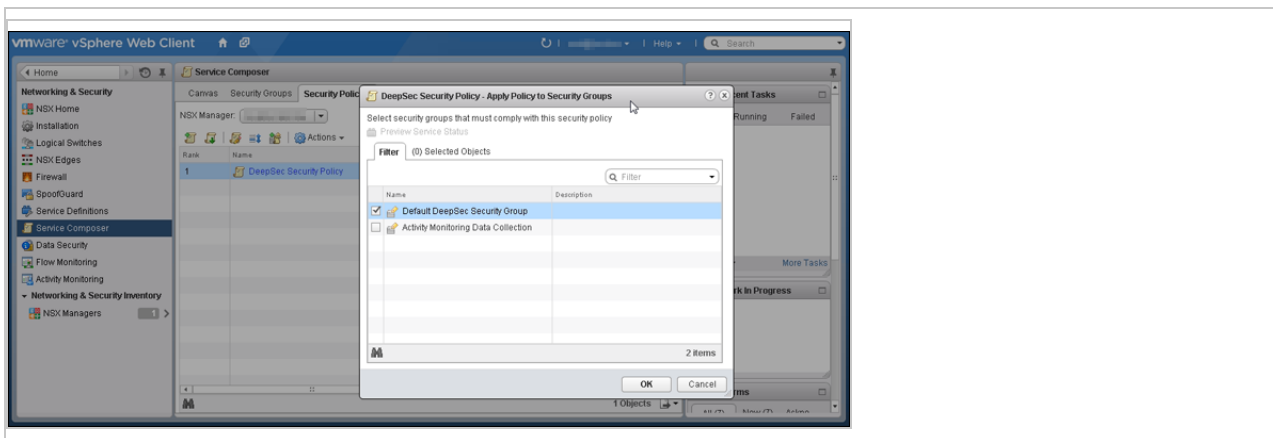

The NSX security policy is now applied to the VMs in the NSX security group.

You have now created NSX security groups and policies. Any VMs that are added to these NSX security groups will be activated in Deep Security Manager, and assigned a Deep Security policy.

Step 7: Prepare for activation on NSX-V

To prepare for activation, you can use Method 1, 2, or 3:

- ["Method 1: Create a 'Computer Created' event-based task" on the next page](#)
- ["Method 2: Create an 'NSX Security Group Change' event-based task" on page 606](#)
- ["Method 3: Synchronize your Deep Security policies to NSX-V" on page 609](#)

Not sure which method to choose? Here is some information to help:

- Some methods aren't supported with some NSX versions. Consult the table below for details.
- Method 1: With this method, any VMs that you newly create in your system are automatically activated and assigned a policy.
- Method 2: With this method, new and existing VMs are automatically activated and assigned a policy when they are moved into a designated NSX security group.
- Method 3: With this method, new and existing VMs are activated and assigned a policy when they are moved into a designated NSX security group. This is similar to method 2. However, unlike method 2, Deep Security policies are assigned through the VMware UI instead of through a Deep Security event-based task.

Deep Security Virtual Appliance deployment									
	NSX for vSphere (NSX-V) 6.4.x								NSX-T 3.x
Method	Standard OR NSX for vShield Endpoint (free)	Advanced	Enterprise	NSX Data Center Standard	NSX Data Center Professional	NSX Data Center Advanced	NSX Data Center Enterprise Plus	NSX Data Center for Remote Office Branch Office	All license types
Method 1	✓	✓	✓	✓	✓	✓	✓	✓	✓
Method 2	X	✓ ¹	✓ ¹	X	X	✓ ¹	✓ ¹	✓ ¹	✓
Method 3	X	✓ ¹	✓ ¹	X	X	✓ ¹	✓ ¹	✓ ¹	✓

¹ Requires VMware's Network Introspection Service.

- Requires the following software combination: Deep Security Manager FR 2019-12-12 (build 12.5.494) or newer with Deep Security Agent Linux FR 2020-04-02 (build 12.5.0-814) or newer.

Method 1: Create a 'Computer Created' event-based task

Expand instructions

The instructions below are task-based. For more explanatory information on event-

based tasks, see ["Automated policy management in NSX environments"](#) on page 616.

1. In Deep Security Manager, click **Administration** at the top.
2. On the left, click **Event-Based Tasks**.
3. In the main pane, click **New**.
4. From the **Event** drop-down list, select **Computer Created (by System)**. Click **Next**.
5. Select **Activate Computer** and set it to 5 minutes.
6. Select **Assign Policy** and select a policy from the drop-down list, for example, **Windows Server 2016**. You can click the arrows to view child policies. Click **Next**.
7. Specify the conditions that restrict when the event-based task is triggered. Add this condition:

vCenter Name matches `<your_vCenter_name>`

8. Add more conditions to further restrict when the event-based task is triggered. For example, if you have a naming convention for your VMs that includes a 'Windows' prefix on all Windows VMs, you would set:

Computer Name matches `Windows*`

Click **Next**.

9. In the **Name** field, enter a name for the task that reflects the policy you assigned, for example, `Activate Windows Server 2016`.
10. Select **Task Enabled** and then click **Finish**.
11. Create additional event-based tasks, one per Deep Security policy you plan on assigning. The event-based task must have an event type of **Computer Created (by System)** and must be configured to activate the computer and assign a policy.

You have now set up your event-based tasks to activate and assign policies to newly-created VMs. As soon as a VM is created, all the **Computer Created (by System)** event-based tasks are reviewed. If the conditions in a task are met, the task is triggered, and the VM is activated and assigned the associated policy.

Method 2: Create an 'NSX Security Group Change' event-based task

Expand instructions

The instructions below are task-based. For more explanatory information on event-

based tasks, see "[Automated policy management in NSX environments](#)" on page 616.

To start, create or modify the **Activate** event-based task:

1. In Deep Security Manager, click **Administration** at the top.
2. On the left, click **Event-Based Tasks**.
3. In the main pane, look for the event-based task called **Activate <your_vCenter_name>**. It may or may not exist.
4. If the **Activate** event-based task exists, double-click it and review the table below make sure it is configured properly. If it doesn't exist, click **New** and run through the wizard, making sure to conform to the table below.
5. Create additional **Activate** event-based tasks if you added multiple vCenter servers to the manager.

Note: Settings in the table below may appear in a different order from shown.

To configure the 'Activate' event-based task, set...	To...
Name	A name for the task that reflects the action and vCenter assigned under Conditions , for example, <code>Activate your_vCenter_name</code> .
Event	NSX Security Group Change The NSX Security Group Change event is triggered when the manager receives a notification from the data plane (the Deep Security Virtual Appliance).
Task Enabled	Enabled.
Activate Computer	5 minutes.
Assign Policy	A policy, for example, Windows Desktop . You can click the arrows to view child policies.
Conditions	Mandatory condition to restrict when the event-based task is triggered:

To configure the 'Activate' event-based task, set...	To...
	<ul style="list-style-type: none"> • vCenter Name matches <code><your_vCenter_name></code> <p>Examples of optional conditions to further restrict triggering:</p> <ul style="list-style-type: none"> • Appliance Protection Available matches True. • Appliance Protection Activated matches False. • NSX Security Group Name matches <code>.+</code> (which means <i>any</i>)

Next, create or modify the **Deactivate** event-based task:

1. Still in Deep Security Manager, in the main pane, look for the event-based task called **Deactivate <your_vCenter_name>**. It may or may not exist.
2. If the **Deactivate** event-based task exists, double-click it and review the table below make sure it is configured properly. If it doesn't exist, click **New** and run through the wizard, making sure to conform to the table below.
3. Create additional **Deactivate** event-based tasks if you added multiple vCenter servers to the manager.

Note: Settings in the table below may appear in a different order from shown.

To configure the 'Deactivate' event-based task, set...	To...
Name	A name for the task that reflects the action and vCenter assigned under Conditions , for example, <code>Deactivate your_vCenter_name</code> .
Event	<p>NSX Security Group Change</p> <p>The NSX Security Group Change event is triggered when the manager receives a notification from the data plane (the Deep Security Virtual Appliance).</p>

To configure the 'Deactivate' event-based task, set...	To...
Task Enabled	Enabled.
Deactivate Computer	Enabled.
Conditions	<ul style="list-style-type: none"> • Appliance Protection Activated matches True. • NSX Security Group Name matches <code>^\$</code> (which means <i>none</i>) • vCenter Name matches <code><your_vCenter_name></code>

You have now set up your event-based tasks to activate your VMs. If the conditions in a task are met, the task is triggered, and the VM is activated (and assigned the associated policy).

Method 3: Synchronize your Deep Security policies to NSX-V

Expand instructions

The instructions below are task-based. For more explanatory information on synchronizing policies, see ["Synchronize Deep Security policies with NSX" on page 621](#).

To start, configure Deep Security Manager:

1. Log in to Deep Security Manager.
2. Make sure that all of the policies in Deep Security Manager have a unique name before they are synchronized with NSX. All the default ones have unique names.
3. At the top, click **Computers**.
4. On the left, right-click the vCenter where you want to enable synchronization and select **Properties**.
5. On the **NSX Configuration** tab, select **Synchronize Deep Security Policies with NSX Service Profiles**. Click **OK**.

Next, check that your policies are loading into vSphere:

1. In the vSphere Web Client Home page, click the **Networking & Security** button. **NSX Home** appears.
2. On the left, click **Service Definitions**.
3. In the main pane, under the **Services** tab, right-click **Trend Micro Deep Security** and select **Edit settings**.
4. In the main pane, select the **Manage** tab, and under that, select **Profile Configurations**.
5. Make sure the Deep Security policies are loading. They appear as individual NSX profile configurations of the same name. Each profile configuration has an ID that starts with a 'P', for example, P1, P2, P3, and so on. The 'P' indicates they are based on Deep Security policies.

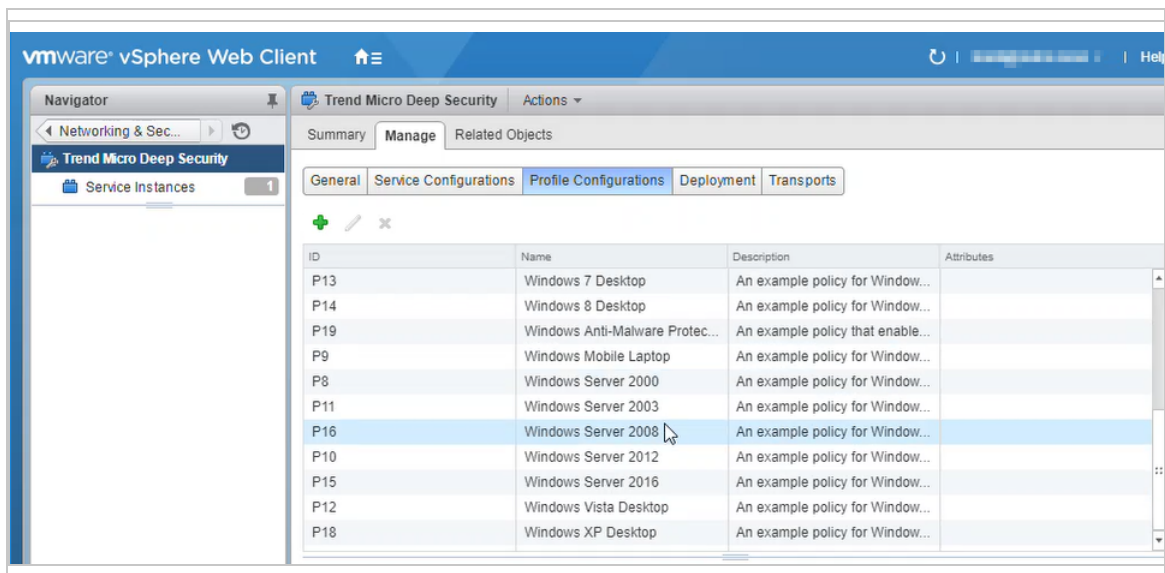

You have now added your Deep Security policies as profile configurations in NSX.

Finally, reconfigure your security groups and policies:

1. Go back to ["Step 6: Create an NSX security group and policy" on page 596](#) and run through the steps again, but this time making the adjustments described in the remaining steps.
2. Create multiple NSX security groups.
3. Create multiple NSX security policies. For each policy, set the Guest Introspection Services and Network Introspection Services (both inbound and outbound) **Service Profile** to one of the Deep Security policies that you just loaded.
4. Associate the NSX security policies with the NSX security groups.

Step 8: Trigger an activation and policy assignment

Your VMs are now ready to be activated and assigned a policy.

- If you chose Method 1, you'll need to manually synchronize the vCenter. Go to Deep Security Manager, right-click the vCenter on the left, and select **Synchronize Now**. Your existing VMs should now be protected.
- If you chose Method 2 or 3, all VMs should be activated and assigned policy automatically now. To check, see the next step.

Step 9: Check that VMs are activated and assigned a policy

To check:

1. In Deep Security Manager, click **Computers** at the top.
2. On the left, expand **Computers > <your_vCenter> > Virtual Machines**.
3. Check the **TASK(S)** and **STATUS** and columns. (Click **Columns** at the top to add them if they are not visible.) The **TASK(S)** column should indicate **Activating**, and your VMs should move from the **Unmanaged (Unknown)** status, to the **Unmanaged (No Agent)** status, to the **Managed (Online)** status. You may see the VMs move into the **VMware Tools Not Installed** status, but this is temporary.
4. Check the **POLICY** column to make sure the correct Deep Security policy was assigned.

You have now deployed Deep Security Virtual Appliance and protected your VMs with it.

Next steps (how to add new VMs)

Follow the instructions below to learn how to add new VMs to your system and protect them with Deep Security.

To add a new VM if you chose Method 1 (create a 'Computer Created' event-based task):

- Create a new VM in vCenter. This triggers the **Computer Created (by System)** event-based task, which activates and assigns policy to the new VM.

To add a new VM if you chose Method 2 (create an 'NSX Security Group Change' event-based task):

- Create or move the VM into one of the NSX security groups. This triggers the **NSX Security Group Change** event-based task, which activates and assigns policy to the new

VM.

To add a new VM if you chose Method 3 (synchronize Deep Security policies to NSX):

- Create or move the VM into one of the NSX security groups. This activates and assigns policy to the new VM.

Deploy the appliance in a vCloud environment

VMware vCloud integration enables the primary tenant in a multi-tenant installation to add a vCenter to their Deep Security Manager, configure a connector, and deploy and manage the Deep Security Virtual Appliance. The tenants can then import vCloud Organizations as cloud accounts and apply agentless Deep Security protection to them.

In this topic:

- ["Before you begin" below](#)
- ["Enable agentless protection of vCloud VMs" below](#)
- ["Create a multi-tenant environment" below](#)
- ["Add a vCenter and deploy the Deep Security Virtual Appliance" on the next page](#)
- ["Configure VMware vCloud resources for integration with Deep Security" on the next page](#)
- ["Activate virtual appliance protection on virtual machines" on page 614](#)

Before you begin

Complete the tasks in ["Before deploying the appliance" on page 551](#).

Enable agentless protection of vCloud VMs

1. In the Deep Security Manager console, go to **Administration > System Settings > Agents**.
2. Select the **Allow Appliance protection of vCloud VMs** check box.
3. Click **Save**.

Create a multi-tenant environment

There are two main task required to create a multi-tenancy environment: you must enable multi-tenancy and then create tenants. For step-by-step instructions on how to perform these tasks, as

well as requirements and recommendations for a multi-tenant environment, see ["Set up a multi-tenant environment"](#) on page 461.

Add a vCenter and deploy the Deep Security Virtual Appliance

The primary tenant must add a vCenter and deploy the Deep Security Virtual Appliance. For instructions, see ["Deploy the appliance \(NSX-T 3.x\)"](#) on page 554 or ["Deploy the appliance \(NSX-V\)"](#) on page 589

Configure VMware vCloud resources for integration with Deep Security

To configure VMware vCloud resources for integration with Deep Security:

- ["Create a minimum rights role for vCloud account tenant users"](#) below
- ["Assign unique UUIDs to new virtual machines"](#) on the next page
- ["Enable the OVF Environment Transport for VMware Tools on your guest VMs"](#) on the next page

Create a minimum rights role for vCloud account tenant users

The user accounts you create in vCloud Director that the Deep Security tenants will use to add their cloud accounts to their Deep Security Manager require only the **All Rights > General > Administrator View** right.

1. Log in to vCloud Director.
2. In the **System** tab, click on **Administration**.
3. In the navigation panel on the left, click on **Roles**.
4. Click the "plus" sign to create a new Role (for example, "DS_User").
5. Select the **Administrator View** right in the **All Rights > General** folder.
6. Click **OK**.

You can now assign this role to the user accounts you will give to Deep Security users to import their vCloud resources into the Deep Security Manager.

Note: When providing a Deep Security user with their credentials, you must include the IP address of the vCloud Organization and instruct them that when importing the vCloud resources into their Deep Security Manager, their username must include "@orgName". For example if the vCloud account's username is **kevin** and the vCloud Organization you've given the account access to is called **CloudOrgOne**, then the Deep Security user must enter

`kevin@CloudOrgOne` as their username when importing the vCloud resources. (For a vCloud administrator view, use `@system`.)

Note: You can configure Deep Security Manager to use a proxy server specifically for connecting to instances being protected in Cloud Accounts. The proxy setting can be found in **Administration > System Settings > Proxies > Proxy Server Use > Deep Security Manager (Cloud Accounts)**.

Assign unique UUIDs to new virtual machines

Deep Security requires that all protected virtual machines have unique UUIDs. Virtual machines created from a vApp template can be assigned duplicate UUIDs which can cause problems. To configure your vCloud database to assign unique UUIDs, set the `CloneBiosUuidOnVmCopy` property to zero (0) following [VMware Knowledge Base article 2002506](#).

Enable the OVF Environment Transport for VMware Tools on your guest VMs

Enabling the OVF Environment Transport for VMware Tools on your guest VMs will expose the `guestInfo.ovfEnv` environment variable making it easier for agents to uniquely identify their VMs to the Deep Security Manager. This will reduce the risk of VM misidentification.

1. In vCloud Director, open the VM's **Properties** screen, go the **Guest OS Customization** tab and select the **Enable guest customization** check box. Click **OK**.
2. In vCenter, select the same VM, open its **Properties** screen, go to the **Options** tab.
3. Click **vApp Options** and select the **Enabled** radio button. **OVF Settings** will now be exposed.
4. In **OVF Settings**, select the **VMware Tools** check box in the **OVF Environment Transport** area. Click **OK**.

If your VM is running, it must be restarted for the changes to take effect.

The data used by Deep Security are taken from the following properties:
`vmware.guestinfo.ovfenv.vcenterid` and `vmware.guestinfo.ovfenv.vcloud.computername`.

Activate virtual appliance protection on virtual machines

To activate virtual appliance protection, tenants must import vCloud Organization accounts and apply agentless Deep Security protection to them.

Note: vCloud Organization accounts must be added by tenants (not the primary tenant).

Import computers from a VMware vCloud Organization Account

1. In the Deep Security Manager, go to the **Computers** section, right-click **Computers** in the navigation panel and select **Add vCloud Account** to display the **Add vCloud Account** wizard.
2. In **Name** and **Description**, enter a display name and any additional notes.
3. In **Address**, enter the vCloud Director's hostname.
4. Enter your **User name** and **Password**.

Note: Your **User name** must be in the form `username@vcloudorganization`.

5. Click **Next**.
6. Deep Security Manager verifies the connection to the cloud resources and displays a summary of the import action. Click **Finish**.

The VMware vCloud resources now appear in the Deep Security Manager under their own branch under **Computers** in the navigation panel.

Import computers from a VMware vCloud Air Virtual data center

1. In the Deep Security Manager, go to the **Computers** section, right-click **Computers** in the navigation panel and select **Add vCloud Account** to display the **Add vCloud Account** wizard.
2. Enter a **Name** and **Description** of the VMware vCloud Air virtual data center you are adding. (These are only used for display purposes in the Deep Security Manager.)
3. Enter the **Address** of the VMware vCloud Air virtual data center.

To determine the address of the VMware vCloud Air virtual data center:

- a. Log in to your VMware vCloud Air portal.
 - b. On the **Dashboard** tab, click on the data center you want to import into Deep Security. This will display the **Virtual Data Center Details** information page.
 - c. In the Related Links section of the **Virtual Data Center Details** page, click on **vCloud Director API URL**. This will display the full URL of the vCloud Director API.
 - d. Use the hostname only (not the full URL) as the Address of the VMware vCloud Air virtual data center that you are importing into Deep Security.
4. Enter your **User name** and **Password**.

Note: Your **User name** must be in the form `username@virtualdatacenterid`.

5. Click **Next**.

6. Deep Security Manager will verify the connection to the virtual data center and display a summary of the import action. Click **Finish**.

The VMware vCloud Air data center now appears in the Deep Security Manager under its own branch under **Computers** in the navigation panel.

Activate virtual appliance protection on virtual machines

To activate virtual appliance protection, right-click on a virtual machine in the **Computers** list and click **Actions > Activate**.

Automated policy management in NSX environments

Note: If you have enabled synchronization of Deep Security policies to NSX, you will not need to use the **NSX Security Group Change** EBT. For information on policy synchronization, see ["Synchronize Deep Security policies with NSX" on page 621](#).

The security configuration of a VM in an NSX environment can be automatically modified based changes to the VM's NSX Security Group. The automation of security configuration is done using the **NSX Security Group Change** event-based task.

VMs are associated with NSX Security Groups, NSX Security Groups are associated with NSX Security Policies, and NSX Security Policies are associated with NSX Service Profiles.

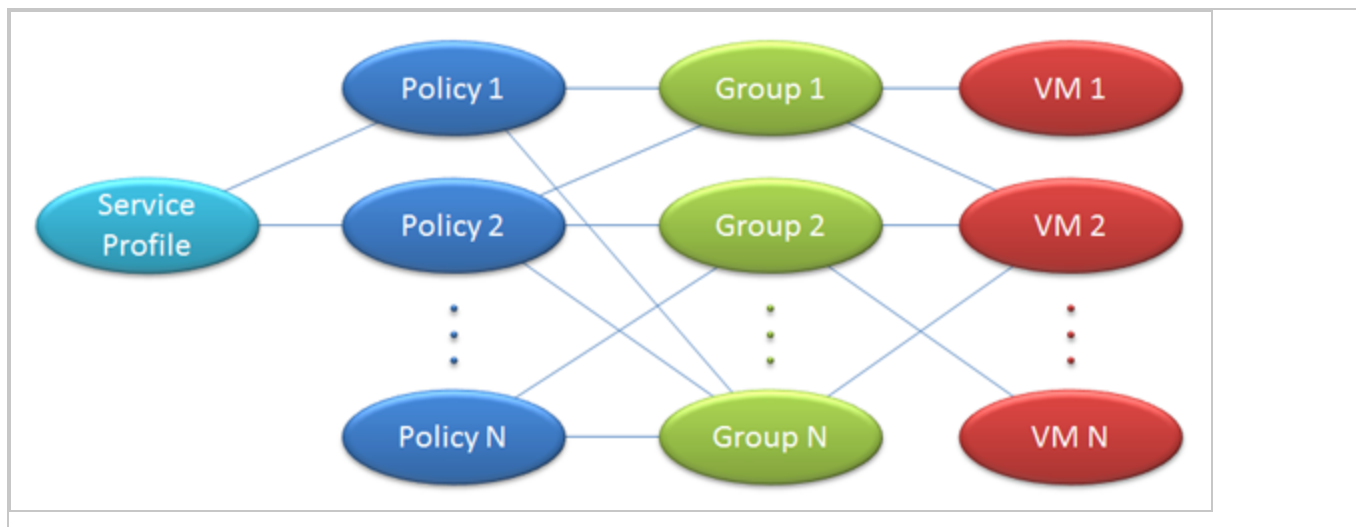

"NSX Security Group Change" event-based task

Deep Security has event-based tasks (EBTs) that can be configured to perform actions when specific events with specific conditions are detected. The **NSX Security Group Change** EBT exists to let you modify the protection settings of a VM if changes to the NSX Security Group that a VM belongs to are detected.

Note: The **NSX Security Group Change** EBT only detects changes to NSX Security Groups that are associated with the **Default (EBT)** NSX Service Profile. Similarly, a VM may be associated with many Groups and Policies, but Deep Security will only monitor and report changes that involve Groups and Policies associated with the **Default (EBT)** NSX Service Profile.

To modify that task, in Deep Security Manager, go to **Administration > Event-Based Tasks**.

The **NSX Security Group Change** EBT is triggered when any of the following events occur:

- A VM is added to an NSX Group that is (indirectly) associated with the **Default (EBT)** NSX Service Profile.
- A VM is removed from an NSX Group that is associated with the **Default (EBT)** NSX Service Profile.
- An NSX Policy associated with the **Default (EBT)** NSX Service Profile is applied to an NSX Group.
- An NSX Policy associated with the **Default (EBT)** NSX Service Profile is removed from an NSX Group.
- An NSX Policy is associated with the **Default (EBT)** NSX Service Profile.
- An NSX Policy is removed from the **Default (EBT)** NSX Service Profile.
- An NSX Group that is associated with an **Default (EBT)** NSX Service Profile changes name.

An event is triggered for each individual VM affected by a change.

Conditions under which to perform tasks

The following conditions are applicable to the **NSX Security Group Change** event-based task and can be tested against before performing an action:

- **Computer Name:** The hostname of the guest VM.
- **ESXi Name:** The hostname of the ESXi where the guest VM runs.
- **Folder Name:** The name of the guest VM's folder in the ESXi folder structure.
- **NSX Security Group Name:** The name of the NSX Security Group that was changed.
- **Platform:** The operating system of the guest VM.
- **vCenter name;** The name of the vCenter that the guest VM belongs to.
- **Appliance Protection Available:** A Deep Security Virtual Appliance is available to protect VMs on the ESXi on which the VM is hosted. The VM may or may not be in a "Activated" state.
- **Appliance Protection Activated:** A Deep Security Virtual Appliance is available to protect VMs on the ESXi on which the VM is hosted and the VM is "Activated".
- **Last Used IP Address:** The current or last known IP address of the VM computer.

For information on these conditions and event-based tasks in general, see ["Automatically perform tasks when a computer is added or changed \(event-based tasks\)" on page 1769](#).

The **NSX Security Group Name** condition is explicitly for changes to the **NSX Security Group Change** event-based task.

It accepts a java regular expression match to the NSX Security Group the VM belongs to whose properties have changed. Two special cases are considered:

- A match for membership in any group. In this case the recommended regular expression is `".+"`.
- A match for membership in no groups. In this case the recommended regular expression is `"^$"`.

Other regular expressions can include a specific group name or partial name (to match more than one group) as desired.

Note: The list of potential groups in this condition refers only to groups associated with policies associated with the **Default (EBT) NSX Service Profile**.

Available actions

The following actions can be performed on a VM when Deep Security detects a change to the NSX Security Group the VM belongs to:

- **Activate Computer:** Activate Deep Security protection by the Deep Security Virtual Appliance. Use this when a VM is moved into a Deep Security-protected NSX Security Group.
- **Deactivate Computer:** Deactivate Deep Security protection by the Deep Security Virtual Appliance. Use this when moving a VM out of a Deep Security-protected NSX Security Group. An Alert will be raised if this action is not performed when a VM is moved out a NSX Security Group protected by Deep Security because the VM can no longer be protected.
- **Assign Policy:** Assign a Deep Security Policy to a VM.
- **Assign Relay Group:** Assign a Relay Group to a VM.

Event-based tasks created when adding a vCenter to Deep Security Manager

Two event-based tasks can be created when adding an NSX vCenter to DSM. The last page of the **Add vCenter** wizard displays a checkbox. If selected, this option creates two event-based tasks. One to activate VMs when protection is added and the other to deactivate VMs when protection is removed.

The first event-based task is configured as follows:

- **Name:** Activate <vCenter Name>, where <vCenter Name> is the value seen in the Name field on the vCenter properties.
- **Event:** NSX Security Group Changed
- **Task Enabled:** True
- **Action:** Activate Computer after a delay of five minutes
- **Conditions:**
 - **vCenterName:** <vCenter Name> Must match because the EBT is vCenter-specific.
 - **Appliance Protection Available:** True. Must have an activated Deep Security Virtual Appliance on the same ESXi.
 - **Appliance Protection Activated:** False. This only applies to unactivated VMs.
 - **NSX Security Group:** ".+". Must be a member of one or more Deep Security Groups.

You can modify the actions associated with this event-based task, for example by applying a Deep Security protection policy or assigning a different relay group. The actions (and other properties) of any existing event-based tasks can be edited on the **Administration > Event-Based Tasks** page in the Deep Security Manager.

The second event-based task is configured as follows:

- **Name:** Deactivate <vCenter Name>, where <vCenter Name> is the value seen in the Name field on the vCenter properties.
- **Event:** NSX Security Group Changed
- **Task Enabled:** False
- **Action:** Deactivate Computer
- **Conditions:**
 - **vCenterName:** <vCenter Name>. Must match because the event-based task is vCenter-specific.
 - **Appliance Protection Activated:** True. This only applies to activated VMs.
 - **NSX Security Group:** "^\$". Must not be a member of any Deep Security Group.

Note: This event-based task is disabled by default. You can enable it and customize it as desired after the vCenter installation is complete.

Note: If multiple event-based tasks are triggered by the same condition, the tasks are executed in alphabetical order by task name.

Removal of a vCenter from Deep Security Manager

Whenever a vCenter is removed from Deep Security Manager disables all event-based tasks that meet the following criteria:

1. The **vCenter Name** condition matches the name of the vCenter being removed.

Note: This must be an exact match. Event-based tasks which match multiple vCenter names will not be disabled.

2. The event-based task **Event Type** is "NSX Security Group Changed". Event-based tasks with other event types are not disabled.

To remove a vCenter from Deep Security Manager, you'll first need to remove Deep Security artifacts from NSX. For instructions on removing Deep Security from NSX and vCenter from Deep Security Manager, see ["Uninstall Deep Security from your NSX environment" on page 1679](#).

Synchronize Deep Security policies with NSX

There are two ways to protect your VMs with Deep Security:

- Use event-based tasks to activate and deactivate VMs in Deep Security and apply or remove a default policy. For more information, see ["Event-based tasks created when adding a vCenter to Deep Security Manager" on page 619](#).
- Synchronize your Deep Security policies with NSX. This method is described below.

Each VM that you want to protect must belong to an NSX Security Group that has an NSX Security Policy assigned to it. When you set up an NSX Security Policy, one of the options that you select is the NSX Service Profile. With Deep Security 9.6 or earlier, there was only one NSX Service Profile for use with Deep Security. In Deep Security 9.6 SP1 or later, you can choose to synchronize all of your Deep Security policies with NSX. This creates a matching NSX Service Profile (which we call a "Mapped Service Profile" in Deep Security) for each of your Deep Security policies.

Enable policy synchronization:

Note: All of the policies in Deep Security Manager must have a unique name before they are synchronized with NSX.

1. In the Deep Security Manager, go to the **Computers** page and right-click the vCenter where you want to enable synchronization.
2. Click **Properties**.
3. On the **NSX Configuration** tab, select **Synchronize Deep Security Policies with NSX Service Profiles**. Click **OK**.

Next steps:

1. There are several steps required to protect your VMs with Deep Security Virtual Appliance, and they must be completed in a specific order. For a complete list of steps, see ["Deploy the appliance \(NSX-T 3.x\)" on page 554](#), ["Deploy the appliance \(NSX-V\)" on page 589](#), or ["Upgrade the appliance" on page 1637](#).

Change or remove the policy assigned to a VM

When a VM is protected by a Mapped Service Profile, the policy assignment cannot be changed from within Deep Security Manager. To change the profile used to protect a VM, you must change the NSX Security Policy or NSX Security Group from your vSphere Web Client (NSX-V) or NSX-T Data Center console (NSX-T).

If you unassign an NSX Security Policy from a group, any VMs in that group will be deactivated in Deep Security Manager.

Change the name of a policy

If you rename a policy in Deep Security Manager, the NSX Service Profile Name will also be changed.

Delete a policy

If you delete a policy in Deep Security Manager and the corresponding NSX Service Profile is not in use, it will be deleted. If the corresponding NSX Service Profile is in use, the NSX Service Profile will no longer be synchronized with Deep Security Manager and its name will be changed to indicate that it is no longer valid. If the NSX Service Profile becomes unused later, it will be deleted.

VMware vRealize

If you are configuring a blueprint with VMware vRealize, you can assign either a NSX Security Group or an NSX Security Policy to the blueprint. The Security Group or Security Policy can both use Mapped Service Profiles.

Configure DPDK mode

Note: Trend Micro supports this feature on NSX-T Data Center 3.x only.

[Intel Data Plane Development Kit \(DPDK\)](#) is a collection of open-source libraries that have been integrated into VMware to speed up packet processing for services that use VMware Network Intrpection. In the case of Deep Security, these services are Firewall, Intrusion Prevention, and Web Reputation.

To take advantage of the performance improvements offered by DPDK, you can configure the Deep Security Virtual Appliance in DPDK mode, as follows.

Before you begin:

1. Review "[Deep Security Virtual Appliance requirements](#)" on page 334. There are specific requirements for DPDK mode.
2. Make sure you have configured DPDK in VMware. See this [VMWare DPDK document](#) for an overview.
3. Understand that DPDK mode is configured during the appliance deployment. If you already have an appliance up and running, you'll need to redeploy it.

Configure DPDK mode:

1. Start the appliance deployment (see "Deploy the appliance (NSX-T 3.x)" on page 554) and stop when you get to "Configure and start the service deployment" on page 568 under "Install the appliance on NSX-T 3.x" on page 567.
2. Click **Configure Attributes**.

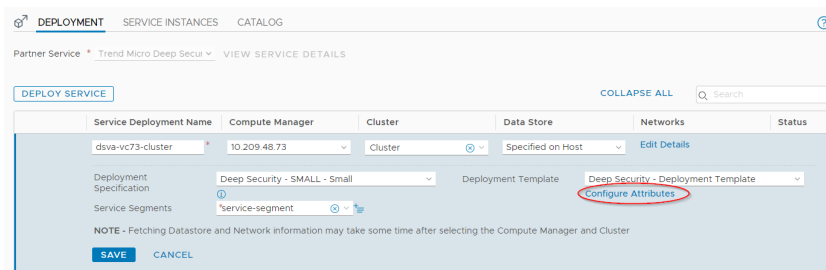

The **Configure Attributes** dialog box appears.

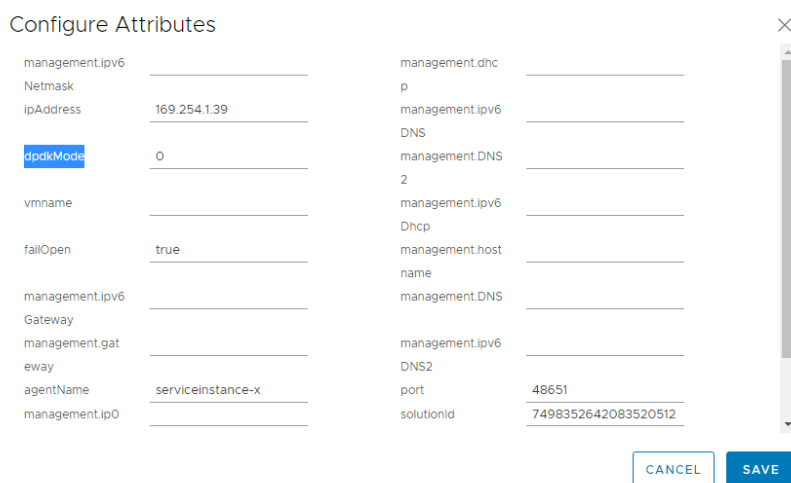

3. Find the **dpdkMode** field and modify the value according to the size of Deep Security Virtual Appliance. The possible values are:
 - **-1**: Deep Security Virtual Appliance determines the optimal CPU usage for DPDK mode. Specifically:
 - If the appliance OVF has ≥ 8 CPUs allocated, then in DPDK mode, it will have 4 CPUs allocated.
 - If the appliance OVF has 4 - 7 CPUs allocated, then in DPDK mode, it will have 2 CPUs allocated.
 - If the appliance OVF has 2 - 3 CPUs allocated, then in DPDK mode, it will have 1 CPU allocated.

- **0** (default): Disables DPDK mode. Deep Security Virtual Appliance uses the RAW Socket mode for Network Introspection.
4. Click **SAVE** to start the appliance deployment.
 5. Monitor and verify your deployment following the instructions in "[Monitor and verify the deployment](#)" on page 571

Configure NSX security tags

If you are using agentless protection, you can configure Deep Security Virtual Appliance to apply NSX security tags to protected VMs when the Anti-Malware and Intrusion Prevention (IPS) modules detect a threat. NSX security tags can be used with NSX Service Composer to automate certain tasks, such as quarantining infected VMs. For more information on NSX tagging and dynamic NSX security group assignment, see the documentation from VMware.

Note: VMware NSX security tags are *not* the same thing as Deep Security event tags. NSX tagging occurs in the VMware vSphere environment; Deep Security event tags are in the Deep Security database.

Topics on this page:

- "[Configure Anti-Malware to apply NSX security tags](#)" below
- "[Configure Intrusion Prevention to apply NSX security tags](#)" on the next page

Configure Anti-Malware to apply NSX security tags

To configure the Anti-Malware module to apply NSX security tags when malware is found:

1. Go to **Computer or Policy editor**¹ > **Anti-Malware** > **Advanced** > **NSX Security Tagging**.
2. Select **On** to enable the feature.
3. From the **NSX Security Tag** drop-down list, select the name of the NSX security tag that assigned in NSX when malware is found. Options are:
 - ANTI_VIRUS.VirusFound.threat=low
 - ANTI_VIRUS.VirusFound.threat=medium
 - ANTI_VIRUS.VirusFound.threat=high

¹You can change these settings for a policy or for a specific computer. To change the settings for a policy, go to the Policies page and double-click the policy that you want to edit (or select the policy and click Details). To change the settings for a computer, go to the Computers page and double-click the computer that you want to edit (or select the computer and click Details).

For example, if you choose **ANTI_VIRUS.VirusFound.threat=low**, then an NSX security tag called `ANTI_VIRUS.VirusFound.threat=low` is assigned to the VM if malware is found on the VM. The tag name is not related to the threat level of the malware, so the 'low' tag is applied even if the malware poses a high threat (and vice versa).

4. Optionally, select **Apply NSX Security Tag only if remediation action fails** if you only want to apply the NSX security tag if the remediation action attempted by the Anti-Malware module fails. (The remediation action is determined by the malware scan configuration that is in effect. To see which malware scan configuration is in effect, go to the **Computer or Policy editor**¹ > **Anti-Malware** > **General** tab and check the **Real-Time Scan**, **Manual Scan**, and **Scheduled Scan** areas.)
5. Optionally, select **Remove previously applied NSX Security Tags if subsequent Malware Scans complete without any malware detection events**. Choose this option if you want to have the security tag removed if a subsequent malware scan does not detect any malware. You should only use this setting if all malware scans are of the same kind.
6. Click **Save**.

Configure Intrusion Prevention to apply NSX security tags

To configure the Intrusion Prevention module to apply NSX security tags, go to **Computer or Policy editor**² > **Intrusion Prevention** > **Advanced** > **NSX Security Tagging**.

Intrusion Prevention events have a severity level that is determined by the severity level of the Intrusion Prevention rule that triggered the event. To configure the severity level of an Intrusion Prevention rule, go to **Computer or Policy editor**³ > **Intrusion Prevention** > **General** > **Assigned Intrusion Prevention Rules** and double-click a rule. Change the **Severity** field as required.

Intrusion Prevention rule severity levels map to NSX tags as follows:

¹You can change these settings for a policy or for a specific computer. To change the settings for a policy, go to the Policies page and double-click the policy that you want to edit (or select the policy and click Details). To change the settings for a computer, go to the Computers page and double-click the computer that you want to edit (or select the computer and click Details).

²You can change these settings for a policy or for a specific computer. To change the settings for a policy, go to the Policies page and double-click the policy that you want to edit (or select the policy and click Details). To change the settings for a computer, go to the Computers page and double-click the computer that you want to edit (or select the computer and click Details).

³You can change these settings for a policy or for a specific computer. To change the settings for a policy, go to the Policies page and double-click the policy that you want to edit (or select the policy and click Details). To change the settings for a computer, go to the Computers page and double-click the computer that you want to edit (or select the computer and click Details).

IPS Rule Severity	NSX Security Tag
Critical	IDS_IPS.threat=high
High	IDS_IPS.threat=high
Medium	IDS_IPS.threat=medium
Low	IDS_IPS.threat=low

You can configure the sensitivity of the tagging mechanism by specifying the minimum Intrusion Prevention severity level that can cause an NSX security tag to be applied to a VM.

The options for the **Minimum rule severity to trigger application of an NSX Security Tag** setting are:

- **Default (No Tagging):** No NSX tag is applied.
- **Critical:** An NSX tag is applied to the VM if an Intrusion Prevention rule with a severity level of **Critical** is triggered.
- **High:** An NSX tag is applied to the VM if an Intrusion Prevention rule with a severity level of **High** or **Critical** is triggered.
- **Medium:** An NSX tag is applied to the VM if an Intrusion Prevention rule with a severity level of **Medium**, **High**, or **Critical** is triggered.
- **Low:** An NSX tag is applied to the VM if an Intrusion Prevention rule with a severity level of **Low**, **Medium**, **High**, or **Critical** is triggered.

Separate settings exist for rules in prevent mode vs. detect-only mode. For information about behavior modes, see ["Use behavior modes to test rules" on page 879](#).

Configure the appliance OVF location

By default, the Deep Security Virtual Appliance OVF file is located at `https://<deep_security_manager_host>:4119/dsva/dsva.ovf`. If you want, you can place the OVF at a different location, such as on a separate web server, and then point your manager to it. You might want to do this:

- to improve reliability, and improve the download speed of the appliance OVF by NSX.
- to fix deployment errors in NSX caused by connectivity issues. The error might look like this: *Installation of deployment unit failed, please check if ovf/vib urls are accessible, in correct format and all the properties in ovf environment have been configured in service attributes. Please check logs for details.*

To configure the appliance OVF location:

First, obtain the appliance ZIP package (it contains the OVF file):

1. In Deep Security Manager, click **Administration** at the top.
2. On the left, expand **Updates > Software > Local** (if you've already imported the virtual appliance), or **Updates > Software > Download Center** (if you haven't).
3. Find the virtual appliance ZIP file. It is named `Appliance-ESX-<appliance_version>.x86_64.zip`.
4. Click **Export > Export Package**. The ZIP downloads to the local computer.

Next, place the appliance files on a web server:

1. Extract the ZIP file.
2. In the root of the ZIP file, find the `dsva.ovf` and `system.vmdk` files.

Note: If the ZIP file version is 12 Update 3 (12.0.682) or later, find instead the `*.ovf`, `*.vmdk`, `*.mf`, and `*.cert` files. There will be several files geared towards different sizes of deployment.

3. Place these files on a web server that is accessible to your ESXi and manager server.
4. On the web server, add the MIME type of each of the file types you just copied. The MIME types are described in the following table. Consult your web server documentation for detailed instructions on adding MIME types to the web server.

File extension	MIME type
ovf	application/vmware
vmdk	application/octet-stream
mf	text/cache-manifest
cert	application/x-x509-user-cert

Finally, configure the manager to point to the new OVF location:

1. In Deep Security Manager, click **Computers** at the top.
2. On the left, expand **Computers**, right-click your vCenter, and select **Properties**.
3. Click the **NSX Configuration** tab.
4. Select **Host the Deep Security Virtual Appliance software package on a local Web Server instead of Deep Security Manager database**.

5. Under **URL to Virtual Appliance OVF**, enter the URL location of the OVF file. Examples:

- `https://my.webserver.com/dsva/dsva.ovf`

Or

- `https://my.webserver.com/dsva/dsva-12.0.0-682_small.ovf`

For help on which OVF file to choose, see ["Deep Security Virtual Appliance sizing" on page 407](#).

6. Click **OK**.

The appliance OVF is now accessible to the manager and your ESXi server. You should now be able to deploy the appliance from its new location. For instructions on deploying or upgrading the appliance, see ["Deploy the appliance \(NSX-T 3.x\)" on page 554](#), ["Deploy the appliance \(NSX-V\)" on page 589](#), or ["Upgrade the appliance" on page 1637](#).

Deep Security Virtual Appliance memory allocation

In an NSX Data Center for vSphere (NSX-V) environment, Deep Security Virtual Appliance uses 4 GB of RAM by default. If you expect to need more RAM, you will need to modify the appliance's configuration. There are two options:

- Modify the configuration of the appliance prior to being imported to the vCenter, thereby setting the default configuration for all subsequent appliance service deployments in that vCenter.
- Modify the memory allocation of the appliance on a case-by-case basis after it has been imported to the vCenter and deployed as a service on a ESXi.

For information about the amount of RAM to allocate for appliances, see ["Deep Security Virtual Appliance sizing" on page 407](#).

Configure the appliance's memory allocation prior to deployment to the vCenter

Note: This topic is not applicable to NSX-T 3.0 Data Center environments.

To change the appliance's default memory allocation, you must edit the allocation settings in the appliance's OVF file before it gets imported to the vCenter.

1. Import the appliance ZIP into Deep Security Manager and wait for the appliance package folder to fully download to `<DSM_Install>\temp\Appliance-ESX-<appliance_version>`.

Warning: You must import the appliance ZIP *before* changing the memory allocation settings in the OVF. If you reverse these tasks, the modified OVF file will cause a digital signature check failure, which in turn will lead to an import failure.

2. In a text editor, open `dsva.ovf` in `<DSM_install>\temp\Appliance-ESX-<appliance_version>`.
3. Edit the default memory allocation (4096 MB) to be appropriate for your environment. See, "[Deep Security Virtual Appliance sizing](#)" on page 407 for more information.

```
<Item>
<rasd:AllocationUnits>byte * 2^20</rasd:AllocationUnits>
<rasd:Description>Memory Size</rasd:Description>
<rasd:ElementName
xmlns:rasd="http://schemas.dmtf.org/wbem/wscim/1/cim-schema/2/CIM_
ResourceAllocationSettingData">4096 MB of memory</rasd:ElementName>
<rasd:InstanceID xmlns:rasd="http://schemas.dmtf.org/wbem/wscim/1/cim-
schema/2/CIM_ResourceAllocationSettingData">2</rasd:InstanceID>
<rasd:Reservation>4096</rasd:Reservation>
<rasd:ResourceType>4</rasd:ResourceType>
<rasd:VirtualQuantity>4096</rasd:VirtualQuantity>
</Item>
```

4. Save the OVF file.
5. If you imported multiple appliance packages to Deep Security Manager, modify the `dsva.ovf` in each `\Appliance-ESX-<appliance_version>` folder.

You can now deploy the virtual appliance OVF file into vCenter. See "[Deploy the appliance \(NSX-T 3.x\)](#)" on page 554, or "[Deploy the appliance \(NSX-V\)](#)" on page 589.

Configure the memory allocation of an already-deployed appliance

Warning: Changing the appliance's memory allocation settings requires powering off the appliance's virtual machine. Virtual machines normally protected by the appliance will be unprotected until it is powered back on. To mitigate this, temporarily configure agent-based protection where possible.

1. In your VMware vSphere Web Client, right-click on the appliance and select **Power > Shut Down Guest**.
2. Right-click on the appliance again and select **Edit Settings**. The Virtual Machine **Properties** screen displays.
3. On the **Hardware** tab, select **Memory** and change the memory allocation to the desired value.
4. Click **OK**.
5. Right-click the appliance again and select **Power > Power On**.

Start or stop the appliance

To start or stop the Deep Security Virtual Appliance, you must start or stop its embedded Deep Security Agent. This can only be done locally on the host computer.

To start or stop the agent on Linux:

Using SysV init scripts:

- **Start:** `/etc/init.d/ds_agent start`
- **Stop:** `/etc/init.d/ds_agent stop`

Using systemd commands:

- **Start:** `systemctl start ds_agent`
- **Stop:** `systemctl stop ds_agent`

Deploy Deep Security notifier

The Deep Security notifier is a utility for physical or virtual Windows machines which provides local notification when malware is detected or malicious URLs are blocked. The Deep Security notifier is automatically installed as part of the Deep Security Agent on Windows machines. The stand-alone installation described here is intended for use on agentless Windows VMs being protected by the Deep Security Virtual Appliance. For more information, see ["Deep Security notifier" on page 1478](#).

Copy the Installation Package

Copy the installation file to the computer.

Install the Deep Security notifier for Windows

Note: Remember that you must have administrator privileges to install and run the Deep Security notifier on Windows machines.

1. Double-click the installation file to run the installer package. Click **Next** to begin the installation.
2. Read the license agreement and click **Next**.
3. Click **Install** to proceed with the installation.
4. Click **Finish** to complete the installation.

The Deep Security notifier is now installed and running on this computer, and the notifier icon appears in the Windows taskbar. When malware is detected or a URL has been blocked, the notifier will display pop-up notifications. You can manually disable them by double-clicking the tray icon to open the notifier status and configuration window.

Note: On VMs protected by a virtual appliance, the anti-malware module must be licensed and enabled on the VM for the Deep Security notifier to display information.

User Guide

Add computers

About adding computers

The **Computers** page in Deep Security Manager enables you to manage and monitor the computers you are protecting with Deep Security.

This page regularly refreshes itself to display the most current information. (You can modify the refresh rate on a per-user basis. Go to **Administration > User Management > Users** and then double-click on a user account to open its **Properties** window. On the **Settings** tab, in the **Refresh Rate** section, modify the page refresh rate.)

Add computers to the manager

Note: After being installed on a computer, an agent must be activated by the Deep Security Manager. During activation, the Deep Security Manager sends a fingerprint to the agent, after which the agent accepts instructions only from a manager with that unique fingerprint.

Note: If you install an agent on a virtual machine that was previously being protected agentlessly by a Deep Security Virtual Appliance, the virtual machine has to be activated again from the manager to register the presence of the agent on the computer.

You can add computers through the **Computers** page.

Group computers

Creating computer groups is useful from an organizational point of view and it speeds up the process of applying and managing policies. Groups are displayed in the tree structure on the left side of the Computers page. To create a new group, select the computer group under which you want to create the new computer group and then click **Add > Create Group(s)**.

To move a computer to a group, select the computer and click **Actions > Move to Group**. Keep in mind that policies are applied at the computer level, not the computer group level. Moving a computer from one computer group to another has no effect on the policy assigned to that computer.

To remove a group, right-click it and click **Remove Group**. You can only remove a computer group if it contains no computers and has no sub-groups.

You can also "[Group computers dynamically with smart folders](#)" on page 1542.

Export your computers list

You can click **Export** on the Computers page to export your computers list to an XML or CSV file. Exporting is useful when you want to back up your computer information, integrate it with other reporting systems, or to migrate computers to another Deep Security Manager. (If you export, you do not have to re-discover and scan computers from the new manager.)

Note: The exported computers file does **not** include any assigned policies, firewall rules, firewall stateful configurations or intrusion prevention rules. To export this configuration information use the Policy export option in the **Policies** page.

Delete a computer

If you delete a computer (by selecting it and clicking **Delete**), all information pertaining to that computer is deleted along with it. If you re-discover the computer, you will have to re-assign a policy and whatever rules were assigned previously.

Add local network computers

Agent-initiated activation

If the Deep Security Manager cannot initiate communication with computers that you want to protect (for example, if computers are on a different local network or are protected by a firewall), then computers must initiate connections to the manager instead. This includes the connection for agent activation. To use agent-initiated activation, you must install the Deep Security Agent on the computer and then run a set of command-line instructions which tell the agent to communicate with the Deep Security Manager. During the communication, the Deep Security Manager activates the agent and can be further instructed to perform a number of other actions such as assigning a security policy, making the computer a member of a computer group, and so on.

If you are going to add a large number of computers to the Deep Security Manager at one time, you can use the command-line instructions to create scripts to automate the process. For more information on agent-initiated activation, scripting, and command line options, see "[Command-line basics](#)" on page 1731.

Manually add a computer

You can manually add an individual computer by specifying its IP address or hostname.

1. Go to the **Computers** page and click **Add > Add Computer** in the toolbar to display the **New Computer** wizard.
2. Enter the new computer's IP address or hostname.
3. Select a policy to assign to it from the list.
4. Select a relay group from which the new computer will download security updates.
5. Click **Next** to begin the search for the computer.

If the computer is detected and an agent is installed and running on that computer, the computer will be added to your computers list and the agent will be activated.

Note: "Activating" an agent means that the manager communicates with the agent sending it a unique "fingerprint". The agent will then use this fingerprint to uniquely identify the Deep Security Manager and will not accept instructions from any other managers that might try to contact it.

If a policy has been assigned to the computer, the policy will be deployed to the agent and the computer will be protected with all the rules and configurations that make up the policy.

By default, the security updates delivered by relay groups include new malware patterns. If you have enabled the **Support 9.0 (and earlier) agents** option (on the **Administration > System Settings > Updates** page), updates to the engines will also be included.

If the computer is detected but no Deep Security Agent is present, you will be told that the computer can still be added to your computers list but that you still have to install an agent on the computer. Once you install an agent on the computer, you will have to find the computer in your computers list, right-click it, and choose **Activate/Reactivate** from the context menu.

If the computer is not detected (not visible to the manager), you will be told that you can still add the computer but that when it becomes visible to the manager you will have to activate it as above.

Discover computers

A discovery operation scans the network for visible computers. To initiate a discovery operation, go to the **Computers** page, click **Add > Discover**. The Discover Computers dialog will appear.

You are provided several options to restrict the scope of the scan. You can choose to perform a port scan of each discovered computer.

Note: If you are discovering or scanning a large number of computers, a port scan can take time and reduce performance until it is complete.

When discovering computers, you can specify a computer group to which they should be added. Depending on how you have chosen to organize your computer groups, it may be convenient to create a computer group called "Newly Discovered Computers", or "Newly Discovered Computers on Network Segment X" if you will be scanning multiple network segments. You can then move your discovered computers to other computer groups based on their properties and activate them.

During discovery, the manager searches the network for any visible computers that are not already listed. When a computer is found, the manager attempts to detect whether an agent is present. When discovery is complete, the manager displays all the computers it has detected and displays their status in the **Status** column.

Note: The Discovery operation only checks the status of newly-discovered computers. To update the status of already-listed computers, right-click the selected computer(s) and click **Actions > Check Status**.

After discovery operations, a computer can be in one of the following states:

- **Discovered (No Agent):** The computer has been detected but no agent is present. The computer may also be in this state if an agent is installed but has been previously activated and is configured for agent initiated communications. In this case, you will have to deactivate and then reactivate the agent. ("No Agent" will also be reported if the agent is installed but not running.)
- **Discovered (Activation Required):** The agent is installed and listening, and has been activated, but is not yet being managed by the manager. This state indicates that this manager was at one point managing the agent, but the agent's public certificate is no longer in the manager's database. This may be the case if the if the computer was removed from the manager and then discovered again. To begin managing the agent on this computer, right-click the computer and select **Activate/Reactivate**. Once reactivated, the **Status** will change to "Online".
- **Discovered (Deactivation Required):** The agent is installed and listening, but it has already been activated by another manager. In this case, the agent must be deactivated (reset) prior to activation by this manager. Deactivating an agent can be done using the manager that originally activated it or it can be reset through the command line. To deactivate the agent from the manager, right-click the computer and choose **Actions > Deactivate**. To deactivate the agent from the command line, see ["Reset the agent" on page 1746](#).
- **Discovered (Activated):** The agent is installed and activated by the current manager. In this case, the status will change to "Online" on the next heartbeat. To begin managing the agent, right-click the computer and select **Activate/Reactivate**. Once reactivated, the **Status** will change to "Online".

Note: The discovery operation does not discover computers running as virtual machines in a vCenter, computers in a Microsoft Active Directory or in other LDAP directories.

Add Active Directory computers

Deep Security can use an LDAP server such as Microsoft Active Directory for computer discovery and to create user accounts and their contacts. Deep Security Manager queries the server, and then displays computer groups according to the structure in the directory.

If you are using Deep Security in FIPS mode, you must import the Active Directory's SSL certificate into Deep Security Manager before connecting the manager with the directory. See ["Manage trusted certificates" on page 1603](#).

1. In Deep Security Manager, click **Computers**.
2. In the main pane, click **Add > Add Active Directory**.
3. Type the host name or IP address, name, description, and port number of your Active Directory server. Also enter your access method and credentials. Follow these guidelines:
 - The **Server Address** must be the same as the Common Name (CN) in the Active Directory's SSL certificate if the access method is LDAPS.
 - The **Name** doesn't have to match the directory's name in Active Directory.
 - The **Server Port** is [Active Directory's LDAP or LDAPS port](#). The defaults are 389 (LDAP and StartTLS) and 636 (LDAPS).
 - The **Username** must include your domain name. For example, `EXAMPLE/Administrator`.
 - If you are using Deep Security in FIPS mode, click **Test Connection** in the Trusted Certificate section to check whether the Active Directory's SSL certificate has been imported successfully into Deep Security Manager.

Click **Next** to continue.

4. Specify your directory's schema. If you have not customized the schema, you can use the default values for a Microsoft Active Directory server.

The **Details** window of each computer in Deep Security Manager has a **Description** field. To use an attribute of the "Computer" object class from your Active Directory to populate the "Description" field, type the attribute name in the **Computer Description Attribute** text box.

Select **Create a Scheduled Task to Synchronize this Directory** if you want to automatically keep this structure in the Deep Security Manager synchronized with your Active Directory

server. A **Scheduled Task** wizard will appear when you are finished adding the directory. You can set this up later using the **Scheduled Tasks** wizard: **Administration > Scheduled Tasks**.

5. Click **Next** to continue.
6. When the Manager has imported your directory, it will display a list of computers that it added. Click **Finish**.

The directory structure will appear on the **Computers** page.

Additional Active Directory options

Right-clicking an Active Directory structure gives you options that are not available for non-directory computer groups:

- **Remove Directory**
- **Synchronize Now**

Remove Directory

When you remove a directory from the Deep Security Manager, you have these options:

- **Remove directory and all subordinate computers/groups from DSM:** Remove all traces of the directory.
- **Remove directory but retain computer data and computer group hierarchy:** Turn the imported directory structure into identically organized regular computer groups, no longer linked with the Active Directory server.
- **Remove directory, retain computer data, but flatten hierarchy:** Remove links to the Active Directory server, discards directory structure, and places all the computers into the same computer group.

Synchronize Now

You can manually trigger Deep Security Manager to synchronize with the Active Directory server to refresh information on computer groups.

Tip: You can automate this procedure by creating a scheduled task.

Server certificate usage

If it is not already enabled, enable SSL on your Active Directory server.

Computer discovery can use either SSL or TLS or unencrypted clear text, but importing user accounts (including passwords and contacts) requires authentication and SSL or TLS.

SSL or TLS connections require a server certificate on your Active Directory server. During the SSL or TLS handshake, the server will present this certificate to clients to prove its identity. This certificate can be either self-signed or signed by a certificate authority (CA). If you don't know if your server has a certificate, on the Active Directory server, open the Internet Information Services (IIS) Manager, and then select **Server Certificates**. If the server doesn't have a signed server certificate, you must install it.

Import users and contacts

Deep Security can import user account information from Active Directory and create corresponding Deep Security users or contacts. This offers the following advantages:

- Users can use their network passwords as defined in Active Directory.
- Administrators can centrally delete accounts from within Active Directory.
- Maintenance of contact information is simplified (e.g., email, phone numbers, etc.) by leveraging information already in Active Directory.

Both users and contacts can be imported from Active Directory. Users have configuration rights on the Deep Security Manager. Contacts can only receive Deep Security Manager notifications. The synchronization wizard allows you to choose which Active Directory objects to import as users and which to import as contacts.

To successfully import an Active Directory user account into Deep Security as a Deep Security user or contact, the Active Directory user account must have a **userPrincipalName** attribute value. The **userPrincipalName** attribute corresponds to an Active Directory account holder's "User logon name".

1. Click **Administration > User Management** and then click either **Users** or **Contacts**.
2. Click **Synchronize with Directory**.

If this is the first time user or contact information is imported, the server information page is displayed. Otherwise, the Synchronize with Directory wizard is displayed.

3. Select the appropriate access options, provide logon credentials, and click **Next**.

4. Select the groups you want to synchronize by selecting them from the left column and

clicking >> to add them to the right column and then click **Next**.

Tip: You can select multiple groups by holding down shift or control while clicking on them.

5. Select whether to assign the same Deep Security role to all Directory group members or to assign Deep Security roles based on Directory Group membership and then select a default role from the list and click **Next**.
6. If you assigned Deep Security roles based on Directory Group membership, specify the synchronization options for each group and click **Next**.

After synchronization, the wizard generates a report showing the number of objects imported.

Before you finish the synchronization, you can choose to create a scheduled task to regularly synchronize users and contacts.

7. Click **Finish**.

Once imported, you will be able to tell the difference between organic (non-imported) Deep Security accounts and imported accounts because you will not be able to change any general information for these accounts.

Keep Active Directory objects synchronized

Once imported, Active Directory objects must be continually synchronized with their Active Directory servers to reflect the latest updates for these objects. This ensures, for example, that computers that have been deleted in Active Directory are also deleted in Deep Security Manager. To keep the Active Directory objects that have been imported to the Deep Security Manager synchronized with Active Directory, it is essential to set up a scheduled task that synchronizes directory data. The wizard to import computers includes the option to create these scheduled tasks.

Alternatively, you can create this task using the Scheduled Task wizard. On-demand synchronization can be performed using the **Synchronize Now** option for computers and **Synchronize with Directory** button for users and contacts.

You do not need to create a scheduled task to keep users and contacts synchronized. At login, Deep Security Manager checks whether the user exists in Active Directory. If the username and password are valid, and the user belongs to a group that has synchronization enabled, the user will be added to Deep Security Manager and allowed to log in.

If you disable an account in Active Directory but do not delete it, the user remains visible and active in Deep Security Manager.

Disable Active Directory synchronization

You can stop Deep Security Manager from synchronizing with Active Directory for both computer groups and user accounts.

Remove computer groups from Active Directory synchronization

1. Go to **Computers**.
2. Right-click the directory, and select **Remove Directory**.
3. Select what to do with the list of computers from this directory when Deep Security Manager stops synchronizing with it:
 - **Remove directory and all subordinate computers/groups from Deep Security Manager:** Remove this directory's structure.
 - **Remove directory but retain computer data and group hierarchy:** Keep the existing structure, including its user and role access to folders and computers.
 - **Remove directory, retain computer data, but flatten hierarchy:** Convert the directory's structure to a flat list of computers inside a group that is named after the directory. The new computer group has the same user and role access as the old structure.
4. Confirm the action.

Delete Active Directory users and contacts

Unlike when you remove directory queries for computer groups, if you delete the query for users and contacts, all those accounts will be deleted from Deep Security Manager. As a result, you cannot delete while logged into Deep Security Manager with a user account that was imported from the directory server. Doing so will result in an error.

1. On either **Users** or **Contacts**, click **Synchronize with Directory**.
2. Select **Discontinue Synchronization** and then click **OK**.
3. Click **Finish**.

Add AWS instances

About adding AWS accounts

Topics:

- ["Overview of methods for adding AWS accounts" below](#)
- ["What happens when you add an AWS account?" below](#)
- ["What are the benefits of adding an AWS account?" below](#)
- ["What AWS regions are supported?" on the next page](#)

Overview of methods for adding AWS accounts

There are a few ways to add AWS accounts to Deep Security Manager:

- ["Add an AWS account using a manager instance role" on the next page](#). Use this method if Deep Security Manager is **inside** AWS.
- ["Add an AWS account using an access key" on page 646](#). Use this method if Deep Security Manager is **outside** AWS.
- ["Add an AWS account using a cross-account role" on page 649](#). Use this method if you want to add multiple AWS accounts.

What happens when you add an AWS account?

When you add an AWS account to Deep Security, all the Amazon EC2 and Amazon WorkSpace instances under that account are imported into Deep Security Manager and become visible in one of these locations:

- EC2 instances appear on the left under **Computers** > *your_AWS_account* > *your_region* > *your_VPC* > *your_subnet*
- Amazon WorkSpaces appear on the left under **Computers** > *your_AWS_account* > *your_region* > **WorkSpaces**

Once imported, the EC2 and WorkSpace instances can be managed like any other computer. These instances are tree structures and are treated as computer groups.

Note: If you previously added Amazon EC2 instances or Amazon WorkSpaces as individual computers, and they are part of your AWS account, after importing the account, the instances are moved into the [tree structure](#) described above.

What are the benefits of adding an AWS account?

The benefits of adding an AWS account (through Deep Security Manager > **Computers** > **Add AWS Account**) instead of adding individual EC2 instances and WorkSpaces (through Deep Security Manager > **Computers** > **Add Computer**), are:

- Changes in your EC2 and WorkSpaces inventory are automatically reflected in Deep Security Manager. For example, if you delete a number of EC2 or WorkSpace instances in AWS, those instances disappear automatically from the manager. By contrast, if you use **Computers > Add Computer**, EC2 and WorkSpace instances that are deleted from AWS remain visible in the manager until they are manually deleted.
- Your EC2 and WorkSpace instances are organized into AWS region > VPC > subnet in the manager, which lets you easily see which instances are protected and which are not. Without the AWS account, all your EC2 and WorkSpace instances appear at the same root level under **Computers**.
- You get AWS metadata, which can be used in [event-based tasks \(EBTs\)](#) to simplify policy assignment. You can also use metadata with [smart folders](#) to organize your AWS instances.

What AWS regions are supported?

Deep Security Manager's **Computers > Add > Add AWS Account** option only supports AWS regions that use the global AWS Identity Access Management (IAM) service at `iam.amazonaws.com`. To determine whether your region uses the global service, see [this table](#).

At the time of writing, the following regions do **not** use the global IAM service (`iam.amazonaws.com`):

- China (Beijing)
- China (Ningxia)
- AWS GovCloud (US-East)
- AWS GovCloud (US)

For the regions listed above, and any others that might not use the global IAM service, you can still load your EC2 and WorkSpace instances into the manager [using the Deep Security REST API](#). Trend Micro has provided [this sample script](#) for your use.

Add an AWS account using a manager instance role

Follow the instructions below to add an AWS account to Deep Security Manager using a manager instance role. Use this method if Deep Security Manager is running inside of AWS.

Note: The term 'AWS Primary Account' will be used throughout this topic to describe the AWS account under which your Deep Security Manager is located.

First, log in to the AWS Primary Account

1. Go to Amazon Web Services at <https://aws.amazon.com/>.
 2. Sign in using your AWS Primary Account.
-

Next, configure an IAM policy

1. In the Amazon Web Services Console, go to the **IAM** service.
2. In the left navigation pane, click **Policies**.

Note: If this is your first time on this page, you'll need to click **Get Started**.

3. Click **Create policy**.
4. Select the **JSON** tab.
5. Copy the following JSON code into the text box:

```
{
  "Version": "2012-10-17",
  "Statement": [
    {
      "Sid": "cloudconnector",
      "Action": [
        "ec2:DescribeImages",
        "ec2:DescribeInstances",
        "ec2:DescribeRegions",
        "ec2:DescribeSubnets",
        "ec2:DescribeTags",
        "ec2:DescribeVpcs",
        "ec2:DescribeAvailabilityZones",
        "ec2:DescribeSecurityGroups",
        "workspaces:DescribeWorkspaces",
        "workspaces:DescribeWorkspaceDirectories",
        "workspaces:DescribeWorkspaceBundles",
        "workspaces:DescribeTags",
        "iam:ListAccountAliases",
        "iam:GetRole",
        "iam:GetRolePolicy",
        "sts:AssumeRole"
      ]
    }
  ]
}
```

```
    ],  
    "Effect": "Allow",  
    "Resource": "*"    
  }  
]  
}
```

Note: The "sts:AssumeRole" permission is required only if you plan on [adding more AWS accounts to the manager \(using cross account roles\)](#).

Note: The "iam:GetRole" and "iam:GetRolePolicy" permissions are optional, but recommended because they allow Deep Security to determine whether you have the correct policy when an update to the manager occurs that requires additional AWS permissions.

6. Click **Review policy**.
7. Give the policy a name and description. Example name: `Deep_Security_Policy`.
8. Click **Create policy**. Your policy is now ready to use.

Next, create a manager instance role

1. Go to the **IAM** service.
2. Click **Roles**.
3. Click **Create role**.
4. Make sure the **AWS service** box is selected.
5. Click **EC2** from the list of services. More options are revealed.
6. Click **EC2 Allows EC2 instances to call AWS services on your behalf**. Click **Next: Permissions**.
7. Select the check box next to the IAM policy you just created. Click **Next: Review**.
8. Enter a **Role name** and **Role description**.
Example role name: `Deep_Security_Manager_Instance_Role`
9. Click **Create role**.

Next, attach the manager instance role to the manager in AWS

1. Go to the **EC2** service.
-

2. Click **Instances** on the left, and select the check box next to the EC2 instance where your Deep Security Manager is installed.
3. Click **Actions > Instance Settings > Attach/Replace IAM Role**.
4. From the **IAM role** drop-down list, select the manager instance role (`Deep_Security_Manager_Instance_Role`).
5. Click **Apply**.

You have now created a manager instance role with the correct IAM policy, and attached it to the Deep Security Manager's EC2 instance.

Next, configure the manager instance role in the manager

1. In Deep Security Manager, click **Administration** at the top.
2. Click **System Settings** on the left.
3. Click the **Advanced** tab in the main pane.
4. Scroll to the bottom and look for the **Manager AWS Identity** section.
5. Make sure **Use Manager Instance Role** is selected.

Note: If **Use Manager Instance Role** does not appear, make sure that you attached the role to the EC2 instance where Deep Security Manager is installed, and then "[Restart the Deep Security Manager](#)" on page 1694. On restart, Deep Security detects the role of the manager's EC2 instance and displays the **Use Manager Instance Role** option.

6. Click **Save**.
-

Finally, add the AWS Primary Account to the manager

1. In Deep Security Manager, click **Computers** at the top.
 2. In the main pane, click **Add > Add AWS Account**.
 3. Select **Use Manager Instance Role**.
 4. If the AWS Primary Account includes Amazon WorkSpaces, select **Include Amazon WorkSpaces** to include them with your Amazon EC2 instances. By enabling the check box, you ensure that your Amazon WorkSpaces appear in the correct location in the [tree structure](#) in Deep Security Manager and are billed at the correct rate.
 5. Click **Next**.
-

Deep Security Manager uses the manager instance role that is attached to its Amazon EC2 instance to add the AWS Primary Account's EC2 and WorkSpace instances to Deep Security Manager.

You have now added the AWS Primary Account to Deep Security Manager. The Amazon EC2 instances and Amazon WorkSpaces under this AWS account are loaded.

After completing the above tasks, proceed to [Install the agent](#) on your Amazon EC2 and WorkSpace instances if you have not done so already.

Add an AWS account using an access key

Follow the instructions below to add an AWS account to Deep Security Manager using an access key. Use an access key if your Deep Security Manager is on a server outside of AWS, or if you have tried another method and it doesn't work. For all other scenarios, we recommend you use [another method for adding AWS accounts](#). (Access keys are discouraged because the keys need to be updated periodically (for security reasons), which creates management overhead.)

Note: The term 'AWS Primary Account' will be used throughout this topic to describe the AWS account that contains the EC2 and WorkSpace instances that you want to add to the manager.

First, log in to the AWS Primary Account

1. Go to Amazon Web Services at <https://aws.amazon.com/>.
 2. Sign in using the AWS Primary Account.
-

Next, configure an IAM policy

1. In the Amazon Web Services Console, go to the **IAM** service.
2. In the left navigation pane, click **Policies**.

Note: If this is your first time on this page, you'll need to click **Get Started**.

3. Click **Create policy**.
 4. Select the **JSON** tab.
-

5. Copy the following JSON code into the text box:

```
{
  "Version": "2012-10-17",
  "Statement": [
    {
      "Sid": "cloudconnector",
      "Action": [
        "ec2:DescribeImages",
        "ec2:DescribeInstances",
        "ec2:DescribeRegions",
        "ec2:DescribeSubnets",
        "ec2:DescribeTags",
        "ec2:DescribeVpcs",
        "ec2:DescribeAvailabilityZones",
        "ec2:DescribeSecurityGroups",
        "workspaces:DescribeWorkspaces",
        "workspaces:DescribeWorkspaceDirectories",
        "workspaces:DescribeWorkspaceBundles",
        "workspaces:DescribeTags",
        "iam:ListAccountAliases",
        "iam:GetRole",
        "iam:GetRolePolicy",
        "sts:AssumeRole"
      ],
      "Effect": "Allow",
      "Resource": "*"
    }
  ]
}
```

Note: The "sts:AssumeRole" permission is required only if you plan on [adding more AWS accounts to the manager \(using cross account roles\)](#).

Note: The "iam:GetRole" and "iam:GetRolePolicy" permissions are optional, but recommended because they allow Deep Security to determine whether you have the correct policy when an update to the manager occurs that requires additional AWS permissions.

6. Click **Review policy**.
 7. Give the policy a name and description. Example name: `Deep_Security_Policy`.
 8. Click **Create policy**. Your policy is now ready to use.
-

Next, create an IAM user with an access key ID and secret

1. Go to the **IAM** service.
 2. Click **Users**.
 3. Click **Add user**.
 4. Enter a user name. Example: `Deep_Security_IAM_User`.
 5. For **Access type**, select **Programmatic access**.
 6. Click **Next: Permissions**.
 7. Click the **Attach existing policies directly** box.
 8. Find the IAM policy you just created and select the check box next to it.
 9. Click **Next: Review**.
 10. Click **Create user**. Your access key ID and secret access key are shown in the table.
 11. Copy the access key ID and secret access key to a safe location. You'll need them later.
-

Next, add the access key to the manager

1. Log in to Deep Security Manager.
 2. Click **Administration** at the top.
 3. Click **System Setting** on the left.
 4. Click the **Advanced** tab in the main pane.
 5. Scroll to the bottom and look for the **Manager AWS Identity** heading.
 6. Next to **Access Key - The Access Key of an AWS User used for the manager identity**, enter the access key of the IAM user you created previously.
 7. Next to **Secret Key - The Secret Access Key of an AWS User used for the manager identity**, enter the secret key of the IAM user that you created previously.
 8. Click **Save**.
-

Finally, add your AWS Primary Account and its access key to the manager

1. Click **Computers** at the top.
2. Click **Add > Add AWS Account**.
3. Select **Use AWS Access Keys**.
4. Enter your AWS Primary Account's IAM user **Access Key ID** and **Secret Access Key** that you created previously.
5. If your AWS Primary Account includes Amazon WorkSpaces, select **Include Amazon WorkSpaces** to include them with your Amazon EC2 instances. By enabling the check box, you ensure that your Amazon WorkSpaces appear in the correct location in the [tree structure](#) in Deep Security Manager and are billed at the correct rate.

Your AWS Primary Account's Amazon EC2 instances and Amazon WorkSpaces are loaded.

After completing the above tasks, proceed to [Install the agent](#) on your Amazon EC2 and WorkSpace instances if you have not done so already.

Add an AWS account using a cross-account role

Follow the instructions below to add an AWS account using a cross-account role. Use a cross-account role if you want to add multiple AWS accounts.

The instructions below assume you want to add AWS accounts with these names:

- AWS Primary Account
- AWS Account A

Tip: You can also add a cross-account role through the Deep Security API. See ["Add the account through the API"](#) on page 653 for details.

First, add the AWS Primary Account

- If your manager resides *inside* AWS, complete all the tasks in ["Add an AWS account using a manager instance role"](#) on page 642 to add the AWS Primary Account.
- If your manager resides *outside* AWS, complete all tasks in ["Add an AWS account using an access key"](#) on page 646 to add the AWS Primary Account.

Next, find the AWS Primary Account identifier

If you added the AWS Primary Account using a manager instance account role, do the following:

1. Make sure you're logged in to the AWS Primary Account.
2. Go to the **IAM** service.
3. Click **Roles**.
4. Find the manager instance role that you created in ["Add an AWS account using a manager instance role" on page 642](#). For example: `Deep_Security_Manager_Instance_Role`
5. Select the role in the list to reveal its details.
6. Look for the **Role ARN** field at the top of the page. Its value is similar to:
`arn:aws:iam::1111111111:role/Deep_Security_Manager_Instance_Role`
7. Note the role's account ID in the ARN. It is the number (1111111111). You'll need it later to create the cross-account role.

If you added the AWS Primary Account using an access key, do the following:

1. Make sure you're logged in to the AWS Primary Account.
2. At the top-right of AWS, click **Support > Support Center**.
3. Note the **Account Number** shown at the top-right (1111111111, in this example). You'll need it later to create the cross-account role.

Next, retrieve the external ID

1. Log in to Deep Security Manager.
2. Click **Computers** at the top.
3. Click **Add > Add AWS Account**. A wizard appears.
4. Click the eye icon next to the obscured external ID to reveal it. For more on this ID, see ["What is the external ID?" on page 657](#)
5. Copy the external ID to a secure place. You will need it in the next step to configure AWS Account A and any other AWS accounts you want to add.
6. (Optional.) Close the wizard and the manager.

Next, configure an IAM policy for AWS Account A

Note: This IAM policy is the same as the policy for the AWS Primary Account, except

it does not require the `sts:AssumeRole` permission.

1. Make sure you're logged in to AWS Account A.
2. In the Amazon Web Services Console, go to the **IAM** service.
3. In the left navigation pane, click **Policies**.

Note: If this is your first time on this page, you'll need to click **Get Started**.

4. Click **Create policy**.
5. Select the **JSON** tab.
6. Copy the following JSON code into the text box:

```
{
  "Version": "2012-10-17",
  "Statement": [
    {
      "Sid": "cloudconnector",
      "Action": [
        "ec2:DescribeImages",
        "ec2:DescribeInstances",
        "ec2:DescribeRegions",
        "ec2:DescribeSubnets",
        "ec2:DescribeTags",
        "ec2:DescribeVpcs",
        "ec2:DescribeAvailabilityZones",
        "ec2:DescribeSecurityGroups",
        "workspaces:DescribeWorkspaces",
        "workspaces:DescribeWorkspaceDirectories",
        "workspaces:DescribeWorkspaceBundles",
        "workspaces:DescribeTags",
        "iam:ListAccountAliases",
        "iam:GetRole",
        "iam:GetRolePolicy"
      ],
      "Effect": "Allow",
      "Resource": "*"
    }
  ]
}
```

Note: The "iam:GetRole" and "iam:GetRolePolicy" permissions are optional, but recommended because they allow Deep Security to determine whether you have the correct policy when an update to the manager occurs that requires additional AWS permissions.

7. Click **Review policy**.
8. Give the policy a name and description. Example name: `Deep_Security_Policy_Cross`.
9. Click **Create policy**. Your policy is now ready to use.

Next, create a cross-account role for AWS Account A

1. Make sure you're logged in to AWS Account A.
2. Go to the **IAM** service.
3. In the left navigation pane, click **Roles**.
4. In the main pane, click **Create role**.
5. Click the **Another AWS account** box.
6. In the **Account ID** field:
 - If you are using Deep Security Manager *inside* AWS, enter the account ID of AWS Primary Account that you noted in a previous step. For example:
`1111111111`
 - If you are using Deep Security Manager *outside* AWS, enter the account ID of AWS Primary Account that you noted in a previous step. For example:
`1111111111`
7. Next to **Options**, enable **Require external ID**. In the **External ID** field, enter the external ID you retrieved from the manager earlier.
8. Click **Next: Permissions**.
9. Select the IAM policy that you just created (the example name was `Deep_Security_Policy_Cross`) and then click **Next: Review**.
10. On the **Review** page, enter a role name and description. Example role name: `Deep_Security_Role_Cross`.
11. On the main role page, search for the role you just created (`Deep_Security_Role_Cross`).
12. Click it.
13. Find the **Role ARN** field at the top. It looks similar to:
`arn:aws:iam::2222222222:role/Deep_Security_Role_Cross`

14. Note the **Role ARN** value. You'll need it later.

You now have a cross-account role under AWS Account A that includes the correct policy and references the account ID or manager instance role of the AWS Primary Account.

Next, add AWS Account A to the manager

1. Log in to Deep Security Manager.
2. Click **Computers** at the top.
3. Click **Add > Add AWS Account**.
4. Select **Use Cross Account Role**.
5. Enter AWS Account A's **Cross Account Role ARN**. You noted this earlier, when you created the cross-account role. In this example, it is `arn:aws:iam::2222222222:role/Deep_Security_Role_Cross`
6. If AWS Account A includes Amazon WorkSpaces, select **Include Amazon WorkSpaces** to include them with your Amazon EC2 instances. By enabling the check box, you ensure that your Amazon WorkSpaces appear in the correct location in the [tree structure](#) in Deep Security Manager and are billed at the correct rate.
7. Click **Next**.
AWS Account A's Amazon EC2 instances and Amazon WorkSpaces are loaded.

You have now added AWS Account A to the manager.

After completing the above tasks, proceed to [Install the agent](#) on your Amazon EC2 and Workspace instances if you have not done so already.

Add the account through the API

1. If you don't yet have the external ID, call the Deep Security `/api/awconnectorsettings` endpoint to retrieve it (the `ExternalId` parameter). For more on this ID, see ["What is the external ID?" on page 657](#)
2. In AWS, specify the external ID in your cross-account role's IAM trust policy.
3. Use the `/api/awconnectors` API endpoint to add AWS accounts to Deep Security. (Do not use the `/rest/cloudaccounts/aws` API because it has been deprecated.) See <https://success.trendmicro.com/solution/000241973> for details on how long the `/rest/cloudaccounts/aws` API will continue to be supported and tips on how to move to the new endpoint.

Add Amazon WorkSpaces

Amazon WorkSpaces are virtual cloud desktops that run in Amazon Web Services (AWS). You can protect them with Deep Security following the instructions in one of these sections:

- ["Protect Amazon WorkSpaces if you already added your AWS account" below](#)
- ["Protect Amazon WorkSpaces if you have not yet added your AWS account" on the next page](#)

Note: The Deep Security Agent only supports Amazon WorkSpaces Windows desktops—it does not support Linux desktops.

After completing the steps in one of the above-mentioned sections:

- your Amazon WorkSpaces are displayed in Deep Security Manager on the left under **Computers** > *your_AWS_account* > *your_region* > **WorkSpaces**
- your Amazon WorkSpaces are protected by the Deep Security Agent

Protect Amazon WorkSpaces if you already added your AWS account

If you already added your AWS account to Deep Security Manager (to protect your Amazon EC2 instances), complete the steps in this section to configure Deep Security to work with Amazon WorkSpaces.

1. Upgrade Deep Security Manager to version 10.3 or later. See ["Install Deep Security Manager" on page 442](#).
2. Launch an Amazon WorkSpace, and then install and activate Deep Security Agent 10.2 or later on it. See ["Install the agent on Amazon EC2 and WorkSpaces" on page 522](#) for details. Optionally, create a custom WorkSpace bundle so that you can deploy it to many people. See ["Install the agent on an AML or WorkSpace bundle" on page 528](#) for details on installation, activation, and bundle creation.
3. Modify your IAM policy to include Amazon WorkSpaces permissions:
 - a. Log in to AWS with the account that was added to Deep Security Manager.
 - b. Go to the **IAM** service.
 - c. Find the Deep Security IAM policy. You can find it under **Policies** on the left, or you can look for the Deep Security IAM role or IAM user that references the policy and then click the policy within it.
 - d. Modify the Deep Security IAM policy to look like the one shown in ["Add an AWS account using a cross-account role" on page 649](#). The policy includes Amazon

WorkSpaces permissions. If you added more than one AWS account to Deep Security, the IAM policy must be updated under all the AWS accounts.

4. In Deep Security Manager, edit your AWS account:
 - a. On the left, right-click your AWS account and select **Properties**.
 - b. Enable **Include Amazon WorkSpaces**.
 - c. Click **Save**.

You have now added Amazon WorkSpaces to Deep Security.

Protect Amazon WorkSpaces if you have not yet added your AWS account

If you have not yet added your AWS account to Deep Security Manager, complete the steps in one of the following sections:

- If you want to protect existing Amazon WorkSpaces, read ["Install the agent on Amazon EC2 and WorkSpaces" on page 522](#)
- If you want to be able to launch new Amazon WorkSpaces with the agent 'baked in', read ["Install the agent on an AMI or Workspace bundle" on page 528](#).

Manage an AWS account

Topics:

- ["Edit an AWS account" below](#)
- ["Remove an AWS account" on the next page](#)
- ["Synchronize an AWS account" on the next page](#)

Edit an AWS account

You can edit an AWS account's settings in Deep Security Manager. You might need to do this if, for example, your AWS account needs to be configured to include Amazon WorkSpaces. To edit an AWS account:

1. Log in to Deep Security Manager.
2. Click **Computers** at the top.
3. On the left, right-click your AWS account name and select **Properties**.
4. Edit the settings and click **OK**.

Remove an AWS account

Removing an AWS account from Deep Security Manager permanently removes the account from the Deep Security database as well as its underlying computers. Your account with AWS is unaffected and any Deep Security Agents that were installed on the instances are still installed, running, and providing protection (although they will no longer receive security updates). If you decide to re-import computers from the AWS account, the Deep Security Agents download the latest security updates at the next scheduled opportunity.

1. In Deep Security Manager, click **Computers** at the top.
2. In the navigation panel, right-click the AWS account and select **Remove AWS Account**.
3. Confirm that you want to remove the account.

The account is removed from the Deep Security Manager.

Synchronize an AWS account

When you synchronize (sync) an AWS account, Deep Security Manager connects to the AWS API to obtain and display the latest set of AWS EC2 and WorkSpace instances.

To force a sync immediately:

1. In Deep Security Manager, click **Computers**.
2. On the left, right-click your AWS account and select **Synchronize Now**.

There is also a background sync that occurs every 10 minutes, and this interval is not configurable. If you force a sync, the background sync is unaffected and continues to occur according to its original schedule.

Manage an AWS account external ID

Note: The AWS account external ID is only used when [adding an AWS account using a cross-account role](#).

Topics:

- ["What is the external ID?" on the next page](#)
- ["Configure the external ID" on the next page](#)
- ["Update the external ID" on the next page](#)
- ["Retrieve the external ID" on page 659](#)
- ["Disable retrieval of the external ID" on page 659](#)

What is the external ID?

Along with the cross-account role ARN, the external ID is used to grant access from one AWS role to another. The external ID is provided by a third-party service that wants to assume the role of your account. If you trust that service to act on your behalf, you add that external ID to your cross-account role. In this case, Deep Security is the third-party service that is providing an external ID to you, in order to act on behalf of your AWS account. Deep Security uses this access to synchronize information from your AWS account and maintain an up-to-date record of your resources. For details, see this AWS document: [How to Use External ID When Granting Access to Your AWS Resources](#).

Notes:

- The external ID is only used when adding an AWS account using a cross-account role.
- The same external ID is used for all AWS accounts added using cross-account roles. There is one ID per tenant.

Configure the external ID

Configuring the external ID is one step in a larger process of adding a cross-account role. See ["Add an AWS account using a cross-account role" on page 649](#) for details.

Update the external ID

If you previously added an AWS account [using cross-account role](#), you might have specified a user-defined external ID. To better align with AWS best-practices, Trend Micro recommends switching to the manager-defined external ID.

Note: AWS accounts that were previously added with a user-defined external ID will continue to function as normal.

Determine whether you're using a user- or manager-defined external ID

If you're not sure whether you're currently using a user- or manager-defined external ID, follow the procedure below to find out.

1. Log in to Deep Security Manager.
2. Click **Computers**.
3. Right-click the AWS account that was added using a cross-account role and select **Properties**.

4. If an **Update** link appears next to the external ID, it means that a user-defined external ID is currently in use and should be updated. If an **Update** link does not appear, it's because the manager-defined external ID is currently in use, and no action is necessary.
 5. Repeat this procedure for each account that has been added to the manager using a cross-account role.
-

Update the external ID through the manager

1. If you have not already done so, log in to Deep Security Manager, right-click the AWS account you want to update, and select **Properties**.
2. Click the **Update** link that appears next to the external ID. The **Update** link disappears.
3. Note the external ID. You'll need it in the next step to configure the cross-account role.
4. Log in to the AWS account whose external ID you just updated. Update the cross-account role's IAM policy by replacing the old external ID with the new one.
5. Back on the properties window, click **Apply** to apply changes.

Your account's user-defined external ID has now been updated to the manager-defined one.

6. Repeat this procedure for each account that has been added to the manager using a cross-account role.
-

Update the external ID through the Deep Security API

1. If you don't already have the new manager-defined external ID, call the `/api/awconnectorsettings` endpoint to retrieve it (the `ExternalId` parameter).
 2. Log in to the AWS account where the cross-account role was configured. Update the cross-account role's IAM policy by replacing the old external ID with the new one. Repeat this step for each account that has been added to the manager using a cross-account role.
 3. Using the `/api/awconnectors` endpoint, perform an `Update` action on the account you are updating, with its `CrossAccountRoleARN` parameter set to the same role ARN as it is currently. Do not provide an external ID in the request
-

object.

Your account's user-defined external ID has now been updated to the manager-defined one.

Retrieve the external ID

There are a few ways to retrieve the external ID for use with cross-accounts.

Through the 'add account' wizard

- See "[Add an AWS account using a cross-account role](#)" on page 649 which includes a sub-section on how to retrieve the external ID through the wizard.
-

Through the Deep Security API

- Call the `/api/awsconnectorsettings` endpoint to retrieve it (the `ExternalId` parameter).
-

Disable retrieval of the external ID

You might want to disable the ability to view and retrieve the external ID in the manager to prevent unauthorized access to it. You can retrieve the ID once, store it in a safe place like your secrets manager, and then disable the retrieval for everyone else.

Note: Retrieval can be enabled again at any time.

To disable retrieval:

1. Log in to Deep Security Manager.
2. Click **Administration** at the top.
3. In the main pane, click the **Security** tab.
4. Deselect **Enable retrieval and viewing of AWS external ID**.
5. Click **Save**.

Tip: You can also use roles to prevent access to the external ID. For details, see "[Define roles for users](#)" on page 1488.

Manage AWS regions

Add an Amazon Web Services region

If the Amazon Web Services (AWS) region hosting your EC2 resources does not appear when you try to add a cloud account using the **Add AWS Cloud Account** wizard, manually add the region.

On the server that is hosting Deep Security Manager, enter the command:

1. `dsm_c -action addregion -region REGION -display DISPLAY -endpoint ENDPOINT`

where the parameters are:

Parameter	Description	Example
REGION	The Amazon Web Services identifier for the region.	ca-east-1
DISPLAY	The display string to use for the region in the Add AWS Cloud Account wizard.	Canada East (Ottawa)
ENDPOINT	The fully-qualified domain name of the Amazon Elastic Compute Cloud (EC2) endpoint to use for the region.	ec2.ca-east-1.amazonaws.com

Note: If Deep Security Manager is running on a Linux server, you must run the command with `sudo` or use a superuser account such as root.

2. If the specific AWS region requires that you import a trusted certificate (most don't), see ["Manage trusted certificates" on page 1603](#).

Viewing your Amazon Web Services regions

You can view any AWS regions that you have added using the CLI.

On the server that is hosting Deep Security Manager, enter the command:

```
dsm_c -action listregions
```

Note: If Deep Security Manager is running on a Linux server, you must run the command with `sudo` or use a superuser account such as root.

Removing an Amazon Web Services region

You can delete any AWS regions that you have added using the CLI. Any existing cloud accounts for the region will continue to work unless you remove them, but administrators won't be able to create new cloud accounts for the region.

1. On the server that is hosting Deep Security Manager, enter the command:

```
dsm_c -action listregions
```

2. Find the identifier for the that you want to remove.
3. Enter the command:

```
dsm_c -action removeregion -region REGION
```

The `REGION` parameter is required.

Parameter	Description	Example
REGION	The Amazon Web Services identifier for the region.	ca-east-1

Note: If Deep Security Manager is running on a Linux server, you must run the command with `sudo` or use a superuser account such as `root`.

Protect an account running in AWS Outposts

Deep Security supports AWS accounts running on [AWS Outposts](#).

To protect your AWS accounts in Outposts:

1. ["Add an AWS account using a manager instance role" on page 642.](#) .

Note: Once you've added your AWS account to Deep Security Manager, the **Computers** page will display the resource as part of the AWS region the Outpost is connected to. For EC2 instances, the ARN of the Outpost rack is added to the instance metadata.

2. ["Install the agent on Amazon EC2 and WorkSpaces" on page 522.](#)
3. ["Activate the agent" on page 538.](#)
4. ["Create policies" on page 696.](#)

Note: High availability is supported. For more information, see ["Install Deep Security Manager on multiple nodes" on page 488.](#)

Add Azure instances

Create an Azure app for Deep Security

In your operating environment, it may not be desirable to allow the Deep Security Manager to access Azure resources with an account that has both the Global Administrator role for Microsoft Entra ID and the Subscription Owner role for the Azure subscription. As an alternative, you can create an Azure app for the Deep Security Manager that provides read-only access to Azure resources.

Tip: If you have multiple Azure subscriptions, you can create a single Deep Security Azure app for all of them, as long as the subscriptions all connect to the same Active Directory. Details are provided within the set of instructions below.

To create an Azure app, you will need to:

1. ["Assign the correct roles" below.](#)
2. ["Create the Azure app" below.](#)
3. ["Record the Azure app ID and Active Directory ID" on the next page.](#)
4. ["Record the Subscription ID\(s\)" on page 664.](#)
5. ["Assign the Azure app a role and connector" on page 664.](#)

Assign the correct roles

To create an Azure app, your account must have the User Administrator role for Microsoft Entra ID and the User Access Administrator role for the Azure subscription. Assign these roles to your Azure account before proceeding.

Create the Azure app

1. In the **Microsoft Entra ID** blade, click **App registrations**.
2. Click **New registration**.
3. Enter a **Name** (for example, Deep Security Azure Connector).
4. For the **Supported account types**, select **Accounts in this organizational directory only**.
5. Click **Register**.

The Azure app appears in the **App registrations** list with the **Name** you chose in Step 3 (above).

Record the Azure app ID and Active Directory ID

1. In the **App registrations** list, click the Azure app.

Note: The Azure app will display with the **Name** you chose for it in Step 3 of the "[Create the Azure app](#)" on the previous page procedure.

2. Record the **Application (client) ID**.
3. Record the **Directory (tenant) ID**

Create an application secret or upload the application certificate

1. On the **Certificates & secrets** tab, choose which type of application credential to use:
 - Option 1: Client secrets (application password)
 - Option 2: Certificate

Note: You can create multiple application credentials in Azure, but Deep Security Manager only required one credential (either the application secret or application certificate) for the Azure account.

2. Follow the procedure for either Option 1 or Option 2 (below) depending on the type of credential you want to use.

Option 1: Create client secrets (application password)

1. Click **New client secret**.
2. Enter a **Description** for the client secret.
3. Select an appropriate **Duration**. The client secret expires after this time.
4. Click **Add**.

The client secret **Value** appears.

5. Record the client secret **Value**. You will use it as the Application Password when registering the Azure app with Deep Security.

Warning: The client secret **Value** only appears once, so record it now. If you do not, you must regenerate it to obtain a new **Value**.

Note: If the client secret **Value** expires, you must regenerate it and update it in the associated Azure accounts.

Option 2: Upload an application certificate

1. Prepare a certificate in X.509 PEM text format.

The certificate can be either public-signed or self-signed and should not expire. If the private key is protected with a secret, you will need the certificate private key and optional passphrase/secret when setting up the Azure account in Deep Security Manager.

Note: Deep Security Manager currently does not support certificates in binary format.

2. Click the **Upload certificate** button.
3. Select certificate file to upload.
4. Click **Add**.

Record the Subscription ID(s)

1. On the left, go to **All Services** and click **Subscriptions**.

Note: If **Subscriptions** does not appear on the left, use the search box at the top of the screen to find it.

A list of subscriptions appears.

2. Record the **Subscription ID** of each subscription you want to associate with the Azure app. You will need the ID(s) later, when adding the Azure account(s) to Deep Security.

Assign the Azure app a role and connector

1. Under **All Services > Subscriptions**, click a subscription that you want to associate with the Azure app.

Note: You can associate another subscription with the Azure app later if you want to.

2. Click **Access Control (IAM)**.
3. In the main pane, click **Add** and then select **Add Role Assignment** from the drop-down menu.
4. Under **Role**, enter `Reader` and then click the **Reader** role that appears.
5. Under **Assign access to**, select **User, user group, or service principal**.
6. Under **Select members**, enter the Azure app **Name** (for example, `Deep Security Azure Connector`).

The Azure app appears with the **Name** you chose for it in Step 3 of the "[Create the Azure app](#)" on page 662 procedure.

7. Click **Save**.
8. If you want to associate the Azure app to another subscription, repeat this procedure (["Assign the Azure app a role and connector" on the previous page](#)) for that subscription.

You can now configure Deep Security to add Azure virtual machines by following the instructions in ["Add a Microsoft Azure account to Deep Security" below](#).

Add a Microsoft Azure account to Deep Security

Once you've installed Deep Security Manager, you can add and protect Microsoft Azure virtual machines by connecting a Microsoft Azure account to the Deep Security Manager. Virtual machines appear on the Computers page, where you can manage them like any other computer.

Topics in this section:

- ["What are the benefits of adding an Azure account?" below](#)
- ["Configure a proxy setting for the Azure account" on the next page](#)
- ["Add virtual machines from a Microsoft Azure account to Deep Security" on the next page](#)
- ["Manage Azure classic virtual machines with the Azure Resource Manager connector" on page 667](#)
- ["Remove an Azure account" on page 667](#)
- ["Synchronize an Azure account" on page 668](#)

What are the benefits of adding an Azure account?

The benefits of adding an Azure account (through Deep Security Manager > **Computers** > **Add Azure Account**) instead of adding individual Azure virtual machines (through Deep Security Manager > **Computers** > **Add Computer**), are:

- Changes in your Azure virtual machine inventory are automatically reflected in Deep Security Manager. For example, if you delete a number of instances in Azure, those instances disappear automatically from the manager. By contrast, if you use **Computers** > **Add Computer**, Azure instances that are deleted from Azure remain visible in the manager until they are manually deleted.
- Virtual machines are organized into their own branch in the manager, which lets you easily see which Azure instances are protected and which are not. Without the Azure account, all your virtual machines appear at the same root level under **Computers**.

Configure a proxy setting for the Azure account

You can configure the Deep Security Manager to use a proxy server to access resources in Azure accounts. For details, see "[Connect to cloud accounts via proxy](#)" on page 1410.

Add virtual machines from a Microsoft Azure account to Deep Security

Add your Microsoft Azure account to Deep Security following the instructions below.

1. Before you begin, [create an Azure app for Deep Security](#).
2. In Deep Security Manager, go to **Computers > Add > Add Azure Account**.

Note: As of Deep Security Manager 12.0, 'Quick' mode is no longer available. If you used Quick mode in prior releases, there is no impact to your deployment. All new Azure Cloud accounts must use the advanced method.

3. Enter a **Display name**, and then enter the following Azure access information you recorded in step 1:
 - **Directory ID**
 - **Subscription ID**
 - **Application ID**

Note: If you are upgrading from the Azure classic connector to the Azure Resource Manager connector, the Display name and the Subscription ID of the existing connector will be used.

Note: If you have multiple Azure subscriptions, specify only one in the **Subscription ID** field. You can add the rest later.

4. Select the type of application credential that you want to use (**Password** or **Certificate**) and then provide the credential information:
 - For Password:
 - In the **Application Password** field, enter the client secret.
 - For Certificate:
 - Next to **Certificate**, click **Choose File** and upload the certificate.
 - Next to **Private Key**, click **Choose File** and upload the private key.
 - If the private key is protected by a password, enter it in **Private Key Password (optional)**.

Note: The certificate must be in X.509 PEM text format and must be within its validity period. Binary format is not supported.

5. Click **Next**.
6. Review the summary information, and then click **Finish**.
7. Repeat this procedure for each Azure subscription, specifying a different **Subscription ID** each time.

The Azure virtual machines will appear in the Deep Security Manager under their own branch on the **Computers** page.

Tip: You can right-click your Azure account name and select **Synchronize Now** to see the latest set of Azure VMs.

Tip: You will see all the virtual machines in the account. If you'd like to only see certain virtual machines, use smart folders to limit your results. See "[Group computers dynamically with smart folders](#)" on page 1542 for more information.

Note: If you have previously added virtual machines from this Azure account, they will be moved under this account in the Computers tree.

Manage Azure classic virtual machines with the Azure Resource Manager connector

You can also manage virtual machines that were added with the Azure classic connector with the Azure Resource Manager connector, allowing you to manage both your Azure classic and Azure Resource Manager virtual machines with a single connector.

For more information, see "[Why should I upgrade to the new Azure Resource Manager connection functionality?](#)" on the next page

1. On the **Computers** page, in the **Computers tree**, right-click the **Azure classic portal** and then click **Properties**.
2. Click **Enable Resource Manager connection**.
3. Click **Next**. Follow the corresponding procedure above.

Remove an Azure account

Removing an Azure account from the Deep Security Manager will permanently remove the account from the Deep Security database. This will not affect the Azure account. Virtual

machines with Deep Security Agents will continue to be protected, but will not receive security updates. If you later import these virtual machines from the same Azure account, the Deep Security Agents will download the latest security updates at the next scheduled update.

1. Go to the **Computers** page, right-click on the Microsoft Azure account in the navigation panel, and select **Remove Cloud Account**.
2. Confirm that you want to remove the account.
3. The account is removed from the Deep Security Manager.

Synchronize an Azure account

When you synchronize (sync) an Azure account, Deep Security Manager connects to the Azure API to obtain and display the latest set of Azure VMs.

To force a sync immediately:

1. In Deep Security Manager, click **Computers**.
2. On the left, right-click your Azure account and select **Synchronize Now**.

There is also a background sync that occurs every 10 minutes, and this interval is not configurable. If you force a sync, the background sync is unaffected and continues to occur according to its original schedule.

Why should I upgrade to the new Azure Resource Manager connection functionality?

The next time you try to add an Azure cloud account to Deep Security Manager you will be shown a message suggesting that you upgrade to the new Resource Manager connection functionality. Basically, this new functionality allows Deep Security to connect to Azure virtual machines using the Resource Manager interface. As an Azure user, you are probably aware that the new Azure deployment model Resource Manager is now the default deployment model, replacing the classic model. Since new resources are deployed using this model by default, Deep Security is only able to display these VM resources on the Computers page if it is able to communicate with the Resource Manager interface. So, if you allow Deep Security to upgrade to this new functionality then VM resources deployed with either the Resource Manager deployment model or the classic deployment model will be visible on the Computers page.

Two things to note:

- You can upgrade to this new functionality in Deep Security 10. It is already available in the new Deep Security Manager VM for Azure Marketplace console and no upgrade is

needed.

- Until you perform this upgrade VMs deployed using Resource Manager are still being fully protected by Deep Security but for you to see them on the Computers page they have to be added as a computer object. For more information, see ["Why can't I view all of the VMs in an Azure subscription in Deep Security?"](#) on page 1914

Add GCP instances

Create a Google Cloud Platform service account

Below is all the information you need to create a Google Cloud Platform (GCP) service account for use with Deep Security.

Tip: For information on why you might want to create a GCP service account to use with Deep Security Manager, see ["What are the benefits of adding a GCP account?"](#) on page 678.

Topics:

- ["Prerequisite: Enable the Google APIs" below](#)
- ["Create a GCP service account" on the next page](#)
- ["Add more projects to the GCP service account" on page 674](#)
- ["Create multiple GCP service accounts" on page 677](#)

Prerequisite: Enable the Google APIs

Before you can create a GCP service account for Deep Security Manager, you'll need to enable a few Google APIs under your existing GCP account.

Follow the procedure below to enable these APIs inside each of your projects:

1. Log in to Google Cloud Platform using your existing GCP account. This account must have access to all the GCP projects that contain VMs that you want to protect with Deep Security.
2. At the top, select a project that includes VMs that you want to add to Deep Security Manager. If you have multiple projects, you can select them later.

For example: `Project01`

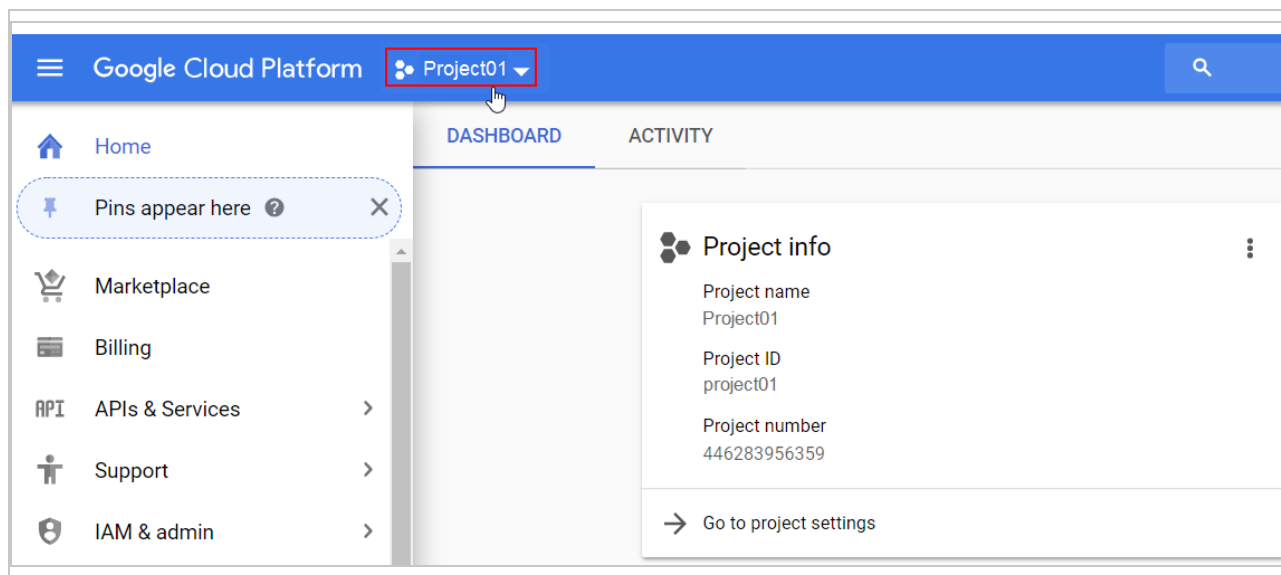

3. Click **Google Cloud Platform** at the top to make sure you're on the Home screen.
4. From the tree view on the left, select **APIs & Services > Dashboard**.
5. Click **+ ENABLE APIS AND SERVICES**.
6. In the search box, enter `cloud resource manager API` and then click the **Cloud Resource Manager API** box.
7. Click **ENABLE**.
8. Repeat steps 5 - 7 of this procedure, entering `compute engine API` and clicking the **Compute Engine API** box.
9. Repeat steps 1 - 9 of this procedure for any other projects that include VMs that you want to add to Deep Security Manager.

For more information on how to enable or disable APIs in GCP, refer to this page from Google:

<https://cloud.google.com/apis/docs/getting-started>

Create a GCP service account

Note: A service account is a special type of Google account that is associated with an application or VM, instead of an individual end user. Deep Security Manager assumes the identity of the service account to call Google APIs, so that users aren't directly involved.

Follow the procedure below to create a service account for Deep Security Manager:

1. Before you begin, make sure you've enabled the GCP APIs. See "[Prerequisite: Enable the Google APIs](#)" on the previous page.
2. Log in to Google Cloud Platform using your existing GCP account.

3. At the top, select a project. If you have multiple projects, you can select any one. For example: `Project01`.
4. Click **Google Cloud Platform** at the top to make sure you're on the Home screen.
5. From the tree view on the left, select **IAM & admin > Service accounts**.
6. Click **+ CREATE SERVICE ACCOUNT**.

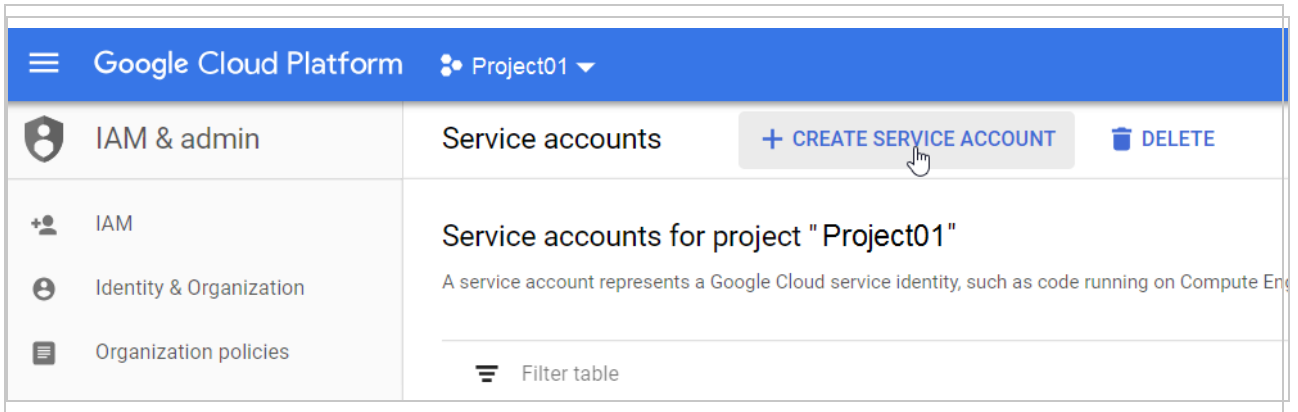

7. Enter a service account name, ID and description.

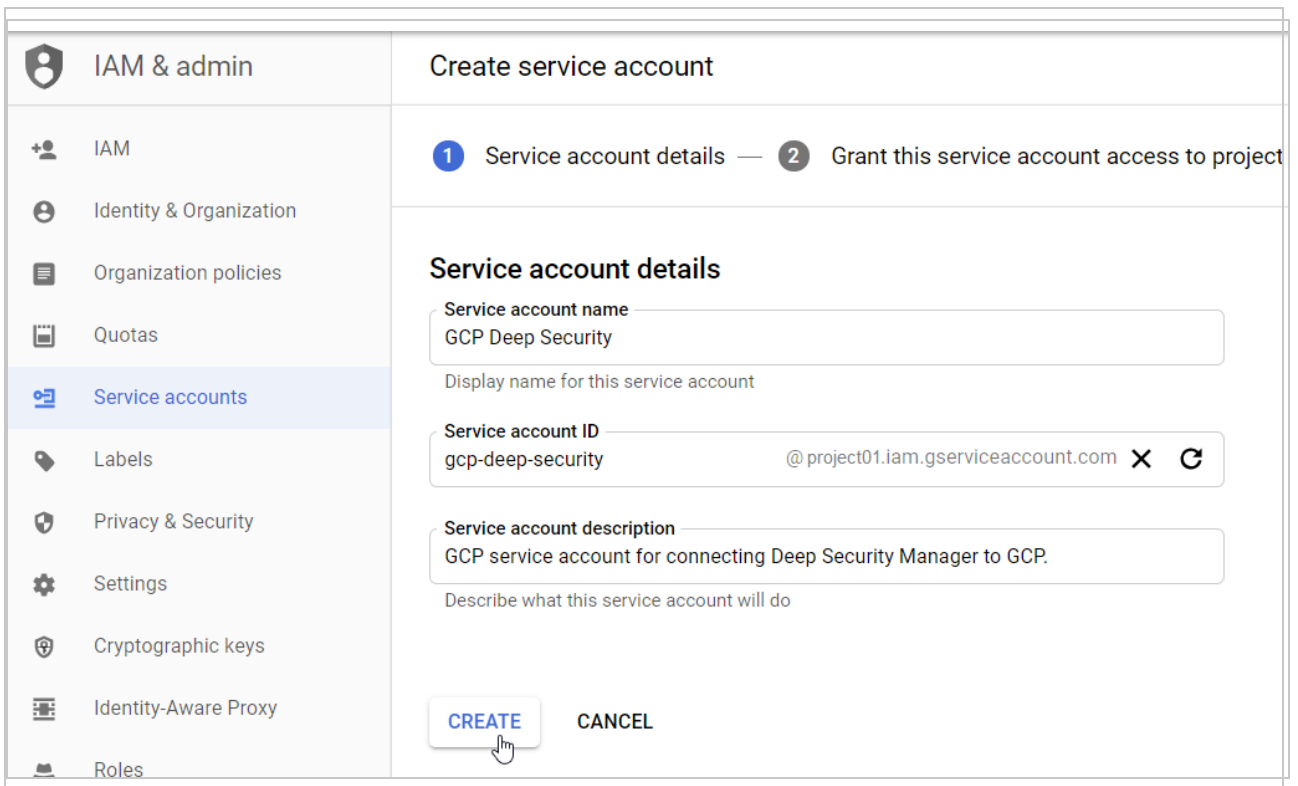

For example:

- **Service account name:** `GCP Deep Security`
 - **Service account ID:** `gcp-deep-security@<your_project_ID>.iam.gserviceaccount.com`
 - **Service account description:** `GCP service account for connecting Deep Security Manager to GCP.`
8. Click **Create**.
 9. In the **Select a role** drop-down list, select the **Compute Engine > Compute Viewer** role, or click inside the **Type to filter** area and enter `compute viewer` to find it.
 10. Click **CONTINUE**.

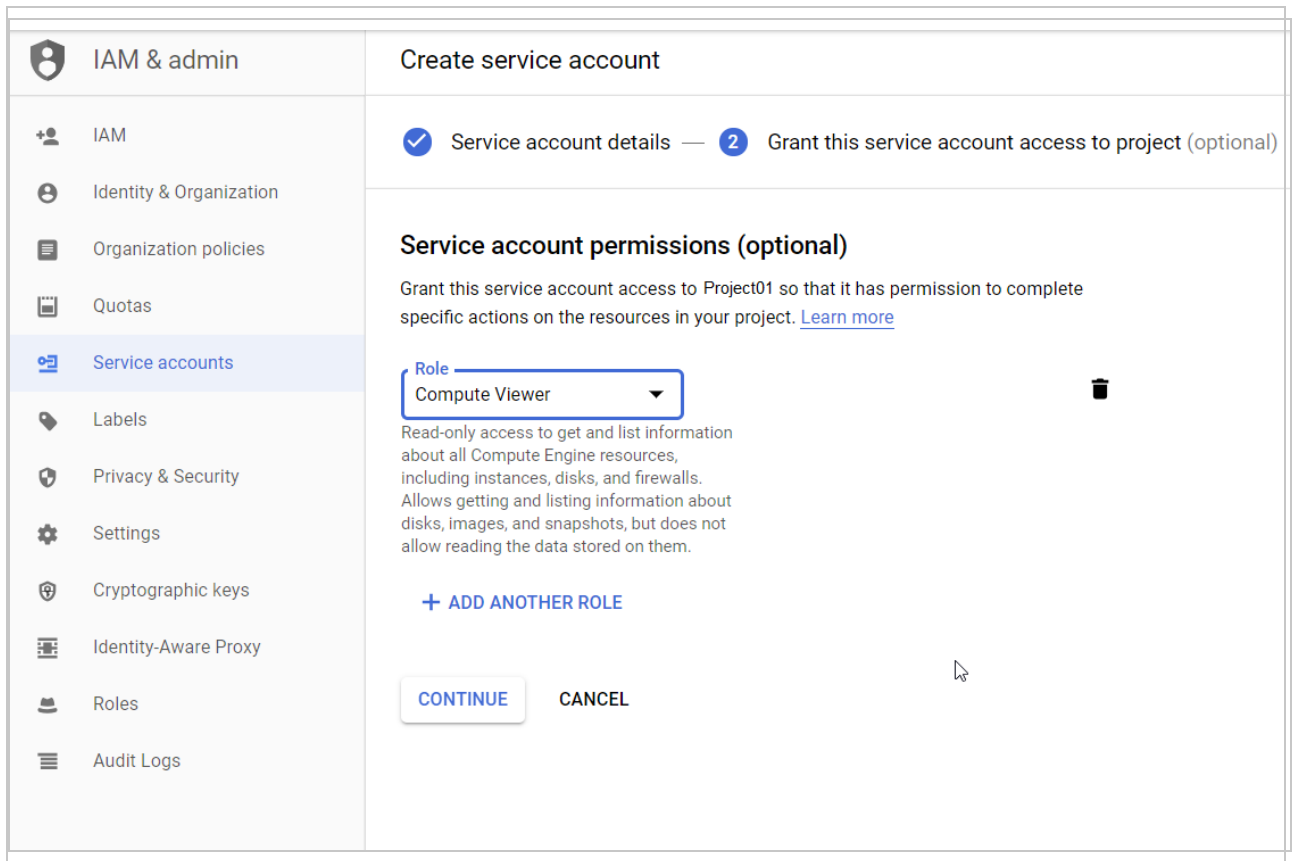

You have now assigned the Compute Viewer role.

11. Click + CREATE KEY.

The screenshot displays the 'Create service account' page within the 'IAM & admin' section. The left sidebar lists various IAM-related options, with 'Service accounts' selected. The main content area shows the 'Create service account' process, including a progress indicator for 'Service account details' and 'Grant this service account access to project'. Below this, there is a section titled 'Grant users access to this service account (optional)' with a 'Learn more' link. Two input fields are present: 'Service account users role' (with a description: 'Grant users the permissions to deploy jobs and VMs with this service account') and 'Service account admins role' (with a description: 'Grant users the permission to administer this service account'). A '+ CREATE KEY' button is highlighted with a mouse cursor, and a 'DONE' button is visible at the bottom left.

12. Select **JSON** and click **CREATE**.

Create key (optional)

Download a file that contains the private key. Store the file securely because this key can't be recovered if lost. However, if you are unsure why you need a key, skip this step for now.

Key type

JSON
Recommended

P12
For backward compatibility with code using the P12 format

CREATE **CANCEL**

The key is generated and placed in a JSON file.

13. Save the key (JSON file) to a safe place.
14. Place the JSON file in a location that is accessible to Deep Security Manager for later upload. If you need to move or distribute the file, make sure you do so using secure methods.
15. Click **DONE**.

You have now created a GCP service account with necessary roles, as well as a service account key in JSON format. The service account is created under the selected project (`Project01`), but can be associated with additional projects. For details, see the following section.

Note: It will take 60 seconds - 7 minutes for the IAM permissions to propagate through the system. See [this Google article](#) for details.

Add more projects to the GCP service account

If you have multiple projects in GCP, you must associate them with the service account you just created. All your projects (and underlying VMs) will then become visible in Deep Security

Manager when you later add the service account to Deep Security Manager.

Note: If you have many projects, you might find it easier to divide them up across multiple GCP accounts instead of adding them all to just 1, as described below. For details on a multi-GCP account setup, see ["Create multiple GCP service accounts" on page 677](#).

Follow this procedure to associate additional projects with 1 service account:

1. Before you begin, make sure you have completed the procedures in ["Prerequisite: Enable the Google APIs" on page 669](#) and ["Create a GCP service account" on page 670](#).
2. Determine the email of the GCP service account you just created, as follows:
 - a. In Google Cloud Platform, from the drop-down list at the top, select the project under which you created the GCP service account (in our example, **Project01**).
 - b. On the left, expand **IAM & Admin > Service accounts**.
 - c. In the main pane, look under the **Email** column to find the GCP service account email. For example:

```
gcp-deep-security@project01.iam.gserviceaccount.com
```

The service account email includes the name of the project under which it was created.
 - d. Note this address or copy it to the clipboard.
3. Still in Google Cloud Platform, go to *another* project by selecting it from the drop-down list at the top. For example: `Project02`.

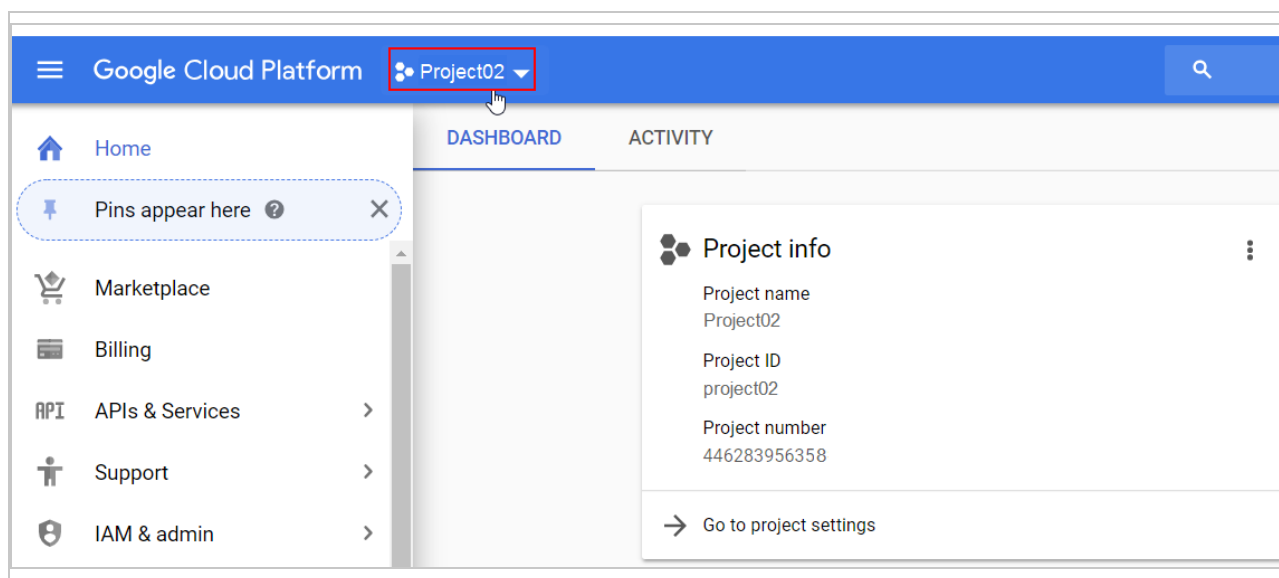

4. Click **Google Cloud Platform** at the top to make sure you're on the Home screen.

5. From the tree view on the left, click **IAM & admin > IAM**.
6. Click **ADD** at the top of the main pane.
7. In the **New members** field, paste the `Project01` GCP service account email address. For example:

```
gcp-deep-security@project01.iam.gserviceaccount.com
```

Tip: You can also start typing the email address to auto-fill the field.

8. In the **Select a role** drop-down list, select the **Compute Engine > Compute Viewer** role, or click inside the **Type to filter** area and enter `compute viewer` to find it.

Add members to "Project02"

Add members, roles to "Project02" project

Enter one or more members below. Then select a role for these members to grant them access to your resources. Multiple roles allowed. [Learn more](#)

New members

✕ ?

Role

▼ 🗑️

Read-only access to get and list information about all Compute Engine resources, including instances, disks, and firewalls. Allows getting and listing information about disks, images, and snapshots, but does not allow reading the data stored on them.

[+ ADD ANOTHER ROLE](#)

SAVE **CANCEL**

You have now added the service account with the Compute Viewer role to `Project02`.

9. Click **SAVE**.
10. Repeat steps 1 - 9 in this procedure for each project that you want to associate with the GCP service account.

For more information on how to create a service account, refer to the following page from Google:

<https://cloud.google.com/compute/docs/access/create-enable-service-accounts-for-instances>

You are now ready to add the GCP account you just created to Deep Security Manager. Proceed to ["Add a Google Cloud Platform account"](#) below.

Create multiple GCP service accounts

Normally, you would [create a single GCP service account](#) for Deep Security Manager and associate all your projects to it. This configuration is straightforward and works well for smaller organizations with fewer projects. If, however, you have a large number of projects, having them all under the same GCP service account might make them difficult to manage. In this scenario, you can divide your projects across multiple GCP service accounts. Here's how you would set this up, assuming your projects were spread across your organization's Finance and Marketing departments:

1. Create a `Finance GCP Deep Security` GCP service account for Deep Security Manager.
2. Add finance-related projects to `Finance GCP Deep Security`.
3. Create a `Marketing GCP Deep Security` GCP service account for Deep Security Manager.
4. Add marketing-related projects to `Marketing GCP Deep Security`.

For detailed instructions, see ["Create a GCP service account"](#) on page 670 and ["Add more projects to the GCP service account"](#) on page 674

5. After creating the GCP service accounts, add them to Deep Security Manager one by one, following the instructions ["Add a Google Cloud Platform account"](#) below.

Add a Google Cloud Platform account

When you add a Google Cloud Platform (GCP) account to Deep Security, all GCP VM instances associated with that account are imported into Deep Security Manager and become visible in:

- Deep Security Manager > **Computers** > *your_GCP_service_account* > *your_GCP_project*

Once imported, the GCP VM instances can be managed like any other computer.

Note: Adding a GCP account to Deep Security Manager is equivalent to [adding a GCP connector through the Deep Security API](#).

Topics:

- ["What are the benefits of adding a GCP account?" below](#)
- ["Configure a proxy setting for the GCP account" below](#)
- ["Add a GCP account to Deep Security" below](#)
- ["Remove a GCP account" on page 680](#)
- ["Synchronize a GCP account" on page 681](#)

What are the benefits of adding a GCP account?

The benefits of adding a GCP account (through Deep Security Manager > **Computers** > **Add GCP Account**) instead of adding individual GCP VMs (through Deep Security Manager > **Computers** > **Add Computer**), are:

- Changes in your GCP VM inventory are automatically reflected in Deep Security Manager. For example, if you delete a number of VM instances in GCP, those instances disappear automatically from the manager. By contrast, if you use **Computers** > **Add Computer**, GCP instances that you've deleted remain visible in the manager until you manually delete them.
- VMs are organized into projects in the manager, which lets you easily see which GCP VMs are protected and which are not. Without the GCP account, all your GCP VMs appear at the same root level under **Computers**.

Configure a proxy setting for the GCP account

Optionally, you can configure the Deep Security Manager to use a proxy server to access resources in GCP service accounts. For details, see ["Connect to cloud accounts via proxy" on page 1410](#).

Add a GCP account to Deep Security

To add a GCP account to Deep Security Manager:

1. If you have not done so already, ["Create a Google Cloud Platform service account" on page 669](#) for Deep Security.

- In Deep Security Manager, go to **Computers > Add > Add GCP Account**.

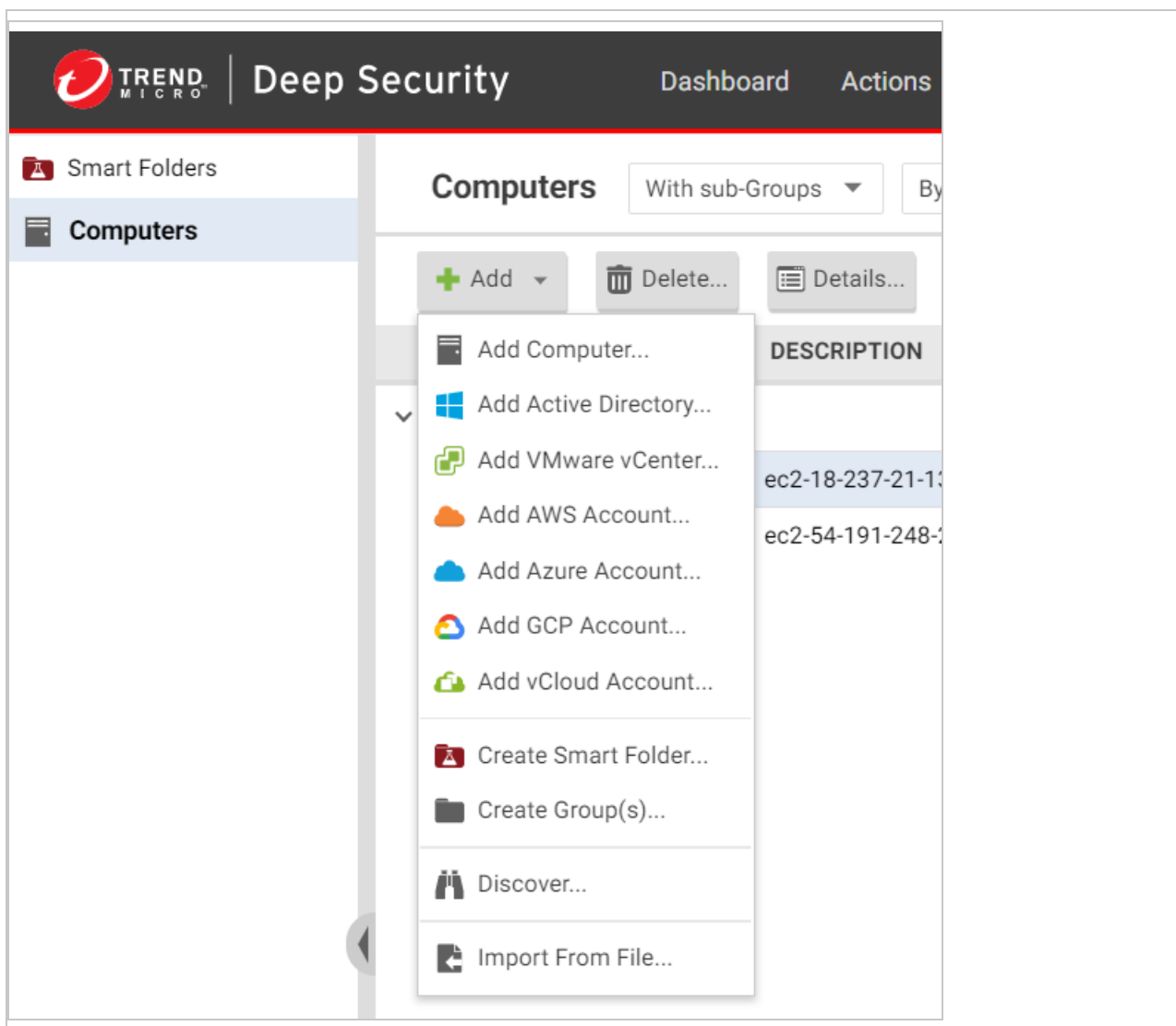

- Enter a **Display Name**. We recommend using the GCP service account name. Examples: `GCP Deep Security`, `Finance GCP Deep Security`, `Marketing GCP Deep Security`.
- Choose the **Service Account Key**. The key is a JSON file that you saved earlier, when creating the GCP service account. See ["Create a Google Cloud Platform service account" on page 669](#) for details.
- Click **Next**.
- Review the summary information, and then click **Close**.

The following occurs:

- Deep Security Manager displays your GCP service account and its associated projects in their own branch on the left side of the **Computers** page (see image below). Associated VMs are displayed in the main pane. You can right-click your GCP service account name and select **Synchronize Now** to see the latest set of GCP VMs.
- If you previously added VM instances from this service account through the **Computers > Add Computers** option (instead of the **Computers > Add GCP Account** option described here), these VMs are moved to the correct project under the service account you just added. This move occurs only for VMs that have *Deep Security Agent 12.0 or later installed*. VMs with pre-12.0 agents remain listed under the root **Computers** folder.

The following image shows the imported GCP service account, projects, and a VM.

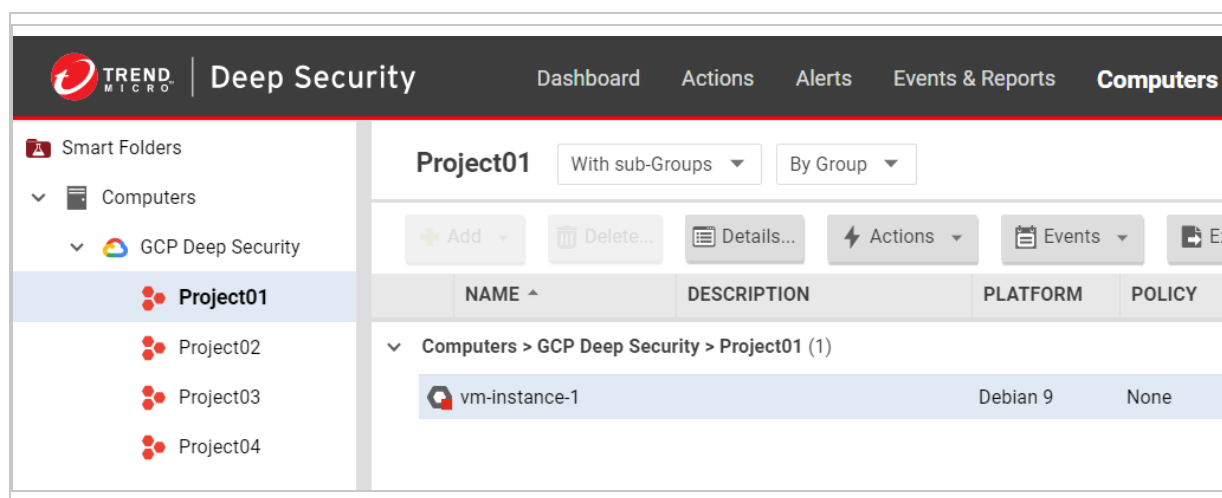

7. Repeat the steps in this procedure for each GCP service account you want to add.

You have now added a GCP service account to Deep Security Manager. Proceed to ["Install the agent on Google Cloud Platform VMs" on page 532](#) if you have not done so already.

Remove a GCP account

Removing a GCP account from the Deep Security Manager permanently removes the account from the Deep Security database. This does not affect the GCP account. VM instances with Deep Security Agents continue to be protected, but do not receive security updates. If you later reactivate Deep Security Agents on these VM instances, the Deep Security Agents will download the latest security updates at the next scheduled update.

To remove a GCP account:

1. In Deep Security Manager, click **Computers** at the top.
2. Right-click the GCP account in the tree view on the left, and select **Remove Cloud Account**.
3. Confirm that you want to remove the account.

The account is removed from the Deep Security Manager.

Synchronize a GCP account

When you synchronize (sync) a GCP account, Deep Security Manager connects to the GCP API to obtain and display the latest set of GCP VMs.

To force a sync immediately:

1. In Deep Security Manager, click **Computers**.
2. On the left, right-click your GCP account and select **Synchronize Now**.

There is also a background sync that occurs every 10 minutes, and this interval is not configurable. If you force a sync, the background sync is unaffected and continues to occur according to its original schedule.

Add VMWare VMs

Add a VMware vCenter

You can import a VMware vCenter into Deep Security Manager and then protect its virtual machines either agentlessly, with an agent, or in combined mode. (For information on those options, see "[Choose agentless vs. combined mode protection](#)" on page 548.)

Note: You cannot import a vCenter that is using vShield Manager. For information on migrating from vShield Manager to a supported VMware product, see "[Install Deep Security Manager](#)" on page 442.

You have the following options for adding a vCenter:

- "[Add a vCenter](#)" on the next page
- "[Add multiple vCenters](#)" on page 686
- "[Add a vCenter - FIPS mode](#)" on page 686

Note: Deep Security Manager supports [vCenter High Availability](#) environments in Active or Passive mode.

Add a vCenter

1. In Deep Security Manager, go to **Computers > Add > Add VMware vCenter**.

The following page appears:

Add VMware vCenter Wizard - Google Chrome

Not secure | [redacted]/VirtualWizard.screen?

Please provide the following information for the vCenter being added.

Server

Server Address:

Server Port:

Name

Name:

Description:

Credentials

Username:

Password:

< Back Next > Cancel

2. Enter vCenter information:
 - **Server Address:** The vCenter server's IP address (or host name if DNS is configured and able to resolve FQDNs to IP addresses).
 - **Server Port:** The [port number to connect to the vCenter](#) (443 by default).
 - **Name:** The name of the vCenter that will appear in the manager.
 - **Description:** A description for the vCenter.
 - **Username and Password:** Enter the user name and password of a vCenter or NSX user account. This account must conform to the specifications in the tables below, and is required to synchronize the VM inventory between vCenter and Deep Security Manager.

Note: Applying the **Read Only** or **Administrator** role at the **Hosts and Clusters** or **Virtual Machine** level in vCenter causes synchronization problems.

vCenter user account specifications

Protection method	NSX Type	vCenter user account specifications
agentless or combined mode	VMware NSX Data Center for vSphere (NSX-V)	<p>The vCenter user account must have the following two roles:</p> <ul style="list-style-type: none"> • Enterprise Administrator role assigned in NSX Manager. For information on assigning roles in NSX-V Manager, see this VMware article. • Administrator role assigned at the data center level in vCenter.
	VMware NSX-T Data Center (NSX-T)	<p>The vCenter user account must have the following role:</p> <ul style="list-style-type: none"> • Administrator role assigned at the data center level in vCenter.
agent only	No NSX-V or NSX-T integration	The vCenter user account must have the vCenter Read Only role (or another role that has equal or greater privileges) at the data center level.

3. Accept the vCenter TLS (SSL) certificate.
4. Click **Next**.

The following page appears:

The screenshot shows a web browser window titled "Add VMware vCenter Wizard - Google Chrome". The address bar shows a "Not secure" warning and the URL "VirtualWizard.screen". The main content area contains the following elements:

- A heading: "NSX Manager configuration is optional. [Learn More.](#)"
- Two radio button options:
 - Configure vCenter without NSX binding
 - Configure NSX Manager to bind with vCenter
- A section titled "NSX Manager" with two input fields:
 - Manager Address: [text input field]
 - Manager Port: [text input field]
- A section titled "Credentials" with two input fields:
 - Username: [text input field]
 - Password: [text input field]
- At the bottom right, there are three buttons: "< Back", "Next >" (highlighted in blue), and "Cancel".

Note: If you don't see the NSX binding options at the top of the page, it's because you're using an older version of the manager. Upgrade your manager to FR 2019-12-12 to see the options.

5. Fill out the page as follows:

Note: For details about the NSX-T Manager Cluster Virtual IP Address (VIP), see [NSX-T Manager Cluster Deployment with Deep Security](#).

- Select **Configure NSX Manager to bind with vCenter** and then enter your NSX information as described below if you plan on using agentless or combined mode protection. Otherwise, select **Configure vCenter without NSX binding** and click **Next**.
- **Manager Address:** The NSX Manager IP address (or host name if DNS is configured and able to resolve FQDNs to IP addresses).
- **Manager Port:** The [port number to connect to NSX Manager](#) (443 by default).

- **Username and Password:** The user name and password of an NSX or vCenter user account. This account must conform to the specifications in the table below. This user is required to synchronize NSX security policies and security groups with Deep Security Manager.

NSX user account specifications

NSX Type	User account specifications
VMware NSX Data Center for vSphere (NSX-V)	<p>The user account must be:</p> <ul style="list-style-type: none"> • the NSX built-in administrator account (which has full permissions). <p>Or</p> <ul style="list-style-type: none"> • a vCenter user account with the following two roles: <ul style="list-style-type: none"> • Enterprise Administrator role assigned in NSX Manager. For information on assigning roles in NSX-V Manager, see this VMware article. • Administrator role assigned at the data center level in vCenter. (Applying this role at the cluster level causes errors.)
VMware NSX-T Data Center (NSX-T)	<p>The user account must be:</p> <ul style="list-style-type: none"> • the NSX built-in admin account (Enterprise Admin, which has full permissions). <p>Or</p> <ul style="list-style-type: none"> • an NSX-T user account with LDAP credentials with the following roles (or other roles that have equal or greater privileges): <ul style="list-style-type: none"> • GI Partner Admin for Endpoint Protection. • Netx Partner Admin for E-W Network Introspection. <p>For details on the privileges assigned to the various VMware</p>

NSX Type	User account specifications
	roles, see this VMware article . For details on assigning roles in NSX-T Manager, see this VMware article .

6. Click **Next**.
7. Review the NSX and vCenter information and click **Finish**.
8. The **VMware vCenter has been successfully added** message is displayed. Click **Close**. The vCenter will appear on the **Computers** page.

Tip: If you select **Create an Event Based task to automatically activate VMs added to protected NSX Security Groups in this vCenter** when adding the vCenter, Deep Security Manager will create two event-based tasks. One activates VMs when protection is added and the other deactivates VMs when protection is removed. For more information, see "[Automated policy management in NSX environments](#)" on page 616.

If you provided your NSX information as described above, Deep Security Manager registers the Deep Security service within NSX Manager. The registration permits the deployment of the Deep Security service to the ESXi servers.

In a large environment with more than 3000 machines reporting to a vCenter Server, this process may take 20 to 30 minutes to complete. You can check the vCenter's Recent Task section to verify if there are activities running.

Deep Security Manager will maintain real-time synchronization with this VMware vCenter to keep the information displayed in Deep Security Manager (number of VMs, their status, etc.) up to date.

Add multiple vCenters

To add multiple vCenters to Deep Security Manager:

1. Add the first vCenter and NSX Manager following the instructions in "[Add a vCenter](#)" on [page 682](#).
2. Repeat the steps in "[Add a vCenter](#)" on [page 682](#) for subsequent vCenters and associated NSX Managers you want to add.

Add a vCenter - FIPS mode

To add a vCenter when Deep Security Manager is in [FIPS mode](#):

1. Import the vCenter and NSX Manager TLS (SSL) certificates into Deep Security Manager before adding the vCenter to the manager. See ["Manage trusted certificates" on page 1603](#).
2. Add a vCenter following the steps in ["Add a vCenter" on page 682](#). The steps are exactly the same, except that in FIPS mode you will see a Trusted Certificate section on the vCenter page. Click **Test Connection** to check whether the vCenter's SSL certificate has been imported successfully into Deep Security Manager. If there are no errors, click **Next** and continue on through the wizard.

Add virtual machines hosted on VMware vCloud

Once you have imported the resources from the cloud provider account into the Deep Security Manager, the computers in the account are managed like any computer on a local network.

To import cloud resources into Deep Security Manager, Deep Security users must first have an account with which to access the cloud provider service resources. For each Deep Security user who will import a cloud account into the Deep Security Manager, Trend Micro recommends creating a dedicated account for that Deep Security Manager to access the cloud resources. That is, users should have one account to access and control the virtual machines themselves, and a separate account for their Deep Security Manager to connect to those resources.

Note: Having a dedicated account for Deep Security ensures that you can refine the rights and revoke this account at any time. It is recommended to give Deep Security an access key or secret key with read-only rights at all times.

Note: The Deep Security Manager only requires read-only access to import the cloud resources and manage their security.

Note: When FIPS mode is enabled, you cannot add virtual machines hosted on VMware vCloud. See ["FIPS 140 support" on page 1811](#). What are the benefits of adding an Azure account?

Topics in this section:

- ["What are the benefits of adding a vCloud account?" on the next page](#)
- ["Proxy setting for cloud accounts" on the next page](#)
- ["Create a VMware vCloud Organization account for the manager" on the next page](#)
- ["Import computers from a VMware vCloud Organization Account" on page 689](#)

- ["Import computers from a VMware vCloud Air data center" on page 690](#)
- ["Configure software updates for cloud accounts" on page 690](#)
- ["Remove a cloud account" on page 691](#)

What are the benefits of adding a vCloud account?

The benefits of adding a vCloud account (through Deep Security Manager > **Computers** > **Add vCloud Account**) instead of adding individual vCloud resources (through Deep Security Manager > **Computers** > **Add Computer**), are:

- Changes in your cloud resource inventory are automatically reflected in Deep Security Manager. For example, if you delete a number of instances from vSphere, those instances disappear automatically from the manager. By contrast, if you use **Computers** > **Add Computer**, cloud instances that are deleted from vCenter remain visible in the manager until they are manually deleted.
- Cloud resources are organized into their own branch in the manager, which lets you easily see which resources are protected and which are not. Without the vCloud account, all your cloud resources appear at the same root level under **Computers**.

Proxy setting for cloud accounts

You can configure Deep Security Manager to use a proxy server specifically for connecting to instances being protected in cloud accounts. The proxy setting can be found in **Administration** > **System Settings** > **Proxies** > **Proxy Server Use** > **Deep Security Manager (Cloud Accounts - HTTP Protocol Only)**.

Create a VMware vCloud Organization account for the manager

1. Log in to VMware vCloud Director.
2. On the **System** tab, go to **Manage And Monitor**.
3. In the left navigation pane, click **Organizations**.
4. Double-click the Organization you wish to give the Deep Security user access to.
5. On the **Organizations** tab, click **Administration**.
6. In the left navigation pane, go to **Members** > **Users**.
7. Click the " plus " sign to create a new user.
8. Enter the new user's credentials and other information, and select **Organization Administrator** as the user's **Role**.

Note: **Organization Administrator** is a simple pre-defined Role you can assign to the new user account, but the only privilege required by the account is **All Rights > General > Administrator View** and you should consider creating a new vCloud role with just this permission. For more detailed information on preparing vCloud resources for Deep Security integration, see "[Deploy the appliance in a vCloud environment](#)" on page 612.

9. Click **OK** to close the new user's properties window.

The vCloud account is now ready for access by a Deep Security Manager.

Note:

To import the VMware vCloud resources into the Deep Security Manager, users will be prompted for the **Address** of the vCloud, their **User name** , and their **Password** .

The **User name** must include "@orgName". For example if the vCloud account's username is **kevin** and the vCloud Organization you've given the account access to is called **CloudOrgOne**, then the Deep Security user must enter **kevin@CloudOrgOne** as their username when importing the vCloud resources.

(For a vCloud administrator view, use **@system**.)

Import computers from a VMware vCloud Organization Account

1. In the Deep Security Manager, go to **Computers**.
2. Right-click **Computers** in the navigation panel and select **Add vCloud Account** to display the **Add vCloud Cloud Account** wizard.
3. In **Name** and **Description**, enter the resources you are adding. (These are only used for display purposes in the Deep Security Manager.)
4. In **Address**, enter the hostname or address of vCloud Director.
5. In **User Name** and **Password**, enter vCloud authentication credentials. User names should have the format **username@vcloudorganization**.
6. Click **Next**.
7. Deep Security Manager will verify the connection to the cloud resources and display a summary of the import action. Click **Finish**.

The VMware vCloud resources now appear in the Deep Security Manager under their own branch on **Computers**.

Import computers from a VMware vCloud Air data center

1. In the Deep Security Manager, go to the **Computers** section, right-click **Computers** in the navigation panel and select **Add vCloud Account** to display the **Add vCloud Account** wizard.
2. Enter a **Name** and **Description** of the vCloud Air data center you are adding. (These are only used for display purposes in the Deep Security Manager.)
3. Enter the **Address** of the vCloud Air data center.

To determine the address of the vCloud Air data center:

- a. Log in to your vCloud Air portal.
 - b. On the **Dashboard** tab, click on the data center you want to import into Deep Security. This will display the **Virtual Data Center Details** information page.
 - c. In the Related Links section of the **Virtual Data Center Details** page, click on **vCloud Director API URL**. This will display the full URL of the vCloud Director API.
 - d. Use the hostname only (not the full URL) as the Address of the vCloud Air data center that you are importing into Deep Security.
4. In **User Name** and **Password**, enter virtual data center credentials. User names should have the format **username@virtualdatacenterid**.
 5. Click **Next**.
 6. Deep Security Manager will verify the connection to the vCloud Air data center and display a summary of the import action. Click **Finish**.

The VMware vCloud Air data center now appears in the Deep Security Manager under its own branch on **Computers**.

Configure software updates for cloud accounts

Relays are modules within Deep Security Agents that are responsible for the download and distribution of Security and Software updates. Normally, the Deep Security Manager informs the relays when new updates are available, the relays get the updates and then the agents get their updates from the relays.

However, if your Deep Security Manager is in an enterprise environment and you are managing computers in a cloud environment, relays in the cloud may not be able to communicate with Deep Security Manager. You can solve this problem by allowing the relays to obtain software updates directly from the Trend Micro Download Center when they cannot connect to the Deep Security Manager. To enable this option, go to **Administration > System Settings > Updates** and under **Software Updates**, select **Allow Relays to download software updates from Trend Micro Download Center when Deep Security Manager is not accessible**.

Remove a cloud account

Removing a cloud provider account from Deep Security Manager permanently removes the account from the Deep Security database. Your account with your cloud provider is unaffected and any Deep Security agents that were installed on the instances will still be installed, running, and providing protection (although they will no longer receive security updates.) If you decide to re-import computers from the Cloud Provider Account, the Deep Security Agents will download the latest Security Updates at the next scheduled opportunity.

1. Go to the **Computers** page, right-click on the Cloud Provider account in the navigation panel, and select **Remove Cloud Account**.
2. Confirm that you want to remove the account.
3. The account is removed from the Deep Security Manager.

Change IP address or FQDN of NSX Manager

Deep Security Manager allows changing the IP address or fully qualified domain name (FQDN) for the NSX Manager when either of the following occur:

- It is impossible to directly migrate NSX-V to NSX-T (see [Migrate an agentless solution from NSX-V to NSX-T](#)).
- The NSX Manager has already been configured in Deep Security Manager.

You can change the IP address in a specific vCenter as follows:

1. Change the IP address of the NSX Manager to the virtual IP address of NSX Cluster.
2. Click **Add/Update the Certificate**.
3. Click **Test Connection** to verify the connection to the virtual IP address.
4. Click **OK** or **Apply** to finish the configuration.

Add an ESXi to a protected NSX cluster

If you have already protected ESXi servers inside a cluster with Deep Security Virtual Appliance, and you now want to add another ESXi to that cluster, read the instructions below to ensure the new ESXi server is protected.

1. Before you begin, make sure you have deployed the appliance to the cluster. See "[Deploy the appliance \(NSX-T 3.x\)](#)" on page 554 or "[Deploy the appliance \(NSX-V\)](#)" on page 589 for instructions.
2. Add the ESXi to the Data Center *but not directly to the cluster*.

3. Connect ESXi to the the virtual distributed switch (vDS) if necessary. For NSX-T, make sure the ESXi host has available NIC(s) for the NSX-T Virtual Distributed Switch (N-VDS). These NICs will be automatically configured by NSX-T Manager according to your Fabric settings.
4. Move the ESXi into the cluster. If the cluster has been configured with NSX-T, you will see the installation progress in NSX-T Manager under **System > Fabric > Host Transport Nodes**.

Once the ESXi host is moved into the cluster, NSX should automatically deploy the Deep Security service.

Note: Connecting to an NSX Manager is supported in FIPS mode. See ["FIPS 140 support" on page 1811](#).

How do I migrate to the new cloud connector functionality?

If you previously used the "Add Cloud Account" wizard to import Amazon Web Services resources into Deep Security Manager, those resources are organized by AWS region on **Computers**. You may have run the wizard more than once if you have multiple AWS regions.

The latest versions of Deep Security provide the ability to display your AWS instances under your AWS account name, organized in a hierarchy that includes the AWS Region, VPC, and subnet.

Before migrating your AWS resources, you will need to edit the policy that allows Deep Security to access your AWS account:

1. Log in to your Amazon Web Services Console and go to **Identity and Access Management (IAM)**.
2. In the left navigation pane, click **Policies**.
3. In the list of policies, select the policy that allows Deep Security to access your AWS account.
4. Go to the **Policy Document** tab and click **Edit**.
5. Edit the policy document to include this JSON code:

```
{
  "Version": "2012-10-17",
  "Statement": [
    {
      "Sid": "cloudconnector",
```

```

    "Effect": "Allow",
    "Action": [
        "ec2:DescribeImages",
        "ec2:DescribeInstances",
        "ec2:DescribeRegions",
        "ec2:DescribeSubnets",
        "ec2:DescribeTags",
        "ec2:DescribeVpcs",
        "iam:ListAccountAliases",
        "sts:AssumeRole"
    ],
    "Resource": [
        "*"
    ]
}
]
}

```

Note: The `"sts:AssumeRole"` permission is required only if you are using cross-account role access. For more information on IAM roles, see [Tutorial: Delegate Access Across AWS Accounts Using IAM Roles](#).

6. Select **Save as default version**.

To migrate your AWS resources in the Deep Security Manager:

1. In the Deep Security Manager, go to the **Computers** page.
2. In the Computers tree, right-click an AWS region and select **Upgrade to Amazon Account**.
3. Click **Finish** and then **Close**. Your AWS instances will now appear under your AWS account name, organized in a hierarchy that includes the AWS Region, VPC, and subnet.

Protect Docker containers

The benefits of a Docker deployment are real, but so is the concern about the significant attack surface of the Docker host's operating system (OS) itself. Like any well-designed software deployment, OS hardening and the use of best practices for your deployment, such as the [Center for Internet Security \(CIS\) Docker Benchmark](#), provide a solid foundation as a starting point. Once you have a secure foundation in place, adding Deep Security to your deployment gives you access to Trend Micro's extensive experience protecting physical, virtual, and cloud workloads as well as to real-time threat information from the [Trend Micro Smart Protection](#)

[Network](#). Deep Security both protects your deployment as well as helps meet and maintain continuous compliance requirements. See "[Docker compatibility](#)" on page 343 for information on supported Docker editions and releases.

Deep Security protects your Docker hosts and containers running on Linux distributions. Deep Security can do the following:

- Identify, find, and protect Docker hosts within your deployment through the use of [badges](#) and [smart folders](#)
- Protect Docker hosts and containers from vulnerabilities to [protect them against known and zero-day exploits](#) by virtually patching new found vulnerabilities
- Provide [real-time anti-malware detection](#) for the file systems used on Docker hosts and within the containers
- Assert the integrity of the Docker host for continuous compliance and to protect your deployment using the following techniques:
 - Prevent the unauthorized execution of applications on Docker hosts by helping you [control which applications are allowed to run](#) in addition to the Docker daemon
 - Monitor Docker hosts for [unexpected changes to system files](#)
 - [Notify you of suspicious events in your OS logs](#)

Note: Deep Security Docker protection works at the OS level. This means that the Deep Security Agent must be installed on the Docker host's OS, not inside a container.

Note: Communication between containers in the pod is not supported.

Beginning with Deep Security 10.1, Deep Security supports Docker in swarm mode while using an overlay network.

Deep Security protection for the Docker host

The following Deep Security modules can be used to protect the Docker host:

- Intrusion Prevention (IPS)
- Anti-Malware
- Integrity Monitoring
- Log Inspection

- Application Control
- Firewall
- Web Reputation

Deep Security protection for Docker containers

The following Deep Security modules can be used to protect Docker containers:

- Intrusion Prevention
- Anti-Malware

Limitation on Intrusion Prevention recommendation scans

Although Deep Security Intrusion Prevention controls work at the host level, it also protects container traffic on the exposed container port numbers. Since Docker allows multiple applications to run on the same Docker host, a single Intrusion Prevention policy is applied to all Docker applications. This means that recommendation scans should not be relied upon for Docker deployments.

Protect OpenShift containers

Red Hat OpenShift enables applications inside and outside Kubernetes clusters to run applications where it makes the most sense. OpenShift's basic security includes security hardening and FIPS (Federal Information Processing Standard) compliant encryption (FIPS 140-2 Level 1).

Once you have a secure foundation in place, adding Deep Security to your OpenShift deployment gives you access to Trend Micro's extensive experience protecting physical, virtual, and cloud workloads as well as to real-time threat information from the [Trend Micro Smart Protection Network](#). Deep Security both protects your deployment as well as helps meet and maintain continuous compliance requirements.

Deep Security protects your OpenShift hosts and containers running on Red Hat Linux distributions. Deep Security can do the following:

- Identify, find, and protect OpenShift hosts within your deployment
- Provide "[Enable and configure anti-malware](#)" on page 805 for the file systems used on OpenShift hosts and within the containers

Note: Communication between containers in the pod is not supported.

Deep Security protection for the OpenShift host

The following Deep Security modules can be used to protect the OpenShift host:

- Anti-Malware (excluding On-demand scan)

Deep Security protection for OpenShift containers

The following Deep Security modules can be used to protect OpenShift containers:

- Anti-Malware (excluding On-demand scan)

Configure policies

Create policies

Policies allow collections of rules and configuration settings to be saved for easier assignment to multiple computers. You can use the **Policy editor**¹ to create and edit policies that you can then apply to one or more computers. You can also use the **Computer editor**² (which is very similar to the Policy editor) to apply settings to a specific computer, but the recommended method is to create specialized policies rather than edit the settings in the Computer editor.

Tip: You can automate policy creation and configuration using the Deep Security API. For examples, see the [Create and Configure Policies](#) guide in the Deep Security Automation Center.

In this article:

- ["Create a new policy" on the next page](#)
- ["Other ways to create a policy" on the next page](#)

¹To open the Policy editor, go to the Policies page and double-click the policy that you want to edit (or select the policy and click Details).

²To open the Computer editor, go to the Computers page and double-click the computer that you want to edit (or select the computer and click Details).

- ["Edit the settings for a policy or individual computer" on the next page](#)
- ["Assign a policy to a computer" on page 699](#)
- ["Disable automatic policy updates" on page 699](#)
- ["Send policy changes manually" on page 700](#)
- ["Export a policy" on page 700](#)

Create a new policy

1. Click **Policies > New > New Policy**.
2. Enter a name for the policy. If you want the new policy to inherit its settings from an existing policy, select a policy from the **Inherit from** list. Click **Next**.

Tip: For information on inheritance, see ["Policies, inheritance, and overrides" on page 701](#).

3. Select whether you want to base this policy on an existing computer's configuration and then click **Next**.
4. If you selected **Yes** in step 3:
 - a. Select a computer to use as the basis for the new policy and click **Next**.
 - b. Specify which protection modules will be enabled for the new policy. If this policy is inheriting its settings from an existing policy, those settings will be reflected here. Click **Next**.
 - c. On the next screen, select the properties that you want to carry into the new policy and click **Next**. Review the configuration and click **Finish**.
5. If you selected **No** in step 3, specify which protection modules will be enabled for the new policy. If this policy is inheriting its settings from an existing policy, those settings will be reflected here. Click **Finish**.
6. Click **Close**. Next, you can edit the settings for the policy, as described in ["Edit the settings for a policy or individual computer" on the next page](#).

Other ways to create a policy

There are several ways to create a policies on the **Policies** page:

- Create a new policy as described above.
- Click **New > Import From File** to import policies from an XML file.
- **Note:** When importing policies, ensure that the system where you created the policies

and the system that will receive them both have the latest security updates. If the system that is receiving the policies is running an older security update, it may not have some of the rules referenced in the policies from the up-to-date system.

- Duplicate (and then modify and rename) an existing policy. To do so, right-click an existing policy you want to duplicate and then click **Duplicate**.
- Create a new policy based on a recommendation scan of a computer. To do so, go to the **Computers** page, right-click a computer and select **Actions > Scan for Recommendations**. When the scan is complete, return to the **Policies** page and click **New** to display the **New Policy** wizard. When prompted, choose to base the new policy on "an existing computer's current configuration". Then select "Recommended Application Types and Intrusion Prevention Rules", "Recommended Integrity Monitoring Rules", and "Recommended Log Inspection Rules" from among the computer's properties.
- **Note:** The Policy will consist only of recommended elements on the computer, regardless of what Rules are currently assigned to that computer.

Edit the settings for a policy or individual computer

The **Policies** page shows your existing policies in their hierarchical tree structure. To edit the settings for a policy, select it and click **Details** to open the policy editor.

These sections are available in the **Computer or Policy editor**¹:

- Overview (the "[Overview section of the policy editor](#)" on page 723 and "[Overview section of the computer editor](#)" on page 717 are different)
- [Anti-Malware](#)
- [Web Reputation](#)
- [Device Control](#)
- [Firewall](#)
- [Intrusion Prevention](#)
- [Integrity Monitoring](#)

¹You can change these settings for a policy or for a specific computer. To change the settings for a policy, go to the Policies page and double-click the policy that you want to edit (or select the policy and click Details). To change the settings for a computer, go to the Computers page and double-click the computer that you want to edit (or select the computer and click Details).

- [Log Inspection](#)
- [Application Control](#)
- [Interface Types](#)
- [Settings](#)
- [Overrides](#)

Assign a policy to a computer

1. Go to **Computers**.
2. Select your computer from the Computers list, right click and choose **Actions > Assign Policy**.
3. Select the policy from the hierarchy tree and click **OK**.

One of the following occurs:

- If you set the [communication direction](#) to **Manager Initiated** or **Bidirectional**, the policy is sent immediately to the agent computer.
- If you set the communication direction to **Agent/Appliance Initiated**, then the policy is sent when the next agent heartbeat occurs.

For more information on how child policies in a hierarchy tree can inherit or override the settings and rules of parent policies, see "[Policies, inheritance, and overrides](#)" on page 701.

After assigning a policy to a computer, you should still run periodic recommendation scans on your computer to make sure that all vulnerabilities on the computer are protected. See "[Manage and run recommendation scans](#)" on page 705 for more information.

Disable automatic policy updates

By default, any changes to a security policy are automatically sent to the computers that use the policy. You can change this so automatic sending is disabled, and you must manually send the policy.

1. Open the **Policy editor**¹ for the policy to configure.
2. Go to **Settings > General > Send Policy Changes Immediately**.

¹To open the Policy editor, go to the Policies page and double-click the policy that you want to edit (or select the policy and click Details).

3. Next to **Automatically send Policy changes to computers**, select **Yes** to allow automatic sending of policy changes. To disable automatic sending, and only allow manually sending, select **No**.
4. Click **Save** to apply the changes.

Send policy changes manually

If you make a policy change and want to send the policy changes manually to a particular computer, follow the instructions below.

1. Go to **Computers** .
2. Double-click your computer from the Computers list.
3. In the navigation pane, make sure **Overview** is selected.
4. In the main pane, click the **Actions** tab.
5. Under **Policy**, click **Send Policy**.

One of the following occurs:

- If you set the [communication direction](#) to **Manager Initiated** or **Bidirectional**, the policy is sent immediately to the agent computer.
- If you set the communication direction to **Agent/Appliance Initiated**, then the policy is sent when the next agent heartbeat occurs.

Export a policy

To export a policy to an XML file, select a policy from the policies tree and click **Export > Export Selected to XML (For Import)**.

Exported policies can only be imported by another Deep Security Manager within the same [multi-node cluster](#). If the goal is to migrate to Workload Security, see the article on how to [Migrate policies to Workload Security](#)

Note: Deep Security Manager does not support exporting and importing policies with custom rules.

Note: When you export a selected policy to XML, any child policies that the policy may have are included in the exported package. The export package contains all the actual objects associated with the policy except: intrusion prevention rules, log inspection rules, integrity monitoring rules, and application types.

Policies, inheritance, and overrides

Policies in Deep Security are intended to be created in a hierarchical structure. As an administrator, you begin with one or more base policies from which you create multiple levels of child policies that get progressively more granular in their detail. You can assign broadly applicable rules and other configuration settings at the top-level policies and then get more targeted and specific as you go down through levels of child policies, eventually arriving at rule and configuration assignments at the individual computer level.

As well as assigning more granular settings as you move down through the policy tree, you can also override settings from higher up the policy tree.

Deep Security provides a collection of policies that you can use as initial templates for the design of your own policies tailored to your environment:

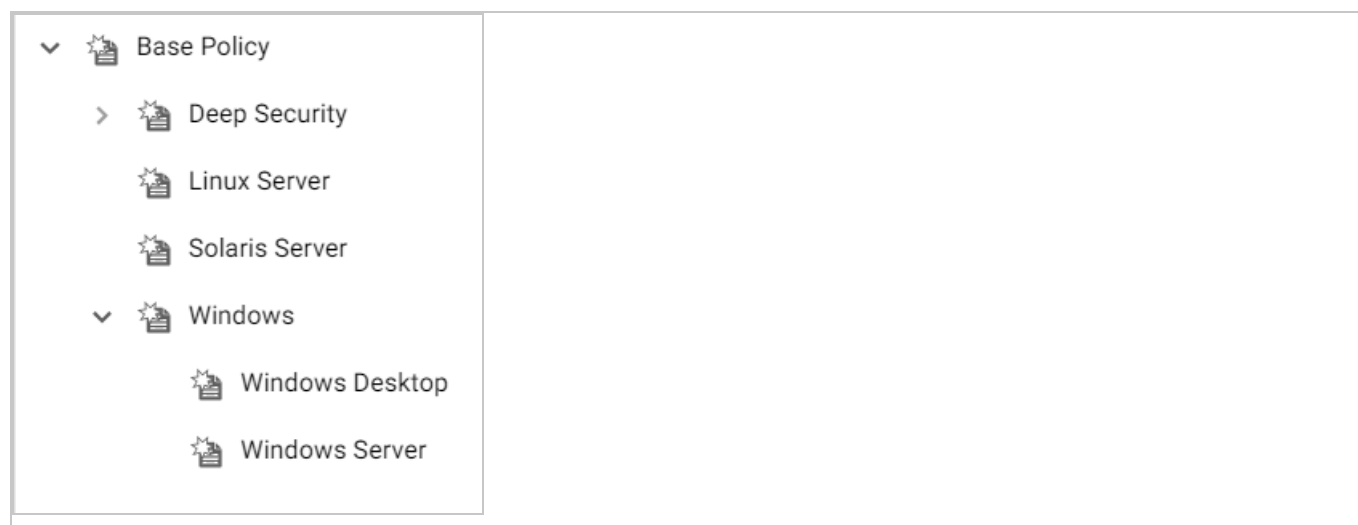

In this topic:

- ["Inheritance" below](#)
- ["Overrides" on page 703](#)
- ["View the overrides on a computer or policy at a glance" on page 704](#)

Inheritance

Child policies inherit their settings from their parent policies. This allows you to create a policy tree that begins with a base parent policy configured with settings and rules that will apply to all computers. This parent policy can then have a set of child and further descendant policies which have progressively more specific targeted settings. Your policy trees can be built based on any

kind of classification system that suits your environment. For example, the branch in the policy tree that comes with Deep Security has two child policies, one designed for a server hosting the Deep Security Manager and one designed for the Deep Security Virtual Appliance. This is a role-based tree structure. Deep Security also has three branches designed for specific operating systems, Linux, Solaris, and Windows. The windows branch has further child policies for various sub-types of Windows operating systems.

In the **Windows** policy editor on the **Overview** page, you can see that the **Windows** policy was created as a child of the **Base** policy. The policy's anti-malware setting is **Inherited (Off)**:

Policy: Base Policy > Windows Help

Overview

- Anti-Malware
- Web Reputation
- Firewall
- Intrusion Prevention
- Integrity Monitoring
- Log Inspection
- Interface Types
- Settings
- Overrides

General | Computer(s) Using This Policy | Events

Name:

Description:

Inheritance

Parent Policy:

- None
- Base Policy**
- Deep Security
- Linux Server

Modules

Anti-Malware:	Inherited (Off)	<input checked="" type="radio"/> Off
Web Reputation:	Inherited (Off)	<input type="radio"/> Off
Firewall:	Inherited (Off)	<input type="radio"/> Off, 1 rule
Intrusion Prevention:	Inherited (Off)	<input type="radio"/> Off, no rules
Integrity Monitoring:	Inherited (Off)	<input type="radio"/> Off, no rules
Log Inspection:	Inherited (Off)	<input type="radio"/> Off, no rules

This means that the setting is inherited from the parent **Base** policy, and that if you were to change the anti-malware setting in the **Base** policy from **Off** to **On**, the setting would change in the **Windows** policy as well. (The **Windows** policy setting would then read **Inherited (On)**. The value in parentheses always shows you what the current inherited setting is.)

Overrides

The **Overrides** page shows you how many settings have been overridden at this policy or specific computer level. To undo the overrides at this level, click the **Remove** button.

In this example, the **Windows Server** policy is a child policy of the **Windows** policy. Here, the anti-malware setting is no longer inherited; it is overridden and hard-set to **On**.

The screenshot displays the 'Overrides' page for a policy named 'Windows Server'. The breadcrumb navigation shows 'Policy: Base Policy > Windows > Windows Server'. The left sidebar lists various security modules, with 'Overrides' selected. The main content area is divided into three tabs: 'General', 'Computer(s) Using This Policy', and 'Events'. The 'General' tab is active, showing the policy's name, description, and inheritance details. The 'Modules' section lists several security modules with their current status and override settings:

Module	Current Status	Override Status
Anti-Malware	On	Real Time
Web Reputation	Inherited (Off)	Off
Firewall	On	On, 22 rules
Intrusion Prevention	On	Prevent, no rules
Integrity Monitoring	On	On, no rules
Log Inspection	On	On, no rules
Application Control	Inherited (Off)	Off

The 'Anti-Malware' row is highlighted with a red box. At the bottom right of the main content area, there are 'Save' and 'Close' buttons.

Tip: You can automate override checking, creation, and removal using the Deep Security API. For examples, see the [Configure Computers to Override Policies](#) guide in the Deep Security Automation Center.

Override object properties

The intrusion prevention rules that are included in this policy are copies of the intrusion prevention rules stored by the Deep Security Manager which are available for use by any other

policies. If you want to change the properties of a particular rule, you have two choices: modify the properties of the rule globally so that the changes you make apply to all instances where the rule is in use, or modify the properties locally so that the changes you make only apply locally. The default editing mode in a Computer or policy editor is **local**. If you click **Properties** on the **Assigned Intrusion Prevention Rules** area toolbar, any changes you make in the Properties window that appears will only apply locally. (Some properties like the rule name can't be edited locally, only globally.)

Right-clicking a rule displays a context menu which gives you the two Properties editing mode options: selecting **Properties** will open the local editor window and **Properties (Global)** will open the global editor window.

Most of the shared common objects in Deep Security can have their properties overridden at any level in the policy hierarchy right down to the individual computer level.

Override rule assignments

You can always assign additional rules at any policy or computer level. However, rules that are in effect at a particular policy or computer level because their assignment is inherited from a parent policy cannot be unassigned locally. They must be unassigned at the policy level where they were initially assigned.

Tip: If you find yourself overriding a large number of settings, you should probably consider branching your parent policy.

View the overrides on a computer or policy at a glance

You can see the number of settings that have been overridden on a policy or a computer by going to the **Overrides** page in the computer or policy Editor:

Policy: Base Policy > Windows > Windows Server ? Help

Overrides

Protection Module	Setting	Override Count	Action
Anti-Malware	Anti-Malware Settings	1 Override	Remove
	Malware Scan Configurations Assigned	Inherited	Remove
Web Reputation	Web Reputation Settings	Inherited	Remove
	Firewall Settings	1 Override	Remove
Firewall	Firewall Rules Overridden	Inherited	Remove
	Firewall Stateful Configurations Assigned	Inherited	Remove
	Intrusion Prevention Settings	3 Overrides	Remove
Intrusion Prevention	Intrusion Prevention Rules Overridden	Inherited	Remove
	Application Types Overridden	Inherited	Remove
Integrity Monitoring	Integrity Monitoring Settings	3 Overrides	Remove
	Integrity Monitoring Rules Overridden	Inherited	Remove
Log Inspection	Log Inspection Settings	3 Overrides	Remove
	Log Inspection Rules Overridden	Inherited	Remove
Application Control	Application Control Settings	Inherited	Remove
System			

Remove All Close

Overrides are displayed by protection module. You can revert system or module overrides by clicking the **Remove** button.

Manage and run recommendation scans

Deep Security can run recommendation scans on computers to help identify intrusion prevention, integrity monitoring, and log inspection rules that should be applied or removed.

Tip: Recommendation scans provide a good starting point for establishing a list of rules that you should implement, but there are some important additional rules that are not identified by recommendation scans. You should implement those rules manually. See ["Implement additional rules for common vulnerabilities" on page 713](#)

You can configure recommendation scans and implement the recommended rules for individual computers or at the policy level. For large deployments, Trend Micro recommends managing

recommendations through policies. This way, you can make all your rule assignments from a single source (the policy) rather than having to manage individual rules on individual computers. This can mean that some rules are assigned to computers on which they are not required; however, the minimal effect on performance is outweighed by the ease of management that results from using policies. If you enable recommendation scans in policies, use separate policies for scanning Windows and Linux computers, to avoid assigning Windows rules to Linux computers, and vice-versa.

- ["What gets scanned?" below](#)
- ["Scan limitations" on the next page](#)
- ["Adobe Reader rules recommendation" on page 708](#)
- ["Run a recommendation scan" on page 708](#)
- ["Automatically implement recommendations" on page 711](#)
- ["Check scan results and manually assign rules" on page 712](#)
- ["Configure recommended rules" on page 713](#)
- ["Implement additional rules for common vulnerabilities" on page 713](#)
- ["Troubleshooting: Recommendation Scan Failure" on page 715](#)

What gets scanned?

During a recommendation scan, Deep Security Agents scan the operating system for:

- installed applications
- the Windows registry
- open ports
- the directory listing
- the file system
- running processes and services
- environment variables
- users

The Deep Security Virtual Appliance can perform agentless recommendation scans on virtual machines but only on Windows platforms and is limited to scanning the operating system for:

- installed applications
- the Windows registry

- the file system

Scan limitations

Certain technical or logical limitations result in the rules for some types of software not being accurately recommended, or not recommended at all:

- On Unix/Linux systems, the recommendation scan engine might have trouble detecting software that is not installed through the operating system's default package manager, for example, Apache Struts, Wordpress, or Joomla. Applications installed using standard package managers are not a problem.
- On Unix/Linux systems, rules for desktop application vulnerabilities or local vulnerabilities (for example, browsers and media players) are not included in recommendation scans.
- Generic web application protection rules are not included in recommendation scans.
- Smart rules are generally not included in recommendation scans unless they address a major threat or a specific vulnerability. Smart rules address one or more known and unknown (zero-day) vulnerabilities. Rule lists in Deep Security Manager identify smart rules with "Smart" in the Type column.
- When dealing with rules related to a content management system (CMS), the recommendation scan cannot detect the CMS installation and installed version. It also cannot detect the plug-ins installed with a CMS and their versions. As a result, whenever a recommendation scan finds a web server installed and PHP installed or running on a system, all CMS-related intrusion prevention rules get recommended. This may result in the over-recommendation of rules, but balances the need for security vs. accuracy.
- The recommendations for the following web technologies may suggest more rules than necessary, so some tailoring may be required:
 - Red Hat JBoss
 - Eclipse Jetty
 - Apache Struts
 - Oracle WebLogic
 - WebSphere
 - Oracle Application Testing Suite
 - Oracle Golden Gate
 - Nginx

- OpenSSL rules are recommended on Windows only when OpenSSL is explicitly installed. If OpenSSL is being used internally by an application but it was not installed as a separate package, a recommendation scan does not detect it.
- On Linux systems, rules for Java-related vulnerabilities do not get recommended if web browsers are the only applicable vector.
- Recommendation scans cannot detect the Adobe Flash Player plug-in that is included in a default Chrome installation. Recommendations are based on the Chrome version, which means some unnecessary rules may be recommended.

Adobe Reader rules recommendation

Adobe Reader rules are often recommended and auto-applied to address Common Vulnerabilities and Exposures (CVEs). Very few of these Adobe CVEs are used in attacks and most do not have a Proof of Concept (PoC) available, but the core Adobe software remains unpatched. This has led to many rules remaining applied and could lead to performance issues.

To reduce potential performance issues caused by a large number of rules, Trend Micro will only recommend Adobe Reader rules that are either used in an attack or have a PoC made available within 1 year of the CVE being discovered. Customers are encouraged to review all recommendations for their environment.

Run a recommendation scan

Because changes to your environment can affect which rules are recommended, it's best to run recommendation scans on a regular basis (the best practice is to perform recommendation scans on a weekly basis). Trend Micro releases new intrusion prevention rules on Tuesdays, so it's recommended that you schedule recommendation scans shortly after those releases. The use of system resources, including CPU cycles, memory, and network bandwidth, increases during a recommendation scan so it's best to schedule the scans at non-peak times.

There are several ways to run recommendation scans:

- **Scheduled task:** Create a scheduled task that runs recommendation scans according to a schedule that you configure. You can assign the scheduled task to all computers, one individual computer, a defined computer group, or all computers protected by a particular policy. See ["Create a scheduled task to regularly run recommendation scans" on the next page](#).

- **Ongoing scans:** Configure a policy so that all computers protected by the policy are scanned for recommendations on a regular basis. You can also configure ongoing scans for individual computers. This type of scan checks the timestamp of the last scan that occurred and then follows the configured interval thereafter to perform future scans. This results in recommendation scans occurring at different times in your environment. This setting is helpful in environments where an agent might not be online for more than a few days (for example, in cloud environments that are building and decommissioning instances frequently). See ["Configure an ongoing scan" on the next page](#)
- **Manual scans:** Run a single recommendation scan on one or more computers. A manual scan is useful if you've recently made significant platform or application changes and want to force a check for new recommendations instead of waiting for a scheduled task. See ["Manually run a recommendation scan" on the next page](#).
- **Command line:** Initiate a recommendation scan via the Deep Security command-line interface. See ["Command-line basics" on page 1731](#).
- **API:** Initiate a recommendation scan via the Deep Security API. See ["Use the Deep Security API to automate tasks" on page 1764](#).

Note: Scheduled tasks and ongoing scans are each capable of running recommendation scans independently with their own settings. Use either the scheduled tasks or ongoing scans, but not both.

Once a recommendation scan has run, alerts are raised on the all computers for which recommendations have been made.

Create a scheduled task to regularly run recommendation scans

1. In the Deep Security Manager, go to the **Administration > Scheduled Tasks** page.
2. Click **New** on the toolbar and select **New Scheduled Task** to display the **New Scheduled Task** wizard.
3. In the **Type** list, select **Scan Computers for Recommendations** and then select how often you want the scan to occur. Click **Next**.
4. Depending on your choice in step 3, the next page lets you be more specific about the scan frequency. Make your selection and click **Next**.
5. Now select which computer(s) to scan and click **Next**.

Note: You can select all computers, choose one individual computer, select a group of computers, or select computers that are assigned a particular policy. For large

deployments, it's best to perform all actions, including recommendation scans, through policies.

6. Give a name to your new scheduled task, select whether or not to **Run Task on 'Finish'**, click **Finish**.

Configure an ongoing scan

1. In the Deep Security Manager, open the **Computer or Policy editor**¹, depending on whether you want to configure the scan for an individual computer or for all computers that are using a policy.

Note: For large deployments, it's best to perform all actions, including recommendation scans, through policies.

2. Click **Settings**. On the **General** tab, under **Recommendations**, the **Perform ongoing Recommendation Scans** setting enables or disables ongoing recommendation scans. The **Ongoing Scan Interval** setting specifies how often the scans occur. Both of those settings can be inherited from the computer or policy's parent (see "[Policies, inheritance, and overrides](#)" on page 701 for details about how inheritance works).

Manually run a recommendation scan

1. In the Deep Security Manager, go to the **Computers** page.
2. Select the computer or computers you want to scan.
3. Click **Actions > Scan for Recommendations**.

Cancel a recommendation scan

You can cancel a recommendation scan before it starts running.

1. In the Deep Security Manager, go to the **Computers** page.
2. Select the computer or computers where you want to cancel the scans.
3. Click **Actions > Cancel Recommendation Scan**.

¹You can change these settings for a policy or for a specific computer. To change the settings for a policy, go to the Policies page and double-click the policy that you want to edit (or select the policy and click Details). To change the settings for a computer, go to the Computers page and double-click the computer that you want to edit (or select the computer and click Details).

Exclude a rule or application type from recommendation scans

If you don't want a particular rule or application type to be included in recommendation scan results, you can exclude it from scans.

1. In the Deep Security Manager, open the **Computer or Policy editor**¹.

Note: For large deployments, it's best to perform all actions, including recommendation scans, through policies.

2. Depending on which type of rule you want to exclude, go to the **Intrusion Prevention**, **Integrity Monitoring**, or **Log Inspection** page.
3. On the **General** tab, click **Assign/Unassign** (for rules) or **Application Types** (for application types).
4. Double-click the rule or application type that you want to exclude.
5. Go to the **Options** tab. For rules, set **Exclude from Recommendations** to "Yes" or "Inherited (Yes)". For application types, select the **Exclude from Recommendations** checkbox.

Automatically implement recommendations

You can configure Deep Security to automatically implement recommendation scan results when it is appropriate to do so:

1. In the Deep Security Manager, open the **Computer or Policy editor**².

Note: For large deployments, it's best to perform all actions, including recommendation scans, through policies.

2. Depending on which type of rules you want to implement automatically, go to the **Intrusion Prevention**, **Integrity Monitoring**, and/or **Log Inspection** pages. (You can change the setting independently for each protection module.)
3. On the **General** tab, under **Recommendations**, change the setting to "Yes" or "Inherited (Yes)".

¹You can change these settings for a policy or for a specific computer. To change the settings for a policy, go to the Policies page and double-click the policy that you want to edit (or select the policy and click Details). To change the settings for a computer, go to the Computers page and double-click the computer that you want to edit (or select the computer and click Details).

²You can change these settings for a policy or for a specific computer. To change the settings for a policy, go to the Policies page and double-click the policy that you want to edit (or select the policy and click Details). To change the settings for a computer, go to the Computers page and double-click the computer that you want to edit (or select the computer and click Details).

Not all recommendations can be implemented automatically. The exceptions are:

- Rules that require configuration before they can be applied.
- Rules that are excluded from recommendation scans.
- Rules that have been automatically assigned or unassigned but that a user has overridden. For example, if Deep Security automatically assigns a rule and you subsequently unassign it, the rule is not reassigned after the next recommendation scan.
- Rules that have been assigned at a higher level in the policy hierarchy cannot be unassigned at a lower level. A rule assigned to a computer at the policy level must be unassigned at the policy level.
- Rules that Trend Micro has issued but which may pose a risk of producing false positives. (This will be addressed in the rule description.)

Check scan results and manually assign rules

The results of the latest recommendation scan are displayed in the **Computer or Policy editor**¹, on the **General** tab of the protection module (**Intrusion Prevention**, **Integrity Monitoring**, and **Log Inspection**).

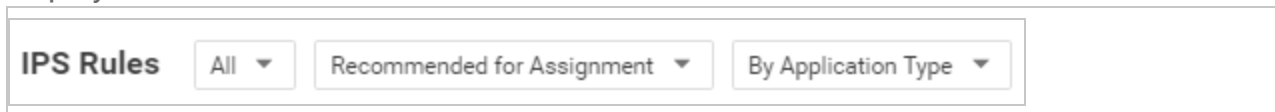

The example below describes how to deal with intrusion prevention recommendation scan results via a policy:

1. Once a recommendation scan is complete, open the policy that is assigned to the computers you have just scanned.
2. Go to **Intrusion Prevention > General**. The number of unresolved recommendations (if any) is displayed in the **Recommendations** section.
3. Click **Assign/Unassign** to open the rule assignment window.
4. Sort the rules **By Application Type** and select **Recommended for Assignment** from the display filter menu:





This displays a list of rules that are recommended for assignment but that have not been assigned.

¹You can change these settings for a policy or for a specific computer. To change the settings for a policy, go to the Policies page and double-click the policy that you want to edit (or select the policy and click Details). To change the settings for a computer, go to the Computers page and double-click the computer that you want to edit (or select the computer and click Details).



5. To assign a rule to the policy, select the checkbox next to the rule name. Rules flagged with a  icon have configuration options that you can set. Rules flagged with a  icon have settings that **must** be configured before the rule is enabled.)

Alternatively, to assign several rules at once, use the Shift or Control keys to select the rules, right-click the selection, and click **Assign Rule(s)**.

Tip: The results of a recommendation scan can also include recommendations to unassign rules. This can happen when applications are uninstalled, when security patches from a manufacturer are applied, or when unnecessary rules have been applied manually. To view rules that are recommended for unassignment, select **Recommended for Unassignment** from the display filter menu.

Note: Recommended rules are indicated by a full flag (). A partial flag () identifies an application type where only some of the rules that are part of the application type have been recommended.

Configure recommended rules

Some rules require configuration before they can be applied. For example, some log inspection rules require that you specify the location of the log files to be inspected for change. If this is the case, an alert is raised on the computer on which the recommendation has been made. The text of the alert will contain the information required to configure the rule. In the policy or computer editor, rules flagged with a  icon have configuration options that you can set. Rules flagged with a  icon have settings that **must** be configured before the rule is enabled.

Implement additional rules for common vulnerabilities

Recommendation scans provide a good starting point for establishing a list of rules that you should implement, but there are some additional rules for common vulnerabilities that are not identified by recommendation scans because they need to be carefully configured and tested before being implemented in "prevent" (block) mode. Trend Micro recommends that you configure and test these rules, then manually enable them in your policies (or for individual computers):

Tip: This list includes the most common of the additional rules you should configure. You can find others in Deep Security Manager by searching for rules whose type is "Smart" or "Policy".

Rule name	Application type
1007598 - Identified Possible Ransomware File Rename Activity Over Network Share	DCERPC Services
1007596 - Identified Possible Ransomware File Extension Rename Activity Over Network Share	DCERPC Services
1006906 - Identified Usage Of PsExec Command Line Tool	DCERPC Services
1007064 - Executable File Uploaded On System32 Folder Through SMB Share	DCERPC Services
1003222 - Block Administrative Share	DCERPC Services
1001126 - DNS Domain Blocker	DNS Client
1000608 - Generic SQL Injection Prevention See " Configure an SQL injection prevention rule " on page 897 for details.	Web Application Common
1005613 - Generic SQL Injection Prevention - 2	Web Application Common
1000552 - Generic Cross Site Scripting (XSS) Prevention	Web Application Common
1006022 - Identified Suspicious Image With Embedded PHP Code	Web Application Common
1005402 - Identified Suspicious User Agent In HTTP Request	Web Application Common
1005934 - Identified Suspicious Command Injection Attack	Web Application Common
1006823 - Identified Suspicious Command Injection Attack - 1	Web Application Common

Rule name	Application type
1005933 - Identified Directory Traversal Sequence In Uri Query Parameter	Web Application Common
1006067 - Identified Too Many HTTP Requests With Specific HTTP Method	Web Server Common
1005434 - Disallow Upload Of A PHP File	Web Server Common
1003025 - Web Server Restrict Executable File Uploads	Web Server Common
1007212 - Disallow Upload Of An Archive File	Web Server Common
1007213 - Disallow Upload Of A Class File	Web Server Common

Troubleshooting: Recommendation Scan Failure

If you are receiving a Recommendation Scan Failure on your server, follow the steps below to resolve the issue. If the issue continues to persist after troubleshooting, [create a diagnostic package from the agent](#) and contact support.

Communication

Typically for communication issues "protocol error" will appear in the body of the error message.

If you don't have open inbound firewall ports from the Deep Security Manager to the agent, open the [ports](#) or switch to agent-initiated communication. For more information, see "[Activate and protect agents using agent-initiated activation and communication](#)" on page 1460.

Server resources

Monitor the CPU and memory resources on the server. If the memory or CPU is becoming exhausted during the scan, increase the resources.

Timeout values

Increase the timeout values for the recommendation scan.

1. Open the command prompt and navigate to the Deep Security Manager installation folder.
2. Enter the commands below (if this is a multi-tenant environment, add the tenant name):

```
dsm_c -action changesetting -name  
settings.configuration.agentSocketTimeoutOverride -value 1200
```

```
dsm_c -action changesetting -name  
settings.configuration.defaultSocketChannelTimeout -value 1200000
```

```
dsm_c -action changesetting -name  
settings.configuration.recoScanKeepAliveTimeInterval -value 180000
```

3. If you are using the Deep Security Virtual Appliance, also enter these commands:

```
dsm_c -action changesetting -name  
settings.configuration.timeoutEpssecScanRequest -value 1770
```

```
dsm_c -action changesetting -name  
settings.configuration.timeoutDsamCommandChannel -value 1800
```

Detect and configure the interfaces available on a computer

The Computer and Policy editors contain an **Interfaces** (in the Computer editor) and **Interface Types** (in the Policy editor) section that displays the interfaces detected on the computer. If a policy with multiple interface assignments has been assigned to the computer, interfaces that match the patterns defined in the policy will be identified.

The **Interface Types** section of the Policy editor provides additional capabilities:

Configure a policy for multiple interfaces

If you have computers with more than one interface, you can assign various elements of a policy (firewall rules, etc.) to each interface.

1. In the Policy editor, click **Interface Types**.
2. In the Network Interface Specificity section, select **Rules can apply to specific interfaces**.
3. In the Interface Type sections that appear, type the names and pattern matching strings.

The interface type name is used only for reference. Common names include "LAN", "WAN", "DMZ", and "Wi-Fi", though any name can be used to map to your network's topology.

The interface name used for all container network interfaces and host virtual interfaces is "integrated_veth", which has a MAC address of 02:00:00:00:00:00.

The matches define a wildcard-based interface name to auto map the interfaces to the appropriate interface type. Examples would be "Local Area Connection *", "eth*", or "Wireless *". When an interface cannot be mapped automatically, an alert is triggered. You can manually map it from the **Interfaces** page in the computer editor for a particular computer.

Note: If Deep Security detects interfaces on the computer that don't match any of these entries, the manager will trigger an alert.

Enforce interface isolation

When Interface Isolation is enabled, the firewall will try to match the regular expression patterns to interface names on the local computer. To enforce interface isolation, click **Enable Interface Isolation** option on the **Policy or Computer Editor > Firewall > Interface Isolation** tab and enter string patterns that will match the names of the interfaces on a computer (in order of priority).

Warning: Before you enable Interface Isolation make sure that you have configured the interface patterns in the proper order and that you have removed or added all necessary string patterns. Only interfaces matching the highest priority pattern will be permitted to transmit traffic. Other interfaces (which match any of the remaining patterns on the list) will be "restricted". Restricted Interfaces will block all traffic unless an Allow Firewall Rule is used to allow specific traffic to pass through.

Selecting **Limit to one active interface** will restrict traffic to only a single interface even if more than one interface matches the highest priority pattern.

Note: Deep Security uses POSIX basic regular expressions to match interface names. For information on basic POSIX regular expressions, see https://pubs.opengroup.org/onlinepubs/009695399/basedefs/xbd_chap09.html#tag_09_03

Overview section of the computer editor

The computer editor **Overview** page has the following tabbed sections:

- "General tab" on the next page
- "Actions tab" on page 721
- "TPM tab" on page 722

- ["System Events tab" on page 723](#)
- ["Exceptions tab" on page 723](#)

General tab

- **Hostname:** Appears in the **Name** column on the **Computers** page. The name must be either the IP address of the computer or the hostname of the computer. Either a fully qualified hostname or a relative hostname can be used if a hostname is used instead of an IP address. You have to specify a hostname that can be resolved or a valid IP address that the Deep Security Manager can access. This is because the communication between the Deep Security Manager and the agent computers are based on the hostname. For relay-enabled agents, all of the computers within the relay group should be able to reach the specified IP address or hostname. If the Deep Security Manager cannot access the target computer the communication direction should be set to Agent/Appliance Initiated (Settings > Computer).
- **(Last IP Used: <IP_address>):** The last IP used by the computer. **Last IP Used** may not always show the IP address of the Deep Security Agent's host. Instead, it could be the IP address of a proxy, load balancer, elastic load balancer (ELB), etc., that the agent uses to communicate with Deep Security Manager.
- **Display Name:** Appears in the Display Name column and in brackets next to the Hostname value.
- **Description:** a description of the computer.
- **Platform:** Details of the computer's OS will appear here.
- **Group:** The computer group to which the computer belongs appears in the list. You can reassign the computer to any other existing computer group.
- **Policy:** The policy (if any) that has been assigned to this computer.

Note: Keep in mind that if you unassign a policy from a computer, rules may still be in effect on the computer if they were assigned independently of the policy.

- **Asset Importance:** Deep Security Manager uses a ranking system to quantify the importance of security events. Rules are assigned a severity level (high, medium, low, etc.), and assets (computers) are assigned an "asset importance" level. These levels have numerical values. When a rule is triggered on a computer the asset importance value and the severity level value are multiplied together. This produces a score which is used to sort events by importance. (Event ranking can be seen in the **Events** pages.) Use this **Asset Importance** list to assign an asset importance level to this computer. (To edit the

numerical values associated with severity and importance levels, go to **Administration > System Settings > Ranking.**)

- **Download Security Updates From:** Use the dropdown list to select which relay group the agent/appliance on this computer will download security updates from. (not displayed if agent is acting as a relay.)

Computer status

The Status area displays the latest available information about the computer and the protection modules in effect on it. Whether the computer is protected by an agent or an appliance (or both in the case of combined mode) is displayed in the top row.

- **Status:**
 - When the computer is unmanaged the status represents the state of the agent or appliance with respect to activation. The status will display either "Discovered" or "New" followed by the agent or appliance state in brackets ("No Agent/Appliance", "Unknown", "Reactivation Required", "Activation Required", or "Deactivation Required").
 - When the computer is managed and no computer errors are present, the status will display "Managed" followed by the state of the agent or appliance in brackets ("Online" or "Offline").
 - When the computer is managed and the agent or appliance is in the process of performing an action (e.g. "Integrity Scan in Progress", "Upgrading Agent (Install Program Sent)", etc.) the task status will be displayed.
 - When there are errors on the computer (e.g., "Offline", "Update Failed", etc.) the status will display the error. When more than one error is present, the status will display "Multiple Errors" and each error will be listed beneath.

Protection module status

With Deep Security 9.5 and later, protection modules are deployed to agents on an as-needed basis. Only core functionality is included when an agent is first installed.

The **Status** area provides information about the state of the Deep Security modules. The status reflects the state of a module on the agent as well as its configuration in Deep Security Manager. A status of "On" indicates that the module is configured in Deep Security Manager and is installed and operating on the Deep Security Agent.

A green status light is displayed for a module when it is "On" and working. In addition, modules that allow individual rule assignment must have at least one rule assigned before they will display a green light.

- **Anti-Malware:** Whether Anti-Malware protection is on or off and whether it is configured for real-time or on-demand scans.
- **Web Reputation:** Whether Web Reputation is on or off.
- **Device Control:** Whether Device Control is on or off.
- **Firewall:** Whether the Firewall is on or off and how many rules are in effect.
- **Intrusion Prevention:** Whether Intrusion Prevention is on or off and how many rules are in effect.
- **Integrity Monitoring:** Whether Integrity Monitoring is on or off and how many rules are in effect.
- **Log Inspection:** Whether Log Inspection is on or off and how many rules are in effect.
- **Application Control:** Whether Application Control is on or off.
- **Scanner (SAP):** Status of the Deep Security Scanner SAP feature.
- **Online:** Indicates whether the manager can currently communicate with the agent or appliance.
- **Last Communication:** The last time the manager successfully communicated with the agent or appliance on this computer.
- **Check Status:** This button allows you to force the manager to perform an immediate heartbeat operation to check the status of the agent or appliance. Check Status will not perform a security update of the agent or appliance. When manager to agent or appliance communications is set to "Agent/Appliance Initiated" the **Check Status** button is disabled. Checking status will not update the logs for this computer. To update the logs for this computer, go to the **Actions** tab.
- **Clear Warnings/Errors:** Dismisses any alerts or errors on this computer.
- **ESXi server:** If the computer is a virtual machine protected by a virtual appliance, the ESXi server that hosts them is displayed.
- **Appliance:** If the computer is a virtual machine protected by a virtual appliance, the protecting appliance is displayed.
- **ESXi Version:** If the computer is an ESXi server, the ESXi version number is displayed.
- **Filter Driver version:** If the computer is an ESXi server, the filter driver version number is displayed. If you are using Deep Security Virtual Appliance 10.0 or later with ESXi 6.0 or later, "N/A" will be displayed because no filter driver is in use.

- **Guests:** If the computer is an ESXi server, the virtual appliance and guests are displayed.
- **Appliance Version:** If the computer is a virtual appliance, the appliance version number is displayed.
- **Protected Guests On:** If the computer is a virtual appliance, the IP of the ESXi server and the protected guest are displayed.

VMware virtual machine summary

This section displays a summary of hardware and software configuration information about the virtual machine on which the agent or appliance is running (VMware virtual machines only).

Actions tab

Activation

A newly installed Deep Security agent or appliance needs to be "activated" by the Deep Security Manager before policies, rules, requests for event logs, etc. can be sent to it. The activation procedure includes the exchange of SSL keys which uniquely identify a manager (or one of its nodes) and an agent/appliance to each other. Once activated by a Deep Security Manager, an agent/appliance will only accept instructions or communicate with the Deep Security Manager which activated it (or one of its nodes).

An unactivated agent or appliance can be activated by any Deep Security Manager.

Agents and appliances can only be deactivated locally on the computer or from the Deep Security Manager which activated it. If an agent or appliance is already activated, the button in this area will read **Reactivate** rather than **Activate**. Reactivation has the same effect as activation. A reactivation will reset the agent or appliance to the state it was in after first being installed and initiate the exchange of a new set of SSL keys.

Policy

When you change the configuration of an agent or appliance on a computer using the Deep Security Manager (apply a new Intrusion Prevention rule, change logging settings, etc.) the Deep Security Manager has to send the new information to the agent or appliance. This is a "Send Policy" instruction. Policy updates usually happen immediately but you can force an update by clicking the **Send Policy** button.

Agent Software

This displays the version of the agent or appliance currently running on the computer. If a newer version of the agent or appliance is available for the computer's platform you can click the **Upgrade Agent** or **Upgrade Appliance** button to remotely upgrade the agent or appliance from the Deep Security Manager. You can configure the Deep Security Manager to trigger an alert if new versions of the agent or appliance software running on any of your computers by going to the **Administration > System Settings > Updates** tab.

Note: Before updating or uninstalling a Deep Security Agent or Relay on Windows, you must disable agent self-protection. To do this, on the Deep Security Manager, go to **Computer editor¹ > Settings > General**. In **Agent Self Protection**, and then either deselect **Prevent local end-users from uninstalling, stopping, or otherwise modifying the Agent** or enter a password for local override.

Support

The **Create Diagnostic Package** button creates a snapshot of the state of the agent or appliance on the computer. Your support provider may request this for troubleshooting purposes.

If you have lost communication with the computer, a diagnostics package can be created locally. For more information, see "[Create a diagnostic package and logs](#)" on page 1951.

TPM tab

Note: The TPM tab will appear in place of the Actions tab for ESXi servers.

A Trusted Platform Module (TPM) is a type of chip that is used for hardware authentication. VMware uses the TPM with its ESXi hypervisors. During the boot sequence, an ESXi writes a SHA-1 hash of each hypervisor component to a set of registers as it loads. An unexpected change in these values from one boot sequence to the next can indicate a possible security issue worth investigating. Deep Security can monitor the TPM on an ESXi after every boot and raise an Alert if it detects any changes. If you select the option to enable TPM monitoring on an ESXi that doesn't support it, the option will be automatically disabled.

Enable TPM Monitoring: Select to enable Trusted Platform Module monitoring.

¹To open the Computer editor, go to the Computers page and double-click the computer that you want to edit (or select the computer and click Details).

Raise an alert when TPM Monitoring fails to obtain valid register values: Select to have Deep Security raise an alert if the Trusted Platform Module fails to obtain valid register values for the hypervisor components during the ESXi boot sequence.

TPM Register Data Imported: Indicates whether the Trusted Protection Module data has been imported.

TPM Last Checked: Indicates when the Trusted Protection Module was last checked. You can click **Check Now** to start a check of the Trusted Platform Module.

Note: The minimum requirements for TPM monitoring are

- TPM/TXT installed and enabled on the ESXi (consult your VMware documentation for details)
- The Deep Security Integrity Monitoring and Application Control modules must be properly licensed.

System Events tab

For information about events, see "[System events](#)" on page 1298.

Exceptions tab

USB Device Exception rule count limitation

The current supported USB device exception rule count for each computer is 1000.

Overview section of the policy editor

The Overview section of the policy editor has the following tabbed sections:

- "[General tab](#)" below
- "[Computer\(s\) Using This Policy tab](#)" on the next page
- "[Events tab](#)" on the next page
- "[Exceptions tab](#)" on the next page

General tab

General

- **Name:** Appears in the Display Name column and in brackets next to the Hostname value.
- **Description:** a description of the computer.

Inheritance

Identifies the parent policy (if any) from which the current policy inherits its settings.

Modules

- **Anti-Malware:** Whether anti-malware protection is on or off and whether it is configured for real-time or on-demand scans.
- **Web Reputation:** Whether web reputation is on or off.
- **Device Control:** Whether Device Control is on or off.
- **Firewall:** Whether the firewall is on or off and how many rules are in effect.
- **Intrusion Prevention:** Whether intrusion prevention is on or off and how many rules are in effect.
- **Integrity Monitoring:** Whether integrity monitoring is on or off and how many rules are in effect.
- **Log Inspection:** Whether log inspection is on or off and how many rules are in effect.
- **Application Control:** Whether application control is on or off.

Computer(s) Using This Policy tab

Lists computers to which this policy has been assigned.

Events tab

For information about events, see "[System events](#)" on page 1298.

Exceptions tab

USB Device Exception rule count limitation

The current supported USB device exception rule count for each computer is 1000.

Network engine settings

To edit the network engine settings of a policy or computer, open the **Policy editor**¹ or the **Computer editor**² for the policy or computer to configure and click **Settings > Advanced** .

Note: The **Advanced** tab also contains **Events** settings. For information on those settings, see "[Limit log file sizes](#)" on page 1131. It also contains the **Generate an Alert when Agent configuration package exceeds maximum size** setting, which controls the display of the **Agent configuration package too large** setting.

The following settings are available:

- **Network Engine Mode** : The network engine is a component within the Intrusion Prevention, Firewall, and Web Reputation modules that decides whether to block or allow packets. For the Firewall and Intrusion Prevention modules, the network engine performs a packet sanity check and also makes sure each packet passes the Firewall and Intrusion Prevention rules (called, rules matching). The network engine can operate inline or in tap mode. When operating inline, the packet stream passes through the network engine and is either dropped or passed based on the rules you've set. Stateful tables are maintained, Firewall rules are applied and traffic normalization is carried out so that Intrusion Prevention and Firewall rules can be applied. When operating in tap mode, the packet is always passed, with the exception of driver hooking issue or interface isolation. In tap mode, packet delay is also introduced, which can create a drop in throughput.

¹To open the Policy editor, go to the Policies page and double-click the policy that you want to edit (or select the policy and click Details).

²To open the Computer editor, go to the Computers page and double-click the computer that you want to edit (or select the computer and click Details).

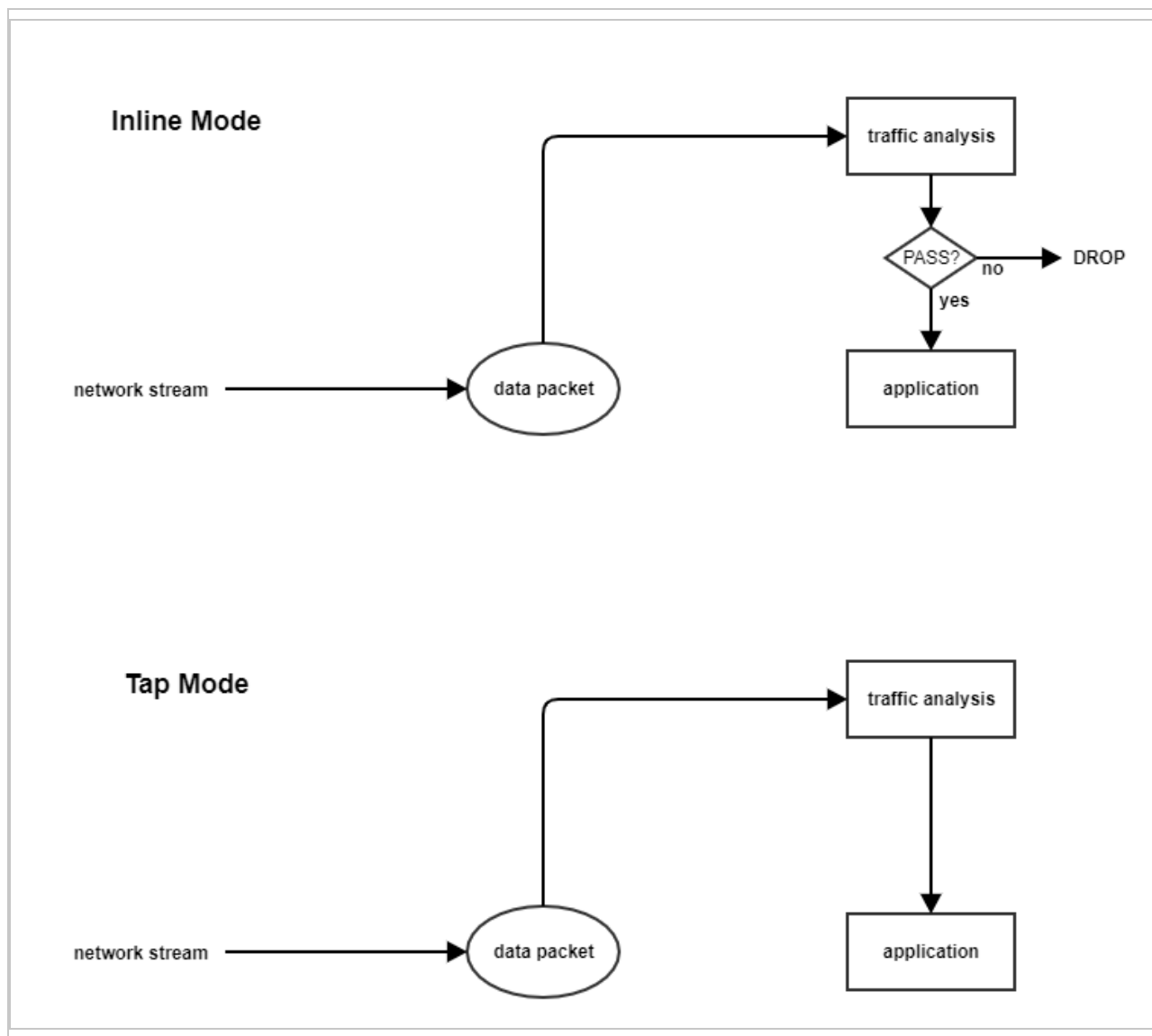

- **Network Engine Status Check:** This setting determines if the agent will monitor the status of the Network Engine. This is enabled by default, but can be disabled. For related events, see [Network Engine Status \(Windows OS\)](#).
- **Failure Response:** The settings here determine how the network engine behaves when it finds faulty packets. The default is to block them (Fail closed), but you can let some of them through (Fail open) for the reasons explained below.
 - **Network Engine System Failure:** This setting determines whether the network engine blocks or allows faulty packets that occur as a result of system failures on the network engine host, such as out of memory failures, allocated memory failures, and network engine (DPI) decoding failures occur. The options are:

- **Fail closed** (default): The network engine blocks the faulty packet. It does not perform rules matching. This option provides the highest level of security.
- **Fail open**: The network engine allows the faulty packet through, does not perform rules matching, and logs an event. Consider using **Fail open** if your agent or virtual appliance frequently encounters network exceptions because of heavy loads or lack of resources.
- **Network Packet Sanity Check Failure**: This setting determines whether the network engine blocks or allows packets that fail the packet sanity checks. Examples of sanity check failures: Firewall sanity check failures, network layer 2, 3, or 4 attribute check failures, TCP state check failures. The options are:
 - **Fail closed** (default): The network engine blocks the failed packet. It does not perform any rules matching. This option provides the highest level of security.
 - **Fail open**: The network engine allows the failed packet, does not perform any rules matching on it, and logs an event. Consider using **Fail open** if you want to disable the packet sanity checks, but preserve rules matching functionality.
- **Anti-Evasion Posture**: The anti-evasion setting controls the network engine handling of abnormal packets that may be attempting to evade analysis. For details, see "[Configure anti-evasion settings](#)" on page 921.
- **Advanced Network Engine Options**: If you deselect the **Inherited** check box, you can customize these settings:
 - **CLOSED timeout**: For gateway use. When a gateway passes on a "hard close" (RST), the side of the gateway that received the RST will keep the connection alive for this amount of time before closing it.
 - **SYN_SENT Timeout**: How long to stay in the SYN-SENT state before closing the connection.
 - **SYN_RCVD Timeout**: How long to stay in the SYN_RCVD state before closing the connection.
 - **FIN_WAIT1 Timeout**: How long to stay in the FIN-WAIT1 state before closing the connection.
 - **ESTABLISHED Timeout**: How long to stay in the ESTABLISHED state before closing the connection.
 - **ERROR Timeout**: How long to maintain a connection in an Error state. (For UDP connections, the error can be caused by any of a variety of UDP problems. For TCP connections, the errors are probably due to packets being dropped by the Firewall.)

- **DISCONNECT Timeout:** How long to maintain idle connections before disconnecting.
- **CLOSE_WAIT Timeout:** How long to stay in the CLOSE-WAIT state before closing the connection.
- **CLOSING Timeout:** How long to stay in the CLOSING state before closing the connection.
- **LAST_ACK Timeout:** How long to stay in the LAST-ACK state before closing the connection.
- **ACK Storm timeout:** The maximum period of time between retransmitted ACKs within an ACK Storm. In other words, if ACKs are being retransmitted at a lower frequency than this timeout, they will NOT be considered part of an ACK Storm.
- **Boot Start Timeout:** For gateway use. When a gateway is booted, there may already exist established connections passing through the gateway. This timeout defines the amount of time to allow non-SYN packets that could be part of a connection that was established before the gateway was booted to close.
- **Cold Start Timeout:** Amount of time to allow non-SYN packets that could belong to a connection that was established before the stateful mechanism was started.
- **UDP Timeout:** Maximum duration of a UDP connection.
- **ICMP Timeout:** Maximum duration of an ICMP connection.
- **Allow Null IP:** Allow or block packets with no source or destination IP address.
- **Block IPv6 on Agents and Appliances versions 8 and earlier:** Block or Allow IPv6 packets on older version 8.0 agents and appliances.

Deep Security Agents and Appliances versions 8.0 and older are unable to apply Firewall or DPI rules to IPv6 network traffic and so the default setting for these older versions is to block IPv6 traffic.

- **Block IPv6 on Agents and Appliances versions 9 and later:** Block or Allow IPv6 packets on agents and appliances that are version 9 or later.
- **Connection Cleanup Timeout:** Time between cleanup of closed connections (see next).
- **Maximum Connections per Cleanup:** Maximum number of closed connections to cleanup per periodic connection cleanup (see previous).
- **Block Same Src-Dest IP Address:** Block or allow packets with same source and destination IP address. (Doesn't apply to loopback interface.)
- **Maximum TCP Connections:** Maximum simultaneous TCP Connections.

- **Maximum UDP Connections:** Maximum simultaneous UDP Connections.
- **Maximum ICMP Connections:** Maximum simultaneous ICMP Connections.
- **Maximum Events per Second:** Maximum number of events that can be written per second.
- **TCP MSS Limit:** TCP MSS is a parameter in the TCP header that defines the maximum segment size of TCP segments, in bytes. The TCP MSS Limit setting defines the minimum value allowed for TCP MSS parameter. Having a lower limit for this parameter is important because it prevents kernel panic and denial of service (DoS) attacks that may occur when a remote attacker sets up a TCP connection with a very small maximum segment size (MSS). See CVE-2019-11477, CVE-2019-11478, and CVE-2019-11479 for details on these attacks. The TCP MSS Limit default is 128 bytes, which shields against most attack sizes. A value of No Limit means that there is no lower limit and any TCP MSS value is accepted.

Note: The TCP MSS Limit option only works with the following Deep Security Agent versions:

Deep Security Agent 20

Deep Security Agent 12.0 update 1 or later

Deep Security Agent 11.0 update 13 or later

Deep Security Agent 10.0 update 20 or later

- **Number of Event Nodes:** The maximum amount of kernel memory the driver will use to store log and event information for folding at any one time.

Event folding occurs when many events of the same type occur in succession. In such cases, the agent or appliance will fold all the events into one.

- **Ignore Status Code:** This option lets you ignore certain types of events. If, for example, you are getting a lot of "Invalid Flags" you can simply ignore all instances of that event.
- **Ignore Status Code:** Same as above.
- **Ignore Status Code:** Same as above.
- **Advanced Logging Policy:**
 - **Bypass:** No filtering of events. Overrides the Ignore Status Code settings and other advanced settings, but does not override logging settings defined in the Deep Security Manager. For example, if Firewall stateful configuration logging options set from a Firewall Stateful Configuration Properties window in the Deep

Security Manager will not be affected.

- **Normal:** All events are logged except dropped retransmits.
- **Default:** Will switch to Tap Mode if the engine is in tap mode, and will switch to Normal if the engine is in inline mode.
- **Backwards Compatibility Mode:** For support use only.
- **Verbose Mode:** Same as Normal but including dropped retransmits.
- **Stateful and Normalization Suppression:** Ignores dropped retransmit, out of connection, invalid flags, invalid sequence, invalid ack, unsolicited udp, unsolicited ICMP, out of allowed policy.
- **Stateful, Normalization, and Frag Suppression:** Ignores everything that **Stateful and Normalization Suppression** ignores as well as events related to fragmentation.
- **Stateful, Frag, and Verifier Suppression:** Ignores everything "**Stateful, Normalization, and Frag Suppression**" ignores as well as verifier-related events.
- **Tap Mode:** Ignores dropped retransmit, out of connection, invalid flags, invalid sequence, invalid ack, max ack retransmit, packet on closed connection.

For a more comprehensive list of which events are ignored in **Stateful and Normalization Suppression; Stateful, Normalization, and Frag Suppression; Stateful, Frag, and Verifier Suppression; and Tap** modes, see "[Reduce the number of logged events](#)" on page 1143.

- **Silent TCP Connection Drop:** When Silent TCP Connection Drop is on, a RST packet is only sent to the local stack. No RST packet is sent on the wire. This reduces the amount of information sent back to a potential attacker.

If you enable the Silent TCP Connection Drop you must also adjust the DISCONNECT Timeout. Possible values for DISCONNECT Timeout range from 0 seconds to 10 minutes. This must be set high enough that the connection is closed by the application before it is closed by the Deep Security agent or appliance. Factors that will affect the DISCONNECT Timeout value include the operating system, the applications that are creating the connections, and network topology.

- **Enable Debug Mode:** When in debug mode, the agent/appliance captures a certain number of packets (specified by the setting below: Number of Packets to retain in Debug Mode). When a rule is triggered and debug mode is on, the agent/appliance

will keep a record of the last X packets that passed before the rule was triggered. It will return those packets to the manager as debug events.

Note: Debug mode can very easily cause excessive log generation and should only be used under Client Services supervision.

- **Number of Packets to retain in Debug Mode:** The number of packets to retain and log when debug mode is on.
- **Log All Packet Data:** Record the packet data for events that are not associated with specific Firewall or Intrusion Prevention rules. That is, log packet data for events such as "Dropped Retransmit" or "Invalid ACK".

Note: Events that have been aggregated because of event folding cannot have their packet data saved.

- **Log only one packet within period:** If this option is enabled and **Log All Packet Data** is not, most logs will contain only the header data. A full packet will be attached periodically, as specified by the **Period for Log only one packet within period** setting.
- **Period for Log only one packet within period:** When **Log only one packet within period** is enabled, this setting specifies how often the log will contain full packet data.
- **Maximum data size to store when packet data is captured:** The maximum size of header or packet data to be attached to a log.
- **Generate Connection Events for TCP:** Generates a Firewall event every time a TCP connection is established.
- **Generate Connection Events for ICMP:** Generates a Firewall event every time an ICMP connection is established.
- **Generate Connection Events for UDP:** Generates a Firewall event every time a UDP connection is established.
- **Bypass CISCO WAAS Connections:** This mode bypasses stateful analysis of TCP sequence numbers for connections initiated with the proprietary CISCO WAAS TCP option selected. This protocol carries extra information in invalid TCP Sequence and ACK numbers that interfere with stateful Firewall checks. Only enable this option if you are using CISCO WAAS and you are seeing connections with Invalid SEQ or Invalid ACK in the Firewall logs. When this option is selected, TCP stateful sequence number checks are still performed for non WAAS enabled connections.

- **Drop Evasive Retransmit:** Incoming packets containing data that has already been processed will be dropped to avoid possible evasive retransmit attack techniques.
- **Verify TCP Checksum:** The segment's checksum field data will be used to assess the integrity of the segment.
- **Minimum Fragment Offset:** Defines the minimum acceptable IP fragment offset. Packets with offsets less than this will be dropped with reason "IP fragment offset too small". If set to 0 no limit is enforced. (default 60)
- **Minimum Fragment Size:** Defines the minimum acceptable IP fragment size. Fragmented packets that are smaller than this will be dropped with reason "First fragment too small" as potentially malicious. (default 120)
- **SSL Session Size:** Sets the maximum number of SSL session entries maintained for SSL session keys.
- **SSL Session Time:** Sets how long SSL session renewal keys are valid before they expire.
- **Filter IPv4 Tunnels:** Not used by this version of Deep Security.
- **Filter IPv6 Tunnels:** Not used by this version of Deep Security.
- **Strict Teredo Port Check:** Not used by this version of Deep Security.
- **Drop Teredo Anomalies:** Not used by this version of Deep Security.
- **Maximum Tunnel Depth:** Not used by this version of Deep Security.
- **Action if Maximum Tunnel Depth Exceeded:** Not used by this version of Deep Security.
- **Drop IPv6 Extension Type 0:** Not used by this version of Deep Security.
- **Drop IPv6 Fragments Lower Than minimum MTU:** Drop IPv6 fragments that do not meet the minimum MTU size specified by IETF RFC 2460.
- **Drop IPv6 Reserved Addresses:** Drop these reserved addresses:
 - IETF reserved 0000::/8
 - IETF reserved 0100::/8
 - IETF reserved 0200::/7
 - IETF reserved 0400::/6
 - IETF reserved 0800::/5
 - IETF reserved 1000::/4
 - IETF reserved 4000::/2

- IETF reserved 8000::/2
- IETF reserved C000::/3
- IETF reserved E000::/4
- IETF reserved F000::/5
- IETF reserved F800::/6

Note that the following are allowed IPv6 addresses:

- 64:ff9b::/96 - The well known prefix used in an algorithmic mapping between IPv4 and IPv6 addresses, as per RFC 6052.
- 64:ff9b:1::/48 - Prefix reserved for Local-Use IPv4/IPv6 Translation, as per RFC 8215.

For more information, see [Internet Protocol Version 6 Address Space](#).

- **Drop IPv6 Site Local Addresses:** Drop site local addresses FEC0::/10.
- **Drop IPv6 Bogon Addresses:** Drop these addresses:
 - "loopback"::1
 - "IPv4 compatible address", ::/96
 - "IPv4 mapped address" ::FFFF:0.0.0.0/96
 - "IPv4 mapped address", ::/8
 - "OSI NSAP prefix (deprecated by RFC4048)" 0200::/7
 - "6bone (deprecated)", 3ffe::/16
 - "Documentation prefix", 2001:db8::/32
- **Drop 6to4 Bogon Addresses:** Drop these addresses:
 - "6to4 IPv4 multicast", 2002:e000:: /20
 - "6to4 IPv4 loopback", 2002:7f00:: /24
 - "6to4 IPv4 default", 2002:0000:: /24
 - "6to4 IPv4 invalid", 2002:ff00:: /24
 - "6to4 IPv4 10.0.0.0/8", 2002:0a00:: /24
 - "6to4 IPv4 172.16.0.0/12", 2002:ac10:: /28
 - "6to4 IPv4 192.168.0.0/16", 2002:c0a8:: /32
- **Drop IP Packet with Zero Payload:** Drop IP packets that have a zero-length payload.

- **Drop Unknown SSL Protocol:** Drop connection if a client attempts to connect to the Deep Security Manager with the wrong protocol. By default, any protocol other than http/1.1 will cause an error.
- **Force Allow DHCP DNS:** Controls whether the following hidden Firewall rules are enabled:

Rule type	Priority	Direction	Protocol	Source port	Destination port
Force Allow	4	Outgoing	DNS	Any	53
Force Allow	4	Outgoing	DHCP	68	67
Force Allow	4	Incoming	DHCP	67	68

When the rules are enabled, agent computers can connect with the manager using the listed protocols and ports. The following values for this property are available:

- Inherited: Inherits the setting from the policy
 - Turn off rules: Disables the rules. Note that this setting can cause agent computers to appear offline
 - Allow DNS Query: Enable only the DNS-related rule
 - Allow DNS Query and DHCP Client: Enable all 3 rules
- **Force Allow ICMP type3 code4:** Controls whether the following hidden Firewall rules are enabled:

Rule type	Priority	Direction	Protocol	Type	Code
Force Allow	4	Incoming	ICMP	3	4

When enabled, these rules allow relay computers to connect with the manager so that the relay's heartbeat is transmitted. The following values are available:

- Inherited: Inherits the setting from the policy.
- Turn off rules: Disables the rule. This value can cause connection timeouts or "Destination cannot be reached" responses.
- Add Force Allow rule for ICMP type3 code4: Enables the rule.

- **Fragment Timeout:** If configured to do so, the Intrusion Prevention rules will inspect the content of a packet (or packet fragment) if that content is considered suspicious. This setting determines how long after inspecting to wait for the remaining packet fragments before discarding the packet.
- **Maximum number of fragmented IP packets to keep:** Specifies the maximum number of fragmented packets that Deep Security will keep.
- **Send ICMP to indicate fragmented packet timeout exceeded:** When this setting is enabled and the fragment timeout is exceeded, an ICMP packet is sent to the remote computer.
- **Bypass MAC addresses that don't belong to host:** Bypass incoming packets whose destination MAC address does not belong to the host. Enabling this option reduces the number of network events caused by fetching packets that are created due to NIC teaming or a NIC in promiscuous mode on agents and appliances that are version 10.2 or later.

Define rules, lists, and other common objects used by policies

About common objects

The Common Objects pages (located under **Policies > Common Objects** in Deep Security Manager) provide a way to define objects once so that you can reuse them various policies and rules. When you use one of the common objects in the policy or computer editor, its settings can be overridden for that specific policy or computer. For more information on how common object properties can be inherited and overridden at the policy or computer level, see ["Policies, inheritance, and overrides" on page 701](#).

Rules

Some protection modules make use of rules:

- ["Create a firewall rule" on page 939](#)
- [Configure an intrusion prevention rule for use in policies](#)
- ["Create an Integrity Monitoring rule" on page 985](#)
- ["Define a Log Inspection rule for use in policies" on page 1043](#)

Lists

- ["Create a list of directories for use in policies" on page 781](#)
- ["Create a list of file extensions for use in policies" on page 783](#)
- ["Create a list of files for use in policies" on page 784](#)
- ["Create a list of IP addresses for use in policies" on page 788](#)
- ["Create a list of MAC addresses for use in policies" on page 790](#)
- ["Create a list of ports for use in policies" on page 789](#)

Other

- ["Define contexts for use in policies" on page 790](#)
- ["Define stateful firewall configurations" on page 965](#)
- ["Configure malware scans and exclusions" on page 808](#)
- ["Define a schedule that you can apply to rules" on page 797](#)

Create a firewall rule

Firewall rules examine the control information in individual packets, and either block or allow them according to the criteria that you define. Firewall rules can be assigned to a policy or directly to a computer.

Note: This article specifically covers how to create a firewall rule. For information on how to configure the firewall module, see ["Set up the Deep Security firewall" on page 927](#).

To create a new firewall rule, you need to:

1. ["Add a new rule" on the next page.](#)
2. ["Select the behavior and protocol of the rule" on the next page.](#)
3. ["Select a Packet Source and Packet Destination" on page 739.](#)

When you're done with your firewall rule, you can also learn how to:

- ["Configure rule events and alerts" on page 741](#)
- ["Set a schedule for the rule" on page 741](#)
- ["See policies and computers a rule is assigned to" on page 741](#)
- ["Assign a context to the rule " on page 741](#)

Add a new rule

There are three ways to add a new firewall rule on the **Policies > Common Objects > Rules > Firewall Rules** page. You can:

- Create a new rule. Click **New > New Firewall Rule**.
- Import a rule from an XML file. Click **New > Import From File**.
- Copy and then modify an existing rule. Right-click the rule in the Firewall Rules list and then click **Duplicate**. To edit the new rule, select it and then click **Properties**.

Select the behavior and protocol of the rule

1. Enter a **Name** and **Description** for the rule.

Tip: It is good practice to document all firewall rule changes in the Description field of the firewall rule. Make a note of when and why rules were created or deleted for easier firewall maintenance.

2. Select the **Action** that the rule should perform on packets. You can select from one of the following five actions:

Note: Only one rule action is applied to a packet, and rules (of the same priority) are applied in the order of precedence listed below.

- The rule can allow traffic to **bypass** the firewall. A bypass rule allows traffic to pass through the firewall and intrusion prevention engine at the fastest possible rate. Bypass rules are meant for traffic using media intensive protocols where filtering may not be desired or for traffic originating from trusted sources.

Tip: For an example of how to create and use a bypass rule for trusted sources in a policy, see ["Allow trusted traffic to bypass the firewall" on page 945](#).

Note: Bypass rules are unidirectional. Explicit rules are required for each direction of traffic.

Tip: You can achieve maximum throughput performance on a bypass rule with the following settings:

- **Priority:** Highest
- **Frame Type:** IP
- **Protocol:** TCP, UDP, or other IP protocol. (Do not use the "Any" option.)
- **Source and Destination IP and MAC:** all "Any"
- If the protocol is TCP or UDP and the traffic direction is "incoming", the destination ports must be one or more specified ports (not "Any"), and the source ports must be "Any".
- If the protocol is TCP or UDP and the traffic direction is "outgoing", the source ports must be one or more specified ports (Not "Any"), and the destination ports must be "Any".
- **Schedule:** None.

- The rule can **log only**. This action will make entries in the logs but will not process traffic.
- The rule can **force allow** defined traffic (it will allow traffic defined by this rule without excluding any other traffic.)
- The rule can **deny** traffic (it will deny traffic defined by this rule.)
- The rule can **allow** traffic (it will exclusively allow traffic defined by this rule.)

Note: If you have no allow rules in effect on a computer, all traffic is permitted unless it is specifically blocked by a deny rule. Once you create a single allow rule, all other traffic is blocked unless it meets the requirements of the allow rule. There is one exception to this: ICMPv6 traffic is always permitted unless it is specifically blocked by a deny rule.

3. Select the **Priority** of the rule. The priority determines the order in which rules are applied. If you have selected "force allow", "deny", or "bypass" as your rule action, you can set a priority of 0 (low) to 4 (highest). Setting a priority allows you to combine the actions of rules to achieve a cascading rule effect.

Note: Log only rules can only have a priority of 4, and Allow rules can only have a priority of 0.

Note: High priority rules get applied before low priority rules. For example, a port 80 incoming deny rule with a priority of 3 will drop a packet before a port 80 incoming force allow rule with a priority of 2 gets applied to it.

For detailed information on how actions and priority work together, see "[Firewall rule actions and priorities](#)" on page 946.

4. Select a **Packet Direction**. Select whether this rule will be applied to **incoming** (from the network to the computer) or **outgoing**(from the computer to the network) traffic.

Note: An individual firewall rule only apply to a single direction of traffic. You may need to create incoming and outgoing firewall rules in pairs for specific types of traffic.

5. Select an Ethernet **Frame Type**. The term "frame" refers to Ethernet frames, and the available protocols specify the data that the frame carries. If you select "Other" as the frame type, you need to specify a [frame number](#).

6. **Note:** IP covers both IPv4 and IPv6. You can also select **IPv4** or **IPv6** individually

Note: On Solaris, Deep Security Agents will only examine packets with an IP frame type, and Linux Agents will only examine packets with IP or ARP frame types. Packets with other frame types will be allowed through. Note that the Virtual Appliance does not have these restrictions and can examine all frame types, regardless of the operating system of the virtual machine it is protecting.

If you select the Internet Protocol (IP) frame type, you need to select the transport **Protocol**. If you select "Other" as the protocol, you also need to enter a [protocol number](#).

Select a Packet Source and Packet Destination

Select a combination of **IP** and **MAC** addresses, and if available for the frame type, **Port** and **Specific Flags** for the Packet Source and Packet Destination.

Tip: You can use a previously created [IP](#), [MAC](#) or [port](#) list.

Support for IP-based frame types is as follows:

	IP	MAC	Port	Flags
Any	✓	✓		
ICMP	✓	✓		✓
ICMPV6	✓	✓		✓
IGMP	✓	✓		
GGP	✓	✓		
TCP	✓	✓	✓	✓
PUP	✓	✓		
UDP	✓	✓	✓	
IDP	✓	✓		
ND	✓	✓		
RAW	✓	✓		
TCP+UDP	✓	✓	✓	✓

Note: ARP and REVARP frame types only support using MAC addresses as packet sources and destinations.

You can select **Any Flags** or individually select the following flags:

- URG
- ACK
- PSH
- RST
- SYN
- FIN

Configure rule events and alerts

When a firewall rule is triggered, it logs an event in the Deep Security Manager and records the packet data.

Note: Note that rules using the "Allow", "Force Allow" and "Bypass" actions will not log any events.

Alerts

You can configure rules to also trigger an alert if they log an event. To do so, open the properties for a rule, click on **Options**, and then select **Alert when this rule logs an event**.

Note: Only firewall rules with an action set to "Deny" or "Log Only" can be configured to trigger an alert.

Set a schedule for the rule

Select whether the firewall rule should only be active during a scheduled time.

For more information on how to do so, see ["Define a schedule that you can apply to rules" on page 797](#).

Assign a context to the rule

Rule contexts allow you to set firewall rules uniquely for different network environments. Contexts are commonly used to allow for different rules to be in effect for laptops when they are on and off-site.

For more information on how to create a context, see ["Define contexts for use in policies" on page 790](#).

Tip: For an example of a policy that implements firewall rules using contexts, look at the properties of the "Windows Mobile Laptop" Policy.

See policies and computers a rule is assigned to

You can see which policies and computers are assigned to a firewall rule on the **Assigned To** tab. Click on a policy or computer in the list to see their properties.

Export a rule

You can export all firewall rules to a .csv or .xml file by clicking **Export** and selecting the corresponding export action from the list. You can also export specific rules by first selecting them, clicking **Export** and then selecting the corresponding export action from the list.

Delete a rule

To delete a rule, right-click the rule in the Firewall Rules list, click **Delete** and then click **OK**.

Note: Firewall Rules that are assigned to one or more computers or that are part of a policy cannot be deleted.

Configure intrusion prevention rules

Perform the following tasks to configure and work with intrusion prevention rules:

- ["See the list of intrusion prevention rules" on the next page](#)
- ["See information about an intrusion prevention rule" on the next page](#)
- ["See information about the associated vulnerability \(Trend Micro rules only\)" on page 745](#)
- ["Assign and unassign rules" on page 745](#)
- ["Automatically assign updated required rules" on page 746](#)
- ["Configure event logging for rules" on page 746](#)
- ["Generate alerts" on page 747](#)
- ["Setting configuration options \(Trend Micro rules only\)" on page 747](#)
- ["Schedule active times" on page 748](#)
- ["Exclude from recommendations" on page 749](#)
- ["Set the context for a rule" on page 749](#)
- ["Override the behavior mode for a rule" on page 749](#)
- ["Override rule and application type configurations" on page 750](#)
- ["Export and import rules" on page 751](#)
- ["Configure an SQL injection prevention rule" on page 897](#)

For an overview of the intrusion prevention module, see ["About Intrusion Prevention" on page 878](#).

See the list of intrusion prevention rules

The Policies page provides a list of intrusion prevention rules. You can search for intrusion prevention rules, and open and edit rule properties. In the list, rules are grouped by application type, and some rule properties appear in different columns.

Tip: The "TippingPoint" column contains the equivalent Trend Micro TippingPoint rule ID. In the Advanced Search for intrusion prevention, you can search on the TippingPoint rule ID. You can also see the TippingPoint rule ID in the list of assigned intrusion prevention rules in the policy and computer editor.

To see the list, click **Policies**, and then below **Common Objects/Rules** click **Intrusion Prevention Rules**.

See information about an intrusion prevention rule



The properties of intrusion prevention rules include information about the rule and the exploit against which it protects.

1. Click **Policies > Intrusion Prevention Rules**.
2. Select a rule and click **Properties**.

General Information

- **Name:** The name of the intrusion prevention rule.
- **Description:** The description of the intrusion prevention rule.
- **Minimum Agent/Appliance Version:** The minimum version of the Deep Security **Agent or Appliance**¹ required to support this intrusion prevention rule.

Details

Clicking **New** () or **Properties** () displays the **Intrusion Prevention Rule Properties** window.

¹The Deep Security Agent and Deep Security Virtual Appliance are the components that enforce the Deep Security policies that you have defined. Agents are deployed directly on a computer. Appliances are used in VMware vSphere environments to provide agentless protection. They are not available with Deep Security as a Service.

Note: Note the **Configuration** tab. Intrusion Prevention Rules from Trend Micro are not directly editable through Deep Security Manager. Instead, if the Intrusion Prevention Rule requires (or allows) configuration, those configuration options will be available on the **Configuration** tab. Custom Intrusion Prevention Rules that you write yourself will be editable, in which case the **Rules** tab will be visible.

See the list of intrusion prevention rules

The Policies page provides a list of intrusion prevention rules. You can search for intrusion prevention rules, and open and edit rule properties. In the list, rules are grouped by application type, and some rule properties appear in different columns.

Tip: The "TippingPoint" column contains the equivalent Trend Micro TippingPoint rule ID. In the Advanced Search for intrusion prevention, you can search on the TippingPoint rule ID. You can also see the TippingPoint rule ID in the list of assigned intrusion prevention rules in the policy and computer editor.

To see the list, click **Policies**, and then below **Common Objects/Rules** click **Intrusion Prevention Rules**.

General Information

- **Application Type:** The application type under which this intrusion prevention rule is grouped.

Tip: You can edit application types from this panel. When you edit an application type from here, the changes are applied to all security elements that use it.

- **Priority:** The priority level of the rule. Higher priority rules are applied before lower priority rules.
- **Severity:** Setting the severity of a rule has no effect on how the rule is implemented or applied. Severity levels can be useful as sorting criteria when viewing a list of intrusion prevention rules. More importantly, each severity level is associated with a severity value; this value is multiplied by a computer's Asset Value to determine the Ranking of an Event. (See **Administration > System Settings > Ranking**.)
- **CVSS Score:** A measure of the severity of the vulnerability according the [National Vulnerability Database](#).

Identification (Trend Micro rules only)

- **Type:** Can be either Smart (one or more known and unknown (zero day) vulnerabilities), Exploit (a specific exploit, usually signature based), or Vulnerability (a specific vulnerability for which one or more exploits may exist).
- **Issued:** The date the rule was released. This does not indicate when the rule was downloaded.
- **Last Updated:** The last time the rule was modified either locally or during Security Update download.
- **Identifier:** The rule's unique identification tag.

See information about the associated vulnerability (Trend Micro rules only)

Rules that Trend Micro provides can include information about the vulnerability against which the rule protects. When applicable, the Common Vulnerability Scoring System (CVSS) is displayed. (For information on this scoring system, see the CVSS page at the [National Vulnerability Database](#).)

1. Click **Policies > Intrusion Prevention Rules**.
2. Select a rule and click **Properties**.
3. Click the **Vulnerabilities** tab.

Assign and unassign rules

To apply intrusion prevention rules during agent scans, you assign them to the appropriate policies and computers. When the rule is no longer necessary because the vulnerability has been patched you can unassign the rule.

If you cannot unassign intrusion prevention rules from a **Computer editor**¹, it is likely because the rules are currently assigned in a policy. Rules assigned at the policy level must be removed using the **Policy editor**² and cannot be removed at the computer level.

When you make a change to a policy, it affects all computers using the policy. For example, when you unassign a rule from a policy you remove the rule from all computers that are protected by that policy. To continue to apply the rule to other computers, create a new policy for that group of computers. (See "[Policies, inheritance, and overrides](#)" on page 701.)

¹To open the Computer editor, go to the Computers page and double-click the computer that you want to edit (or select the computer and click Details).

²To open the Policy editor, go to the Policies page and double-click the policy that you want to edit (or select the policy and click Details).

Tip: To see the policies and computers to which a rule is assigned, see the Assigned To tab of the rule properties.

1. Go to the **Policies** page, right-click the policy to configure and click **Details**.
2. Click **Intrusion Prevention > General**.
The list of rules that are assigned to the policy appear in the **Assigned Intrusion Prevention Rules** list.
3. Under **Assigned Intrusion Prevention Rules**, click **Assign/Unassign**.
4. To assign a rule, select the check box next to the rule.
5. To unassign a rule, deselect the check box next to the rule.
6. Click **OK**.

Automatically assign updated required rules

Security updates can include new or updated application types and intrusion prevention rules which require the assignment of secondary intrusion prevention rules. Deep Security can automatically assign these rules if they are required. You enable these automatic assignments in the the policy or computer properties.

1. Go to the **Policies** page, right-click the policy to configure and click **Details**.
2. Click **Intrusion Prevention > Advanced**.
3. To enable the automatic assignments, in the **Rule Updates** area, select **Yes**.
4. Click **OK**.

Configure event logging for rules

Configure whether events are logged for a rule, and whether to include packet data in the log.

Note: Deep Security can display X-Forwarded-For headers in intrusion prevention events when they are available in the packet data. This information can be useful when the Deep Security Agent is behind a load balancer or proxy. The X-Forwarded-For header data appears in the event's Properties window. To include the header data, include packet data in the log. In addition, rule 1006540 " Enable X-Forwarded-For HTTP Header Logging" must be assigned.

Because it would be impractical to record all packet data every time a rule triggers an event, Deep Security records the data only the first time the event occurs within a specified period of time. The default time is five minutes, however you can change the time period using the "Period for Log only one packet within period" property of a policy's Advanced Network Engine settings. (See [Advanced Network Engine Options](#).)

The configuration performed in the following procedure affects all policies. For information about configuring a rule for one policy, see ["Override rule and application type configurations" on page 750](#).

1. Click **Policies > Intrusion Prevention Rules**.
2. Select a rule and click **Properties**.
3. On the General tab, go to the Events area and select the desired options:
 - To disable logging for the rule, select **Disable Event Logging**.
 - To log an event when a packet is dropped or blocked, select **Generate Event on Packet Drop**.
 - To include the packet data in the log entry, select **Always Include Packet Data**.
 - To log several packets that precede and follow the packet that the rule detected, select **Enable Debug Mode**. Use debug mode only when your support provider instructs you to do so.

Additionally, to include packet data in the log, the policy to which the rule is assigned must allow rules to capture packet data:

1. On the Policies page, open the policy that is assigned the rule.
2. Click **Intrusion Prevention > Advanced**.
3. In the **Event Data** area, select **Yes**.

Generate alerts

Generate an alert when an intrusion prevention rule triggers an event.

The configuration performed in the following procedure affects all policies. For information about configuring a rule for one policy, see ["Override rule and application type configurations" on page 750](#).

1. Click **Policies > Intrusion Prevention Rules**.
2. Select a rule and click **Properties**.
3. Click the Options tab, and in the **Alert** area select **On**.
4. Click **OK**.

Setting configuration options (Trend Micro rules only)

Some intrusion prevention rules that Trend Micro provides have one or more configuration options such as header length, allowed extensions for HTTP, or cookie length. Some options require you to configure them. If you assign a rule without setting a required option, an alert is

generated that informs you about the required option. (This also applies to any rules that are downloaded and automatically applied by way of a Security Update.)

Intrusion prevention rules that have configuration options appear in the Intrusion Prevention Rules list with a small gear over their icon .

Note: Custom intrusion prevention rules that you write yourself include a **Rules** tab where you can edit the rules.

The configuration performed in the following procedure affects all policies. For information about configuring a rule for one policy, see ["Override rule and application type configurations" on page 750](#).

1. Click **Policies > Intrusion Prevention Rules**.
2. Select a rule and click **Properties**.
3. Click the **Configuration** tab.
4. Configure the properties and then click **OK**.

Schedule active times

Schedule a time during which an intrusion prevention rule is active. Intrusion prevention rules that are active only at scheduled times appear in the Intrusion Prevention Rules page with a small clock over their icon .

Note: With Agent-based protection, schedules use the same time zone as the endpoint operating system. With Agentless protection, schedules use the same time zone as the Deep Security Virtual Appliance.

The configuration performed in the following procedure affects all policies. For information about configuring a rule for one policy, see ["Override rule and application type configurations" on page 750](#).

1. Click **Policies > Intrusion Prevention Rules**.
2. Select a rule and click **Properties**.
3. Click the **Options** tab.
4. In the **Schedule** area, select **New** or select a frequency.
5. Edit the schedule as required.
6. Click **OK**.

Exclude from recommendations

Exclude intrusion prevention rules from rule recommendations of recommendation scans.

The configuration performed in the following procedure affects all policies. For information about configuring a rule for one policy, see ["Override rule and application type configurations" on the next page](#).

1. Click **Policies > Intrusion Prevention Rules**.
2. Select a rule and click **Properties**.
3. Click the **Options** tab.
4. In the **Recommendations Options** area, select **Exclude from Recommendations**.
5. Click **OK**.

Set the context for a rule

Set the context in which the rule is applied.

The configuration performed in the following procedure affects all policies. For information about configuring a rule for one policy, see ["Override rule and application type configurations" on the next page](#).

1. Click **Policies > Intrusion Prevention Rules**.
2. Select a rule and click **Properties**.
3. Click the **Options** tab.
4. In the **Context** area, select **New** or select a context.
5. Edit the context as required.
6. Click **OK**.

Override the behavior mode for a rule

Set the behavior mode of an intrusion prevention rule to Detect when testing new rules. In Detect mode, the rule creates a log entry prefaced with the words "detect only:" and does not interfere with traffic. Some intrusion prevention rules are designed to operate only in Detect mode. For these rules, you cannot change the behavior mode.

Note: If you disable logging for the rule, the rule activity is not logged regardless of the behavior mode.

For more information about behavior modes, see ["Use behavior modes to test rules" on page 879](#).

The configuration performed in the following procedure affects all policies. For information about configuring a rule for one policy, see "[Override rule and application type configurations](#)" below.

1. Click **Policies > Intrusion Prevention Rules**.
2. Select a rule and click **Properties**.
3. Select **Detect Only**.

Override rule and application type configurations

From a **Computer or Policy editor**¹, you can edit an intrusion prevention rule so that your changes apply only in the context of the policy or computer. You can also edit the rule so that the changes apply globally so that the changes affect other policies and computers that are assigned the rule. Similarly, you can configure application types for a single policy or computer, or globally.

1. Go to the **Policies** page, right-click the policy to configure and click **Details**.
2. Click **Intrusion Prevention**.
3. To edit a rule, right-click the rule and select one of the following commands:
 - **Properties**: Edit the rule only for the policy.
 - **Properties (Global)**: Edit the rule globally, for all policies and computers.
4. To edit the application type of a rule, right-click the rule and select one of the following commands:
 - **Application Type Properties**: Edit the application type only for the policy.
 - **Application Type Properties (Global)**: Edit the application type globally, for all policies and computers.
5. Click **OK**.

Tip: When you select the rule and click **Properties**, you are editing the rule only for the policy that you are editing.

Note: You cannot assign one port to more than eight application types. If they are, the rules will not function on that port.

¹You can change these settings for a policy or for a specific computer. To change the settings for a policy, go to the **Policies** page and double-click the policy that you want to edit (or select the policy and click **Details**). To change the settings for a computer, go to the **Computers** page and double-click the computer that you want to edit (or select the computer and click **Details**).

Export and import rules

You can export one or more intrusion prevention rules to an XML or CSV file, and import rules from an XML file.

1. Click **Policies > Intrusion Prevention Rules**.
2. To export one or more rules, select them and click **Export > Export Selected to CSV** or **Export > Export Selected to XML**.
3. To export all rules, click **Export > Export to CSV** or **Export > Export to XML**.
4. To import rules, click **New > Import From File** and follow the instructions on the wizard.

Create an Integrity Monitoring rule

Integrity Monitoring rules describe how Deep Security Agents should scan for and detect changes to a computer's files, directories, and registry keys and values, as well as changes in installed software, processes, listening ports, and running services. Integrity Monitoring rules can be assigned directly to computers or can be made part of a policy.

Note: This article specifically covers how to create an Integrity Monitoring rule. For information on how to configure the Integrity Monitoring module, see ["Set up Integrity Monitoring" on page 977](#).

There are two types of Integrity Monitoring rules: those that you have created, and those that are issued by Trend Micro. For more information on how to configure rules issued by Trend Micro, see the ["Configure Trend Micro Integrity Monitoring rules" on page 753](#) section.

To create a new Integrity Monitoring rule, you need to:

1. ["Add a new rule" on the next page](#).
2. ["Enter Integrity Monitoring rule information " on the next page](#).
3. ["Select a rule template and define rule attributes" on the next page](#).

When you're done with your rule, you can also learn how to

- ["Configure rule events and alerts" on page 754](#)
- ["See policies and computers a rule is assigned to" on page 755](#)
- ["Export a rule" on page 755](#)
- ["Delete a rule" on page 755](#)

Add a new rule

There are three ways to add an Integrity Monitoring rule on the **Policies > Common Objects > Rules > Integrity Monitoring Rules** page. You can:

- Create a new rule. Click **New > New Integrity Monitoring Rule**.
- Import a rule from an XML file. Click **New > Import From File**.
- Copy and then modify an existing rule. Right-click the rule in the Integrity Monitoring Rules list and then click **Duplicate**. To edit the new rule, select it and then click **Properties**.

Enter Integrity Monitoring rule information

1. Enter a **Name** and **Description** for the rule.

Tip: It is good practice to document all Integrity Monitoring rule changes in the Description field of the rule. Make a note of when and why rules were created or deleted for easier maintenance.

2. Set the **Severity** of the rule.

Note: Setting the severity of a rule has no effect on how the rule is implemented or applied. Severity levels can be useful as sorting criteria when viewing a list of Integrity Monitoring rules. More importantly, each severity level is associated with a severity value; this value is multiplied by a computer's Asset Value to determine the ranking of an event. (See **Administration > System Settings > Ranking**.)

Select a rule template and define rule attributes

Go to the **Content** tab and select from one of the following three templates:

Registry Value template

Create an Integrity Monitoring rule to specifically monitor changes to registry values.

Note: The Registry Value template is only for Windows-based computers .

1. Select the **Base Key** to monitor and whether or not to monitor contents of sub keys.
2. List **Value Names** to be included or excluded. You can use "?" and "*" as wildcard characters.

3. Enter **Attributes** to monitor. Entering "STANDARD" will monitor changes in registry size, content and type. For more information on Registry Value template attributes see the ["RegistryValueSet" on page 1021](#) documentation.

File template

Create an Integrity Monitoring rule to specifically monitor changes to files.

1. Enter a **Base Directory** for the rule (for example, `C:\Program Files\MySQL` .) Select **Include Sub Directories** to include the contents of all subdirectories relative to the base directory. Wildcards are not supported for base directories.
2. Use the **File Names** fields to include or exclude specific files. You can use wildcards (" ? " for a single character and " * " for zero or more characters).

Note: Leaving the **File Names** fields blank will cause the rule to monitor all files in the base directory. This can use significant system resources if the base directory contains numerous or large files.

3. Enter **Attributes** to monitor. Entering "STANDARD" will monitor changes in file creation date, last modified date, permissions, owner, group, size, content, flags (Windows), and SymLinkPath (Linux). For more information on File template attributes see the ["FileSet" on page 1005](#) documentation.

Custom (XML) template

Create a custom Integrity Monitoring rule template to monitor [directories](#), [registry values](#), [registry keys](#), [services](#), [processes](#), [installed software](#), [ports](#), [groups](#), [users](#), [files](#), and the [WQL](#) using the Deep Security XML-based ["About the Integrity Monitoring rules language" on page 989](#).





Tip: You can create your rule in your preferred text editor and paste it to the **Content** field when you are done.

Configure Trend Micro Integrity Monitoring rules

Integrity Monitoring rules issued by Trend Micro cannot be edited in the same way as the custom rules you create. Some Trend Micro rules cannot be modified at all, while other rules may offer limited configuration options. Both of these rule types will show as "Defined" under the "Type" column, but rules that can be configured will display a gear in the Integrity Monitoring icon ().

Integrity Monitoring Rules No Grouping ▾ 🔍 Search this page

New ▾
Delete...
Properties...
Duplicate
Export ▾

NAME	SEVERITY	TYPE	LAST UPDATED ▲
 New Integrity Monitoring Rule	● Medium	Custom	N/A
 1002784 - Microsoft Windows - IE A...	● Medium	Defined	June 23, 2009
 1002781 - Microsoft Windows - Attr...	● Medium	Defined	June 23, 2009
 1002778 - Microsoft Windows - Syst...	● High	Defined	June 23, 2009

You can access the configuration options for a rule by opening the properties for the rule and clicking on the **Configuration** tab.

Rules issued by Trend Micro also show the following additional information under the **General** tab:

- When the rule was first issued and last updated, as well as a unique identifier for the rule.
- The minimum versions of the Agent and the Deep Security Manager that are required for the rule to function.

Although you cannot edit rules issued by Trend Micro directly, you can duplicate them and then edit the copy.

Configure rule events and alerts

Any changes detected by an Integrity Monitoring rule is logged as an event in the Deep Security Manager.

Real-time event monitoring

By default, events are logged at the time they occur. If you only want events to be logged when you manually perform a scan for changes, deselect **Allow Real Time Monitoring**.

Alerts

You can also configure the rules to trigger an alert when they log an event. To do so, open the properties for a rule, click on **Options**, and then select **Alert when this rule logs an event**.

See policies and computers a rule is assigned to

You can see which policies and computers are assigned to an Integrity Monitoring rule on the **Assigned To** tab. Click on a policy or computer in the list to see their properties.

Export a rule

You can export all Integrity Monitoring rules to a .csv or .xml file by clicking **Export** and selecting the corresponding export action from the list. You can also export specific rules by first selecting them, clicking **Export** and then selecting the corresponding export action from the list.

Delete a rule

To delete a rule, right-click the rule in the Integrity Monitoring Rules list, click **Delete** and then click **OK**.

Note: Integrity Monitoring rules that are assigned to one or more computers or that are part of a policy cannot be deleted.

Define a Log Inspection rule for use in policies

The OSSEC Log Inspection engine is integrated into Deep Security Agents and gives Deep Security the ability to inspect the logs and events generated by the operating system and applications running on the computer. Deep Security Manager ships with a standard set of OSSEC Log Inspection rules that you can assign to computers or policies. You can also create custom rules if there is no existing rule that fits your requirements.

Log Inspection Rules issued by Trend Micro are not editable (although you can duplicate them and then edit them.)

Note: Log Inspection Rules that are assigned to one or more computers or that are part of a policy cannot be deleted.

To create Log Inspection rules, perform these basic steps:

- ["Create a new Log Inspection rule" on the next page](#)
- ["Decoders" on page 758](#)
- ["Subrules" on page 759](#)

- ["Real world examples" on page 767](#)
- ["Log Inspection rule severity levels and their recommended use" on page 775](#)
- ["strftime\(\) conversion specifiers " on page 776](#)
- ["Examine a Log Inspection rule" on page 777](#)

For an overview of the Log Inspection module, see ["About Log Inspection" on page 1038](#).

Create a new Log Inspection rule

1. In the Deep Security Manager, go to **Policies > Common Objects > Rules > Log Inspection Rules**.
2. Click **New > New Log Inspection Rule**.
3. On the **General** tab, enter a name and an optional description for the rule.
4. The **Content** tab is where you define the rule. The easiest way to define a rule is to select **Basic Rule** and use the options provided to define the rule. If you need further customization, you can select **Custom (XML)** to switch to an XML view of the rule that you are defining.

Note: Any changes you make in the Custom (XML) view will be lost if you switch back to the Basic Rule view.

For further assistance in writing your own Log Inspection rules using the XML-based language, consult the [OSSEC](#) documentation or contact your support provider.

These options are available for the Basic Rule template:

- **Rule ID:** The Rule ID is a unique identifier for the rule. OSSEC defines 100000 - 109999 as the space for user-defined rules. Deep Security Manager will pre-populate the field with a new unique Rule ID.
- **Level:** Assign a level to the rule. Zero (0) means the rule never logs an event, although other rules that watch for this rule may fire.
- **Groups:** Assign the rule to one or more comma-separated groups. This can be useful when dependency is used because you can create rules that fire on the firing of a rule, or a rule that belongs to a specific group.
- **Rule Description:** Description of the rule.
- **Pattern Matching:** This is the pattern the rule will look for in the logs. The rule will be

triggered on a match. Pattern matching supports Regular Expressions or simpler String Patterns. The "String Pattern" pattern type is faster than RegEx but it only supports three special operations:

- **^ (caret)**: specifies the beginning of text
- **\$ (dollar sign)**: specifies the end of text
- **| (pipe)**: to create a "OR" between multiple patterns

For information on the regular expression syntax used by the Log Inspection module, see <https://www.ossec.net/docs/syntax/regex.html>.

- **Dependency**: Setting a dependency on another rule will cause your rule to only log an event if the rule specified in this area has also triggered.
- **Frequency** is the number of times the rule has to match within a specific time frame before the rule is triggered.
- **Time Frame** is the period of time in seconds within which the rule has to trigger a certain number of times (the frequency, above) to log an event.

Note: The **Content** tab only appears for Log Inspection rules that you create yourself. Log Inspection rules issued by Trend Micro have a **Configuration** tab instead that displays the Log Inspection rule's configuration options (if any).

5. On the **Files** tab, type the full path to the files you want your rule to monitor and specify the type of file it is. Note that the path and file name do not support the glob character.
6. On the **Options** tab, in the **Alert** section, select whether this rule triggers an alert in the Deep Security Manager.

Alert Minimum Severity sets the minimum severity level that will trigger an Alert for rules made using the Basic Rule or Custom (XML) template.

Note: The Basic Rule template creates one rule at a time. To write multiple rules in a single template you can use the Custom (XML) template. If you create multiple rules with different Levels within a Custom (XML) template, you can use the **Alert Minimum Severity** setting to select the minimum severity that will trigger an Alert for all of the rules in that template.

7. The **Assigned To** tab lists the policies and computers that are using this Log Inspection rule. Because you are creating a new rule, it has not been assigned yet.

8. Click **OK**. The rule is ready to be assigned to policies and computers.

Decoders

A Log Inspection rule consists of a list of files to monitor for changes and a set of conditions to be met for the rule to trigger. When the Log Inspection engine detects a change in a monitored log file, the change is parsed by a decoder. Decoders parse the raw log entry into the following fields:

- **log**: the message section of the event
- **full_log**: the entire event
- **location**: where the log came from
- **hostname**: hostname of the event source
- **program_name**: program name from the syslog header of the event
- **srcip**: the source IP address within the event
- **dstip**: the destination IP address within the event
- **srcport**: the source port number within the event
- **dstport**: the destination port number within the event
- **protocol**: the protocol within the event
- **action**: the action taken within the event
- **srcuser**: the originating user within the event
- **dstuser**: the destination user within the event
- **id**: any ID decoded as the ID from the event
- **status**: the decoded status within the event
- **command**: the command being called within the event
- **url**: the URL within the event
- **data**: any additional data extracted from the event
- **systemname**: the system name within the event

Rules examine this decoded data looking for information that matches the conditions defined in the rule.

If the matches are at a sufficiently high severity level, any of the following actions can be taken:

- An alert can be raised. (Configurable on the **Options** tab of the Log Inspection Rule's **Properties** window.)

- The event can be written to syslog. (Configurable in the **SIEM** area on **Administration > System Settings > Event Forwarding** tab.)
- The event can be sent to the Deep Security Manager. (Configurable in the **Log Inspection Syslog Configuration** setting on the **Policy or Computer Editor > Settings > Event Forwarding** tab.)

Subrules

A single Log Inspection rule can contain multiple subrules. These subrules can be of two types: atomic or composite. An atomic rule evaluates a single event and a composite rule examines multiple events and can evaluate frequency, repetition, and correlation between events.

Groups

Each rule, or grouping of rules, must be defined within a `<group></group>` element. The attribute name must contain the rules you want to be a part of this group. In the following example we have indicated that our group contains the syslog and sshd rules:

```
<group name="syslog,sshd,">  
</group>
```

Note: Notice the trailing comma in the group name. Trailing commas are required if you intend to use the `<if_group></if_group>` tag to conditionally append another sub-rule to this one.

Note: When a set of Log Inspection rules are sent to an agent, the Log Inspection engine on the agent takes the XML data from each assigned rule and assembles it into what becomes essentially a single long Log Inspection rule. Some group definitions are common to all Log Inspection rules written by Trend Micro. For this reason Trend Micro has included a rule called "Default Rules Configuration" which defines these groups and which always gets assigned along with any other Trend Micro rules. (If you select a rule for assignment and haven't also selected the "Default Rules Configuration" rule, a notice will appear informing you that the rule will be assigned automatically.) *If you create your own Log Inspection rule and assign it to a Computer without assigning any Trend Micro-written rules, you must either copy the content of the "Default Rules Configuration" rule into your new rule, or also select the "Default Rules Configuration" rule for assignment to the Computer.*

Rules, ID, and Level

A group can contain as many rules as you require. The rules are defined using the `<rule></rule>` element and must have at least two attributes, the `id` and the `level`. The `id` is a unique identifier for that signature and the `level` is the severity of the alert. In the following example, we have created two rules, each with a different rule ID and level:

```
<group name="syslog,sshd,">
  <rule id="100120" level="5">
  </rule>
  <rule id="100121" level="6">
  </rule>
</group>
```

Note: Custom rules must have ID values of 100,000 or greater.

You can define additional subgroups within the parent group using the `<group></group>` tag. This subgroup can reference any of the groups listed in the following table:

Group Type	Group Name	Description
Reconnaissance	connection_attempt web_scan recon	Connection attempt Web scan Generic scan
Authentication Control	authentication_success authentication_failed invalid_login login_denied authentication_failures adduser account_changed	Success Failure Invalid Login Denied Multiple Failures User account added User Account changed or removed
Attack/Misuse	automatic_attack exploit_attempt invalid_access spam multiple_spam sql_injection attack virus	Worm (nontargeted attack) Exploit pattern Invalid access Spam Multiple spam messages SQL injection Generic attack Virus detected
Access Control	access_denied access_allowed unknown_resource firewall_drop multiple_drops client_misconfig client_error	Access denied Access allowed Access to nonexistent resource Firewall drop Multiple firewall drops Client misconfiguration Client error

Group Type	Group Name	Description
Network Control	new_host ip_spoof	New computer detected Possible ARP spoofing
System Monitor	service_start system_error system_shutdown logs_cleared invalid_request promisc policy_changed config_changed low_diskspace time_changed	Service start System error Shutdown Logs cleared Invalid request Interface switched to promiscuous mode Policy changed Configuration changed Low disk space Time changed

Note: If event auto-tagging is enabled, the event will be labeled with the group name. Log Inspection rules provided by Trend Micro make use of a translation table that changes the group to a more user-friendly version. So, for example, "login_denied" would appear as "Login Denied". Custom rules will be listed by their group name as it appears in the rule.

Description

Include a `<description></description>` tag. The description text will appear in the event if the rule is triggered.

```
<group name="syslog,sshd,">
  <rule id="100120" level="5">
    <group>authentication_success</group>
    <description>SSHD testing authentication success</description>
  </rule>
  <rule id="100121" level="6">
    <description>SSHD rule testing 2</description>
  </rule>
</group>
```

Decoded As

The `<decoded_as></decoded_as>` tag instructs the Log Inspection engine to only apply the rule if the specified decoder has decoded the log.

```
<rule id="100123" level="5">
  <decoded_as>sshd</decoded_as>
  <description>Logging every decoded sshd message</description>
</rule>
```

Note: To view the available decoders, go to the **Log Inspection Rule** page and click **Decoders**. Right-click on **1002791-Default Log Decoders** and select **Properties**. Go the **Configuration** tab and click **View Decoders**.

Match

To look for a specific string in a log, use the `<match></match>`. Here is a Linux sshd failed password log:

```
Jan 1 12:34:56 linux_server sshd[1231]: Failed password for invalid
user jsmith from 192.168.1.123 port 1799 ssh2
```

Use the `<match></match>` tag to search for the "password failed" string.

```
<rule id="100124" level="5">
  <decoded_as>sshd</decoded_as>
  <match>^Failed password</match>
  <description>Failed SSHD password attempt</description>
</rule>
```

Note: Notice the regex caret ("^") indicating the beginning of a string. Although "Failed password" does not appear at the beginning of the log, the Log Inspection decoder will have broken up the log into sections. See ["Decoders" on page 758](#) for more information. One of those sections is "log" which is the message part of the log as opposed to "full_log" which is the log in its entirety.

The following table lists supported regex syntax:

Regex Syntax	Description
\w	A-Z, a-z, 0-9 single letters and numerals
\d	0-9 single numerals
\s	single space
\t	single tab
\p	()*+,-.::;<=>?[]
\W	not \w
\D	not \d
\S	not \s
\.	anything
+	match one or more of any of the above (for example, \w+, \d+)
*	match zero or more of any of the above (for example, \w*, \d*)
^	indicates the beginning of a string (^somestring)

Regex Syntax	Description
\$	specify the end of a string (somestring\$)
	indicate an "OR" between multiple strings

Conditional Statements

Rule evaluation can be conditional upon other rules having been evaluated as true. The `<if_sid></if_sid>` tag instructs the Log Inspection engine to only evaluate this subrule if the rule identified in the tag has been evaluated as true. The following example shows three rules: 100123, 100124, and 100125. Rules 100124 and 100125 have been modified to be children of the 100123 rule using the `<if_sid></if_sid>` tag:

```
<group name="syslog,sshd,">
  <rule id="100123" level="2">
    <decoded_as>sshd</decoded_as>
    <description>Logging every decoded sshd message</description>
  </rule>
  <rule id="100124" level="7">
    <if_sid>100123</if_sid>
    <match>^Failed password</match>
    <group>authentication_failure</group>
    <description>Failed SSHD password attempt</description>
  </rule>
  <rule id="100125" level="3">
    <if_sid>100123</if_sid>
    <match>^Accepted password</match>
    <group>authentication_success</group>
    <description>Successful SSHD password attempt</description>
  </rule>
</group>
```

Hierarchy of Evaluation

The `<if_sid></if_sid>` tag essentially creates a hierarchical set of rules. That is, by including an `<if_sid></if_sid>` tag in a rule, the rule becomes a child of the rule referenced by the `<if_sid></if_sid>` tag. Before applying any rules to a log, the Log Inspection engine assesses the `<if_sid></if_sid>` tags and builds a hierarchy of parent and child rules.

Note: The hierarchical parent-child structure can be used to improve the efficiency of your rules. If a parent rule does not evaluate as true, the Log Inspection engine will ignore the children of that parent.

Note: Although the `<if_sid></if_sid>` tag can be used to refer to subrules within an entirely different Log Inspection rule, you should avoid doing this because it makes the rule very difficult to review later on.

The list of available atomic rule conditional options is shown in the following table:

Tag	Description	Notes
match	A pattern	Any string to match against the event (log).
regex	A regular expression	Any regular expression to match against the event(log).
decoded_as	A string	Any prematched string.
srcip	A source IP address	Any IP address that is decoded as the source IP address. Use "!" to negate the IP address.
dstip	A destination IP address	Any IP address that is decoded as the destination IP address. Use "!" to negate the IP address.
srcport	A source port number	Any source port (match format).
dstport	A destination port number	Any destination port (match format).
user	A username	Any username that is decoded as a username.
program_name	A program name	Any program name that is decoded from the syslog process name.
hostname	A system hostname	Any hostname that is decoded as a syslog hostname.
time	A time range in the format hh:mm - hh:mm or hh:mm am - hh:mm pm	The time range that the event must fall within for the rule to trigger.
weekday	A weekday (sunday, monday, tuesday, etc.)	Day of the week that the event must fall on for the rule to trigger.
id	An ID	Any ID that is decoded from the event.
url	A URL	Any URL that is decoded from the event.

Use the `<if_sid>100125</if_sid>` tag to make this rule depend on the 100125 rule. This rule will be checked only for sshd messages that already matched the successful login rule.

```
<rule id="100127" level="10">
  <if_sid>100125</if_sid>
  <time>6 pm - 8:30 am</time>
  <description>Login outside business hours.</description>
  <group>policy_violation</group>
</rule>
```

Restrictions on the Size of the Log Entry

The following example takes the previous example and adds the **maxsize** attribute which tells the Log Inspection engine to only evaluate rules that are less than the maxsize number of

characters:

```
<rule id="100127" level="10" maxsize="2000">
  <if_sid>100125</if_sid>
  <time>6 pm - 8:30 am</time>
  <description>Login outside business hours.</description>
  <group>policy_violation</group>
</rule>
```

The following table lists possible atomic rule tree-based options:

Tag	Description	Notes
if_sid	A rule ID	Adds this rule as a child rule of the rules that match the specified signature ID.
if_group	A group ID	Adds this rule as a child rule of the rules that match the specified group.
if_level	A rule level	Adds this rule as a child rule of the rules that match the specified severity level.
description	A string	A description of the rule.
info	A string	Extra information about the rule.
cve	A CVE number	Any Common Vulnerabilities and Exposures (CVE) number that you would like associated with the rule.
options	alert_by_email no_email_alert no_log	Additional rule options to indicate if the Alert should generate an e-mail, alert_by_email, should not generate an email, no_email_alert, or should not log anything at all, no_log.

Composite Rules

Atomic rules examine single log entries. To correlate multiple entries, you must use composite rules. Composite rules are supposed to match the current log with those already received. Composite rules require two additional options: the **frequency** option specifies how many times an event or pattern must occur before the rule generates an alert, and the **timeframe** option tells the Log Inspection engine how far back, in seconds, it should look for previous logs. All composite rules have the following structure:

```
<rule id="100130" level="10" frequency="x" timeframe="y">
</rule>
```

For example, you could create a composite rule that creates a higher severity alert after five failed passwords within a period of 10 minutes. Using the `<if_matched_sid></if_matched_sid>` tag you can indicate which rule needs to be seen within the desired frequency and timeframe for your new rule to create an alert. In the following example, the **frequency** attribute is set to trigger

when five instances of the event are seen and the **timeframe** attribute is set to specify the time window as 600 seconds.

The `<if_matched_sid></if_matched_sid>` tag is used to define which other rule the composite rule will watch:

```
<rule id="100130" level="10" frequency="5" timeframe="600">
  <if_matched_sid>100124</if_matched_sid>
  <description>5 Failed passwords within 10 minutes</description>
</rule>
```

There are several additional tags that you can use to create more granular composite rules. These rules, as shown in the following table, allow you to specify that certain parts of the event must be the same. This allows you to tune your composite rules and reduce false positives:

Tag	Description
<code>same_source_ip</code>	Specifies that the source IP address must be the same.
<code>same_dest_ip</code>	Specifies that the destination IP address must be the same.
<code>same_dst_port</code>	Specifies that the destination port must be the same.
<code>same_location</code>	Specifies that the location (hostname or agent name) must be the same.
<code>same_user</code>	Specifies that the decoded username must be the same.
<code>same_id</code>	Specifies that the decoded id must be the same.

If you wanted your composite rule to alert on every authentication failure, instead of a specific rule ID, you could replace the `<if_matched_sid></if_matched_sid>` tag with the `<if_matched_group></if_matched_group>` tag. This allows you to specify a category, such as **authentication_failure**, to search for authentication failures across your entire infrastructure.

```
<rule id="100130" level="10" frequency="5" timeframe="600">
  <if_matched_group>authentication_failure</if_matched_group>
  <same_source_ip />
  <description>5 Failed passwords within 10 minutes</description>
</rule>
```

In addition to `<if_matched_sid></if_matched_sid>` and `<if_matched_group></if_matched_group>` tags, you can also use the `<if_matched_regex></if_matched_regex>` tag to specify a regular expression to search through logs as they are received.

```
<rule id="100130" level="10" frequency="5" timeframe="600">
  <if_matched_regex>^Failed password</if_matched_regex>
  <same_source_ip />
```

```
<description>5 Failed passwords within 10 minutes</description>  
</rule>
```

Real world examples

Deep Security includes many default Log Inspection rules for dozens of common and popular applications. Through Security Updates, new rules are added regularly. In spite of the growing list of applications supported by Log Inspection rules, you may find the need to create a custom rule for an unsupported or custom application.

In this section we will walk through the creation of a custom CMS (content management system) hosted on Microsoft Windows Server with IIS and .Net platform, with a Microsoft SQL Server database as the data repository.

The first step is to identify the following application logging attributes:

1. Where does the application log to?
2. Which Log Inspection decoder can be used to decode the log file?
3. What is the general format of a log file message?

For our custom CMS example the answers are as follows:

1. Windows Event Viewer
2. Windows Event Log (eventlog)
3. Windows Event Log Format with the following core attributes:
 - Source: CMS
 - Category: None
 - Event: <Application Event ID>

The second step is to identify the categories of log events by application feature, and then organize the categories into a hierarchy of cascading groups for inspection. Not all inspected groups need to raise events; a match can be used as a conditional statement. For each group, identify the log format attributes which the rule can use as matching criteria. This can also be performed by inspecting all application logs for patterns and logical groupings of log events.

For example, the CMS application supports the following functional features which we will create Log Inspection rules for:

- CMS Application Log (Source: CMS)
 - Authentication (Event: 100 to 119)
 - User Login successful (Event: 100)
 - User Login unsuccessful (Event: 101)
 - Administrator Login successful (Event: 105)
 - Administrator Login unsuccessful (Event: 106)
 - General Errors (Type: Error)
 - Database error (Event: 200 to 205)
 - Runtime error (Event: 206-249)
 - Application Audit (Type: Information)
 - Content
 - New content added (Event: 450 to 459)
 - Existing content modified (Event: 460 to 469)
 - Existing content deleted (Event: 470 to 479)
 - Administration
 - User
 - New User created (Event: 445 to 446)
 - Existing User deleted (Event: 447 to 449)

This structure will provide you with a good basis for rule creation. Now to create a new Log Inspection rule in Deep Security Manager.

To create the new CMS Log Inspection Rule:

1. In the Deep Security Manager, go to **Policies > Common Objects > Rules > Log Inspection Rules** and click **New** to display the **New Log Inspection Rule Properties** window.
2. Give the new rule a name and a description, and then click the **Content** tab.
3. The quickest way to create a new custom rule is to start with a basic rule template. Select the **Basic Rule** radio button.
4. The **Rule ID** field will be automatically populated with an unused ID number of 100,000 or greater, the IDs reserved for custom rules.
5. Set the **Level** setting to **Low (0)**.
6. Give the rule an appropriate Group name. In this case, "cms".

7. Provide a short rule description.

General	Content	Files	Options	Assigned To	
Template					
<input checked="" type="radio"/> Basic Rule					
<input type="radio"/> Custom (XML)					
General Information					
Rule ID:	<input type="text" value="100000"/>				
Level:	<input type="text" value="Low (0)"/>				
Groups (comma separated):	<input type="text" value="cms"/>				
Rule Description:	<input type="text" value="windows events for 'cms' group"/>				
Pattern Matching					
Pattern to Match:	<input type="text"/>				
Pattern Type:	<input type="text" value="String Pattern"/>				
Dependency					
<input checked="" type="radio"/> None					
<input type="radio"/> Trigger event on the triggering of another rule:					
<input type="radio"/> Trigger event on the triggering of any rule belonging to a specific group:					
Composite (optional)					
Only trigger if this rule matches its dependent rule the specified frequency of times in the specified time frame (in seconds).					
Frequency (1 to 128):	<input type="text"/>				
Time Frame (1 to 86400):	<input type="text"/>				
				<input type="button" value="OK"/>	<input type="button" value="Cancel"/>

8. Now select the **Custom (XML)** option. The options you selected for your "Basic" rule will be converted to XML.

General Content Files Options Assigned To

Template

Basic Rule

Custom (XML)

Content:

```
<group name="cms">
  <rule id="100000" level="0">
    <description>windows events for 'cms' groups</description>
  </rule>
</group>
```

OK Cancel

9. Click the **Files** tab and click the **Add File** button to add any application log files and log types which the rule will be applied to. In this case, "Application", and "eventlog" as the file type.

General Content Files Options Assigned To

Files:

Application eventlog Remove

Add File

OK Cancel

Note: Eventlog is a unique file type in Deep Security because the location and filename of the log files don't have to be specified. Instead, it is sufficient to type the log name as it is displayed in the Windows Event Viewer. Other log names for the eventlog file type

might be "Security", "System", "Internet Explorer", or any other section listed in the Windows Event Viewer. Other file types will require the log file's location and filename. (C/C++ *strftime()* conversion specifiers are available for matching on filenames. See the table below for a list of some of the more useful ones.)

10. Click **OK** to save the basic rule.
11. Working with the basic rule Custom (XML) created, we can begin adding new rules to the group based on the log groupings identified previously. We will set the base rule criteria to the initial rule. In the following example, the CMS base rule has identified Windows Event Logs with a Source attribute of "CMS":

```
<group name="cms">
  <rule id="100000" level="0">
    <category>windows</category>
    <extra_data>^CMS</extra_data>
    <description>Windows events from source 'CMS' group
messages.</description>
  </rule>
```

12. Now we build up subsequent rules from the identified log groups. The following example identifies the authentication and login success and failure and logs by Event IDs.

```
<rule id="100001" level="0">
  <if_sid>100000</if_sid>
  <id>^100|^101|^102|^103|^104|^105|^106|^107|^108|^109|^110</id>
  <group>authentication</group>
  <description>CMS Authentication event.</description>
</rule>

<rule id="100002" level="0">
  <if_group>authentication</if_group>
  <id>100</id>
  <description>CMS User Login success event.</description>
</rule>

<rule id="100003" level="4">
  <if_group>authentication</if_group>
  <id>101</id>
  <group>authentication_failure</group>
  <description>CMS User Login failure event.</description>
</rule>
```

```

<rule id="100004" level="0">
  <if_group>authentication</if_group>
  <id>105</id>
  <description>CMS Administrator Login success event.</description>
</rule>
<rule id="100005" level="4">
  <if_group>authentication</if_group>
  <id>106</id>
  <group>authentication_failure</group>
  <description>CMS Administrator Login failure event.</description>
</rule>

```

13. Now we add any composite or correlation rules using the established rules. The following example shows a high severity composite rule that is applied to instances where the repeated login failures have occurred 5 times within a 10 second time period:

```

<rule id="100006" level="10" frequency="5" timeframe="10">
  <if_matched_group>authentication_failure</if_matched_group>
  <description>CMS Repeated Authentication Login failure
event.</description>
</rule>

```

14. Review all rules for appropriate severity levels. For example, error logs should have a severity of level 5 or higher. Informational rules would have a lower severity.
15. Finally, open the newly created rule, click the **Configuration** tab and copy your custom rule XML into the rule field. Click **Apply** or **OK** to save the change.

Once the rule is assigned to a policy or computer, the Log Inspection engine should begin inspecting the designated log file immediately.

The complete Custom CMS Log Inspection Rule:

```

<group name="cms">
  <rule id="100000" level="0">
    <category>windows</category>
    <extra_data>^CMS</extra_data>
    <description>Windows events from source 'CMS' group
messages.</description>
  </rule>
  <rule id="100001" level="0">
    <if_sid>100000</if_sid>
    <id>^100|^101|^102|^103|^104|^105|^106|^107|^108|^109|^110</id>
    <group>authentication</group>
  </rule>

```

```

        <description>CMS Authentication event.</description>
</rule>

<rule id="100002" level="0">
    <if_group>authentication</if_group>
    <id>100</id>
    <description>CMS User Login success event.</description>
</rule>

<rule id="100003" level="4">
    <if_group>authentication</if_group>
    <id>101</id>
    <group>authentication_failure</group>
    <description>CMS User Login failure event.</description>
</rule>

<rule id="100004" level="0">
    <if_group>authentication</if_group>
    <id>105</id>
    <description>CMS Administrator Login success event.</description>
</rule>

<rule id="100005" level="4">
    <if_group>authentication</if_group>
    <id>106</id>
    <group>authentication_failure</group>
    <description>CMS Administrator Login failure event.</description>
</rule>

<rule id="100006" level="10" frequency="5" timeframe="10">
    <if_matched_group>authentication_failure</if_matched_group>
    <description>CMS Repeated Authentication Login failure
event.</description>
</rule>

<rule id="100007" level="5">
    <if_sid>100000</if_sid>
    <status>^ERROR</status>
    <description>CMS General error event.</description>
    <group>cms_error</group>

```

```

</rule>

<rule id="100008" level="10">
  <if_group>cms_error</if_group>
  <id>^200|^201|^202|^203|^204|^205</id>
  <description>CMS Database error event.</description>
</rule>

<rule id="100009" level="10">
  <if_group>cms_error</if_group>
  <id>^206|^207|^208|^209|^230|^231|^232|^233|^234|^235|^236|^237|^238|^239|^240|^241|^242|^243|^244|^245|^246|^247|^248|^249</id>
  <description>CMS Runtime error event.</description>
</rule>

<rule id="100010" level="0">
  <if_sid>100000</if_sid>
  <status>^INFORMATION</status>
  <description>CMS General informational event.</description>
  <group>cms_information</group>
</rule>

<rule id="100011" level="5">
  <if_group>cms_information</if_group>
  <id>^450|^451|^452|^453|^454|^455|^456|^457|^458|^459</id>
  <description>CMS New Content added event.</description>
</rule>

<rule id="100012" level="5">
  <if_group>cms_information</if_group>
  <id>^460|^461|^462|^463|^464|^465|^466|^467|^468|^469</id>
  <description>CMS Existing Content modified event.</description>
</rule>

<rule id="100013" level="5">
  <if_group>cms_information</if_group>
  <id>^470|^471|^472|^473|^474|^475|^476|^477|^478|^479</id>
  <description>CMS Existing Content deleted event.</description>
</rule>

```

```

<rule id="100014" level="5">
  <if_group>cms_information</if_group>
  <id>^445|^446</id>
  <description>CMS User created event.</description>
</rule>

<rule id="100015" level="5">
  <if_group>cms_information</if_group>
  <id>^447|449</id>
  <description>CMS User deleted event.</description>
</rule>

</group>

```

Log Inspection rule severity levels and their recommended use

Level	Description	Notes
Level 0	Ignored, no action taken	Primarily used to avoid false positives. These rules are scanned before all the others and include events with no security relevance.
Level 1	no predefined use	
Level 2	System low priority notification	System notification or status messages that have no security relevance.
Level 3	Successful or authorized events	Successful login attempts, firewall allow events, etc.
Level 4	System low priority errors	Errors related to bad configurations or unused devices or applications. They have no security relevance and are usually caused by default installations or software testing.
Level 5	User-generated errors	Missed passwords, denied actions, etc. These messages typically have no security relevance.
Level 6	Low relevance attacks	Indicate a worm or a virus that provide no threat to the system such as a Windows worm attacking a Linux server. They also include frequently triggered IDS events and common error events.
Level 7	no predefined use	
Level 8	no predefined use	
Level 9	Error from invalid	Include attempts to login as an unknown user or from an invalid source. The message might have security relevance especially if repeated. They also

Level	Description	Notes
	source	include errors regarding the admin or root account.
Level 10	Multiple user generated errors	Include multiple bad passwords, multiple failed logins, etc. They might indicate an attack, or it might be just that a user forgot his or her credentials.
Level 11	no predefined use	
Level 12	High-importance event	Include error or warning messages from the system, kernel, etc. They might indicate an attack against a specific application.
Level 13	Unusual error (high importance)	Common attack patterns such as a buffer overflow attempt, a larger than normal syslog message, or a larger than normal URL string.
Level 14	High importance security event	Typically the result of the correlation of multiple attack rules and indicative of an attack.
Level 15	Attack Successful	Very small chance of false positive. Immediate attention is necessary.

***strftime()* conversion specifiers**

Specifier	Description
%a	Abbreviated weekday name (e.g., Thu)
%A	Full weekday name (e.g., Thursday)
%b	Abbreviated month name (e.g., Aug)
%B	Full month name (e.g., August)
%c	Date and time representation (e.g., Thu Sep 22 12:23:45 2007)
%d	Day of the month (01 - 31) (e.g., 20)
%H	Hour in 24 h format (00 - 23) (e.g., 13)
%I	Hour in 12 h format (01 - 12) (e.g., 02)
%j	Day of the year (001 - 366) (e.g., 235)
%m	Month as a decimal number (01 - 12) (e.g., 02)
%M	Minute (00 - 59) (e.g., 12)
%p	AM or PM designation (e.g., AM)
%S	Second (00 - 61) (e.g., 55)
%U	Week number with the first Sunday as the first day of week one (00 - 53) (e.g., 52)
%w	Weekday as a decimal number with Sunday as 0 (0 - 6) (e.g., 2)
%W	Week number with the first Monday as the first day of week one (00 - 53) (e.g., 21)
%x	Date representation (e.g., 02/24/79)
%X	Time representation (e.g., 04:12:51)
%y	Year, last two digits (00 - 99) (e.g., 76)
%Y	Year (e.g., 2008)
%Z	Time zone name or abbreviation (e.g., EST)

Specifier	Description
%%	A % sign (e.g., %)

More information can be found at the following websites:

<https://www.php.net/manual/en/function.strftime.php>

www.cplusplus.com/reference/clibrary/ctime/

Examine a Log Inspection rule

Log Inspection rules are found in the Deep Security Manager at **Policies > Common Objects > Rules > Log Inspection Rules**.

Log Inspection rule structure and the event matching process

This screen shot displays the contents of the **Configuration** tab of the Properties window of the "Microsoft Exchange" Log Inspection rule:

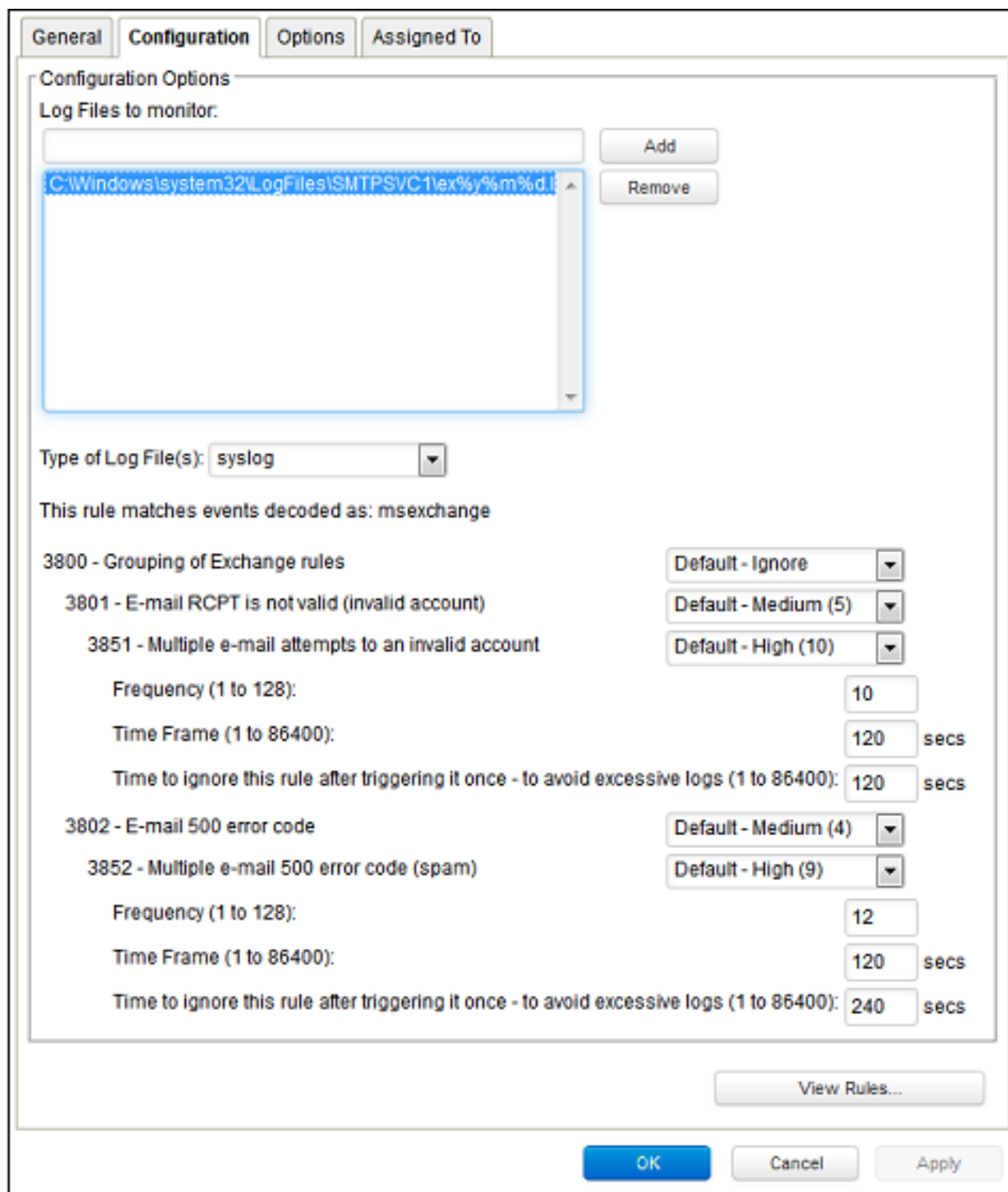

Here is the structure of the rule:

- 3800 - Grouping of Exchange Rules - Ignore
 - 3801 - Email rcpt is not valid (invalid account) - Medium (4)
 - 3851 - Multiple email attempts to an invalid account - High (9)
 - Frequency - 10
 - Time Frame - 120
 - Ignore - 120
 - 3802 - Email 500 error code - Medium (4)
 - 3852 - Email 500 error code (spam) - High (9)
 - Frequency - 12
 - Time Frame - 120
 - Ignore - 240

The Log Inspection engine will apply log events to this structure and see if a match occurs. For example, if an Exchange event occurs, and this event is an email receipt to an invalid account, the event will match line 3800 (because it is an Exchange event). The event will then be applied to line 3800's sub-rules: 3801 and 3802.

If there is no further match, this "cascade" of matches will stop at 3800. Because 3800 has a severity level of "Ignore", no Log Inspection event would be recorded.

However, an email receipt to an invalid account does match one of 3800's sub-rules: sub-rule 3801. Sub-rule 3801 has a severity level of "Medium(4)". If the matching stopped here, a Log Inspection event with a severity level of "Medium(4)" would be recorded.

But there is still another sub-rule to be applied to the event: sub-rule 3851. Sub-rule 3851 with its three attributes will match if the same event has occurred 10 times within the last 120 seconds. If so, a Log Inspection event with a severity "High(9)" is recorded. (The "Ignore" attribute tells sub-rule 3851 to ignore individual events that match sub-rule 3801 for the next 120 seconds. This is useful for reducing "noise".)

Assuming the parameters of sub-rule 3851 have been matched, a Log Inspection event with Severity "High(9)" is now recorded.

Looking at the Options tab of the Microsoft Exchange Rule, we see that Deep Security Manager will raise an alert if any sub-rules with a severity level of "Medium(4)" have been matched. Since this is the case in our example, the alert will be raised (if "Alert when this rule logs an event" is selected).

Duplicate Sub-rules

Some Log Inspection rules have duplicate sub-rules. To see an example, open the "Microsoft Windows Events" rule and click on the **Configuration** tab. Note that sub-rule 18125 (Remote access login failure) appears under sub-rules 18102 and 18103. Also note that in both cases sub-rule 18125 does not have a severity value, it only says "See Below".

Instead of being listed twice, Rule 18125 is listed once at the bottom of the **Configuration** page:

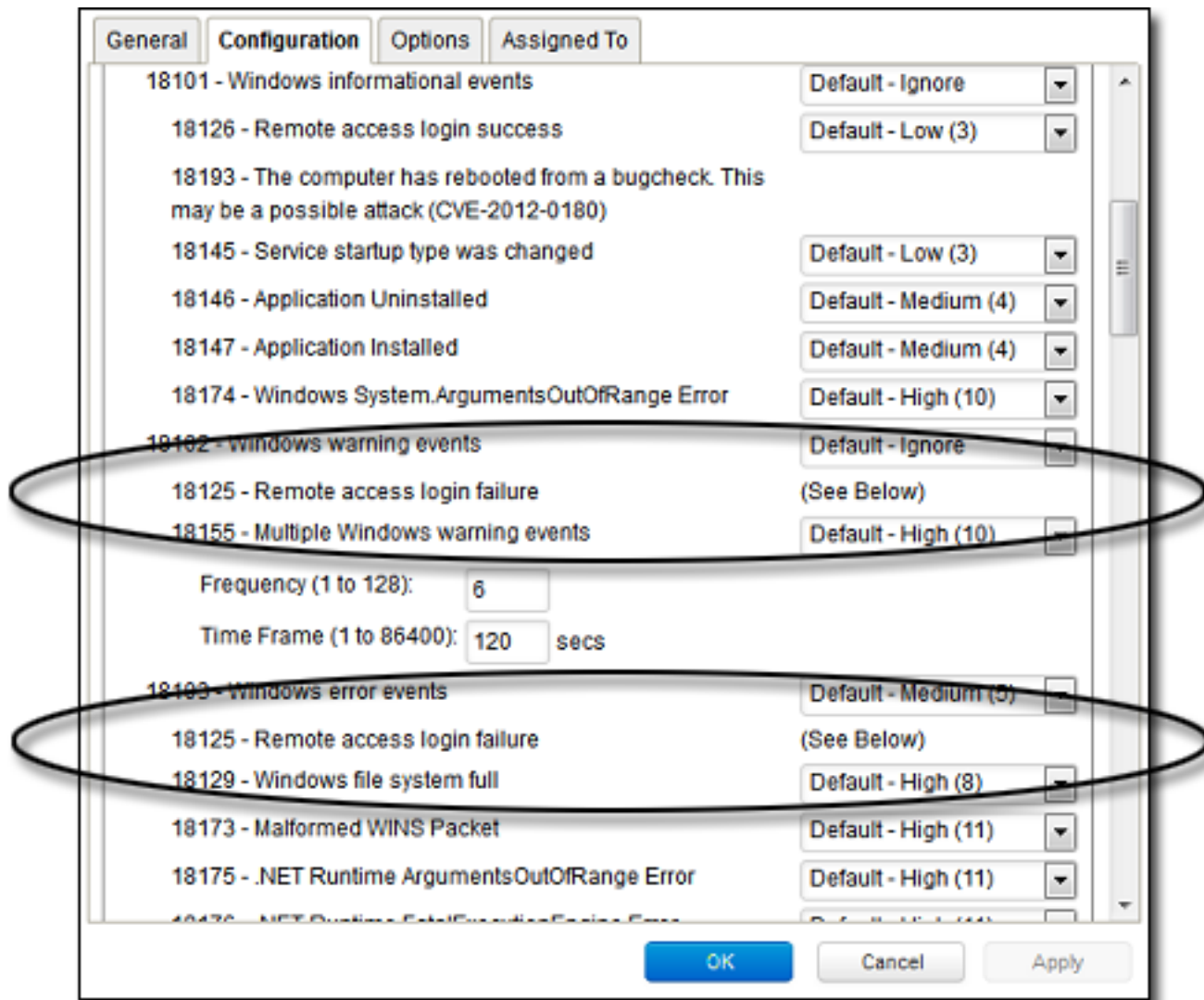

Create a list of directories for use in policies

Create lists of directory paths so that you can use them in multiple policies. A single list is easier to manage than several identical lists that are each created in a different policy. The most common use-cases for these lists are for Anti-Malware scan inclusions or exclusions. For more information, see ["Specify the files to scan" on page 813](#).

Tip: To create a directory list that is similar to an existing one, duplicate the list and then edit it.

The following table describes the syntax for defining directory list items. The use of forward slashes "/" and backslashes "\" are supported for both Windows and Linux conventions:

Directory	Format	Description	Examples
Directory	DIRECTORY	Includes all files in the specified directory and all files in all subdirectories.	C:\Program Files\ Includes all files in the "Program Files" directory and all subdirectories.
Network Resource	\\NETWORK RESOURCE	Includes files on a computer included as a network resource on a targeted computer.	\\12.34.56.78\ \\some-comp-name\ Includes all files on a network resource (and its subfolders) identified using an IP or a hostname. \\12.34.56.78\somefolder\ \\some-comp-name\somefolder\ Includes all files in the folder "somefolder" and its subfolders on a network resource identified using an IP or a hostname.
Directory with wildcard (*)	DIRECTORY*	Includes any subdirectories with any subdirectory name, but does not include the files in the specified directory.	C:\abc* Includes all files in all subdirectories of "abc" but does not include the files in the "abc" directory. C:\abc\wx*z\ <i>Matches:</i> C:\abc\wxz\ C:\abc\wx123z\ <i>Does not match:</i> C:\abc\wxz C:\abc\wx123z

Directory	Format	Description	Examples
			C:\abc*wx\ <i>Matches:</i> C:\abc\wx\ C:\abc\123wx\ <i>Does not match:</i> C:\abc\wx C:\abc\123wx
Directory with wildcard (*)	DIRECTORY*	Includes any subdirectories with a matching name, but does not include the files in that directory and any subdirectories.	C:\abc* <i>Matches:</i> C:\abc\ C:\abc\1 C:\abc\123 <i>Does not match:</i> C:\abc C:\abc\123\ C:\abc\123\456 C:\abx\ C:\xyz\ C:\abc*wx <i>Matches:</i> C:\abc\wx C:\abc\123wx <i>Does not match:</i> C:\abc\wx\ C:\abc\123wx\ C:\abc\wx*z <i>Matches:</i> C:\abc\wxz C:\abc\wx123z <i>Does not match:</i> C:\abc\wxz\ C:\abc\wx123z\ C:\abc\wx* <i>Matches:</i> C:\abc\wx C:\abc\wx\ C:\abc\wx12 C:\abc\wx12\345\ C:\abc\wxz\ <i>Does not match:</i> C:\abc\wx123z\
Environment variable	\${ENV VAR}	Includes all files and subdirectories defined by an environment variable with the format \${ENV VAR}. For a Virtual Appliance, the value pairs for	\${windir} If the variable resolves to "c:\windows", Includes all the files in "c:\windows"

Directory	Format	Description	Examples
		the environment variable must be defined in Policy or Computer Editor > Settings > General > Environment Variable Overrides .	and all its subdirectories.
Comments	DIRECTORY #Comment	Allows you to add comments to your inclusion definitions.	<i>c:\abc #Include the abc directory</i>

1. Click **Policies > Common Objects > Lists > Directory Lists**.
2. Click **New > New Directory List**.
3. Type a name and, optionally, a description.
4. In the **Directory(s)** list, add the directory paths, one per line.
5. Click **OK**.

Import and export directory lists

You can export one or more directory lists to an XML or CSV file, and import lists from an XML file.

1. Click **Policies > Common Objects > Lists > Directory Lists**.
2. To export one or more lists, select them and click **Export > Export Selected to CSV** or **Export > Export Selected to XML**.
3. To export all lists, click **Export > Export to CSV** or **Export > Export to XML**.
4. To import lists, click **New > Import From File** and follow the instructions on the wizard.

See which policies use a directory list

It is useful to see which policies use a directory list to be aware of which policies are affected by any changes you make. For example, you can ensure no policies use a directory list before deleting it.

1. Click **Policies > Common Objects > Lists > Directory Lists**.
2. Select the directory list and click **Properties**.
3. Click the **Assigned To** tab.

Create a list of file extensions for use in policies

Create lists of file extensions so that you can use them in multiple malware scan configurations. A single list is easier to manage than several identical lists that are each created in a different rule. For example, one list of file extensions can be used by multiple malware scan configurations as files to include in a scan. Another list of file extensions can be used by multiple malware scan configurations as files to exclude from a scan.

Tip: To create a file extension list that is similar to an existing one, duplicate the list and then edit it.

You can insert comments into your list by preceding the text with a pound sign ("#").

1. Click **Policies > Common Objects > Lists > File Extension Lists**.
2. Click **New > New File Extension List**.
3. Type a name and, optionally, a description.
4. In the **File Extension(s)** list, add the extensions, one per line.
5. Click **OK**.

Import and export file extension lists

You can export one or more file extension lists to an XML or CSV file, and import lists from an XML file.

1. Click **Policies > Common Objects > Lists > File Extension Lists**.
2. To export one or more lists, select them and click **Export > Export Selected to CSV** or **Export > Export Selected to XML**.
3. To export all lists, click **Export > Export to CSV** or **Export > Export to XML**.
4. To import lists, click **New > Import From File** and follow the instructions on the wizard.

See which malware scan configurations use a file extension list

It is useful to see which malware scan configurations use a file extension list to be aware of which rules are affected by any changes you make. For example, you can ensure no scan configurations use a file extension list before deleting it.

1. Click **Policies > Common Objects > Lists > File Extension Lists**.
2. Select the list and click **Properties**.
3. Click the **Assigned To** tab.

Create a list of files for use in policies

Create lists of file paths so that you can use them in multiple policies. A single list is easier to manage than several identical lists that are each created in a different policy. The most common use-cases for these lists are for Anti-Malware scan inclusions or exclusions. For more information, see "[Specify the files to scan](#)" on page 813.

Tip: To create a file list that is similar to an existing one, duplicate the list and then edit it.

The following table describes the syntax for defining file list items. The use of forward slashes "/" and backslashes "\" are supported for both Windows and Linux conventions:

Inclusion	Format	Description	Example
File	FILE	Includes all files with the specified file name regardless of its location or directory.	abc.doc Includes all files named "abc.doc" in all directories. Does not include "abc.exe".
File path	FILEPATH	Includes the single file specified by the file path.	C:\Documents\abc.doc Includes only the file named "abc.doc" in the "Documents" directory.
File path with wildcard (*)	FILEPATH	Excludes all the files specified by the file path.	C:\Documents\abc.co* (For Windows Agent platforms only) Excludes any file that has file name of "abc" and extension beginning with ".co" in the "Documents" directory.
Filename is a wildcard (*)	FILEPATH*	Excludes all files under the path, but does not include the files in unspecified subdirectories	C:\Documents* Excludes all files under the directory C:\Documents\ C:\Documents\SubDirName* Excludes all files within subdirectories with a folder name that begins with "SubDirName". Does not exclude all files under C:\Documents\ or any other subdirectories. C:\Documents** Excludes all files within all direct subdirectories under C:\Documents. Does not exclude files in subsequent subdirectories.
File with wildcard (*)	FILE*	Includes all files with a matching pattern in the file name.	abc*.exe Includes any file that has prefix of "abc" and extension of ".exe". *.db <i>Matches:</i> 123.db abc.db

Inclusion	Format	Description	Example
			<p><i>Does not match:</i> 123db 123.abd cbc.dba</p> <p>*db <i>Matches:</i> 123.db 123db ac.db acdb db</p> <p><i>Does not match:</i> db123</p> <p>wxy*.db <i>Matches:</i> wxy.db wxy123.db</p> <p><i>Does not match:</i> wxydb</p>
File with wildcard (*)	FILE.EXT*	Includes all files with a matching pattern in the file extension.	<p>abc.v* Includes any file that has file name of "abc" and extension beginning with ".v".</p> <p>abc.*pp <i>Matches:</i> abc.pp abc.app</p> <p><i>Does not match:</i> wxy.app</p> <p>abc.a*p <i>Matches:</i> abc.ap abc.a123p</p> <p><i>Does not match:</i> abc.pp</p> <p>abc.* <i>Matches:</i> abc.123 abc.xyz</p> <p><i>Does not match:</i> wxy.123</p>
File with wildcard (*)	FILE*.EXT*	Includes all files with a matching pattern in the file name and in the	a*c.a*p

Inclusion	Format	Description	Example
		extension.	<i>Matches:</i> ac.ap a123c.ap ac.a456p a123c.a456p <i>Does not match:</i> ad.aa
Environment variable	<code>\${ENV VAR}</code>	Includes files specified by an environment variable with the format <code>\${ENV VAR}</code> . These can be defined or overridden using Policy or Computer Editor > Settings > General > Environment Variable Overrides .	<code>\${myDBFile}</code> Includes the file "myDBFile".
Comments	<code>FILEPATH #Comment</code>	Allows you to add comments to your inclusion definitions.	<code>C:\Documents\abc.doc #This a comment</code>

1. Click **Policies > Common Objects > Lists > File Lists**.
2. Click **New > New File List**.
3. Type a name and, optionally, a description.
4. In the **File(s)** list, add the file paths, one per line.
5. Click **OK**.

Import and export file lists

You can export one or more file lists to an XML or CSV file, and import lists from an XML file.

1. Click **Policies > Common Objects > Lists > File Lists**.
2. To export one or more lists, select them and click **Export > Export Selected to CSV** or **Export > Export Selected to XML**.
3. To export all lists, click **Export > Export to CSV** or **Export > Export to XML**.
4. To import lists, click **New > Import From File** and follow the instructions on the wizard.

See which policies use a file list

It is useful to see which policies use a file list to be aware of which policies are affected by any changes you make. For example, you can ensure no policies use a file list before deleting it.

1. Click **Policies > Common Objects > Lists > File Lists**.
2. Select the file list and click **Properties**.
3. Click the **Assigned To** tab.

Create a list of IP addresses for use in policies

Create lists of IP addresses so that you can use them in multiple firewall rules. A single list is easier to manage than several identical lists that are each defined in a different rule.

Tip: To create an IP list that is similar to an existing one, duplicate the list and then edit it.

You can enter an individual IP address, or you can enter IP ranges and masked IPs. You can also insert comments into your IP list by preceding the text with a hash sign ("#").

Masked IP examples are 192.168.0/24, 192.168.2.0/255.255.255.0, and for IPV6 2001:0DB8::CD30:0:0:0/ffff:ffff:fff0::.. IP range examples are 192.168.0.2 - 192.168.0.125 and, for IPV6, FF01::101 - FF01::102

1. Click **Policies > Common Objects > Lists > IP Lists**.
2. Click **New > New IP List**.
3. Type a name and, optionally, a description.
4. In the **IP(s)** list, add the IP addresses, masked IP addresses, or IP ranges (one per line).
5. Click **OK**.

Import and export IP lists

You can export one or more IP lists to an XML or CSV file, and import lists from an XML file.

1. Click **Policies > Common Objects > Lists > IP Lists**.
2. To export one or more lists, select them and click **Export > Export Selected to CSV** or **Export > Export Selected to XML**.
3. To export all lists, click **Export > Export to CSV** or **Export > Export to XML**.
4. To import lists, click **New > Import From File** and follow the instructions on the wizard.

See which rules use an IP list

It is useful to see which firewall rules use an IP list to be aware of which rules are affected by any changes you make. For example, you can ensure no firewall rules use an IP list before deleting it.

1. Click **Policies > Common Objects > Lists > IP Lists**.
2. Select the IP list and click **Properties**.
3. Click the **Assigned To** tab.

Create a list of ports for use in policies

Create lists of port numbers so that you can use them in multiple rules. A single list is easier to manage than several identical lists that are each created in a different rule.

Tip: To create a port list that is similar to an existing one, duplicate the list and then edit it.

Individual ports and port ranges can be included on the list, for example 80, and 20-21. You can insert comments into your port list by preceding the text with a pound sign ("#").

Note: For a listing commonly accepted port number assignments, see the [Internet Assigned Numbers Authority \(IANA\)](#). For a list of port numbers used by Deep Security Manager, Relay, or Agent, see "[Port numbers, URLs, and IP addresses](#)" on page 410.

1. Click **Policies > Common Objects > Lists > Port Lists**.
2. Click **New > New Port List**.
3. Type a name and, optionally, a description.
4. In the **Port(s)** list, add the port numbers, one per line.
5. Click **OK**.

Import and export port lists

You can export one or more port lists to an XML or CSV file, and import lists from an XML file.

1. Click **Policies > Common Objects > Lists > Port Lists**.
2. To export one or more lists, select them and click **Export > Export Selected to CSV** or **Export > Export Selected to XML**.
3. To export all lists, click **Export > Export to CSV** or **Export > Export to XML**.
4. To import lists, click **New > Import From File** and follow the instructions on the wizard.

See which rules use a port list

It is useful to see which rules use a port list to be aware of which rules are affected by any changes you make. For example, you can ensure no rules use a port list before deleting it.

1. Click **Policies > Common Objects > Lists > Port Lists**.
2. Select the port list and click **Properties**.
3. Click the **Assigned To** tab.

Create a list of MAC addresses for use in policies

Create lists of MAC addresses so that you can use them in multiple policies. A single list is easier to manage than several identical lists that are each created in a different policy.

Tip: To create a MAC list that is similar to an existing one, duplicate the list and then edit it.

MAC lists support MAC addresses in both hyphen- and colon-separated formats, for example 0A-0F-FF-F0-A0-AF and 0A:0F:FF:F0:A0:AF. You can insert comments into your MAC list by preceding the text with a pound sign ("#").

1. Click **Policies > Common Objects > Lists > MAC Lists**.
2. Click **New > New MAC List**.
3. Type a name and, optionally, a description.
4. In the **MAC(s)** list, add the MAC addresses, one per line.
5. Click **OK**.

Import and export MAC lists

You can export one or more MAC lists to an XML or CSV file, and import lists from an XML file.

1. Click **Policies > Common Objects > Lists > MAC Lists**.
2. To export one or more lists, select them and click **Export > Export Selected to CSV** or **Export > Export Selected to XML**.
3. To export all lists, click **Export > Export to CSV** or **Export > Export to XML**.
4. To import lists, click **New > Import From File** and follow the instructions on the wizard.

See which policies use a MAC list

It is useful to see which policies use a MAC list to be aware of which policies are affected by any changes you make. For example, you can ensure no policies use a MAC list before deleting it.

1. Click **Policies > Common Objects > Lists > MAC Lists**.
2. Select the MAC list and click **Properties**.
3. Click the **Assigned To** tab.

Define contexts for use in policies

Contexts are a powerful way of implementing different security policies depending on a computer's network environment.

Contexts are designed to be associated with firewall and intrusion prevention rules. If the conditions defined in the context associated with a rule are met, the rule is applied.

Configure settings used to determine whether a computer has internet connectivity

1. In the Deep Security Manager, go to **Administration > System Settings > Contexts**.
2. In the **URL for testing Internet Connectivity Status** box, enter the URL to which an HTTP request will be sent to test for internet connectivity. (You must include "http://".)
3. In the **Regular Expression for returned content used to confirm Internet Connectivity Status** box, enter a regular expression that will be applied to the returned content to confirm that HTTP communication was successful. (If you are certain of the returned content, you can use a simple string of characters.)
4. In the **Test Interval** list, select the time interval between connectivity tests.

For example, to test Internet connectivity, you could use the URL "**http://www.example.com**", and the string "**This domain is established to be used for illustrative examples in documents**" which is returned by the server at that URL.

Define a context

1. In the Deep Security Manager, go to **Policies > Common Objects > Other > Contexts** and then click **New > New Context**.
2. In the **General Information** area, enter the name and description of the context rule. This area also displays the earliest version of the Deep Security Agent the rule will be compatible with.
3. In the **Options** area, specify when the context will be applied:
 - **Context applies when connection is:** Specifying an option here will determine whether the Firewall rule is in effect depending on the ability of the computer to connect to its domain controller or its internet connectivity. (Conditions for testing internet connectivity can be configured in **Administration > System Settings > Contexts**.)

If the domain controller can be contacted directly (via ICMP), the connection is "Local". If it can be contacted via VPN only, then the connection is "Remote".

The time interval between domain controller connectivity tests is the same as the internet connectivity test interval, which is configurable in **Administration > System Settings > Contexts**. The internet connectivity test is only performed if the computer is unable to connect to its domain controller.

- **Context Applies to Interface Isolation Restricted Interfaces:** This context will apply to network interfaces on which traffic has been restricted through the use of interface isolation. This is primarily used for "Allow" or "Force Allow" Firewall rules. See ["Detect and configure the interfaces available on a computer" on page 716](#).

After you assign the context to a rule, it is displayed on the **Assigned To** tab for the context. (To link a security rule to a context, go to the **Options** tab in the security rule's **Properties** window and select the context from the "Context" list.)

Define stateful firewall configurations

Deep Security's stateful firewall configuration mechanism analyzes each packet in the context of traffic history, correctness of TCP and IP header values, and TCP connection state transitions. In the case of stateless protocols like UDP and ICMP, a pseudo-stateful mechanism is implemented based on historical traffic analysis. Packets are handled by the stateful mechanism as follows:

1. A packet is passed to the stateful routine if it has been allowed through by the static firewall rule conditions,
2. The packet is examined to determine whether it belongs to an existing connection, and
3. The TCP header is examined for correctness (e.g. sequence numbers, flag combinations, etc.).

To create a new stateful configuration, you need to:

1. ["Add a stateful configuration " below](#).
2. ["Enter stateful configuration information" on the next page](#).
3. ["Select packet inspection options" on the next page](#).

When you're done with your stateful configuration, you can also learn how to

- ["See policies and computers a stateful configuration is assigned to" on page 797](#)
- ["Export a stateful configuration " on page 796](#)
- ["Delete a stateful configuration " on page 797](#)

Add a stateful configuration

There are three ways to define a stateful configuration on the **Policies > Common Objects > Other > Firewall Stateful Configurations** page:

- Create a new configuration. Click **New > New Firewall Stateful Configuration**.
- Import a configuration from an XML file. Click **New > Import From File**.
- Copy and then modify an existing configuration. Right-click the configuration in the Firewall Stateful Configurations list and then click **Duplicate**. To edit the new configuration, select it and then click **Properties**.

Enter stateful configuration information

Enter a **Name** and **Description** for the configuration.

Select packet inspection options

You can define options for IP, TCP, UDP and ICMP packet inspection, and enable Active or Passive FTP.

IP packet inspection

Under the **General** tab, select the **Deny all incoming fragmented packets** to drop any fragmented packets. Dropped packets will bypass fragmentation analysis and generate an "IP fragmented packet" log entry. Packets with a total length smaller than the IP header length are dropped silently.

Warning: Attackers sometimes create and send fragmented packets in an attempt to bypass Firewall Rules.

Note: The Firewall Engine, by default, performs a series of checks on fragmented packets. This is default behavior and cannot be reconfigured. Packets with the following characteristics are dropped:

- **Invalid fragmentation flags/offset:** A packet is dropped when either the **DF** and **MF** flags in the IP header are set to 1, or the header contains the **DF** flag set to 1 and an **Offset** value different than 0.
- **First fragment too small:** A packet is dropped if its **MF** flag is set to 1, its **Offset** value is at 0, and it has total length of less than 120 bytes (the maximum combined header length).
- **IP fragment out of boundary:** A packet is dropped if its **Offset** flag value combined with the total packet length exceeds the maximum datagram length of 65535 bytes.

- **IP fragment offset too small:** A packet is dropped if it has a non-zero **Offset** flag with a value that is smaller than 60 bytes.

TCP packet inspection

Under the **TCP** tab, select which of the following options you would like to enable:

- **Deny TCP packets containing CWR, ECE flags:** These flags are set when there is network congestion.

Note: RFC 3168 defines two of the six bits from the Reserved field to be used for ECN (Explicit Congestion Notification), as follows:

- Bits 8 to 15: CWR-ECE-URG-ACK-PSH-RST-SYN-FIN
- TCP Header Flags Bit Name Reference:
 - Bit 8: CWR (Congestion Window Reduced) [RFC3168]
 - Bit 9: ECE (ECN-Echo) [RFC3168]

Warning: Automated packet transmission (such as that generated by a denial of service attack, among other things) will often produce packets in which these flags are set.

- **Enable TCP stateful inspection:** Enable stateful inspection at the TCP level. If you enable stateful TCP inspection, the following options become available:
 - **Enable TCP stateful logging:** TCP stateful inspection events will be logged.
 - **Limit the number of incoming connections from a single computer to:** Limiting the number of connections from a single computer can lessen the effect of a denial of service attack.
 - **Limit the number of outgoing connections to a single computer to:** Limiting the number of outgoing connections to a single computer can significantly reduce the effects of Nimda-like worms.
 - **Limit the number of half-open connections from a single computer to:** Setting a limit here can protect you from DoS attacks like SYN Flood. Although most servers have timeout settings for closing half-open connections, setting a value here can prevent half-open connections from becoming a significant problem. If the specified limit for SYN-SENT (remote) entries is reached, subsequent TCP packets from that specific computer will be dropped.

Note: When deciding on how many open connections from a single computer to allow, choose your number from somewhere between what you would consider a reasonable number of half-open connections from a single computer for the type of protocol being used, and how many half-open connections from a single computer your system can maintain without getting congested.

- **Enable ACK Storm protection when the number of already acknowledged packets exceeds:** Set this option to log an event that an ACK Storm attack has occurred.
 - **Drop Connection when ACK Storm detected:** Set this option to drop the connection if such an attack is detected.

Note: ACK Storm protection options are only available on Deep Security Agent 8.0 and earlier.

FTP Options

Under the **FTP Options** tab, you can enable the following options:

Note: The following FTP options are available in Deep Security Agent version 8.0 and earlier.

- **Active FTP**
 - **Allow Incoming:** Allow Active FTP when this computer is acting as a server.
 - **Allow Outgoing:** Allow Active FTP when this computer is acting as client.
- **Passive FTP**
 - **Allow Incoming:** Allow Passive FTP when this computer is acting as a server.
 - **Allow Outgoing:** Allow Passive FTP when this computer is acting as a client.

UDP packet inspection

Under the **UDP** tab, you can enable the following options:

- **Enable UDP stateful inspection:** Select to enable stateful inspection of UDP traffic.

Note: The UDP stateful mechanism drops unsolicited incoming UDP packets. For every outgoing UDP packet, the rule will update its UDP "stateful" table and will then only allow a UDP response if it occurs within 60 seconds of the request. If you wish to allow specific incoming UDP traffic, you will have to create a **Force Allow** rule. For example, if

you are running a DNS server, you will have to create a **Force Allow** rule to allow incoming UDP packets to destination port 53.

Warning: Without stateful inspection of UDP traffic, an attacker can masquerade as a DNS server and send unsolicited UDP "replies" from source port 53 to computers behind a firewall.

- **Enable UDP stateful logging:** Selecting this option will enable the logging of UDP stateful inspection events.

ICMP packet inspection

Under the **ICMP** tab, you can enable the following options:

Note: ICMP stateful inspection is available in Deep Security Agent version 8.0 or earlier.

- **Enable ICMP stateful inspection:** Select to enable stateful inspection of ICMP traffic.

Note: The ICMP (pseudo-)stateful mechanism drops incoming unsolicited ICMP packets. For every outgoing ICMP packet, the rule will create or update its ICMP "stateful" table and will then only allow a ICMP response if it occurs within 60 seconds of the request. (ICMP pair types supported: Type 0 & 8, 13 & 14, 15 & 16, 17 & 18.)

Warning: With stateful ICMP inspection enabled, you can, for example, only allow an ICMP echo-reply in if an echo-request has been sent out. Unrequested echo-replies could be a sign of several kinds of attack including a Smurf amplification attack, a Tribe Flood Network communication between master and daemon, or a Loki 2 back-door.

- **Enable ICMP stateful logging:** Selecting this option will enable the logging of ICMP stateful inspection events.

Export a stateful configuration

You can export all stateful configurations to a .csv or .xml file by clicking **Export** and selecting the corresponding export action from the list. You can also export specific stateful configurations by first selecting them, clicking **Export** and then selecting the corresponding export action from the list.

Delete a stateful configuration

To delete a stateful configuration, right-click the configuration in the Firewall Stateful Configurations list, click **Delete** and then click **OK**.

Note: Stateful configurations that are assigned to one or more computers or that are part of a policy cannot be deleted.

See policies and computers a stateful configuration is assigned to

You can see which policies and computers are assigned to a stateful inspection configuration on the **Assigned To** tab. Click on a policy or computer in the list to see their properties.

Define a schedule that you can apply to rules

Schedules are reusable timetables that you can assign to rules, agent upgrades, and more.

1. In Deep Security Manager, go to **Policies > Common Objects > Other > Schedules**.
2. Click **New > New Schedule**.
3. In the **General Information** area, enter a name and description used to identify the schedule.
4. Click a time block in the grid to select it. To deselect it, click it while pressing Shift. Schedule periods are defined by hour-long time blocks.

After you assign the schedule to a rule, it is displayed on the **Assigned To** tab for the schedule. To link a security rule to a schedule, go to the **Options** tab in the security rule's **Properties** window and select the schedule from the "Schedule" list.

Note: With agent-based protection, schedules use the same time zone as the protected computer's operating system. With agentless protection, schedules use the same time zone as the Deep Security Virtual Appliance.

Configure protection modules

Configure Anti-Malware

About Anti-Malware

The Deep Security anti-malware module provides agent computers with both real-time and on-demand protection against file-based threats, including malware, viruses, Trojans, and spyware. To identify threats, the anti-malware module checks files on the local hard drive against a comprehensive threat database. The anti-malware module also checks files for certain characteristics, such as compression and known exploit code.

Portions of the threat database are hosted on Trend Micro servers or stored locally as patterns. Deep Security Agents periodically download anti-malware patterns and updates to ensure protection against the latest threats.

Note: A newly installed Deep Security Agent cannot provide anti-malware protection until it has contacted an update server to download anti-malware patterns and updates. Ensure that your Deep Security Agents can communicate with a Deep Security Relay or the Trend Micro Update Server after installation.

The anti-malware module eliminates threats while minimizing the impact on system performance. The anti-malware module can clean, delete, or quarantine malicious files. It can also terminate processes and delete other system objects that are associated with identified threats.

To turn on and configure the anti-malware module, see ["Enable and configure anti-malware" on page 805](#).

- ["Types of malware scans" on the next page](#)
- ["Malware scan configurations" on page 800](#)
- ["Malware events" on page 801](#)
- ["SmartScan" on page 801](#)
- ["Predictive Machine Learning" on page 802](#)
- ["Threat Intelligence" on page 802](#)
- ["Types of malware scans" on the next page](#)

Types of malware scans

The anti-malware module performs several types of scans. See also ["Select the types of scans to perform" on page 806](#).

Real-time scan

Scan immediately each time a file is received, opened, downloaded, copied, or modified, Deep Security scans the file for security risks. If Deep Security detects no security risk, the file remains in its location and users can proceed to access the file. If Deep Security detects a security risk, it displays a notification message that shows the name of the infected file and the specific security risk.

Real-time scans are in effect continuously unless another time period is configured using the Schedule option.

Tip: You can configure real-time scanning to run when it will not have a large impact on performance; for example, when a file server is scheduled to back up files.

This scan can run on all platforms supported by the anti-malware module.

Manual scan

Runs a full system scan on all processes and files on a computer. The time required to complete a scan depends on the number of files to scan and the computer's hardware resources. A manual scan requires more time than a Quick Scan.

A manual scan executes when **Full Scan for Malware** is clicked.

This scan can be run on all platforms supported by the anti-malware module.

Scheduled scan

Runs automatically on the configured date and time. Use scheduled scan to automate routine scans and improve scan management efficiency.

A scheduled scan runs according to the date and time you specify when you create a **Scan computers for Malware task** using scheduled tasks (see ["Schedule Deep Security to perform tasks" on page 1766](#)).

This scan can be run on all platforms supported by the anti-malware module.

Quick scan

Only scans a computer's critical system areas for currently active threats. A Quick Scan will look for currently active malware but it will not perform deep file scans to look for dormant or stored infected files. It is significantly faster than a Full Scan on larger drives. Quick scan is not configurable.

A Quick Scan runs when you click **Quick Scan for Malware**.

Note: Quick Scan can run only on Windows computers.

Scan objects and sequence

The following table lists the objects scanned during each type of scan and the sequence in which they are scanned.

Targets	Full Scan (Manual or Scheduled)	Quick Scan
Drivers	1	1
Trojan	2	2
Process Image	3	3
Memory	4	4
Boot Sector	5	-
Files	6	5
Spyware	7	6

Malware scan configurations

Malware scan configurations are sets of options that control the behavior of malware scans. When you configure anti-malware using a policy or for a specific computer, you select a malware scan configuration to use. You can create several malware scan configurations and use them with different policies when different groups of computers have different scan requirements.

Real-time, manual, and scheduled scans all use malware scan configurations. Deep Security provides a default malware scan configuration for each type of scan. These scan configurations are used in the default security policies. You can use the default scan configurations as-is, modify them, or create your own.

Note: Quick Scans are not configurable, and do not use malware scan configurations.

You can specify which files and directories are included or excluded during a scan and which actions are taken if malware is detected on a computer (for example, clean, quarantine, or delete).

For more information, see ["Configure malware scans and exclusions" on page 808](#).

Malware events

When Deep Security detects malware it triggers an event that appears in the event log. From there you can see information about the event, or create an exception for the file in case of false positives. You can also restore files that are actually benign.

For details, see:

- ["Anti-malware events" on page 1350](#)
- ["View and restore identified malware" on page 856](#)
- ["Configure advanced exploit exceptions" on page 864](#)

SmartScan

Smart Scan uses threat signatures that are stored on Trend Micro servers and provides several benefits:

- Provides fast, cloud-based, real-time security status lookups
- Reduces the time required to deliver protection against emerging threats
- Reduces network bandwidth consumed during pattern updates (bulk of pattern definition updates only need to be delivered to the cloud, not to many computers)
- Reduces cost and overhead of corporate-wide pattern deployments
- Lowers kernel memory consumption on computers (consumption increases minimally over time)

When Smart Scan is enabled, Deep Security first scans locally for security risks. If Deep Security cannot assess the risk of the file during the scan, it will try to connect to a local Smart Scan server. If no local Smart Scan Server is detected, Deep Security will attempt to connect to the Trend Micro Global Smart Scan server. For more information on this feature, see ["Smart Protection in Deep Security" on page 853](#).

Predictive Machine Learning

Deep Security provides enhanced malware protection for unknown threats and zero-day attacks through Predictive Machine Learning. Trend Micro Predictive Machine Learning uses advanced machine learning technology to correlate threat information and perform in-depth file analysis to detect emerging security risks through digital DNA fingerprinting, API mapping, and other file features.

Predictive Machine Learning is effective in protecting against security breaches that result from targeted attacks using techniques such as phishing and spear phishing. In these cases, malware that is designed specifically to target your environment can bypass traditional malware scanning techniques.

During real-time scans, when Deep Security detects an unknown or low-prevalence file, Deep Security scans the file using the Advanced Threat Scan Engine (ATSE) to extract file features. It then sends the report to the Predictive Machine Learning engine on the Trend Micro Smart Protection Network. Through the use of malware modeling, Predictive Machine Learning compares the sample to the malware model, assigns a probability score, and determines the probable malware type that the file contains.

If the file is identified as a threat, Deep Security cleans, quarantines, or deletes the file to prevent the threat from continuing to spread across your network.

For information about using Predictive Machine Learning, see ["Detect emerging threats using Predictive Machine Learning" on page 832](#).

Threat Intelligence

Threat Intelligence (formerly called "Connected Threat Defense") provides enhanced malware protection for new and emerging threats by setting up a connection between Deep Security and Trend Micro's sandboxing technology. For details, see ["Detect emerging threats using Threat Intelligence" on page 833](#).

Malware types

The anti-malware module protects against many file-based threats. See also ["Scan for specific types of malware" on page 810](#) and ["Configure malware handling" on page 820](#)

Virus

Viruses infect files by inserting malicious code. Typically, when an infected file is opened the malicious code automatically runs and delivers a payload in addition to infecting other files.

Below are some of the more common types of viruses:

- **COM and EXE infectors** infect DOS and Windows executable files, which typically have COM and EXE extensions.
- **Macro viruses** infect Microsoft Office files by inserting malicious macros.
- **Boot sector viruses** infect the section of hard disk drives that contain operating system startup instructions

The anti-malware module uses different technologies to identify and clean infected files. The most traditional method is to detect the actual malicious code that is used to infect files and strip infected files of this code. Other methods include regulating changes to infectable files or backing up such files whenever suspicious modifications are applied to them.

Trojans

Some malware does not spread by injecting code into other files. Instead, it has other methods or effects:

- **Trojans:** Malware files that execute and infect the system when opened (like the mythological Trojan horse).
- **Backdoors:** Malicious applications that open port numbers to allow unauthorized remote users to access infected systems.
- **Worms:** Malware programs that use the network to propagate from system to system. Worms are known to propagate by taking advantage of social engineering through attractively packaged email messages, instant messages, or shared files. They are also known to copy themselves to accessible network shares and spread to other computers by exploiting vulnerabilities.
- **Network viruses:** Worms that are memory-only or packet-only programs (not file-based). Anti-malware is unable to detect or remove network viruses.
- **Rootkits:** File-based malware that manipulate calls to operating system components. Applications, including monitoring and security software, need to make such calls for very basic functions, such as listing files or identifying running processes. By manipulating these calls, rootkits are able to hide their presence or the presence of other malware.

Packer

Packers are compressed and encrypted executable programs. To evade detection, malware authors often pack existing malware under several layers of compression and encryption. Anti-malware checks executable files for compression patterns associated with malware.

Spyware/grayware

Spyware and grayware comprises applications and components that collect information to be transmitted to a separate system or collected by another application. Spyware/grayware detections, although exhibiting potentially malicious behavior, may include applications used for legitimate purposes such as remote monitoring. Spyware/grayware applications that are inherently malicious, including those that are distributed through known malware channels, are typically detected as other Trojans.

Spyware and grayware applications are typically categorized as:

- **Spyware:** software installed on a computer to collect and transmit personal information.
- **Dialers:** malicious dialers are designed to connect through premium-rate numbers causing unexpected charges. Some dialers also transmit personal information and download malicious software.
- **Hacking tools:** programs or sets of programs designed to assist unauthorized access to computer systems.
- **Adware (advertising-supported software):** any software package that automatically plays, displays, or downloads advertising material.
- **Cookies:** text files stored by a Web browser. Cookies contain website-related data such as authentication information and site preferences. Cookies are not executable and cannot be infected; however, they can be used as spyware. Even cookies sent from legitimate websites can be used for malicious purposes.
- **Keyloggers:** software that logs user keystrokes to steal passwords and other private information. Some keyloggers transmit logs to remote systems.

What is grayware?

Although they exhibit what can be intrusive behavior, some spyware-like applications are considered legitimate. For example, some commercially available remote control and monitoring applications can track and collect system events and then send information about these events to another system. System administrators and other users may find themselves installing these legitimate applications. These applications are called "grayware".

To provide protection against the illegitimate use of grayware, the anti-malware module detects grayware but provides an option to "approve" detected applications and allow them to run.

Cookie

Cookies are text files stored by a web browser, transmitted back to the web server with each HTTP request. Cookies can contain authentication information, preferences, and (in the case of stored attacks from an infected server) SQL injection and XSS exploits.

Other threats

Other threats includes malware not categorized under any of the malware types. This category includes joke programs, which display false notifications or manipulate screen behavior but are generally harmless.

Possible malware

Possible malware is a file that appears suspicious but cannot be classified as a specific malware variant. When possible malware is detected, Trend Micro recommends that you contact your support provider for assistance in further analysis of the file. By default, these detections are logged and files are sent back to Trend Micro for analysis in a protected manner.

Set up Anti-Malware

Enable and configure anti-malware

To use anti-malware, perform these basic steps:

1. ["Turn on the anti-malware module" on the next page.](#)
2. ["Select the types of scans to perform" on the next page.](#)
3. ["Configure scan exclusions" on the next page](#)
4. ["Ensure that Deep Security can keep up to date on the latest threats" on page 807.](#)

When you have completed these steps, review ["Configure malware scans and exclusions" on page 808](#) and refine the anti-malware scan behavior.

Tip: For most anti-malware settings, you can either configure them for each individual computer or in a policy that applies to multiple computers (for example, to all Windows 2008 Servers). To make management easier, configure the settings in the policy (not individual computers) wherever possible. For more information, see ["Policies, inheritance, and overrides" on page 701.](#)

Tip: CPU usage and RAM usage varies by your anti-malware configuration. To optimize anti-malware performance on Deep Security Agent, see ["Performance tips for anti-malware" on page 825](#).

For an overview of the anti-malware feature, see ["About Anti-Malware" on page 798](#).

Turn on the anti-malware module

1. Go to **Policies**.
2. Double-click the policy for which you want to enable anti-malware.
3. Go to **Anti-Malware > General**.
4. From **Anti-Malware State**, select **On**.
5. Click **Save**.

Select the types of scans to perform

When anti-malware is turned on, Deep Security needs to know what type of scans it should perform (see ["Types of malware scans" on page 799](#)).

1. Go to **Policies**.
2. Double-click the policy to configure.
3. Click **Anti-Malware > General**.
4. Enable or disable each type of scan:
 - a. To perform the scan using default settings, select **Default**.
 - b. To perform the scan using a malware scan configuration that you can customize, select a malware scan configuration.
 - c. To disable the scan, for the malware scan configuration select **No Configuration**.
5. Click **Save**.

Tip: Trend Micro recommends that you configure Deep Security to perform weekly scheduled scans on all protected servers. You can do this using Scheduled Tasks. (See ["Schedule Deep Security to perform tasks" on page 1766](#).)

Configure scan exclusions

To reduce scanning time and minimize the use of computing resources, you can configure Deep Security malware scans to exclude specific folders, files, and file types from all types of scans. You can also exclude process image files from real-time malware scans that are run on Windows servers.

All of these exclusions are specified by selecting exclusion lists on the **Exclusions** tab of the Malware Scan Configuration editor. See "[Specify the files to scan](#)" on page 813.

Tip: If any performance-related issues are experienced when Deep Security anti-malware protection is enabled, you can use exclusions to help troubleshoot these issues by excluding specific folders or files from scanning.

Ensure that Deep Security can keep up to date on the latest threats

To remain effective against new viruses and exploits, Deep Security Agents need to be able to download the latest software and security update packages from Trend Micro or indirectly, from your own Relay. These packages contain threat definitions and patterns. Relay-enabled agents, organized into relay groups (also managed and configured by the Deep Security Manager) retrieve security updates from Trend Micro, and then distribute them to other agents and appliances.

1. Go to **Administration > System Settings > Updates**.
2. Configure Deep Security's ability to retrieve security updates from Trend Micro. Make sure you have at least one relay-enabled agent, and it is assigned to the appropriate agents and appliances.

To determine if a Deep Security Agent is a relay, next to a computer, click **Preview**.

The screenshot displays the Deep Security Manager interface. At the top, a header bar shows the IP address '10.52.116.17', a location 'Location: current physical mac...', the operating system 'Red Hat Enter...', the device type 'Linux Server', and a status 'Managed'. A 'Preview' button is visible next to the IP address. Below this, a detailed view of the agent's configuration is shown. On the left, a list of security features is displayed with their status: Anti-Malware (On, Real Time), Web Reputation (On), Firewall (On, 16 rules), Intrusion Prevention (On, Prevent, 60 rules), Integrity Monitoring (On, 25 rules), Log Inspection (On, 7 rules), and Application Control (On). On the right, a red-bordered box highlights the text 'Relay 92 components available', indicating that the agent is configured as a relay.

3. Go to **Administration > Scheduled Tasks**.
4. Verify that there is a scheduled task to regularly download available updates for both security and software updates.

Configure malware scans and exclusions

Malware scan configurations are reusable saved settings that you can apply when configuring anti-malware in a policy or for a computer. A malware scan configuration specifies what types of malware scanning Deep Security performs and which files it scans. Some policy properties also affect the behavior of malware scans. You can perform the following:

- ["Create or modify a malware scan configuration" below](#)
- ["Scan for specific types of malware" on page 810](#)
- ["Specify the files to scan" on page 813](#)
- ["Specify when real-time scans occur" on page 820](#)
- ["Configure malware handling" on page 820](#)
- ["Identify malware files by file hash digest" on page 823](#)
- ["Configure notifications on the computer" on page 824](#)

The Deep Security [Best Practice Guide](#) also provides several recommendations for configuration of malware scans.

Tip: CPU usage and RAM usage varies by your anti-malware configuration. To optimize anti-malware performance on the Deep Security Agent, see ["Performance tips for anti-malware" on page 825](#).

Create or modify a malware scan configuration

You can create or modify one or more malware scan configurations to control the behavior of a real-time, manual, or scheduled scan. For more information, see ["Malware scan configurations" on page 800](#).

- After you create a malware scan configuration, you can then associate it with a scan in a policy or computer (see ["Select the types of scans to perform" on page 806](#))
- When you edit a malware scan configuration that a policy or computer is using, the changes affect the scans that are associated with the configuration.

Tip: To create a malware scan configuration that is similar to an existing one, duplicate the existing configuration and then edit it.

You can create two types of malware scan configurations according to the type of scan it controls (see "[Types of malware scans](#)" on page 799):

- **Real-time scan configuration:** Controls real-time scans. Some actions such as **Deny Access** are only available to real-time scan configurations
- **Manual/scheduled scan configuration:** Controls either manual or scheduled scans. Some options such as **CPU Usage** are only available to manual/scheduled scan configurations

Deep Security provides a default malware scan configuration for each type of scan. You can use this configuration as follows:

1. Go to **Policies > Common Objects > Other > Malware Scan Configurations**.
2. To create a scan configuration, click **New** and then click **New Real-Time Scan Configuration** or **New Manual/Scheduled Scan Configuration**.
 - a. Type a name to identify the scan configuration. You see the name in a list when configuring malware scans in a policy.
 - b. (Optional) Type a description that explains the use case for the configuration.
3. To view and edit an existing scan configuration, select it and click **Properties**.
4. To duplicate a scan configuration, select it and click **Duplicate**.

To see the policies and computers that are using a malware scan configuration, see the **AssignedTo** tab of the properties.

Test malware scans

Before continuing with further Anti-Malware configuration steps, test real-time and manual/scheduled scans to ensure they're working correctly.

Test real-time scans:

1. Make sure the real-time scan is enabled and that a configuration is selected.
2. Go to the [EICAR site](#) and download their anti-malware test file. This standardized file will test the real-time scan's anti-virus capabilities. The file should be quarantined.
3. On Deep Security Manager, go to **Events & Reports > Anti-Malware Events** to verify the record of the EICAR file detection. If the detection is recorded, the Anti-Malware real-time scans are working correctly.

Test manual/scheduled scans:

Note: Before you begin, make sure the real-time scan is disabled before testing manual/scheduled scans.

1. Go to **Administration**.
2. Click **Scheduled tasks > New**.
3. Select **Scan Computers for Malware** from the drop-down menu and select a frequency. Complete the scan configuration with your desired specifications.
4. Go to the [EICAR site](#) and download their anti-malware test file. This standardized file will test the manual/scheduled scan's anti-virus capabilities.
5. Select the scheduled scan and click **Run Task Now**. The test file should be quarantined.
6. On Deep Security Manager, go to **Events & Reports > Anti-Malware Events** to verify the record of the EICAR file detection. If the detection is recorded, the Anti-Malware manual and scheduled scans are working correctly.

Scan for specific types of malware

- ["Enable Windows AMSI protection \(real-time scans only\)" below](#)
- ["Scan for spyware and grayware" on the next page](#)
- ["Scan for compressed executable files \(real-time scans only\)" on the next page](#)
- ["Scan process memory \(real-time scans only\)" on the next page](#)
- ["Scan compressed files" on page 812](#)
- ["Scan embedded Microsoft Office objects" on page 812](#)

See also:

- ["Enhanced anti-malware and ransomware scanning with behavior monitoring" on page 846](#)
- ["Detect emerging threats using Threat Intelligence" on page 833](#)

Enable Windows AMSI protection (real-time scans only)

The [Windows Antimalware Scan Interface](#) (AMSI) is an interface provided by Microsoft in Windows 10 and newer. Deep Security leverages AMSI to help detect malicious scripts. By default, this option is enabled in Deep Security malware scan configurations.

1. Open the properties of the malware scan configuration.
2. On the **General** tab, select **Enable AMSI protection**.
3. Click **OK**.

Scan for spyware and grayware

When spyware and grayware protection is enabled, the spyware scan engine quarantines suspicious files when they are detected.

1. Open the properties of the malware scan configuration.
2. On the **General** tab, select **Enable spyware/grayware protection**.
3. Click **OK**.

To identify a file that the spyware scan engine should ignore, see "[Configure advanced exploit exceptions](#)" on page 864.

Scan for compressed executable files (real-time scans only)

Viruses often use real-time compression algorithms to attempt to circumvent virus filtering. The IntelliTrap feature blocks real-time compressed executable files and pairing them with other malware characteristics.

Note: Because IntelliTrap identifies such files as security risks and may incorrectly block safe files, consider quarantining (not deleting or cleaning) files when you enable IntelliTrap. (See "[Configure malware handling](#)" on page 820.) If users regularly exchange real-time compressed executable files, disable IntelliTrap. IntelliTrap uses the virus scan engine, IntelliTrap Pattern, and IntelliTrap Exception Pattern.

1. Open the properties of the malware scan configuration.
2. On the **General** tab, select **Enable IntelliTrap**.
3. Click **OK**.

Scan process memory (real-time scans only)

Monitor process memory in real time and perform additional checks with the Trend Micro Smart Protection network to determine whether a suspicious process is known to be malicious. If the process is malicious, Deep Security terminates the process. For more information, see "[Smart Protection in Deep Security](#)" on page 853

1. Open the properties of the malware scan configuration.
2. On the **General** tab, select **Scan process memory for malware**.
3. Click **OK**.

Scan compressed files

Extract compressed files and scan the contents for malware. When you enable the scan, you specify the maximum size and number of files to extract (large files can affect performance). You also specify the levels of compression to inspect so that you can scan compressed files that reside inside compressed files. Level 1 compression is a single compressed file. Compressed files inside that file are level two. You can scan a maximum of 6 compression levels, however higher levels can affect performance.

1. Open the properties of the malware scan configuration.
2. On the **Advanced** tab, select **Scan compressed files**.
3. Specify the maximum size of content files to extract, in MB, the levels of compression to scan, and the maximum number of files to extract.
4. Click **OK**.

Scan embedded Microsoft Office objects

Certain versions of Microsoft Office use Object Linking and Embedding (OLE) to insert files and other objects into Office files. These embedded objects can contain malicious code.

Specify the number of OLE layers to scan to detect objects that are embedded in other objects. To reduce the impact on performance, you can scan only a few layers of embedded objects within each file.

1. Open the properties of the malware scan configuration.
2. On the **Advanced** tab, select **Scan Embedded Microsoft Office Objects**.
3. Specify the number of OLE layers to scan.
4. Click **OK**.

Enable a manual scan for the notifier application on Windows OS

Enabling a manual scan through the [Trend Micro notifier application](#) is supported for Deep Security Agents 20.0.0-7476 and later.

This scan is disabled by default. You can enable and trigger it as follows:

1. From the **Computer** or **Policy** editor, select **Anti-Malware > General**.
2. Under **Manual Scan**, select **Allow the agent to trigger or cancel a manual scan**.

Note that agentless scans are not supported.

Enable a manual scan on Linux OS

Enabling a manual scan is supported for Deep Security Agents 20.0.0-7476 and later.

This scan is disabled by default. You can enable it as follows:

1. From the **Computer** or **Policy** editor, select **Anti-Malware > General**.
2. Under **Manual Scan**, select **Allow the agent to trigger or cancel a manual scan**.

Note that agentless scans are not supported.

Specify the files to scan

Identify files and directories to include in the scan and then identify any exclusions from those files and directories. You can also scan network directories.

- ["Inclusions" below](#)
- ["Exclusions" on the next page](#)
- ["Scan a network directory \(real-time scan only\)" on page 820](#)

Inclusions

Specify the directories to scan as well as the files inside the directories to scan.

To identify directories to scan, you can specify all directories or a list of directories. The directory list uses patterns with a specific syntax to identify the directories to scan. (See ["Syntax for directory lists" on page 816](#).)

To identify the files to scan, use one of the following options:

- All files
- File types that are identified by IntelliScan. IntelliScan only scans file types that are vulnerable to infection, such as .zip or .exe. IntelliScan does not rely on file extensions to determine file type but instead reads the header and content of a file to determine whether it should be scanned. Compared to scanning all files, Intelliscan reduces the number of files to scan and improves performance.
- Files that have a file name extension that is included in a specified list: The file extension list uses patterns with a specific syntax. (See ["Syntax of file extension lists" on page 819](#).)

1. Open the properties of the malware scan configuration.
2. Click the **Inclusions** tab.

3. To specify the directories to scan, select **All directories** or **Directory List**.
4. If you selected **Directory List**, from the drop-down menu either select an existing list or select **New** to create one.
5. To specify the files to scan, select either **All files**, **File types scanned by IntelliScan**, or **File Extension List**.
6. If you selected **File Extension List**, from the drop-down menu either select an existing list or select **New** to create one.
7. Click **OK**.

Exclusions

Exclude directories, files, and file extensions from being scanned. For real-time scans (except when performed by Deep Security Virtual Appliance), you can also exclude process image files from being scanned.

Examples of files and folders to exclude:

- If you are creating a malware scan configuration for a Microsoft Exchange server, you should exclude the SMEX quarantine folder to avoid re-scanning files that have already been confirmed to be malware.
- If you choose to run malware scans on database servers used by Deep Security Manager, exclude the data directory. The Deep Security Manager captures and stores intrusion prevention data that might include viruses, which can trigger a quarantine by the Deep Security Agent, leading to database corruption.
- If you have large VMware images, exclude the directory containing these images if you experience performance issues.

Tip: You can also exclude files from Anti-Malware scanning when they are signed by a trusted digital certificate. This type of exclusion is defined in policy or computer settings. (See ["Exclude files signed by a trusted certificate" on page 870.](#))

Exclude directories, files, and process image files by creating a list of patterns to exclude

1. Open the properties of the malware scan configuration.
2. Click the **Exclusions** tab.

3. Specify the directories to exclude:
 - a. Select **Directory List**.
 - b. Select a directory list or select **New** to create one. (See ["Syntax for directory lists" on the next page.](#))
 - c. If you created a directory list, select it in the directory list.
4. Similarly, specify the file list, file extension list, and process image file list to exclude. (See ["Syntax of file lists" on page 817](#), ["Syntax of file extension lists" on page 819](#), and ["Syntax of process image file lists \(real-time scans only\)" on page 820.](#))
5. Click **OK**.

Note:

When Deep Security Agent cannot determine the type of a target file, the Anti-Malware scan engine loads the file to memory to identify if it was a self-extracting file. If many large files are loaded to memory, it can affect scan engine performance. To exclude files over a specific size, you can use the following Deep Security Manager command:

```
dsm_c -action changesetting -name  
com.trendmicro.ds.antimalware:settings.configuration.maxSelfExtractRTScan  
SizeMB -value 512
```

In the example above, the file-size limitation is set to 512MB for loading target files. The scan engine will not add files larger than the set value to memory and will instead scan them directly. Note that in order to deploy this setting, you need to send the policy to your target Deep Security Agent after running the command in Deep Security Manager.

Test file exclusions

Before continuing with further Anti-Malware configuration steps, test file exclusions to ensure they're working correctly:

Note: Before you begin, make sure the real-time scan is enabled and a configuration is selected.

1. Go to **Policies > Common Objects > Other > Malware Scan Configurations**.
2. Click **New > New Real-time Scan Configuration**.
3. Go to the **Exclusions** tab, and select **New** from the directory list.
4. Name the directory list.
5. Under **Directory(s)** specify the path of the directory you want to exclude from the scan. For example, `c:\Test Folder\`. Click **OK**.
6. Go to the **General** tab, name the manual scan, and click **OK**.

- Go to the [EICAR site](#) and download their anti-malware test file. Save the file in the folder specified in the previous step. The file should be saved and undetected by the Anti-Malware module.

Syntax for directory lists

Note: Directory list items accept either forward slash "/" or backslash "\" to support both Windows and Linux conventions.

Exclusion	Format	Description	Examples
Directory	DIRECTORY\	Excludes all files in the specified directory and all files in all subdirectories.	C:\Program Files\ Excludes all files in the "Program Files" directory and all subdirectories.
Directory with wildcard (*)	DIRECTORY*\	Excludes all subdirectories except for the specified subdirectory and the files that it contains.	C:\abc* Excludes all files in all subdirectories of "abc" but does not exclude the files in the "abc" directory. C:\abc\wx*z\ <i>Matches:</i> C:\abc\wxz\ C:\abc\wx123z\ <i>Does not match:</i> C:\abc\wx C:\abc\wx123z C:\abc*wx\ <i>Matches:</i> C:\abc\wx\ C:\abc\123wx\ <i>Does not match:</i> C:\abc\wx C:\abc\123wx
Directory with wildcard (*)	DIRECTORY*\	Excludes any subdirectories with a matching name, but does not exclude the files in that directory and any subdirectories.	C:\Program Files\SubDirName* Excludes any subdirectories with a folder name that begins with "SubDirName". Does not exclude all files under C:\Program Files\ or any

Exclusion	Format	Description	Examples
			other subdirectories.
Environment variable	<code>\${ENV VAR}</code>	Excludes all files and subdirectories defined by an environment variable. For a Virtual Appliance, the value pairs for the environment variable must be defined in Policy or Computer Editor > Settings > General > Environment Variable Overrides .	<code>\${windir}</code> If the variable resolves to "c:\windows", excludes all the files in "c:\windows" and all its subdirectories.
Comments	<code>DIRECTORY #Comment</code>	Adds a comment to your exclusion definitions.	<code>c:\abc #Exclude the abc directory</code>

Syntax of file lists

Exclusion	Format	Description	Example
File	FILE	Excludes all files with the specified file name regardless of its location or directory.	<code>abc.doc</code> Excludes all files named "abc.doc" in all directories. Does not exclude "abc.exe".
File path	FILEPATH	Excludes the single file specified by the file path.	<code>C:\Documents\abc.doc</code> Excludes only the file named "abc.doc" in the "Documents" directory.
File path with wildcard (*)	FILEPATH	Excludes all the files specified by the file path.	<code>C:\Documents\abc.co*</code> (For Windows Agent platforms only) Excludes any file that has file name of "abc" and extension beginning with ".co" in the "Documents" directory.
Filename is a wildcard (*)	FILEPATH*	Excludes all files under the path, but does not include the files in unspecified subdirectories	<code>C:\Documents*</code> Excludes all files under the directory C:\Documents\ <code>C:\Documents\SubDirName*</code> Excludes all files within subdirectories with a folder name that begins with "SubDirName". Does not exclude all files under C:\Documents\ or any other subdirectories.

Exclusion	Format	Description	Example
			<p>C:\Documents** Excludes all files within all direct subdirectories under C:\Documents. Does not exclude files in subsequent subdirectories.</p>
File with wildcard (*)	FILE*	Excludes all files with a matching pattern in the file name.	<p>abc*.exe Excludes any file that has prefix of "abc" and extension of ".exe".</p> <p>*.db <i>Matches:</i> 123.db abc.db <i>Does not match:</i> 123db 123.abd cbc.dba</p> <p>*db <i>Matches:</i> 123.db 123db ac.db acdb db <i>Does not match:</i> db123</p> <p>wxy*.db <i>Matches:</i> wxy.db wxy123.db <i>Does not match:</i> wxydb</p>
File with wildcard (*)	FILE.EXT*	Excludes all files with a matching pattern in the file extension.	<p>abc.v* Excludes any file that has file name of "abc" and extension beginning with ".v".</p> <p>abc.*pp <i>Matches:</i> abc.pp abc.app <i>Does not match:</i> wxy.app</p>

Exclusion	Format	Description	Example
			<p>abc.a*p Matches: abc.ap abc.a123p Does not match: abc.pp</p> <p>abc.* Matches: abc.123 abc.xyz Does not match: wxy.123</p>
File with wildcard (*)	FILE*.EXT*	Excludes all files with a matching pattern in the file name and in the extension.	<p>a*c.a*p Matches: ac.ap a123c.ap ac.a456p a123c.a456p Does not match: ad.aa</p>
Environment variable	\${ENV VAR}	Excludes files specified by an environment variable with the format \${ENV VAR}. These can be defined or overridden using Policy or Computer Editor > Settings > General > Environment Variable Overrides .	<p>\${myDBFile} Excludes the file "myDBFile".</p>
Comments	FILEPATH #Comment	Adds a comment to your exclusion definitions.	<p>C:\Documents\abc.doc #This is a comment</p>

Syntax of file extension lists

Exclusion	Format	Description	Example
File Extension	EXT	Matches all files with a matching file extension.	<p>doc Matches all files with a ".doc" extension in all directories.</p>
Comments	EXT #Comment	Adds a comment to your exclusion definitions.	<p>doc #This a comment</p>

Syntax of process image file lists (real-time scans only)

Exclusion	Format	Description	Example
File path	FILEPATH	Excludes the Process Image file specified by the file path.	<i>C:\abc\file.exe</i> Excludes only the file named "file.exe" in the "abc" directory.

Scan a network directory (real-time scan only)

If you want to scan files and folders in network shares and mapped network drives that reside in a Network File System (NFS), Server Message Block (SMB) or Common Internet File System (CIFS), select **Enable Network Directory Scan**. This option is available only for real-time scans.

Note: Resources accessed in "*~/gvfs*" via GVFS, a virtual file system available for the GNOME desktop, will be treated as local resources, not network drives.

Note: If a virus is detected when scanning a network folder on Windows, the agent may display some "clean failed" (delete failed) events.

Specify when real-time scans occur

Choose between scanning files when they are opened for reading, when they are written to, or both.

1. Open the properties of the malware scan configuration.
2. On the **Advanced** tab, select one of the options for the **Real-Time Scan** property.
3. Click **OK**.

Configure malware handling

Configure how Deep Security behaves when malware is detected:

- ["Customize malware remedial actions" on the next page](#)
- ["Generate alerts for malware detection" on page 823](#)
- ["Apply NSX security tags" on page 823](#)

Customize malware remedial actions

When Deep Security detects malware, it performs a remedial action to handle the file. There are five possible actions that Deep Security can take when it encounters malware:

- **Pass:** Allows full access to the infected file without doing anything to the file. (An Anti-Malware Event is still recorded.)

Note: The remedial action **Pass** should never be used for a possible virus.

- **Clean:** Cleans an infected file before allowing full access to it. If the file can't be cleaned, it is quarantined.
- **Delete:** On Linux, the infected file is deleted without a backup. On Windows, the infected file is backed up and then deleted. Windows backup files can be [viewed and restored](#) in **Events & Reports > Events > Anti-Malware Events > Identified Files**.
- **Deny Access:** This scan action can only be performed during Real-time scans. When Deep Security detects an attempt to open or execute an infected file, it immediately blocks the operation. The infected file is left unchanged. When the Access Denied action is triggered, the infected files stay in their original location.

Note: Do not use the remedial action **Deny Access** when **Real-Time Scan** is set to **During Write**. When **During Write** is selected, files are scanned when they are written and the action **Deny Access** has no effect.

- **Quarantine:** Moves the infected file to the quarantine directory on the computer or Virtual Appliance. The quarantined file can be [viewed and restored](#) in **Events & Reports > Events > Anti-Malware Events > Identified Files**.

Note: Malware marked as **Quarantined** on Linux might be marked as **Deleted** on Windows, despite the malware being identical on both operating systems. In either case, the file can be [viewed and restored](#) in **Events & Reports > Events > Anti-Malware Events > Identified Files**.

Note: On Windows, infected non-compressed files (for example, .txt files) are quarantined, while infected compressed files (for example, .zip files) are deleted. On Windows, both quarantined or deleted files have a backup that can be [viewed and restored](#) in **Events & Reports > Events > Anti-Malware Events > Identified Files**. On Linux, all infected files (compressed or non-compressed) are quarantined, and can be

[viewed and restored](#) in **Events & Reports > Events > Anti-Malware Events > Identified Files**.

The default remediation actions in the malware scan configurations are appropriate for most circumstances. However, you can customize the actions to take when Deep Security detects malware. You can either use the action that ActiveAction determines, or specify the action for each type of vulnerability.

ActiveAction is a predefined group of cleanup actions that are optimized for each malware category. Trend Micro continually adjusts the actions in ActiveAction to ensure that individual detections are handled properly. (See "[ActiveAction actions](#)" below.)

1. Open the properties of the malware scan configuration.
2. On the **Advanced** tab, for **Remediation Actions** select Custom.
3. Specify the action to take:
 - a. To let ActiveAction decide which action to take, select **Use action recommended by ActiveAction**.
 - b. To specify an action for each type of vulnerability, select **Use custom actions**, and then select the actions to use.
4. Specify the action to take for Possible Malware.
5. Click **OK**.

ActiveAction actions

The following table lists the actions that ActiveAction takes:

Malware Type	Action
"Virus" on page 802	Clean . If a virus cannot be cleaned, it is deleted (Windows) or quarantined (Linux or Solaris). There is an exception to this behavior: On a Linux or Solaris agent, if a virus of type 'Test Virus' is found, access is denied to the infected file.
"Trojans" on page 803	Quarantine
"Packer" on page 803	Quarantine
"Spyware/grayware" on page 804	Quarantine
CVE Exploit	Quarantine
Aggressive Detection Rule	Pass (This setting detects more issues but may also result in more false positives, so the default action is to raise an event.)

Malware Type	Action
"Cookie" on page 805	Delete (Does not apply to real-time scans)
"Other threats" on page 805	Clean If a threat cannot be cleaned, it is handled as follows: <ul style="list-style-type: none"> on Windows, the infected file is deleted but can be viewed and restored, if needed on Linux or Solaris, access is denied to the infected file Also, on a Linux or Solaris agent, if a virus of type 'Joke' is found, it is quarantined immediately. No attempt is made to clean it.
"Possible malware" on page 805	ActiveAction

Note: When the agent downloads virus pattern updates from an ActiveUpdate server or relay, it may change its ActiveAction scan actions.

For information about CVE Exploit and Aggressive Detection Rule, see ["Create a malware scan configuration for use with Threat Intelligence" on page 840](#).

Generate alerts for malware detection

When Deep Security detects malware, you can generate an alert.

1. Open the properties of the malware scan configuration.
2. On the **General** tab, for **Alert** select **Alert when this Malware Scan Configuration logs an event**.
3. Click **OK**.

Apply NSX security tags

Deep Security can apply **NSX Security Tags** to protected VMs upon detecting a malware threat. For details, see ["Configure Anti-Malware to apply NSX security tags" on page 624](#).

Identify malware files by file hash digest

Deep Security can calculate the hash value of a malware file and display it on the **Events & Reports > Events > Anti-Malware Events** page. Because a particular piece of malware can go

by several different names, the hash value is useful because it uniquely identifies the malware. You can use the hash value when looking up information about the malware from other sources.

1. Open the policy or computer editor that you want to configure.
2. Click **Anti-Malware > Advanced**.
3. Under **File Hash Calculation**, clear the **Default** or **Inherited** check box. (**Default** is displayed for a root policy and **Inherited** is displayed for child policies).

Note: When **Inherited** is selected, the file hash settings are inherited from the current policy's parent policy.

Note: When **Default** is selected, Deep Security does not calculate any hash values.

4. Select the **Calculate hash values of all anti-malware events**.
5. By default, Deep Security will produce SHA-1 hash values. If you want to produce additional hash values, you can select one or both of **MD5** and **SHA256**.
6. You can also change the maximum size of malware files that will have hash values calculated. The default is to skip files that are larger than 128MB, but you can change the value to anything between 64 and 512 MB.

Configure notifications on the computer

On Windows-based agents, you might occasionally see onscreen notification messages alerting you of Deep Security actions you must take that are related to the anti-malware and web reputation modules. For example, you might see the message, `A reboot is required for Anti-Malware cleanup task`. You must click OK on the dialog box to dismiss it.

If you do not want these notifications to appear:

1. Go to the **Computer or Policy editor**¹.
2. Click **Settings** on the left.
3. Under the **General** tab, scroll to the **Notifications** section.
4. Set **Suppress all pop-up notifications on host** to **Yes**. The messages still appear as alerts or events in Deep Security Manager. For more information about the notifier, see "**Deep Security notifier**" on page 1478.

¹You can change these settings for a policy or for a specific computer. To change the settings for a policy, go to the Policies page and double-click the policy that you want to edit (or select the policy and click Details). To change the settings for a computer, go to the Computers page and double-click the computer that you want to edit (or select the computer and click Details).

Performance tips for anti-malware

To improve system resources utilization on Deep Security Agent, you can optimize these performance-related settings according to best practices.

See also:

- ["Configure advanced exploit exceptions" on page 864](#)
- ["Identify malware files by file hash digest" on page 823](#)
- ["Configure NSX security tags" on page 624](#)

Minimize disk usage

Reserve an appropriate amount of disk space for storing identified malware files. The space that you reserve applies globally to all computers: physical machines, virtual machines, and Deep Security Virtual Appliances. The setting can be overridden at the policy level and at the computer level.

Tip: Alerts are raised when there is not enough disk space to store an identified file.

1. Open the policy or computer editor that you want to configure.
2. Click **Anti-Malware > Advanced**.
3. Under **Identified Files**, clear **Default**.
4. Specify the disk space to use in the **Maximum disk space used to store identified files** box.
5. Click **Save**.

If you are using a Deep Security Virtual Appliance to protect virtual machines, all identified files from the protected VMs will be stored on the virtual appliance. As a result, you should increase the amount of disk space for identified files on the virtual appliance.

See also ["Virtual Appliance Scan Caching" on page 1035](#)

Optimize CPU usage

- Exclude files from real-time scans if they are normally safe but have high I/O, such as databases, Microsoft Exchange quarantines, and network shares (on Windows, you can use [procmon](#) to find files with high I/O). See ["Exclusions" on page 814](#).
- Do not scan network directories. See ["Scan a network directory \(real-time scan only\)" on page 820](#)

- Do not use Smart Scan if the computer doesn't have reliable network connectivity to the Trend Micro Smart Protection Network or your Smart Protection Server. See ["Smart Protection in Deep Security" on page 853](#).
- Reduce the CPU impact of malware scans by setting CPU Usage to **Medium** (Recommended; pauses between scanning files) or **Low** (pauses between scanning files for a longer interval than the medium setting).
 - a. Open the properties of the malware scan configuration.
 - b. On the **Advanced** tab, select the **CPU Usage** during which scans run.
 - c. Click **OK**.
- Create a scheduled task to run scans at a time when CPU resources are more readily available. See ["Schedule Deep Security to perform tasks" on page 1766](#).
- In VM Scan Cache, select a Real-Time Scan Cache Configuration. If scans are not frequent, increase the Expiry Time (avoid repeated scans). See ["Virtual Appliance Scan Caching" on page 1035](#).
- Use agentless deployments so that CPU usage is in one centralized virtual appliance, not on every computer. See ["Choose agentless vs. combined mode protection" on page 548](#)
- Reduce or keep small default values for the maximum file size to scan, maximum levels of compression from which to extract files, maximum size of individual extracted files, maximum number of files to extract, and OLE Layers to scan. See ["Scan for specific types of malware" on page 810](#).

Warning: Most malware is small, and nested compression indicates malware. But if you don't scan large files, there is a small risk that anti-malware won't detect some malware. You can mitigate this risk with other features such as integrity monitoring. See

• **Enable multi-threaded processing**

Use multi-threaded processing for manual and scheduled scans (by default, real-time scans use multi-threaded processing). Multi-threaded processing is effective only on systems that support this capability. To apply the setting, enable it and then restart the computer.

Note: Do not enable multi-threaded processing if:

- Resources are limited (for example, CPU-bound tasks)
- Resources must be held by only one operator at a time (for example, IO-bound tasks)

- a. Go to **Policies**.
- b. Double-click to open the policy where you want to enable multi-threaded processing.
- c. Go to **Anti-Malware > Advanced**.
- d. In the **Resource Allocation for Malware Scans** section, select **Yes**.
- e. Restart the computers on which you enabled multi-threaded processing for the setting to take effect.

Note: Enabling multi-threaded processing may impact CPU usage:

- Multi-threaded processing can reduce the number of CPU cores available at a given time to the computer's other processes.
- On Linux, when **Resource Allocation for Malware Scans** is enabled, the CPU usage setting is ignored even if set to **Medium** or **Low**.

Optimize RAM usage

- Reduce or keep small default values for the maximum file size to scan, maximum levels of compression from which to extract files, maximum size of individual extracted files, maximum number of files to extract, and OLE Layers to scan. See ["Scan for specific types of malware" on page 810](#).

Warning: Most malware is small, and nested compression indicates malware. But if you don't scan large files, there is a small risk that anti-malware won't detect some malware. You can mitigate this risk with other features such as integrity monitoring. See ["Set up Integrity Monitoring" on page 977](#)

- Use agentless deployments (RAM usage is in one centralized virtual appliance, not every computer). See ["Choose agentless vs. combined mode protection" on page 548](#).

Coexistence of Deep Security Agent with Microsoft Defender Antivirus

Microsoft Defender Antivirus is automatically installed on Microsoft Windows Server 2016 and later, as well as Windows 10 and later. Deep Security Agent (DSA) can coexist with Microsoft Defender Antivirus in its passive mode, including when Tamper Protection mode is activated

and Microsoft Defender Antivirus stays in passive mode, for all operating system levels protected by Trend Micro Deep Security.

Microsoft Defender Antivirus application files for exclusion list for DSA

If Microsoft Defender Antivirus cannot switch to passive mode, you must add Microsoft Defender Antivirus for Endpoint to the exclusion list for DSA. For more information, see [Make the switch from non-Microsoft endpoint protection to Microsoft Defender Antivirus for Endpoint](#).

The following are locations of Microsoft Defender Antivirus executable files:

- `%Program Files%\Windows Defender\`
- `%ProgramData%\Microsoft\Windows Defender\Platform\4.18.2201.10-0*\`

DSA folders and processes for Microsoft Defender Antivirus exclusion list

You need to add Deep Security agent folders and processes to your [Microsoft Defender Antivirus exclusion list](#).

Folder:

- `C:\Program Files\Trend Micro\AMSP`
- `C:\Program Files\Trend Micro\Deep Security Agent`

Process:

- `C:\Program Files\Trend Micro\AMSP\coreServiceShell.exe`
- `C:\Program Files\Trend Micro\AMSP\coreFrameworkHost.exe`
- `C:\Program Files\Trend Micro\Deep Security Agent\dsa.exe`
- `C:\Program Files\Trend Micro\Deep Security Agent\Notifier.exe`

Tamper protection

Activating tamper protection of Microsoft Defender Antivirus safeguards against diverting this particular antivirus to passive mode. If multiple antivirus products have been deployed, it would be reasonable to retain only one antimalware component of one antivirus product.

For details on the supported environments, see [Microsoft Defender Antivirus compatibility with other security products](#).

Virtual Appliance Scan Caching

Scan Caching is used by the Virtual Appliance to maximize the efficiency of Anti-Malware and Integrity Monitoring Scans of virtual machines. Scan Caching improves the efficiency of scans by eliminating the unnecessary scanning of identical content across multiple VMs in large VMware deployments. A Scan Cache contains lists of files and other scan targets that have been scanned by a Deep Security protection module. If a scan target on a virtual machine is determined to be identical to a target that has already been scanned, the Virtual Appliance will not scan the target a second time. Attributes used to determine whether entities are identical are creation time, modification time, file size, and file name. In the case of Real-time Scan Caching, Deep Security will read partial content of files to determine if two files are identical. There is an option setting to use a file's Update Sequence Number (USN, Windows only) but its use should be limited to cloned virtual machines.

Scan Caching benefits **Integrity Monitoring** by sharing Integrity Monitoring scan results among cloned or similar virtual machines.

Scan Caching benefits **Manual Malware Scans** of cloned or similar virtual machines by increasing the speed up subsequent scans.

Scan Caching benefits **Real-Time Malware Scanning** by speeding up boot process scans and application access scans on cloned or similar virtual machines.

Scan Cache Configurations

A Scan Cache Configuration is a collection of settings that determines Expiry Time, the use of Update Sequence Numbers (USNs), files to exclude, and files to include.

Note: Virtual machines that use the same Scan Cache Configuration also share the same Scan Cache.

You can see the list of existing Scan Cache Configurations by going **Administration > System Settings > Advanced > Scan Cache Configurations** and clicking **View Scan Cache Configurations**. Deep Security comes with several preconfigured default Scan Cache Configurations. These are implemented automatically by the Virtual Appliance depending the properties of the virtual machines being protected and the types of scan being performed.

Expiry Time determines the lifetime of individual entries in a Scan Cache. The default recommended settings are one day for Manual (on-demand) or Scheduled Malware Scans, 15 mins for Real-Time Malware Scans, and one day for Integrity Monitoring Scans.

Use USN (Windows only) specifies whether to make use of Windows NTFS Update Sequence Numbers, which is a 64-bit number used to record changes to an individual file. This option should only be set for cloned VMs.

Files Included and **Files Excluded** are regular expression patterns and lists of files to be included in or excluded from the Scan Cache. Files to be scanned are matched against the include list first.

Individual files and folders can be identified by name or you can use wildcards ("*" and "?") to refer to multiple files and locations with a single expression. (Use "*" to represent any zero or more characters, and use question mark "?" to represent any single character.)

Note: The include and exclude lists only determine whether the scan of the file will take advantage of Scan Caching. The lists will not prevent a file from being scanned in the traditional way.

Malware Scan Cache Configuration

To select which Scan Cache Configuration is used by a virtual machine, open the **Computer or Policy editor**¹ and go to **Anti-Malware > Advanced > VM Scan Cache**. You can select which Scan Cache Configuration is used for Real-Time Malware Scans and which Scan Cache Configuration is used for manual and scheduled scans.

Integrity Monitoring Scan Cache Configuration

To select which Scan Cache Configuration is used by a virtual machine, open the **Computer or Policy editor**² and go to **Integrity Monitoring > Advanced > VM Scan Cache**.

Scan Cache Settings

Scan Cache Settings are not included in a Scan Cache Configuration because they determine how the Virtual Appliance manages Scan Caches rather than how Scan Caching is carried out. Scan Cache settings are controlled at the Policy level. You can find the Scan cache settings by opening a **Policy editor**³ and going to the **Settings > General > Virtual Appliance Scans** area.

¹You can change these settings for a policy or for a specific computer. To change the settings for a policy, go to the Policies page and double-click the policy that you want to edit (or select the policy and click Details). To change the settings for a computer, go to the Computers page and double-click the computer that you want to edit (or select the computer and click Details).

²You can change these settings for a policy or for a specific computer. To change the settings for a policy, go to the Policies page and double-click the policy that you want to edit (or select the policy and click Details). To change the settings for a computer, go to the Computers page and double-click the computer that you want to edit (or select the computer and click Details).

³To open the Policy editor, go to the Policies page and double-click the policy that you want to edit (or select the policy and click Details).

Max Concurrent Scans determines the number of scans that the Virtual Appliance performs at the same time. The recommended number is five. If you increase this number beyond 10, scan performance may degrade. Scan requests are queued by the virtual appliance and carried out in the order in which they arrive. This setting applies to manual and scheduled scans.

Max On-Demand Malware Scan Cache Entries determines, for manual or scheduled malware scans, the maximum number of records that identify and describe a file or other type of scannable content to keep. One million entries use approximately 100 MB of memory.

Max Malware Real-Time Scan Cache Entries determines, for real-time malware scans, the maximum number of records that identify and describe a file or other type of scannable content to keep. One million entries use approximately 100MB of memory.

Max Integrity Monitoring Scan Cache Entries determines the maximum number of entities included in the baseline data for integrity monitoring. Two hundred thousand entities use approximately 100MB of memory.

When to change the default configuration

Scan caching is designed to avoid scanning identical files twice. Deep Security does not examine the entire contents of all files to determine if files are identical. Although when configured to do so, Deep Security can check the USN value of a file, and during Real-time Scans it will read partial content of files, it generally examines file attributes to determine if files are identical. It would be difficult but not impossible for some malware to make changes to a file and then restore those files attributes to what they were before the file was modified.

Deep Security limits this potential vulnerability by establishing short default cache expiry times. To strengthen the security you can use shorter expiry times on cache and you can use USN but doing so may reduce the performance benefit or require a larger cache setting. For the strongest security for VMs that you want to keep separate and never share scan results you can create dedicated policies for these VMs kind of like keeping them in separate zones. This might be appropriate if you have different departments or organizations sharing the same infrastructure. (In a multi-tenant Deep Security Manager, this is automatically enforced for each tenant.)

If you have a very large number of guest VMs per ESXi host (for example, a VDI environment), then you should monitor your disk I/O and CPU usage during scanning. If scanning takes too long, then you may need to increase the size of the cache or adjust the Scan Cache Settings until you get better performance. If you need to increase cache size, then you may need to adjust Deep Security Virtual Appliance system memory too.

Detect emerging threats using Predictive Machine Learning

Note: Predictive Machine Learning is supported with Deep Security Agent 11.0 +. For details on which platforms support this feature, see ["Supported features by platform" on page 360](#).

Use Predictive Machine Learning to detect unknown or low-prevalence malware. (For more information, see ["Predictive Machine Learning" on page 802](#).)

Predictive Machine Learning uses the Advanced Threat Scan Engine (ATSE) to extract file features and sends the report to the Predictive Machine Learning engine on the Trend Micro Smart Protection Network. To enable Predictive Machine Learning, perform the following:

1. ["Ensure Internet connectivity" below](#)
2. ["Enable Predictive Machine Learning" below](#)

As with all detected malware, Predictive Machine Learning logs an event when it detects malware. (See ["About Deep Security event logging" on page 1125](#).) You can also create an exception for any false positives. (See ["Configure advanced exploit exceptions" on page 864](#).)

Ensure Internet connectivity

Predictive Machine Learning requires access to the Global Census Service, Good File Reputation Service, and Predictive Machine Learning Service. These services are hosted in the Trend Micro Smart Protection Network. If your Deep Security Agents or Virtual Appliance cannot access the Internet directly, see ["Configure agents that have no internet access" on page 1453](#) for workarounds.

Enable Predictive Machine Learning

Predictive Machine Learning is configured as part of a real-time scan configuration that is applied to a policy or individual computer. (See ["Configure malware scans and exclusions" on page 808](#).) After you configure the scan configuration, apply it to a policy or computer.

Note: Predictive Machine Learning protects only the files and directories that real-time scan is configured to scan. See ["Specify the files to scan" on page 813](#).

These settings can only be applied to real-time scan configurations.

1. Go to **Policies > Common Objects > Other > Malware Scan Configurations**.
2. Select the real-time scan configuration to configure and click **Details**.

You can also create a new real-time scan configuration if desired.

3. On the **General** tab, under **Predictive Machine Learning**, select **Enable Predictive Machine Learning**. In the **Action to take** list, choose the remediation action that you want Deep Security to take when it detects malware:
 - **Quarantine (recommended)**: Moves the infected file to the quarantine directory on the protected computer. The quarantined file can be viewed and restored in **Events & Reports > Events > Anti-Malware Events > Identified Files**.
 - **Pass**: Allows full access to the infected file without doing anything to the file. (An Anti-Malware Event is still recorded.)
 - **Delete**: On Linux, the infected file is deleted without a backup. On Windows, the infected file is backed up and then deleted. Windows backup files can be viewed and restored in **Events & Reports > Events > Anti-Malware Events > Identified Files**.
4. Click **OK**.
5. Open the policy or computer editor to which you want to apply the scan configuration and go to **Anti-Malware > General**.
6. Ensure that **Anti-Malware State** is **On** or **Inherited (On)**.
7. In the **Real-Time Scan** section, select the malware scan configuration.
8. Click **Save**.

Detect emerging threats using Threat Intelligence

Tip: The Threat Intelligence feature was formerly called Connected Threat Defense. If you were previously using Connected Threat Defense, see ["Migrating from Connected Threat Defense to Threat Intelligence" on page 844](#).

In the modern data center, more and more security breaches are a result of targeted attacks using techniques such as phishing and spear-phishing. In these cases, malware writers can bypass traditional malware scanners by creating malware specifically targeted for your environment. Deep Security provides enhanced malware protection for new and emerging threats through its Threat Intelligence feature.

Note: Threat Intelligence is not available when FIPS mode is enabled. See ["FIPS 140 support" on page 1811](#).

In this article:

- ["How does Threat Intelligence work?"](#) below
- ["Check the Threat Intelligence prerequisites"](#) on the next page
- ["Set up a connection to Trend Micro Vision One"](#) on the next page
- ["Set up a connection to Deep Discovery Analyzer"](#) on page 836
- ["Set up a connection to Trend Micro Apex Central"](#) on page 838
- ["Create a malware scan configuration for use with Threat Intelligence"](#) on page 840
- ["Enable Threat Intelligence for your computers"](#) on page 841
- ["Manually submit a file to Sandbox Analysis"](#) on page 841
- ["Allow a file that has raised a false alarm"](#) on page 842
- ["Configure the scan action for a suspicious file"](#) on page 842
- ["Update the suspicious objects list in Deep Security"](#) on page 842
- ["Configure Threat Intelligence in a multi-tenant environment"](#) on page 843
- ["Supported file types"](#) on page 843
- ["Migrating from Connected Threat Defense to Threat Intelligence"](#) on page 844

For an overview of the Anti-Malware module, see ["About Anti-Malware"](#) on page 798.

How does Threat Intelligence work?

1. When all the components are configured properly, the Deep Security Agent uses heuristic detection to analyze files on the protected computer and determines whether they are suspicious.
2. Optionally, you can manually or automatically send suspicious files from Deep Security to Trend Micro Vision One or Deep Discovery Analyzer, which executes and observes the suspicious file in a sandbox (a secure, isolated virtual environment).
3. Deep Security Manager gets the sandbox analysis results from Trend Micro Vision One or Deep Discovery Analyzer.

Note: The sandbox analysis report doesn't provide protection; it simply provides information on the Trend Micro Vision One or Deep Discovery analysis. For complete protection, this feature requires a connection to Trend Micro Vision One or Trend Micro Apex Central. The report is retrieved from Trend Micro Vision One or Deep Discovery Analyzer every 15 minutes.

4. You can configure Deep Security to submit suspicious files to other services for further analysis. If submitting suspicious files to Trend Micro Vision One, the analysis results are forwarded to Trend Micro Vision One Threat Intelligence. If submitting suspicious files to

Deep Discovery Analyzer, it pushes the analysis results to Trend Micro Apex Central, where an action can be specified for the file based on the analysis. Once the action is specified, a list of emerging threats called a suspicious object list is created or updated. Other Trend Micro products, such as Deep Discovery Inspector or Deep Discovery Email Inspector, may also be connected to Trend Micro Vision One or Trend Micro Apex Central and able to update the list.

5. Optionally, you can configure Deep Security Manager to receive the list of suspicious objects from Trend Micro Vision One or Trend Micro Apex Central and send the list of suspicious objects to Deep Security Agents.

Check the Threat Intelligence prerequisites

Before connecting Deep Security to Deep Discovery, check that your environment meets these requirements:

- Deep Security Manager is installed and configured with Deep Security Agents protecting computers.

Optional:

- To connect to Trend Micro Vision One (XDR):
 - ["Integrate with Trend Micro Vision One \(XDR\) " on page 1901.](#)
 - Purchase the "Deep Security: Sandbox as a Service" license for submitting suspicious files to Trend Micro Vision One.
- To connect to Deep Discovery Analyzer, ensure that Deep Discovery Analyzer 5.5 is installed and the sandbox virtual machines are provisioned.
- To connect to Trend Micro Apex Central, ensure that Apex Central 2019 or later is installed.
- Add Deep Discovery Analyzer to the Trend Micro Apex Central Managed Servers. See the Trend Micro Apex Central documentation for details.

Set up a connection to Trend Micro Vision One

You can configure Deep Security to submit the suspicious files and retrieve the suspected object list from Trend Micro Vision One, share it with protected computers, and compare local objects against the Trend Micro Vision One Threat Intelligence Suspicious Object List.

1. In Deep Security Manager, go to **Administration > System Settings > Threat Intelligence**.
2. Select **Submit suspicious files to** and then **Trend Micro Vision One**.

3. Select **Compare objects against Suspicious Object List** and then **Trend Micro Vision One**.

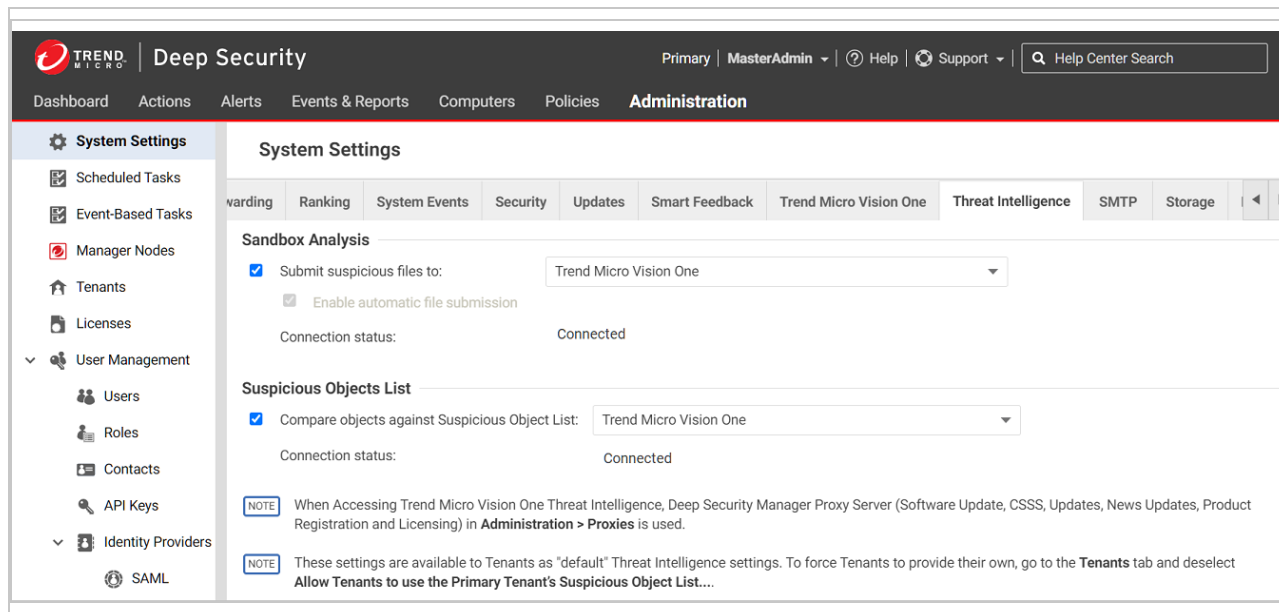

Set up a connection to Deep Discovery Analyzer

If you want Deep Security Manager to send suspicious files to Deep Discovery Analyzer for analysis, you'll need to set up a connection.

If Trend Micro Apex Central is already managing Deep Security

1. In Deep Security Manager, go to **Administration > System Settings > Threat Intelligence**.
2. Select **Submit suspicious files to** and then **Registered Deep Discovery Analyzer associated with Apex Central**.

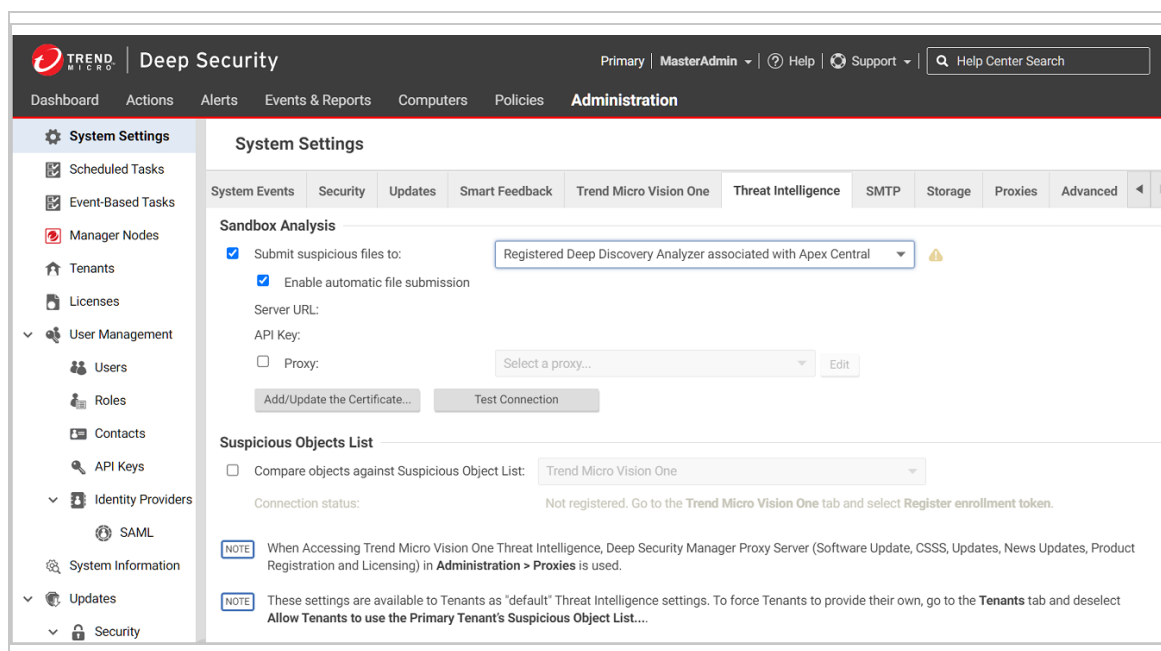

3. If you want Deep Security Manager to automatically submit files to Deep Discovery Analyzer, select **Enable automatic file submission**.

Note: Automatic Submission to Deep Discovery Analyzer occurs every 15 minutes and will submit a maximum of 100 files per submission.

4. Select **Test Connection**. If you get an error saying that Deep Security is unable to connect due to a missing or invalid certificate, select **Add/Update Certificate** to update to the correct Deep Discovery Analyzer certificate.
5. Select **Save**.

If Trend Micro Apex Central is not yet managing Deep Security

1. In Deep Discovery Analyzer, go to **Help > About** and note the **Service URL** and **API key**. You will need these values later, so copy them into a text file temporarily.
2. In Deep Security Manager, go to **Administration > System Settings > Threat Intelligence**.

3. Select **Submit suspicious files to** and then **Manually selected Deep Discovery Analyzer server** .

The screenshot shows the 'System Settings' page in Trend Micro Deep Security. The left sidebar contains navigation options like 'System Settings', 'Scheduled Tasks', 'Event-Based Tasks', 'Manager Nodes', 'Tenants', 'Licenses', 'User Management', 'Users', 'Roles', 'Contacts', 'API Keys', 'Identity Providers', 'SAML', 'System Information', 'Updates', and 'Security'. The main content area is titled 'System Settings' and has tabs for 'System Events', 'Security', 'Updates', 'Smart Feedback', 'Trend Micro Vision One', 'Threat Intelligence', 'SMTP', 'Storage', 'Proxies', and 'Advanced'. The 'Sandbox Analysis' section is active, showing a dropdown menu for 'Submit suspicious files to' set to 'Manually selected Deep Discovery Analyzer server'. Below it, the 'Enable automatic file submission' checkbox is checked. The 'Server URL' field is 'https://[server]/', 'API Key' is empty, and 'Proxy' is unchecked. There are 'Add/Update the Certificate...' and 'Test Connection' buttons. The 'Suspicious Objects List' section has a checkbox for 'Compare objects against Suspicious Object List' set to 'Trend Micro Vision One'. Two notes are present: one about accessing Trend Micro Vision One Threat Intelligence settings and another about tenant settings.

4. If you want Deep Security Manager to automatically submit files to Deep Discovery Analyzer, select **Enable automatic file submission**.

Note: Automatic Submission to Deep Discovery Analyzer occurs every 15 minutes and will submit a maximum of 100 files per submission

5. Enter the **Server URL** and **API key** that you found in step 1.
6. Select **Test Connection**. If you get an error saying that Deep Security is unable to connect due to a missing or invalid List certificate, select **Add/Update Certificate** to update to the correct Deep Discovery Analyzer certificate.
7. Select **Save**.

Set up a connection to Trend Micro Apex Central

When you configure these settings, Deep Security Manager will be able to retrieve the suspected object list from Trend Micro Apex Central, share it with protected computers, and compare local objects against the Apex Central Suspicious Object List.

If Trend Micro Apex Central is already managing Deep Security

1. In Deep Security Manager, go to **Administration > System Settings > Threat**

Intelligence.

2. Select **Compare objects against Suspicious Object List** and then **Registered Apex Central**.

Tip: If this option is not available, it is because Apex Central is not yet managing Deep Security, and you must follow the instructions "If Trend Micro Apex Central is not yet managing Deep Security" (below) instead.

The screenshot shows the Trend Micro Deep Security Administration interface. The top navigation bar includes 'Dashboard', 'Actions', 'Alerts', 'Events & Reports', 'Computers', 'Policies', and 'Administration'. The left sidebar lists 'System Settings' with sub-items like 'Scheduled Tasks', 'Event-Based Tasks', 'Manager Nodes', 'Tenants', 'Licenses', 'User Management', 'System Information', and 'Updates'. The main content area is titled 'System Settings' and has tabs for 'System Events', 'Security', 'Updates', 'Smart Feedback', 'Trend Micro Vision One', 'Threat Intelligence', 'SMTP', 'Storage', 'Proxies', and 'Advanced'. Under the 'Threat Intelligence' tab, there are two sections: 'Sandbox Analysis' and 'Suspicious Objects List'. Both sections have a checked checkbox for their respective functions and a dropdown menu set to 'Registered Apex Central'. Each section also includes fields for 'Server URL', 'API Key', and a 'Proxy' checkbox with a 'Select a proxy...' dropdown. Buttons for 'Add/Update the Certificate...' and 'Test Connection' are present in both sections. A note at the bottom states: 'NOTE These settings are available to Tenants as "default" Threat Intelligence settings. To force Tenants to provide their own, go to the Tenants tab and deselect Allow Tenants to use the Primary Tenant's Suspicious Object List...'.

3. Select **Test Connection**. If you get an error saying that Deep Security is unable to connect due to a missing or invalid certificate, select **Add/Update Certificate** to update to the correct Trend Micro Apex Central certificate.
4. Select **Save**.

If Trend Micro Apex Central is not yet managing Deep Security

1. In Trend Micro Apex Central, go to **Administration > Managed Servers > Server Registration**.

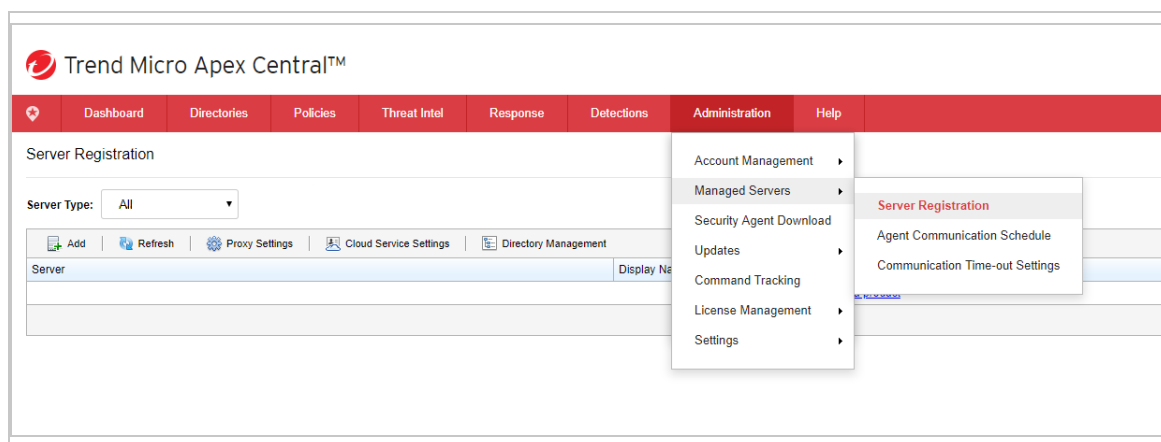

2. In the **Server Type** drop-down menu, select **Deep Security**.
3. Select **Add** to register Deep Security to the Apex Central server.

Note: Apex Central will automatically transfer the **Service URL** and **API key** needed to register Deep Security within 10 minutes of adding it as a managed product.

Create a malware scan configuration for use with Threat Intelligence

The following configuration allows Deep Security to detect suspicious files, back up the suspicious files, and automatically send them to Sandbox Analysis for further analysis.

1. In Deep Security Manager, go to **Policies > Common Objects > Other > Malware Scan Configurations**.
2. Create a new scan configuration or edit an existing configuration.
3. On the **General** tab, under **Document Exploit Protection**, select **Scan documents for exploits** and select one of these options:
 - **Scan for exploits against known critical vulnerabilities only:** Only detects known critical vulnerabilities. The CVE Exploit vulnerability type is associated with this option (See "[Customize malware remedial actions](#)" on page 821.)
 - **Scan for exploits against known critical vulnerabilities and aggressive detection of unknown suspicious exploits:** Detects more issues but may also result in more false positives. If you want to detect suspicious files and submit them to Trend Micro Vision One or Deep Discovery Analyzer, you must select this option. The Aggressive Detection Rule vulnerability type is associated with this option. (See "[Customize malware remedial actions](#)" on page 821.)

4. Configure the other malware scan settings as described in ["Configure malware scans and exclusions" on page 808](#).

Enable Threat Intelligence for your computers

You can enable Threat Intelligence in policies or for individual computers.

1. In the **Computer or Policy editor**¹, go to **Anti-Malware > General**.
2. Ensure that the **Anti-Malware State** is **On** or **Inherited (On)**.
3. The **General** tab contains sections for **Real-Time Scan**, **Manual Scan**, and **Scheduled Scan**. (For information on the different types of scans, see ["Enable and configure anti-malware" on page 805](#).) In the appropriate sections, use the **Malware Scan Configuration** list to select the scan configuration that you created above.
4. Go to the **Threat Intelligence** tab and adjust these settings as required:
 - If you want Deep Security to send suspicious files to Trend Micro Vision One or Deep Discovery Analyzer, set the option under **Sandbox Analysis** to **Yes** or **Inherited (Yes)**.
 - If you have set up a connection between Deep Security and Trend Micro Apex Central and you want to use the suspicious object list from Apex Central to detect malicious files, set **Use Suspicious Object List** (under **Suspicious Objects List**) to **Yes** or **Inherited (Yes)**.
5. Select **Save**.

Manually submit a file to Sandbox Analysis

You can manually submit files that appear on the **Events & Reports > Events > Anti-Malware Events > Identified Files** page.

1. Select the file that you want to submit and select the **Analyze** button.
2. Follow the steps in the wizard that appears.
3. After the file is submitted, you can check the progress of its analysis in the **Submission Status** column on the Identified Files page.
4. When the analysis is finished, the **Submission Status** column will display "Results Ready". You can select the **Results Ready** link to see details.

¹You can change these settings for a policy or for a specific computer. To change the settings for a policy, go to the Policies page and double-click the policy that you want to edit (or select the policy and click Details). To change the settings for a computer, go to the Computers page and double-click the computer that you want to edit (or select the computer and click Details).

Allow a file that has raised a false alarm

If a file is identified as malware on the **Events & Reports > Events > Anti-Malware Events > Identified Files** page but you know it's not malware, you can add it to the **Document Exploit Protection Rule Exceptions** list on the **Anti-Malware > Advanced** tab of the **Computer or Policy editor**¹.

To allow the file, right-click it, select **Allow**, and follow the steps in the wizard that appears.

Configure the scan action for a suspicious file

You can view the suspicious objects list in the Trend Micro Vision One or Trend Micro Apex Central console and configure the action (log, block, or quarantine) that should be taken when a suspicious object is found. (For details on configuring the actions, see the help for [Trend Micro Vision One](#) or [Apex Central](#).) If you have configured Deep Security Manager to obtain the suspicious object list from Trend Micro Vision One or Apex Central, Deep Security will perform the specified action when it finds the suspected object.

Note: Deep Security supports file suspicious objects. It also supports URL suspicious objects if the Web Reputation protection module is configured to use the Trend Micro Smart Protection Server. Deep Security does not support IP and domain suspicious objects.

Update the suspicious objects list in Deep Security

After the analysis of a suspicious object has been completed and the action for the file has been set in Trend Micro Vision One or Trend Micro Apex Central, Deep Security can use the Suspicious Object list from Trend Micro Vision One or Apex Central to protect your computers. To manually update the suspicious file list in Deep Security Manager, go to **Administration > Updates > Security** and use the controls in the Suspicious Object List Updates column to get the latest list and send it to your protected computers. You can also create a scheduled task that regularly checks for an updated list (see "[Schedule Deep Security to perform tasks](#)" on [page 1766](#)).

Note: In Trend Micro Apex Central, the default suspicious object setting is "Log". You may want to consider changing the default setting to "Quarantine" or "Block".

¹You can change these settings for a policy or for a specific computer. To change the settings for a policy, go to the Policies page and double-click the policy that you want to edit (or select the policy and click Details). To change the settings for a computer, go to the Computers page and double-click the computer that you want to edit (or select the computer and click Details).

In Trend Micro Vision One Threat Intelligence Suspicious Object Management, you can select the Default Settings in the upper-right corner, and specify the default actions to take on different types of objects at each risk level and the expiration settings for the objects. In Trend Micro Apex Central, the default suspicious object setting is "Log". You may want to consider changing the default setting to "Quarantine" or "Block".

Once the suspicious object list has been updated in Deep Security and the computer policies have been updated with the action specified, the Deep Security Agent then checks the affected computers and uses this action any time this file is encountered again on a protected computer.

Configure Threat Intelligence in a multi-tenant environment

In a multi-tenant environment, the primary tenant (t0) can choose whether to share their Deep Discovery Analyzer and Trend Micro Apex Central settings with their tenants. The setting that controls this behavior is **Administration > System Settings > Tenants > Allow Tenants to use Primary Tenant's Suspicious Object List and Sandbox Analysis settings**:

- When the setting is enabled and a tenant goes to **Administration > System Settings > Threat Intelligence**, they see an additional **Use default server settings** check box. When this check box is selected, the tenant uses the primary tenant's settings. When **Use default server settings** is not selected, the tenant can configure their own Threat Intelligence settings.
- If the primary tenant chooses **Trend Micro Vision One** to submit suspicious files and compare objects against the Suspicious Object List, the tenant will connect to their own Trend Micro Vision One account, NOT the primary tenant's Trend Micro Vision One account. Please be sure the tenants complete their own Trend Micro Vision One registration.
- When the setting is not enabled, tenants must use their own Trend Micro Vision One, or Trend Micro Apex Central and Deep Discovery Analyzer, if they want to use Threat Intelligence.

Supported file types

Deep Security can send these file types to Deep Discovery Analyzer:

- doc - Microsoft Word document
- docx - Microsoft Office Word 2007 document
- gul - JungUm Global document

- hwp - Hancom Hangul Word Processor (HWP) document
- hwpX - Hancom Hangul Word Processor 2014 (HWPX) document
- jar - Java Applet Java application
- js - JavaScript file
- jse - JavaScript encoded script file
- jtd - JustSystems Ichitaro document
- Ink - Microsoft Windows Shell Binary Link shortcut
- mov - Apple QuickTime media
- pdf - Adobe Portable Document Format (PDF)
- ppt - Microsoft Powerpoint presentation
- pptx - Microsoft Office PowerPoint 2007 Presentation
- ps1 - Microsoft Windows PowerShell script file
- rtf - Microsoft Rich Text Format (RTF) document
- swf - Adobe Shockwave Flash file
- vbe - Visual Basic encoded script file
- vbs - Visual Basic script file
- xls - Microsoft Excel spreadsheet
- .xlsx - Microsoft Office Excel 2007 Spreadsheet
- xml - Microsoft Office 2003 XML file

Migrating from Connected Threat Defense to Threat Intelligence

Threat Intelligence was introduced in Deep Security Manager 20.0.503 (20 LTS Update 2021-09-23). This section provides information about upgrading from earlier versions of Deep Security Manager with Connected Threat Defense to a newer version with Threat Intelligence, and setting up the connection to Trend Micro Vision One (XDR).

1. Ensure that Deep Security Manager is [registered with Trend Micro Vision One \(XDR\)](#).
2. In Deep Security Manager, go to **Administration > System Settings > Threat Intelligence**.
3. Select **Submit suspicious files to** and then **Trend Micro Vision One**.
4. Select **Compare objects against Suspicious Object List** and then **Trend Micro Vision One**.

5. Select **Save**. The **Connection status** will change to "Connected" within 15 minutes.

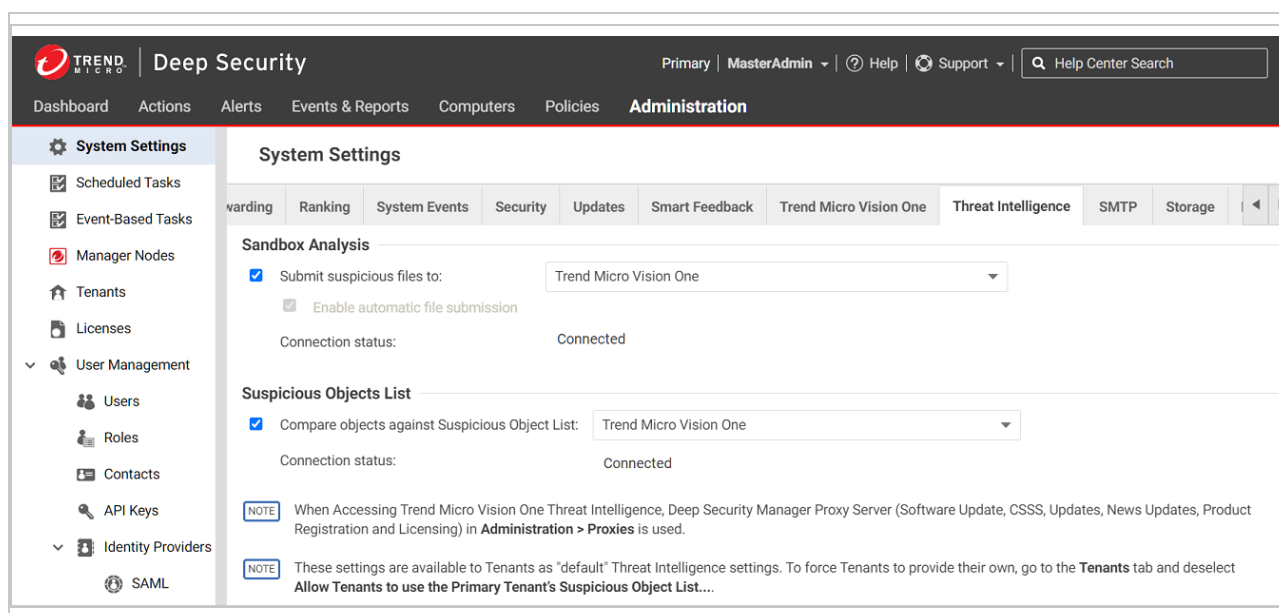

6. After Deep Security Manager submits a file sample, you can find the analysis summary in Trend Micro Vision One, under **Threat Intelligence > Sandbox Analysis**. For details, see the [Trend Micro Vision One help](#).
7. When a suspicious object is found, you can find the generated suspicious object list in Trend Micro Vision One, under **Threat Intelligence > Suspicious Object Management**. For details, see the [Trend Micro Vision One help](#).

Multi-tenant migration

If you are migrating from Connected Threat Defense to Threat Intelligence in a multi-tenant environment:

- The primary tenant should not enable the **Administration > System Settings > Tenants > Allow Tenants to use Primary Tenant's Suspicious Object List and Sandbox Analysis settings** option.
- After upgrade, all other tenants should open Deep Security Manager, go to **Administration > System Settings > Trend Micro Vision One**, and ensure that Deep Security Manager is [registered with Trend Micro Vision One \(XDR\)](#). The tenants can then configure their own Threat Intelligence settings in **Administration > System Settings > Threat Intelligence**.

Enhanced anti-malware and ransomware scanning with behavior monitoring

Deep Security provides security settings that you can apply to Windows and Linux machines that are protected by a Deep Security Agent to enhance your malware and ransomware detection and clean rate. These settings enable you to go beyond malware pattern matching and identify suspicious files that could potentially contain emerging malware that hasn't yet been added to the anti-malware patterns (known as a zero-day attack).

In this article:

- ["How does enhanced scanning protect you?" below](#)
- ["How to enable enhanced scanning" on the next page](#)
- ["What happens when enhanced scanning finds a problem?" on page 848](#)
- ["What if my agents can't connect to the Internet directly?" on page 853](#)

For an overview of the anti-malware module, see ["About Anti-Malware" on page 798](#).

How does enhanced scanning protect you?

Threat detection: To avoid detection, some types of malware attempt to modify system files or files related to known installed software. These types of changes often go unnoticed because the malware takes the place of legitimate files. Deep Security can monitor system files and installed software for unauthorized changes to detect and prevent these changes from occurring.

Anti-exploit: Malware writers can use malicious code to hook in to user mode processes in order to gain privileged access to trusted processes and to hide the malicious activity. Malware writers inject code into user processes through DLL injection, which calls an API with escalated privilege. They can also trigger an attack on a software exploit by feeding a malicious payload to trigger code execution in memory. In Deep Security, the anti-exploit functionality monitors for processes that may be performing actions that are not typically performed by a given process. Using a number of mechanisms, including Data Execution Prevention (DEP), Structured Exception Handling Overwrite Protection (SEHOP), and heap spray prevention, Deep Security can determine whether a process has been compromised and then terminate the process to prevent further infection.

Extended ransomware protection: Recently, ransomware has become more sophisticated and targeted. Most organizations have a security policy that includes anti-malware protection on their endpoints, which offers a level of protection against known ransomware variants; however, it

may not be sufficient to detect and prevent an outbreak for new variants. The ransomware protection offered by Deep Security can protect documents against unauthorized encryption or modification. Deep Security has also incorporated a data recovery engine that can optionally create copies of files being encrypted to offer users an added chance of recovering files that may have been encrypted by a ransomware process.

How to enable enhanced scanning

Enhanced scanning is configured as part of the anti-malware settings that are applied to a policy or individual computer. For general information on configuring anti-malware protection, see ["Enable and configure anti-malware" on page 805](#).

Note: These settings can only be applied to Windows and Linux machines that are protected by a Deep Security Agent.

Warning: Enhanced scanning may have a performance impact on agent computers running applications with heavy loads. We recommend reviewing the ["Performance tips for anti-malware" on page 825](#) before deploying Deep Security Agents with enhanced scanning enabled.

The first step is to enable enhanced scanning in a real-time malware scan configuration:

1. In Deep Security Manager, go to **Policies > Common Objects > Other > Malware Scan Configurations**.
2. Double-click an existing real-time scan configuration to edit it (for details on malware scan configurations, see ["Configure malware scans and exclusions" on page 808](#)).
3. On the **General** tab, under **Behavior Monitoring**, select **Enable Behavior Monitoring**. In the **Action to take** list, choose the remediation action that you want Deep Security to take when it detects malware:
 - **ActiveAction (recommended):** Use the action that ActiveAction determines. ActiveAction is a predefined group of cleanup actions that are optimized for each malware category. Trend Micro continually adjusts the actions in ActiveAction to ensure that individual detections are handled properly. (See ["ActiveAction actions" on page 822](#).)
 - **Pass:** Allows full access to the infected file without doing anything to the file. (An Anti-Malware Event is still recorded.)
4. Optionally, select **Back up and restore ransomware-encrypted files**. When this option is selected, Deep Security will create backup copies of files that are being encrypted, in case

they are being encrypted by a ransomware process. This option applies only to computers running Windows.

5. Click **OK**.

Note: By default, real-time scans are set to scan all directories. If you change the scan settings to scan a directory list, the enhanced scanning may not work as expected. For example, if you set **Directories to scan** to scan "Folder1" and ransomware occurs in Folder1, it may not be detected if the encryption associated with the ransomware happens to files outside of Folder1.

Next, apply the malware scan configuration to a policy or an individual computer:

1. In the **Computer or Policy editor**¹, go to **Anti-Malware > General**.
2. Ensure that the **Anti-Malware State** is **On** or **Inherited (On)**.
3. The General tab contains sections for **Real-Time Scan**, **Manual Scan**, and **Scheduled Scan**. In the appropriate sections, use the **Malware Scan Configuration** list to select the scan configuration that you created above.
4. Click **Save**.

What happens when enhanced scanning finds a problem?

When Deep Security discovers activity or files that match the enhanced scan settings you have enabled, it will log an event (go to **Events & Reports > Events > Anti-Malware Events** to see a list of events). The event will be identified as "Suspicious activity" or "Unauthorized change" in the **Major Virus Type** column and details will be displayed in the **Target(s)** and **TargetType** columns.

Deep Security performs many types of checks related to the enhanced scan settings, and the actions that it takes depend on the type of check that finds an issue. Deep Security may "Deny Access", "Terminate", or "Clean" a suspicious object. These actions are determined by Deep Security and are not configurable, with the exception of the "Clean" action:

- **Deny Access:** When Deep Security detects an attempt to open or execute a suspicious file, it immediately blocks the operation and records an anti-malware event.
- **Terminate:** Deep Security terminates the process that performed the suspicious operation and records an anti-malware event.

¹You can change these settings for a policy or for a specific computer. To change the settings for a policy, go to the Policies page and double-click the policy that you want to edit (or select the policy and click Details). To change the settings for a computer, go to the Computers page and double-click the computer that you want to edit (or select the computer and click Details).

- **Clean:** Deep Security checks the Malware Scan Configuration and performs the action specified for Trojans on the Actions tab. One or more additional events will be generated relating to the action performed on the Trojan files.

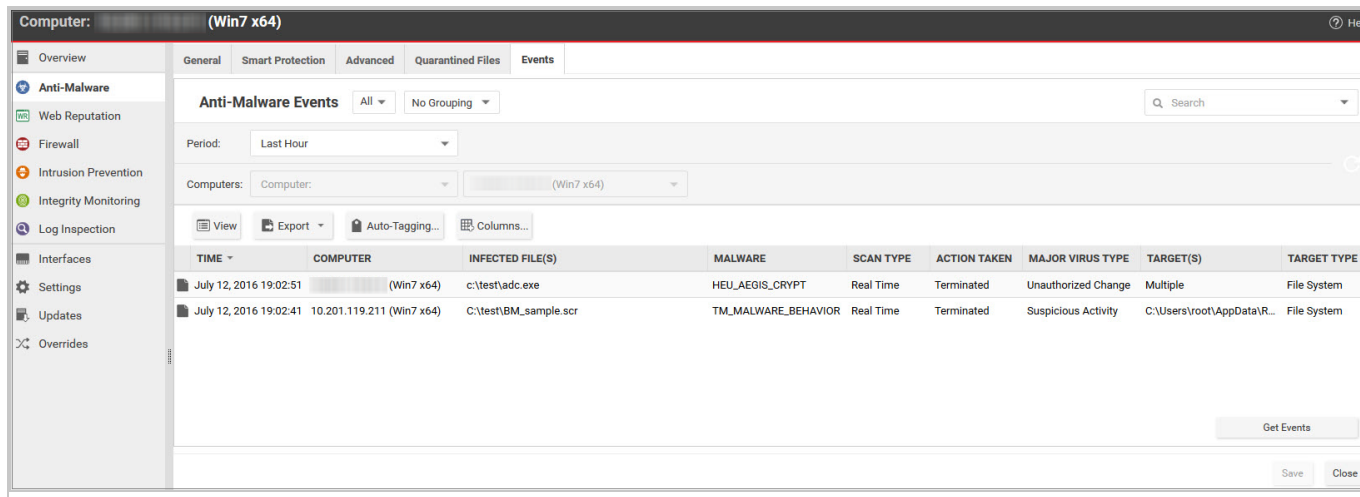

Double-click an event to see details:

General	Tags
General Information	
Computer:	(Win7 x64)
Origin:	Agent
Malware Information	
Detection Time:	July 12, 2016 19:02:41
Malware:	TM_MALWARE_BEHAVIOR
Infected File(s):	C:\test\BM_sample.scr
Scan Type:	Real Time
Action Taken:	Terminated
Reason:	Default Real-Time Scan Configuration
Major Virus Type:	Suspicious Activity
Behavior Monitoring Information	
Target:	C:\Users\root\AppData\Roaming\Microsoft\Windows\Start Menu\Programs\Startup\StartupFile.exe
TargetType:	File System
< Back Next > Close	

Events related to ransomware have an additional **Targeted Files** tab:

General	Targeted Files	Tags
General Information		
Computer:	[REDACTED] (Win7 x64)	
Origin:	Agent	
Malware Information		
Detection Time:	July 12, 2016 19:02:51	
Malware:	HEU_AEGIS_CRYPT	
Infected File(s):	c:\test\adc.exe	
Scan Type:	Real Time	
Action Taken:	Terminated	
Reason:	Default Real-Time Scan Configuration	
Major Virus Type:	Unauthorized Change	
Behavior Monitoring Information		
Target:	Multiple	
TargetType:	File System	
< Back		Next >
Close		

The screenshot displays the 'Targeted Files Information' section of the Trend Micro Deep Security console. It features a tabbed interface with 'General', 'Targeted Files', and 'Tags' tabs. Below the tabs is a section titled 'Targeted Files Information' containing an 'Export to CSV...' button. A table lists the attacking programs and their targets, with a 'RESTORE RESULT' column. The table contains three rows, all showing 'Success' for the restore result. At the bottom of the window, there are navigation buttons: '< Back', 'Next >', and 'Close'.

ATTACKING PROGRAM ^	TARGET	RESTORE RESULT
c:\test\adc.exe	c:\users\ds\documents\outloo...	Success
c:\test\adc.exe	c:\users\ds\documents\outloo...	Success
c:\test\adc.exe	c:\users\ds\documents\outloo...	Success

If you investigate and find that an identified file is not harmful, you can right-click the event and click **Allow** to add the file to a scan exclusion list for the computer or policy. You can check the scan exclusion list in the policy or computer editor, under **Anti-Malware > Advanced > Behavior Monitoring Protection Exceptions**.

What if my agents can't connect to the Internet directly?

The enhanced scanning features described in this article require Internet access to check files against the Global Census Server and Good File Reputation Service. If your Deep Security Agents cannot access the Internet directly, see ["Configure agents that have no internet access" on page 1453](#) for workarounds.

Smart Protection in Deep Security

Smart Protection Network integration is available for your computers and workloads through anti-malware and web reputation modules. Smart Feedback, which is set at the system level, allows you to provide continuous feedback to the Smart Protection Network.

For more about Trend Micro's Smart Protection Network, see [Smart Protection Network](#).

In this topic:

- ["Anti-malware and Smart Protection" below](#)
- ["Web Reputation and Smart Protection" on page 855](#)
- ["Smart Feedback" on page 856](#)

See also ["Integrate with Smart Protection Server" on page 1894](#) for AWS deployment instructions and [Smart Protection Server documentation](#) for instructions on manually deploying the server.

Anti-malware and Smart Protection

- [Benefits of Smart Scan](#)
- ["Enable Smart Scan" on the next page](#)
- ["Smart Protection Server for File Reputation Service" on page 855](#)

Benefits of Smart Scan

Smart Scan provides the following features and benefits:

- Provides fast, real-time security status lookup capabilities in the cloud.
- Reduces the overall time it takes to deliver protection against emerging threats.
- Reduces network bandwidth consumed during pattern updates. The bulk of pattern

definition updates only needs to be delivered to the cloud, not to many endpoints.

- Reduces the cost and overhead associated with corporate-wide pattern deployments.

Enable Smart Scan

Smart Scan is available in the anti-malware module. It uses Trend Micro's [Smart Protection Network](#) to allow local pattern files to be small and reduces the size and number of updates required by agents and Appliances. When Smart Scan is enabled, the agent downloads a small version of the much larger full malware pattern from a Smart Protection Server. This smaller pattern can quickly identify files as either *confirmed safe* or *possibly dangerous*. Possibly dangerous files are compared against the larger complete pattern files stored on Trend Micro Smart Protection Servers to determine with certainty whether they pose a danger or not.

Without Smart Scan enabled, your relay agents must download the full malware pattern from a Smart Protection Server to be used locally on the agent. The pattern will only be updated as scheduled security updates are processed. The pattern is typically updated once per day for your agents to download and is around 120 MB.

You should verify that the computer can reliably connect to the global Trend Micro Smart Protection Network URLs. For details, see ["Port numbers, URLs, and IP addresses" on page 410](#). If connectivity is blocked by a firewall, proxy, or AWS security group, or if the connection is unreliable, it anti-malware performance is reduced.

1. Go to **Policies**.
2. Double-click a policy.
3. Go to **Anti-Malware > Smart Protection**.
4. In the **Smart Scan** section, either:
 - Select **Inherited** (if the parent policy has Smart Scan enabled).
 - Deselect **Inherited**, and then select either **On** or **On for Deep Security Agent, Off for Virtual Appliance**.
5. Click **Save**.

Note: A computer that is configured to use Smart Scan does not download full anti-malware patterns locally. Therefore, if your anti-malware license expires while a computer is configured to use Smart Scan, switching Smart Scan off does not result in local patterns being used to scan for malware since no anti-malware patterns is present locally.

Smart Protection Server for File Reputation Service

Smart Protection Server for File Reputation Service is available in the anti-malware module. It supplies file reputation information required by Smart Scan.

You edit Smart Protection Server for File Reputation Service as follows:

1. Go to **Computers** or **Policies > Anti-Malware > Smart Protection**.
2. Select to connect directly to Trend Micro's Smart Protection Server or to connect to one or more locally installed Smart Protection Servers.
3. If you want to use a proxy for communication between agents and the Smart Protection Network, you should create a proxy server specifically for the Smart Protection Network. You can view and edit the list of available proxies on the **Proxies** tab on the **Administration > System Settings** page. For information on proxy protocols, see "[Supported proxy protocols](#)" on page 1405.
4. Select the **When off domain, connect to global Smart Protection Service (Windows only)** option to use the global Smart Protection Service if the computer is off domain. The computer is considered to be off domain if it cannot connect to its domain controller (this option is for Windows agents only).

Note: If you have a locally installed Smart Protection Server, this option should be set to **Yes** on at least one computer so that you are notified if there is a problem with the Smart Protection Server itself.

5. Set **Smart Protection Server Connection Warning** to generate error events and alerts when a computer loses its connection to the Smart Protection Server.

Web Reputation and Smart Protection

Smart Protection Server for Web Reputation supplies web reputation information required by the web reputation module.

You edit Smart Protection Server for Web Reputation Service as follows:

1. Go to **Computers** or **Policies > Web Reputation > Smart Protection**.
2. Select to connect directly to Trend Micro's Smart Protection Server or to connect to one or more locally installed Smart Protection Servers.
3. If you want to use a proxy for communication between agents and the Smart Protection Network, you should create a proxy server specifically for the Smart Protection Network. You can view and edit the list of available proxies on the **Proxies** tab on the **Administration > System Settings** page. For information on proxy protocols, see "[Supported proxy protocols](#)" on page 1405.

4. Select **When off domain, connect to global Smart Protection Service (Windows only)** to use the global Smart Protection Service if the computer is off domain. The computer is considered to be off domain if it cannot connect to its domain controller (this option is for Windows agents only).
5. Set **Smart Protection Server Connection Warning** to generate error events and alerts when a computer loses its connection to the Smart Protection Server.

Smart Feedback

Trend Micro Smart Feedback provides continuous communication between Trend Micro products and the company's 24/7 threat research centers and technologies. With Smart Feedback, products become an active part of the Trend Micro Smart Protection Network, where large amounts of threat data is shared and analyzed in real time. This interconnection enables never before possible rates of analysis, identification, and prevention of new threats—a level of responsiveness that addresses the thousands of new threats and threat variants released daily.

Trend Micro Smart Feedback is a system setting in the Deep Security Manager. When enabled, Smart Feedback shares protected threat information with the Smart Protection Network, allowing Trend Micro to rapidly identify and address new threats. By default, Smart Feedback is enabled. You can disable it or adjust its settings by going to **Administration > System Settings > Smart Feedback**.

Smart Feedback uses **Update Source Proxy** in the **Relay Group Properties** area via **Administration > Updates > Relay Management**. For details, see [Connect to the Primary Security Update Source via proxy](#).

Handle malware

View and restore identified malware

An identified file is a file that has been found to be or to contain malware and has therefore been encrypted and moved to a special folder on the protected computer. Whether or not an infected file can be viewed and restored depends on the anti-malware configuration and the operating system on which the file was found:

- On Windows agents, you can view and restore "[Customize malware remedial actions](#)" on [page 821](#) files.
- On Linux agents, you can view and restore only quarantined files.

Topics on this page:

- ["See a list of identified files" below](#)
- ["Working with identified files" on the next page](#)
- ["Search for an identified file" on page 859](#)
- ["Restore identified files " on page 861](#)
- ["Manually restore identified files" on page 864](#)

For information about events that are generated when malware is encountered, see ["Anti-malware events" on page 1350](#).

See a list of identified files

The Events and Reports page provides a list of identified files. From there you can see the details for any of those files:

1. Click **Events and Reports > Events > Anti-Malware Events > Identified Files**.
2. To see the details of a file, select the file and click **View**.

The list of identified files includes the following columns of information:

- **Infected File:** Shows the name of the infected file and the specific security risk.
- **Malware:** Names the malware infection.
- **Computer:** Indicates the name of the computer with the suspected infection.
- **File Status:** Indicates whether or not a file is ready for download.



The Details window provides the following information:

- **Detection Time:** The date and time on the infected computer that the infection was detected.
- **Infected File(s):** The name of the infected file.
- **File SHA-1:** The SHA-1 hash of the file.
- **Malware:** The name of the malware that was found.
- **Scan Type:** Indicates whether the malware was detected by a Real-time, Scheduled, or Manual scan.
- **Action Taken:** The result of the action taken by Deep Security when the malware was detected.
- **Computer:** The computer on which this file was found. (If the computer has been removed, this entry will read "Unknown Computer".)
- **Container Name:** Name of the Docker container where the malware was found.





- **Container ID:** ID of the Docker container where the malware was found.
- **Container Image Name:** Image name of the Docker container where the malware was found.



Working with identified files

The **Identified Files** page allows you to manage tasks related to identified files. Using the menu bar or the context menu, you can do the following:

-  **Restore** identified files back to their original location and condition. Note that you cannot perform this action if your host uses the **Agent/Appliance Initiated** communication.
-  **Download** identified files from the computer or Virtual Appliance to a location of your choice. To download files:
 - a. Select the files you want to download.
 - b. Go to **Download > Request download**. The **File Status** column indicates that the download is pending.
 - c. Once the file is ready for download, the **File Status** column changes to **Ready for download** and the system event **Identified file is ready for download** appears.
 - d. Select the identified files that are ready to be downloaded.
 - e. Go to **Download > Download**.

Once a file is ready for download, you have 24 hours to download the file to your location of choice.

-  **Analyze** identified files from the computer or Virtual Appliance.
-  **Delete** one or more identified files from the computer or Virtual Appliance. Note that you cannot perform this action if your host uses the **Agent/Appliance Initiated** communication.
-  **Export** information about the identified files (not the file itself) to a CSV file.
-  **View** the details of an identified file.
-  **Computer Details** displays the screen of the computer on which the malware was detected.

-  **View Anti-Malware Event** displays the anti-malware event associated with this identified file.
-  **Add or Remove Columns** by clicking **Add/Remove**.
-  **Search** for a particular identified file.

Identified files are automatically deleted from a Deep Security Virtual Appliance when the following occurs:

- A VM is moved to another ESXi host by vMotion. Identified files associated with that VM are deleted from the virtual appliance.
- A VM is deactivated from the Deep Security Manager. Identified files associated with that VM are deleted from the virtual appliance.
- Deep Security Virtual Appliance is deactivated from the Deep Security Manager. All the identified files stored on that virtual appliance are deleted.
- Deep Security Virtual Appliance is deleted from the vCenter. All identified files stored on that virtual appliance are deleted.

Search for an identified file

- Use the **Period** drop-down menu to see only the files that were identified within a specific time frame.
- Use the **Computers** drop-down menu to organize files by Computer Groups or Computer Policies.
- Click **Search this page > Open Advanced Search** to toggle the display of the advanced search options:

Identified Files No Grouping ▾ Search th

Period: Last Hour ▾

Computers: All Computers ▾

Search: Infected File(s) ▾ Contains ▾

Delete... View Export ▾ Restore... Download... Columns...

Advanced searches include one or more search criteria for filtering identified files. Each criterion is a logical statement comprised of the following items:

- The characteristic of the identified file to filter on, such as the type of file (infected file or malware) or the computer that was affected.
- An operator:
 - **Contains:** The entry in the selected column contains the search string.
 - **Does Not Contain:** The entry in the selected column does not contain the search string.
 - **Equals:** The entry in the selected column exactly matches the search string.
 - **Does Not Equal:** The entry in the selected column does not exactly match the search string.
 - **In:** The entry in the selected column exactly matches one of the comma-separated search string entries.
 - **Not In:** The entry in the selected column does not exactly match any of the comma-separated search string entries.
- A value.

To add a criterion, click the "plus" button (+) to the right of the topmost criterion. To search, click the Search button (the circular arrow).

Note: Searches are not case-sensitive.

Restore identified files

Create a scan exclusion for the file

Before you can restore a file to its original location, you have to create a scan exclusion so that Deep Security doesn't immediately re-identify the file when it reappears on the computer.

Note: The following instructions describe how to create an exclusion for the file on an individual computer but you can make the same configuration changes at the policy level.

1. Open the Computers page and go to **Anti-Malware > Identified Files** and double click the identified file to view its properties.
2. Note the file's exact name and original location.
3. Still in the Computers page, go to **Anti-Malware > General** and click the Edit button next to each Malware Scan that's in effect to open the Malware Scan Configuration properties

window.

Computer: laptop_adaggs (lap)

Overview | **General** | Smart Protection | Advanced | Quarantined Files | Events

Anti-Malware

Configuration: Inherited (On) ▾

State: ● On, matching module plug-in not found, Real Time

Real-Time Scan

Inherited

Malware Scan Configuration: Default Real-Time Scan Configuration ▾ **Edit**

Schedule: Every Day All Day ▾ **Edit**

Manual Scan

Inherited

Malware Scan Configuration: Default Manual Scan Configuration ▾ **Edit**

Scheduled Scan

Inherited

Malware Scan Configuration: Default Scheduled Scan Configuration ▾ **Edit**

Malware scan

Last Manual Scan for Malware: N/A

Last Scheduled Scan for Malware: N/A

Quick Scan for Malware | Full Scan for Malware | Cancel M

4. In the **Malware Scan Configuration** properties window, click on the **Exclusions** tab.
5. In the **Scan Exclusions** area, select **File List** and then either press edit if a file list is already selected, or select **New** from the menu to create a new File List.

- In the **File List** properties window, enter the file path and name of the file to be restored. Click **OK** to close the File List properties window.

The screenshot shows a dialog box with two tabs: 'General' and 'Assigned To'. The 'General' tab is active. Under 'General Information', the 'Name' field contains 'New File List' and the 'Description' field is empty. Below this, the 'File(s): (One file per line)' field contains the text 'C:\Documents\testfile.doc'. The 'Supported Formats:' section includes a blue 'NOTE' box stating: 'The "Process Image File List" only handles full path, other formats are ignored.' Below the note, there are several categories with examples:

- File:**
 - FILE Example: testfile.doc
 - FILEPATH Example: C:\Documents\testfile.doc
- File with WildCard (*):**
 - FILE* Example: MyApp*.vApp
 - FILE.EXT* Example: MyApp.v*
- Environment Variable:**
 - \$(ENV VAR) Example: \$(myDBFile)
- Comments:**
 - FILEPATH #Comment Example: C:\temp\file.txt #Exclude

At the bottom of the dialog are 'OK' and 'Cancel' buttons.

- Close the **Malware Scan Configuration** properties window by clicking **OK**.
- When you've edited all the **Malware Scan Configurations**, click **Save** in the Computers page to save your changes. You're now ready to restore your file.

Restore the file

1. Still in the Computers page, go to the **Anti-Malware > Identified Files** tab.
2. Right-click the identified file and select **Actions > Restore** and follow the steps in the wizard.

Your file is restored to its original location.

Manually restore identified files

To manually restore an identified file, download the file to your computer. The **Identified File** wizard will display a link to an **Administration Utility** which you can use to decrypt, examine, or restore the file. Use the quarantined file decryption utility to decrypt the file and then move it back to its original location.

The decryption utility is in a zip file, **QFAdminUtil_win32.zip**, located in the "util" folder under the Deep Security Manager root directory. The zipped file contains two utilities which perform the same function: **QDecrypt.exe** and **QDecrypt.com**. Running **QDecrypt.exe** invokes an open file dialog that lets you select the file for decryption. **QDecrypt.com** is a command-line utility with the following options:

- **/h, --help**: show this help message
- **--verbose**: generate verbose log messages
- **/i, --in=<str>**: quarantined file to be decrypted, where **<str>** is the name of the quarantined file
- **/o, --out=<str>**: decrypted file output, where **<str>** is the name given to the resulting decrypted file

Note: This utility is supported on Windows 32-bit systems and Windows 64-bit systems.

Configure advanced exploit exceptions

Files that are not malicious can be falsely identified as malware if they share certain characteristics with malware. If a file is known to be benign and is identified as malware, you can create an exception for that file. When an exception is created, the file does not trigger an event when Deep Security scans the file.

For an overview of the anti-malware module, see ["About Anti-Malware" on page 798](#).

You can also exclude files from real-time, manual, and scheduled scans. For more information, see ["Specify the files to scan" on page 813](#).

Exceptions can be created for the following types of malware and malware scans:

- Predictive Machine Learning scans. For more information, see ["Detect emerging threats using Predictive Machine Learning" on page 832](#).
- Document exploit protection scans. For more information, see ["Detect emerging threats using Threat Intelligence" on page 833](#).
- Scans for spyware and grayware. For more information, see ["Scan for spyware and grayware" on page 811](#).
- Behavior monitoring protection. For more information, see ["Enhanced anti-malware and ransomware scanning with behavior monitoring" on page 846](#).

You can also exclude files from Anti-Malware scanning if they are signed by a trusted certificate. This feature is supported with Deep Security Agent 20.0.0-3445+ on Windows. For details, see ["Exclude files signed by a trusted certificate" on page 870](#).

Deep Security maintains a list of exceptions for each type of malware scan in policy and computer properties.

1. To see the lists of exceptions, open the policy or computer editor.
2. Click **Anti-Malware > Advanced**.

The exceptions are listed in the **Allowed Spyware/Grayware**, **Document Exploit Protection Rule Exceptions**, **Predictive Machine Learning Detection Exceptions**, **Behavior Monitoring Protection Exceptions**, and **Trusted Certificates Detection Exceptions** sections.

See also ["Scan exclusion recommendations" on page 869](#).

Create an exception from an anti-malware event

When a file is identified as malware, Deep Security generates an anti-malware event. If you know that the file is benign, you can create an exception for the file from the event report, as follows:

1. Click **Events & Reports > Events > Anti-Malware Events** and locate the malware detection event.
2. Right-click the event.
3. Select **Allow**.

Manually create an anti-malware exception

You can manually create anti-malware exceptions for spyware or grayware, document exploit protection rules, predictive machine learning, and behavior monitoring exceptions. To add the exception, you need specific information from the anti-malware event that the scan generated. The type of malware or scan determines the information that you need:

- **Spyware or grayware:** The value in the MALWARE field, for example `SPY_CCFR_CPP_TEST.A`
- **Document exploit protection rules:** The value in the MALWARE field, for example `HEUR_OLEP.EXE`
- **Predictive machine learning:** The SHA1 digest of the file from the FILE SHA-1 field, for example `3395856CE81F2B7382DEE72602F798B642F14140`
- **Behavior monitoring:** The process image path, for example `C:\test.exe`

1. Click **Events & Reports > Events > Anti-Malware Events** and copy the field value that is required to identify the malware.
2. Open the policy or computer editor where you want to create the exception.
3. Click **Anti-Malware > Advanced**.
4. In the **Allowed Spyware/Grayware, Document Exploit Protection Rule Exceptions, Predictive Machine Learning Detection Exceptions, or Behavior Monitoring Protection Exceptions** section, enter the information from the event in the text box.
5. Click **Add**.

Exception List Wildcard Support

The **Behavior Monitoring Protection Exceptions** list supports the use of wildcard characters when defining file path, file name, and file extension exception types. Use the following table to properly format your exception lists to ensure that Deep Security excludes the correct files and folders from scanning.

Supported wildcard characters:

- Asterisk (*): Represents any character or string of characters

Note that the Behavior Monitoring Protection Exceptions list does not support the use of wildcard characters to replace system drive designations or within Universal Naming Convention (UNC) addresses.

Exception Type	Wildcard Usage	Matched	Not Matched
Directories	<p>C:*</p> <p>Excludes all files and folders on the specified drive</p>	<ul style="list-style-type: none"> C:\sample.exe C:\folder\test.doc 	<ul style="list-style-type: none"> D:\sample.exe E:\folder\test.doc
Specific files under a specific folder level	<p>C:*\Sample.exe</p> <p>Excludes the Sample.exe file only if the file is located in any subfolder of the C:\ directory</p>	<ul style="list-style-type: none"> C:\files\Sample.exe C:\temp\files\Sample.exe 	<ul style="list-style-type: none"> C:\sample.exe
Universal Naming Convention (UNC) paths	<p>\\<UNC path>*\Sample.exe</p> <p>Excludes the Sample.exe file only if the file is located in any subfolder of the specified UNC path</p>	<ul style="list-style-type: none"> \\<UNC path>\files\Sample.exe \\<UNC path>\temp\files\Sample.exe 	<ul style="list-style-type: none"> R:\files\Sample.exe <p>Reason: Mapped drives are not supported.</p> <ul style="list-style-type: none"> \\<UNC path>\Sample.exe <p>Reason: The file does not exist within a subfolder of the UNC path.</p>
File names and extensions	<p>C:*.*</p> <p>Excludes all files with extensions in all folders and subfolders of the</p>	<ul style="list-style-type: none"> C:\Sample.exe C:\temp\Sample.exe C:\test.doc 	<ul style="list-style-type: none"> D:\sample.exe C:\Sample <p>Note: Because C:\Sample does</p>

Exception Type	Wildcard Usage	Matched	Not Matched
	C:\ directory		not have a file extension, it is not a match for the exception.
File names	C:*.exe Excludes all files with the .exe extension in all folders and subfolders of the C:\ directory	<ul style="list-style-type: none"> C:\Sample.exe C:\temp\test.exe 	<ul style="list-style-type: none"> C:\Sample.doc C:\temp\test.bat C:\Sample <p>Note: Because C:\Sample does not have a file extension, it is not a match for the exception.</p>
File extensions	C:\Sample.* Excludes all files with the name Sample and any extension in the C:\ directory	<ul style="list-style-type: none"> C:\Sample.exe 	<ul style="list-style-type: none"> C:\Sample1.doc C:\temp\Sample.bat C:\Sample <p>Note: Because C:\Sample does not have a file extension, it is not a match for the exception.</p>
Files in specific directory	C:**\Sample.exe	<ul style="list-style-type: none"> C:\files\temp\Sample.exe C:\files\temp\test\ 	<ul style="list-style-type: none"> C:\Sample.exe C:\temp\Sample.exe

Exception Type	Wildcard Usage	Matched	Not Matched
structures	Excludes all files located within the second subfolder level or any subsequent subfolders of the <code>C:\</code> directory with the file name and extension <code>Sample.exe</code>	<code>Sample.exe</code>	<ul style="list-style-type: none"> <code>C:\files\temp\Sample.doc</code>

Exception strategies for spyware and grayware

When spyware is detected, the malware can be immediately cleaned, quarantined, or deleted, depending on the malware scan configuration that controls the scan. After you create the exception for a spyware or grayware event, you might have to restore the file. For more information, see ["Restore identified files " on page 861](#).

Alternatively, you can temporarily scan for spyware and grayware with the action set to Pass so that all spyware and grayware detections are recorded on the Anti-Malware Events page but not cleaned, quarantined, or deleted. You can then create exceptions for the detected spyware and grayware. When your exception list is robust, you can set the action to Clean, Quarantine, or Delete modes.

For information about setting the action, see ["Configure malware handling" on page 820](#).

Scan exclusion recommendations

The best and most comprehensive source for scan exclusions is from the software vendor. The following are some high-level scan exclusion recommendations:

- Quarantine folders (such as `SMEX` on Microsoft Windows Exchange Server) should be excluded to avoid rescanning files that have already been confirmed to be malware.
- Large databases and database files (for example, `dsm.mdf` and `dsm.ldf`) should be excluded because scanning could impact database performance. If it is necessary to scan database files, you can create a scheduled task to scan the database during off-peak

hours. Since Microsoft SQL Server databases are dynamic, exclude the directory and backup folders from the scan list:

For Windows:

```
$(ProgramFiles)\Microsoft SQL Server\MSSQL\Data\
```

```
$(Windir)\WINNT\Cluster\ # if using SQL Clustering
```

```
Q:\ # if using SQL Clustering
```

For Linux:

```
/var/lib/mysql/ # if path is set to this Data Location of MySQL in the machine.
```

```
/mnt/volume-mysql/ # if path is set to this Data Location of MySQL in the machine.
```

For a list of recommended scan exclusions, see the [Trend Micro recommended scan exclusion list](#). Microsoft also maintains an [Anti-Virus Exclusion List](#) that you can use as a reference for excluding files from scanning on Windows servers.

Exclude files signed by a trusted certificate

If you have signed applications and want to exclude all activities of those processes from real-time Anti-Malware scanning (including file scans, behavior monitoring, and predictive machine learning), you can add the digital certificate to your trusted certificate list in Deep Security Manager, as follows:

1. In the policy or computer editor, go to **Anti-Malware > Advanced**.
2. In the **Trusted Certificates Detection Exemptions** section, set **Exclude files with trusted certificate** to "Yes" or "Inherited (Yes)".
3. Select **Manage Certificate List**.
4. The Trusted Certificates window displays any certificates you have imported. Select **Import From File** to add another one for scan exclusions.
5. Choose the certificate file and then select **Next**.
6. Review the certificate summary that's displayed and set **Trust this certificate for** to **Scan Exclusions**. Select **Next**.
7. The Summary page indicates whether the import was successful. Select **Close**.

Note: This type of exclusion is supported with Deep Security Agent 20.0.0-3445+ on Windows.

The imported certificate appears in the Trusted Certificates list with the **Purpose** listed as **Exception**.

Tip: Deep Security checks the exemption list when a process starts. If a process is running before the exemption is configured, the process will not be added to the exemption list until it is restarted.

Increase debug logging for anti-malware in protected Linux instances

You can increase or decrease verbosity of the anti-malware (AM) debug logging used to diagnose any issue related to AM when running on a Linux operating system.

Anti-malware debug logs are automatically included when you create a diagnostic package for technical support.

For information on creating a diagnostic package, see ["Create a diagnostic package and logs" on page 1951](#).

To increase the anti-malware debug log level, enter the following command in a shell on the Linux instance as a superuser:

```
killall -USR1 ds_am
```

This command will increase the level one unit. By default the level is 6 and the maximum is 8.

To decrease the anti-malware debug log level, enter the following command in a shell on the Linux instance as a superuser:

```
killall -USR2 ds_am
```

This command decreases the level by one unit. The minimum level is 0.

Note: If your Linux distribution doesn't use `killall` you can substitute it with the `pkill` command.

Configure Web Reputation

Note: For a list of operating systems where web reputation is supported, see ["Supported features by platform" on page 360](#).

The Web Reputation module protects against web threats by blocking access to malicious URLs. Deep Security uses Trend Micro's Web security databases from [Smart Protection Network](#) sources to check the reputation of websites that users are attempting to access. The website's reputation is correlated with the specific web reputation policy enforced on the computer. Depending on the [security level](#) being enforced, Deep Security either blocks or allows access to the URL.

Note: The Web Reputation module does not block HTTPS traffic.

You can enable and configure Web Reputation by performing the following steps:

1. ["Enable the web reputation module" below](#)
2. ["Enable the Trend Micro Toolbar" below](#)
3. ["Switch between inline and tap mode" on the next page](#)
4. ["Enforce the security level" on page 874](#)
5. ["Create exceptions" on page 874](#)
6. ["Configure the Smart Protection Server" on page 876](#)
7. ["Edit advanced settings" on page 877](#)
8. ["Test Web Reputation" on page 877](#)

For information on how to suppress messages that appear to users of agent computers, see ["Configure notifications on the computer" on page 824](#)

Enable the web reputation module

1. Go to **Policies**.
2. Double-click the policy for which you want to enable web reputation.
3. Click **Web Reputation > General**.
4. For **Web Reputation State**, select **On**.
5. Click **Save**.

Enable the Trend Micro Toolbar

After you enable the Trend Micro Toolbar, if you use your web browser to visit a dangerous, highly suspicious, or suspicious website, you will see a blocking page in the main window of your web browser and a message in the Windows notification area. In addition, attempts to access a URL rated as dangerous, highly suspicious, or suspicious are logged in Workload Security's **Web Reputation Events** tab.

When the Trend Micro Toolbar is included in your browser extensions, a small Trend Micro logo appears in your browser:

- In Chrome and Firefox, the logo appears to the right of the website address field.

Install the toolbar for Windows

The **Trend Micro Toolbar** extension for Windows is supported only on certain Windows platforms. It is currently supported with Chrome and Microsoft Edge browsers. See the ["Supported features by platform" on page 360](#) tables for more details.

The **Trend Micro Toolbar** for Windows is downloaded automatically when the Web Reputation module is enabled. The browser is installed the next time the web browser is restarted.

Switch between inline and tap mode

Web reputation uses the Deep Security Network Engine which can operate in one of two modes:

- **Inline:** Packet streams pass directly through the Deep Security network engine. All rules are applied to the network traffic before they proceed up the protocol stack.
- **Tap mode:** Packet streams are not modified. The traffic is still processed by Web Reputation, if it's enabled. However any issues detected do not result in packet or connection drops. When in Tap mode, Deep Security offers no protection beyond providing a record of events.

In tap mode, the live stream is not modified. All operations are performed on the replicated stream. When in tap mode, Deep Security offers no protection beyond providing a record of events.

To switch between inline and tap mode, open the **Computer or Policy editor**¹ and go to **Settings > Advanced > Network Engine Mode**.

For more on the network engine, see ["Test Firewall rules before deploying them" on page 927](#).

¹You can change these settings for a policy or for a specific computer. To change the settings for a policy, go to the Policies page and double-click the policy that you want to edit (or select the policy and click Details). To change the settings for a computer, go to the Computers page and double-click the computer that you want to edit (or select the computer and click Details).

Enforce the security level

Web addresses that are known to be or are suspected of being malicious are assigned a **risk level** of:

- **Dangerous:** Verified to be fraudulent or known sources of threats
- **Highly suspicious:** Suspected to be fraudulent or possible sources of threats
- **Suspicious:** Associated with spam or possibly compromised

Security levels determine whether Deep Security allows or blocks access to a URL, based on the associated risk level. For example, if you set the security level to low, Deep Security will only block URLs that are known to be web threats. As you set the security level higher, the web threat detection rate improves but the possibility of false positives also increases.

To configure the security level:

1. Go to **Policies**.
2. Double-click the policy that you want to edit.
3. Click **Web Reputation > General**.
4. Select one of the following security levels:
 - **High:** Blocks pages that are:
 - Dangerous
 - Highly suspicious
 - Suspicious
 - **Medium:** Blocks pages that are:
 - Dangerous
 - Highly Suspicious
 - **Low:** Blocks pages that are:
 - Dangerous
5. Click **Save**.

Create exceptions

You can override the block and allow behavior dictated by the Smart Protection Network's assessments with your lists of URLs that you want to block or allow.

Note: The **Allowed** list takes precedence over the **Blocked** list. URLs that match entries in the **Allowed** list are not checked against the **Blocked** list.

To create URL exceptions:

1. Go to **Policies**.
2. Double-click the policy that you want to edit.
3. Click **Web Reputation > Exceptions**.
4. To allow URLs:
 - a. Go to the **Allowed** section.
 - b. In the blank under **URLs to be added to the Allowed list (one per line)**, enter your desired URL. Multiple URLs can be added at once but they must be separated by a line break.
 - c. Select either:
 - **Allow URLs from the domain:** Allow all pages from the domain. Sub-domains are supported. Only include the domain (and optionally sub-domain) in the entry. For example, "example.com" and "another.example.com" are valid entries.
 - **Allow the URL:** The URL as entered will be allowed. Wildcards are supported. For example, "example.com/shopping/coats.html", and "example.com/shopping/*" are valid entries.
 - d. Click **Add**.

To block URLs:

- a. Go to the **Blocked** section
 - b. In the blank under **URLs to be added to the Blocked list (one per line)**, enter your desired URL. Multiple URLs or keywords can be added at once but they must be separated by a line break.
 - c. Select either:
 - **Block URLs from the domain:** Block all pages from the domain. Sub-domains are supported. Only include the domain (and optionally sub-domain) in the entry. For example, "example.com" and "another.example.com" are valid entries.
 - **Block the URL:** The URL as entered will be blocked. Wildcards are supported. For example, "example.com/shopping/coats.html", and "example.com/shopping/*" are valid entries.
 - **Block URLs containing this keyword:** Any URL containing the keyword will be blocked.
 - d. Click **Add**.
5. Click **Save**.

Configure the Smart Protection Server

Smart Protection Service for web reputation supplies web information required by the web reputation module. For more information, see [Smart Protection Network - Global Threat Intelligence](#).

To configure Smart Protection Server:

1. Go to **Policies**.
2. Double-click the policy you'd like to edit.
3. Click **Web Reputation > Smart Protection**.
4. Select whether to connect directly to Trend Micro's Smart Protection service:
 - a. Select **Connect directly to Global Smart Protection Service**.
 - b. Optionally select **When accessing Global Smart Protection Service, use proxy**. Select **New** from the drop down menu and enter your desired proxy.

Or to connect to one or more locally installed Smart Protection Servers:

- a. Select **Use locally installed Smart Protection Server (ex: "http://[server]:5274")**.
- b. Enter the Smart Protection Server URL into the field and click **Add**. To find the Smart Protection Server URL, do one of the following:
 - Log in to the Smart Protection Server, and in the main pane, look under **Real Time Status**. The Smart Protection Server's HTTP and HTTPS URLs are listed in the **Web Reputation** row. The HTTPS URL is only supported with 11.0 Deep Security Agents and up. If you have 10.3 or earlier agents, use the HTTP URL.

Or

- If you [deployed the Smart Protection Server in AWS](#), go to the AWS **CloudFormation** service, select the check box next to the Smart Protection Server stack, and in the bottom pane, click the **Outputs** tab. The Smart Protection Server's HTTP and HTTPS URLs appear in the **WRSurl** and **WRSHTTPSurl** fields. The WRSHTTPSurl is only supported with 11.0 Deep Security Agents and up. If you have 10.3 or earlier agents, use the WRSurl URL.
 - c. Optionally select **When off domain, connect to global Smart Protection Service (Windows only)**.
5. Click **Save**.

Smart Protection Server Connection Warning

This option determines whether or not error events are generated and alerts are raised if a computer loses its connection to the Smart Protection Server. Select either **Yes** or **No** and click **Save**.

Note: If you have a locally installed Smart Protection Server, this option should be set to **Yes** on at least one computer so that you are notified if there is a problem with the Smart Protection Server itself.

Edit advanced settings

Blocking Page

When users attempt to access a blocked URL, they are redirected to a blocking page. In the blank for **Link**, provide a link that users can use to request access to the blocked URL.

Alert

Decide to raise an alert when a web reputation event is logged by selecting either **Yes** or **No**.

Ports

Select specific ports to monitor for potentially harmful web pages from the drop down list next to **Ports to monitor for potentially harmful web pages**.

Test Web Reputation

Before continuing, test that the Web Reputation is working correctly:

1. Ensure Web Reputation is enabled.
2. Go to the **Computer or Policy editor > Web Reputation > Exceptions**.
3. Under **Blocked**, enter *http://www.speedtest.net* and click **Add**. Click **Save**.
4. Open a browser and attempt to access the website. A message denying the access should appear.
5. Go to **Events & Reports > Web Reputation** to verify the record of the denied web access. If the detection is recorded, the Web Reputation module is working correctly.

Configure Intrusion Prevention (IPS)

About Intrusion Prevention

The Intrusion Prevention module protects your computers from known and zero-day vulnerability attacks as well as against SQL injections attacks, cross-site scripting attacks, and other web application vulnerabilities.

When patches are not available for known vulnerabilities in applications or operating systems, Intrusion Prevention rules can intercept traffic that is trying to exploit the vulnerability. It identifies malicious software that is accessing the network and it increases visibility into, or control over, applications that are accessing the network. Therefore your computers are protected until patches that fix the vulnerability are released, tested, and deployed.

Protection is available for file sharing and messaging software such as Skype, but also web applications with vulnerabilities such as SQL injection and cross-site scripting (XSS). In this way, Intrusion Prevention can also be used as a lightweight web application firewall (WAF).

To enable and configure Intrusion Prevention, see "[Set up Intrusion Prevention](#)" on page 882.

Intrusion Prevention rules

Intrusion Prevention rules define a set of conditions that are compared to the payload session and application layers of network packets (such as DNS, HTTP, SSL, and SMTP), as well as the sequence of those packets according to those higher-layer protocols.

Tip: Firewall rules examine the network and transport layers of a packet (IP, TCP, and UDP, for example).

When Deep Security Agents scan network traffic and the traffic meets a rule's match conditions, the agent handles it as a possible or confirmed attack and performs one of the following actions, depending on the rule:

- Completely drop packets
- Reset the connection

Intrusion Prevention rules are assigned to policies and computers. Therefore you can enforce sets of rules on groups of computers based on the policy that they use, and override policies as required. (See "[Policies, inheritance, and overrides](#)" on page 701.)

For information about how you can affect the functionality of rules, see ["Configure intrusion prevention rules" on page 888](#).

Application types

Application types organize rules by the application that they are associated with. Application types can also store property values that rules can reference as required, such as protocols used for communications, and port numbers. Some application types have configurable properties. For example, the Database Microsoft SQL application type contains rules that are associated with Microsoft SQL Server. You can configure this application type to specify the ports used to connect to the database.

For more information, see ["Application types" on page 908](#).

Rule updates

Trend Micro creates Intrusion Prevention rules for application vulnerabilities as they are discovered. Security updates can include new or updated rules and application types. When a rule is already assigned to a policy, and an update includes rules upon which the assigned rule depends, you can choose to automatically assign the updated rules.

Tip: Intrusion Prevention rules from Trend Micro include information about the vulnerability against which it protects.

Intrusion Prevention rules from Trend Micro are not directly editable through Deep Security Manager. However some rules are configurable, and some rules require configuration. (See ["Setting configuration options \(Trend Micro rules only\)" on page 894](#).)

Recommendation scans

You can use recommendation scans to discover the Intrusion Prevention rules that you should assign to your policies and computers. (See ["Manage and run recommendation scans" on page 705](#).)

Use behavior modes to test rules

Intrusion Prevention works in either Detect or Prevent mode:

- **Detect:** Intrusion Prevention uses rules to detect matching traffic and generate events, but does not block traffic. Detect mode is useful to test that Intrusion Prevention rules do not interfere with legitimate traffic.

- **Prevent:** Intrusion Prevention uses rules to detect matching traffic, generate events, and block traffic to prevent attacks.

When you first apply new Intrusion Prevention rules, use Detect mode to verify that they don't accidentally block normal traffic (false positives). When you are satisfied that no false positives occur, you can use Prevent mode to enforce the rules and block attacks. (See ["Enable Intrusion Prevention in Detect mode" on page 882](#) and ["Switch to Prevent mode" on page 887](#).)

Tip: Similar to using Intrusion Prevention in Detect mode, the Deep Security network engine can run in tap mode for testing purposes. In tap mode, Intrusion Prevention detects rule-matching traffic and generates events, but doesn't block traffic. Also, tap mode affects the Firewall and Web Reputation modules. You can use Detect mode to test Intrusion Prevention rules separately.

You use tap mode with Intrusion Prevention in the same way that tap mode is used for testing Firewall rules. See ["Test Firewall rules before deploying them" on page 927](#).

Override the behavior mode for rules

By selecting Detect mode for individual rules, you can selectively override Prevent mode behavior set at the computer or policy level. This is useful for testing new Intrusion Prevention rules that are applied to a policy or computer. For example, when a policy is configured such that Intrusion Prevention works in Prevent mode, you can bypass the Prevent mode behavior for an individual rule by setting that rule to Detect mode. For that rule only, Intrusion Prevention merely logs the traffic, and enforces other rules that do not override the policy's behavior mode. (See ["Override the behavior mode for a rule" on page 896](#).)

Note: While Prevent mode at the computer or policy level can be overridden by contradictory rule settings, Detect mode cannot. Selecting Detect mode at the computer or policy level enforces Detect mode behavior regardless of rule settings.

Some rules issued by Trend Micro use Detect mode by default. For example, mail client rules generally use Detect mode because in Prevent mode they block the downloading of all mail. Some rules trigger an alert only when a condition occurs a large number of times, or a certain number of times within a certain period of time. These types of rules apply to traffic that constitutes suspicious behavior only when a condition recurs, and a single occurrence of the condition is considered normal.

Warning:

To prevent blocking legitimate traffic and interrupting network services, when a rule requires configuration, keep it in Detect mode until you've configured the rule. Switch a rule to Prevent mode only after configuration and testing.

Intrusion Prevention events

By default, the Deep Security Manager collects Firewall and Intrusion Prevention event logs from the Deep Security **Agents and Appliances**¹ at every heartbeat. Once collected by the Deep Security Manager, event logs are kept for a period of time which can be configured. The default setting is one week. (See ["Log and event storage best practices" on page 1129](#).) You can configure event logging for individual rules as required. (See ["Configure event logging for rules" on page 893](#).)

Event tagging can help you to sort events. You can manually apply tags to events or automatically tag them. You can also use the auto-tagging feature to group and label multiple events. For more information on event tagging, see ["Apply tags to identify and group events" on page 1136](#).

Support for secure connections

The Intrusion Prevention module supports inspecting packets over secure connections. See ["Inspect TLS traffic" on page 910](#).

Contexts

Contexts are a powerful way of implementing different security policies depending on the computer's network environment. You typically use contexts to create policies that apply different Firewall and Intrusion Prevention rules to computers (usually mobile laptops) depending on whether that computer is in the office or away.

To determine a computer's location, contexts examine the nature of the computer's connection to its domain controller. For more information, see ["Define contexts for use in policies" on page 790](#).

¹The Deep Security Agent and Deep Security Virtual Appliance are the components that enforce the Deep Security policies that you have defined. Agents are deployed directly on a computer. Appliances are used in VMware vSphere environments to provide agentless protection. They are not available with Deep Security as a Service.

Interface tagging

You can use interface types when you need to assign Firewall or Intrusion Prevention rules to a specific interface when a machine has multiple network interfaces. By default, Firewall and Intrusion Prevention rules are assigned to all interfaces on a computer. For example, to apply special rules only to the wireless network interface, use interface types to accomplish this. For more information, see ["Configure a policy for multiple interfaces" on page 716](#).

Set up Intrusion Prevention

Enable the Intrusion Prevention module and monitor network traffic for exploits using Detect mode. When you are satisfied with how your Intrusion Prevention rules are assigned, switch to Prevent mode.

1. ["Enable Intrusion Prevention in Detect mode" below](#)
2. ["Test Intrusion Prevention" on page 884](#)
3. ["Apply recommended rules" on page 885](#)
4. ["Monitor your system" on page 886](#)
5. ["Enable 'fail open' for packet or system failures" on page 887](#)
6. ["Switch to Prevent mode" on page 887](#)
7. ["Implement best practices for specific rules" on page 887](#)
8. ["Apply NSX security tags" on page 888](#)

Note: CPU usage and RAM usage varies by your IPS configuration. To optimize IPS performance on Deep Security Agent, see ["Performance tips for intrusion prevention" on page 924](#).

For an overview of the Intrusion Prevention module, see ["About Intrusion Prevention" on page 878](#).

Enable Intrusion Prevention in Detect mode

Enable Intrusion Prevention and use Detect mode for monitoring. Configure Intrusion Prevention using the appropriate policies to affect the targeted computers. You can also configure individual computers:

1. Go to **Computer or Policy editor**¹ > Intrusion Prevention > General.
2. For **Configuration**, select either **On** or **Inherited (On)**.

Computer: [Computer Name] Help

Overview | **General** | Advanced | Intrusion Prevention Events

Intrusion Prevention

Configuration: On

State: ● Intrusion Prevention Engine Offline

Intrusion Prevention Behavior

Prevent
 Detect

Advanced TLS Traffic Inspection ⓘ

Inspect TLS/SSL inbound traffic: Inherited (Yes)

Inspect TLS/SSL outbound traffic: Inherited (Yes)

Container Protection

Scan container network traffic: Inherited (Yes)

Assigned Intrusion Prevention Rules

All

Assign/Unassign... Properties... Export Application Types... Columns...

NAME ^	DESCRIPTION	APPLICATION TYPE	PRIORITY
1004715 - HTTP Web Client Decoding	This is a smart filter that decodes the We...	Web Client Common	1 - Low
1009218 - Microsoft Windows VBScript Engine Use-After-Free Vulnerability	Microsoft Windows VBScript Engine is pr...	Web Client Common	2 - Normal

Recommendations

Current Status: 2 Intrusion Prevention Rule(s) assigned

Last Scan for Recommendations: N/A

ⓘ No Recommendation Scan Results

Automatically implement Intrusion Prevention Recommendations (when possible): Default (No)

Scan For Recommendations Cancel Recommendation Scan Clear Recommendations

Save Close

3. For **Intrusion Prevention Behavior**, select **Detect**.
4. With Deep Security Agent 11.1 and earlier, the Intrusion Prevention module inspects traffic that passes through the host computer's network interface to containers. With Deep Security Agent 11.2 or later, it can also inspect traffic between containers. When the **Scan container network traffic** setting is set to **Yes**, Deep Security scans the traffic that goes through both containers and hosts. When it is set to **No**, Deep Security scans only the traffic that goes through the host network interface.
5. Click **Save**.

¹You can change these settings for a policy or for a specific computer. To change the settings for a policy, go to the Policies page and double-click the policy that you want to edit (or select the policy and click Details). To change the settings for a computer, go to the Computers page and double-click the computer that you want to edit (or select the computer and click Details).

Tip: If the behavior settings are not available, **Network Engine Mode** may be set to **Tap**. (See "[Test Firewall rules before deploying them](#)" on page 927.)

For more fine-grained control, when you assign Intrusion Prevention rules, you can override the global behavior mode and configure specific rules to either prevent or detect (see "[Override the behavior mode for a rule](#)" on page 896).

Test Intrusion Prevention

Before continuing, you should perform the following steps to verify that the Intrusion Prevention module is working properly:

1. If you have an agent-based deployment, make sure you have a computer that has an agent running. For an agentless deployment, make sure your Deep Security Virtual Appliance is running normally.
2. Disable the Web Reputation module. In Deep Security Manager, click **Computers**, then double-click the computer where you will test Intrusion Prevention. In the computer's dialog box, click **Web Reputation**, and select **Off**. Web Reputation is now disabled and won't interfere with the Intrusion Prevention functionality.
3. Make sure bad traffic is blocked. Still in the computer's dialog box, click **Intrusion Prevention**, and under the **General** tab, select **Prevent**. (If it is shaded, set the **Configuration** drop-down list to **Inherited (On)**.)
4. Assign the EICAR test policy. Still in the computer's dialog box, click **Intrusion Prevention**. Click **Assign/Unassign**. Search for `1005924`. The **1005924 - Restrict Download of EICAR Test File Over HTTP** policy appears. Select its check box and click **OK**. The policy is now assigned to the computer.
5. Try to download the EICAR file (you can't, if Intrusion Prevention is running properly). On Windows, go to this link: <http://files.trendmicro.com/products/eicar-file/eicar.com>. On Linux, enter this command: `curl -O http://files.trendmicro.com/products/eicar-file/eicar.com`
6. Check the Intrusion Prevention events for the computer. Still in the computer's dialog box, click **Intrusion Prevention > Intrusion Prevention Events**. Click **Get Events** to see events that have occurred since the last heartbeat. An event appears with a **Reason** of **1005924 - Restrict Download of EICAR Test File Over HTTP**. The presence of this event indicates that Intrusion Prevention is working.
7. Revert your changes to return your system to its previous state. Turn on the Web Reputation module (if you turned it off), reset the **Prevent** or **Detect** option, and remove the EICAR policy from the computer.

Apply recommended rules

To maximize performance, only assign the Intrusion Prevention rules that are required by your policies and computers. You can use a recommendation scan to obtain a list of rules that are appropriate.

Although recommendation scans are performed for a specific computer, you can assign the recommendations to a policy that the computer uses.

For more information, see ["Manage and run recommendation scans" on page 705](#).

1. Open the properties for the computer to scan. Run the recommendation scan as described in ["Manually run a recommendation scan" on page 710](#).

Note: You can configure Deep Security to ["Automatically implement recommendations" on page 711](#) scan results when it is appropriate to do so.

- Open the policy to which you want to assign the rules, and complete the rule assignments as described in ["Check scan results and manually assign rules"](#) on page 712.

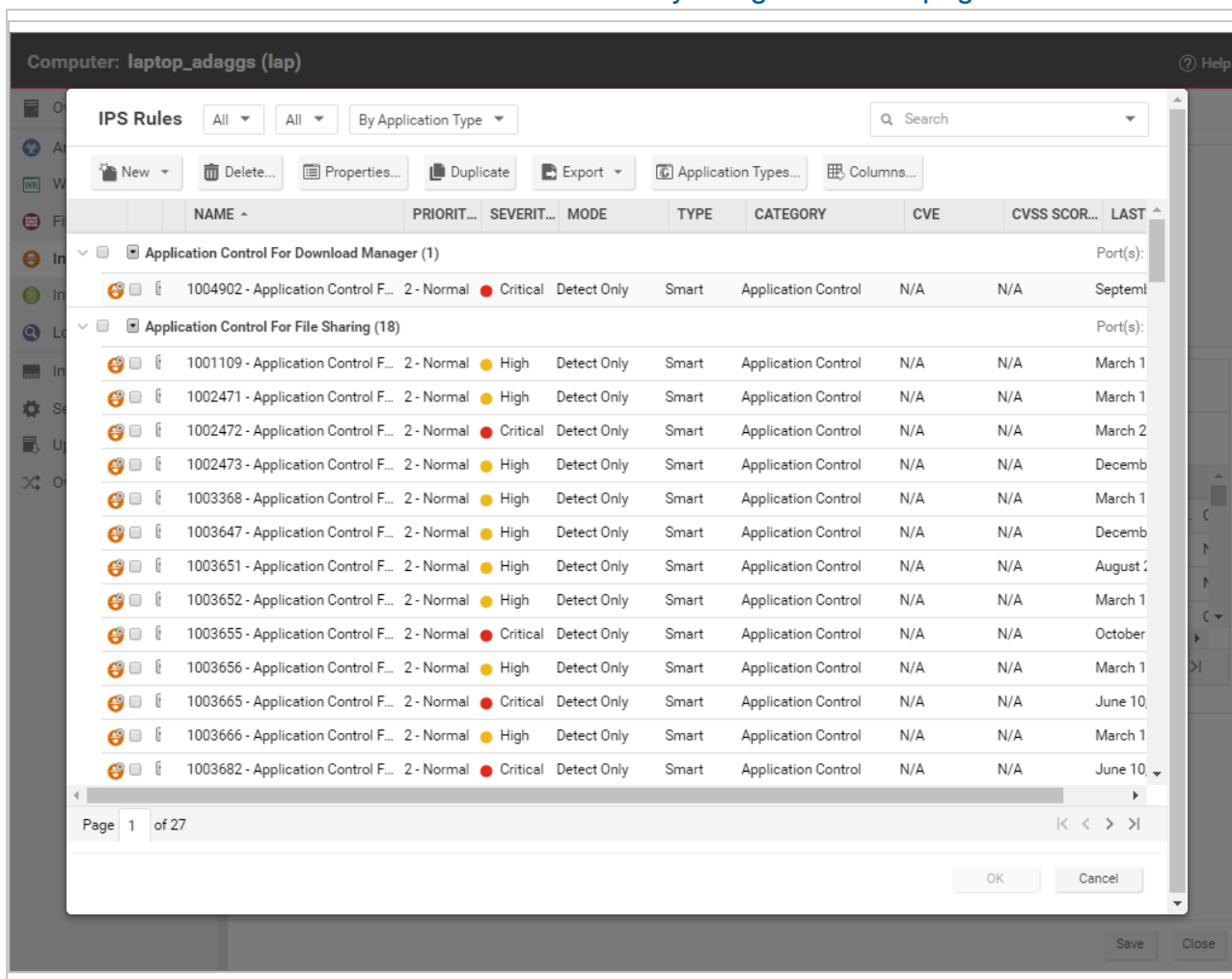

Tip: To automatically and periodically fine tune your assigned Intrusion Prevention rules, you can schedule recommendation scans. See ["Schedule Deep Security to perform tasks"](#) on page 1766.

Monitor your system

After you apply Intrusion Prevention rules, monitor system performance and Intrusion Prevention event logs.

Monitor system performance

Monitor CPU, RAM, and network usage to verify that system performance is still acceptable. If not, you can modify some settings and deployment aspects to improve performance (see

["Performance tips for intrusion prevention" on page 924](#)).

Check Intrusion Prevention events

Monitor Intrusion Prevention events to ensure that rules are not matching legitimate network traffic. If a rule is causing false positives you can unassign the rule. (See ["Assign and unassign rules" on page 892](#).)

To see Intrusion Prevention events, click **Events & Reports > Intrusion Prevention Events**.

Enable 'fail open' for packet or system failures

The Intrusion Prevention module includes a network engine that might block packets before Intrusion Prevention rules can be applied. This might lead to downtime or performance issues with your services and applications. You can change this behavior so that packets are allowed through when system or internal packet failures occur. For details, see ["Enable 'fail open' behavior" on page 929](#).

Switch to Prevent mode

When you are satisfied that Intrusion Prevention is not finding false positives, configure your policy to use Intrusion Prevention in Prevent mode so that rules are enforced and related events are logged, as follows:

1. Go to **Computer or Policy editor**¹ > **Intrusion Prevention > General**.
2. For **Intrusion Prevention Behavior**, select **Prevent**.
3. Click **Save**.

Implement best practices for specific rules

HTTP Protocol Decoding rule

The HTTP Protocol Decoding rule is the most important rule in the Web Server Common application type. This rule decodes the HTTP traffic before the other rules inspect it. This rule also allows you to control various components of the decoding process.

This rule is required when you use any of the Web Application Common or Web Server Common rules that require it. Deep Security Manager automatically assigns this rule when it is required by other rules. As each web application is different, the policy that uses this rule should

¹You can change these settings for a policy or for a specific computer. To change the settings for a policy, go to the Policies page and double-click the policy that you want to edit (or select the policy and click Details). To change the settings for a computer, go to the Computers page and double-click the computer that you want to edit (or select the computer and click Details).

run in Detect mode for a period of time before switching to Prevent mode to determine if any configuration changes are required.

Changes to the list of illegal characters are often required.

Refer to the following Knowledge Base articles for more details on this rule and how to tune it:

- <https://success.trendmicro.com/solution/1098016>
- <https://success.trendmicro.com/solution/1054481>
- <https://success.trendmicro.com/solution/1096566>

Cross-site scripting and generic SQL injection rules

Two of the most common application-layer attacks are SQL injection and cross-site scripting (XSS). Cross-site scripting and SQL injection rules intercept the majority of attacks by default, but you may need to adjust the drop score for specific resources if they cause false positives.

Both rules are smart filters that need custom configuration for web servers. If you have output from a Web Application Vulnerability Scanner, you should leverage that information when applying protection. For example, if the user name field on the login.asp page is vulnerable to SQL injection, ensure that the SQL injection rule is configured to monitor that parameter with a low threshold to drop on.

For more information, see <https://success.trendmicro.com/solution/1098159>

Apply NSX security tags

Apply NSX security tags

Deep Security can apply NSX security tags to protected VMs when Intrusion Prevention rules are triggered. For details, see "[Configure Intrusion Prevention to apply NSX security tags](#)" on page 625.

Configure intrusion prevention rules

Perform the following tasks to configure and work with intrusion prevention rules:

- "[See the list of intrusion prevention rules](#)" on the next page
- "[See information about an intrusion prevention rule](#)" on the next page
- "[See information about the associated vulnerability \(Trend Micro rules only\)](#)" on page 891
- "[Assign and unassign rules](#)" on page 892

- ["Automatically assign updated required rules" on page 892](#)
- ["Configure event logging for rules" on page 893](#)
- ["Generate alerts" on page 894](#)
- ["Setting configuration options \(Trend Micro rules only\)" on page 894](#)
- ["Schedule active times" on page 894](#)
- ["Exclude from recommendations" on page 895](#)
- ["Set the context for a rule" on page 895](#)
- ["Override the behavior mode for a rule" on page 896](#)
- ["Override rule and application type configurations" on page 896](#)
- ["Export and import rules" on page 897](#)
- ["Configure an SQL injection prevention rule" on page 897](#)

For an overview of the intrusion prevention module, see ["About Intrusion Prevention" on page 878](#).

See the list of intrusion prevention rules

The Policies page provides a list of intrusion prevention rules. You can search for intrusion prevention rules, and open and edit rule properties. In the list, rules are grouped by application type, and some rule properties appear in different columns.

Tip: The "TippingPoint" column contains the equivalent Trend Micro TippingPoint rule ID. In the Advanced Search for intrusion prevention, you can search on the TippingPoint rule ID. You can also see the TippingPoint rule ID in the list of assigned intrusion prevention rules in the policy and computer editor.

To see the list, click **Policies**, and then below **Common Objects/Rules** click **Intrusion Prevention Rules**.

See information about an intrusion prevention rule



The properties of intrusion prevention rules include information about the rule and the exploit against which it protects.

1. Click **Policies > Intrusion Prevention Rules**.
2. Select a rule and click **Properties**.

General Information

- **Name:** The name of the intrusion prevention rule.
- **Description:** The description of the intrusion prevention rule.
- **Minimum Agent/Appliance Version:** The minimum version of the Deep Security **Agent or Appliance**¹ required to support this intrusion prevention rule.

Details

Clicking **New** () or **Properties** () displays the **Intrusion Prevention Rule Properties** window.

Note: Note the **Configuration** tab. Intrusion Prevention Rules from Trend Micro are not directly editable through Deep Security Manager. Instead, if the Intrusion Prevention Rule requires (or allows) configuration, those configuration options will be available on the **Configuration** tab. Custom Intrusion Prevention Rules that you write yourself will be editable, in which case the **Rules** tab will be visible.

See the list of intrusion prevention rules

The Policies page provides a list of intrusion prevention rules. You can search for intrusion prevention rules, and open and edit rule properties. In the list, rules are grouped by application type, and some rule properties appear in different columns.

Tip: The "TippingPoint" column contains the equivalent Trend Micro TippingPoint rule ID. In the Advanced Search for intrusion prevention, you can search on the TippingPoint rule ID. You can also see the TippingPoint rule ID in the list of assigned intrusion prevention rules in the policy and computer editor.

To see the list, click **Policies**, and then below **Common Objects/Rules** click **Intrusion Prevention Rules**.

¹The Deep Security Agent and Deep Security Virtual Appliance are the components that enforce the Deep Security policies that you have defined. Agents are deployed directly on a computer. Appliances are used in VMware vSphere environments to provide agentless protection. They are not available with Deep Security as a Service.

General Information

- **Application Type:** The application type under which this intrusion prevention rule is grouped.

Tip: You can edit application types from this panel. When you edit an application type from here, the changes are applied to all security elements that use it.

- **Priority:** The priority level of the rule. Higher priority rules are applied before lower priority rules.
- **Severity:** Setting the severity of a rule has no effect on how the rule is implemented or applied. Severity levels can be useful as sorting criteria when viewing a list of intrusion prevention rules. More importantly, each severity level is associated with a severity value; this value is multiplied by a computer's Asset Value to determine the Ranking of an Event. (See **Administration > System Settings > Ranking.**)
- **CVSS Score:** A measure of the severity of the vulnerability according the [National Vulnerability Database](#).

Identification (Trend Micro rules only)

- **Type:** Can be either Smart (one or more known and unknown (zero day) vulnerabilities), Exploit (a specific exploit, usually signature based), or Vulnerability (a specific vulnerability for which one or more exploits may exist).
- **Issued:** The date the rule was released. This does not indicate when the rule was downloaded.
- **Last Updated:** The last time the rule was modified either locally or during Security Update download.
- **Identifier:** The rule's unique identification tag.

See information about the associated vulnerability (Trend Micro rules only)

Rules that Trend Micro provides can include information about the vulnerability against which the rule protects. When applicable, the Common Vulnerability Scoring System (CVSS) is displayed. (For information on this scoring system, see the CVSS page at the [National Vulnerability Database](#).)

1. Click **Policies > Intrusion Prevention Rules**.
2. Select a rule and click **Properties**.
3. Click the **Vulnerabilities** tab.

Assign and unassign rules

To apply intrusion prevention rules during agent scans, you assign them to the appropriate policies and computers. When the rule is no longer necessary because the vulnerability has been patched you can unassign the rule.

If you cannot unassign intrusion prevention rules from a **Computer editor**¹, it is likely because the rules are currently assigned in a policy. Rules assigned at the policy level must be removed using the **Policy editor**² and cannot be removed at the computer level.

When you make a change to a policy, it affects all computers using the policy. For example, when you unassign a rule from a policy you remove the rule from all computers that are protected by that policy. To continue to apply the rule to other computers, create a new policy for that group of computers. (See "[Policies, inheritance, and overrides](#)" on page 701.)

Tip: To see the policies and computers to which a rule is assigned, see the Assigned To tab of the rule properties.

1. Go to the **Policies** page, right-click the policy to configure and click **Details**.
2. Click **Intrusion Prevention > General**.
The list of rules that are assigned to the policy appear in the **Assigned Intrusion Prevention Rules** list.
3. Under **Assigned Intrusion Prevention Rules**, click **Assign/Unassign**.
4. To assign a rule, select the check box next to the rule.
5. To unassign a rule, deselect the check box next to the rule.
6. Click **OK**.

Automatically assign updated required rules

Security updates can include new or updated application types and intrusion prevention rules which require the assignment of secondary intrusion prevention rules. Deep Security can automatically assign these rules if they are required. You enable these automatic assignments in the the policy or computer properties.

1. Go to the **Policies** page, right-click the policy to configure and click **Details**.
2. Click **Intrusion Prevention > Advanced**.

¹To open the Computer editor, go to the Computers page and double-click the computer that you want to edit (or select the computer and click Details).

²To open the Policy editor, go to the Policies page and double-click the policy that you want to edit (or select the policy and click Details).

3. To enable the automatic assignments, in the **Rule Updates** area, select **Yes**.
4. Click **OK**.

Configure event logging for rules

Configure whether events are logged for a rule, and whether to include packet data in the log.

Note: Deep Security can display X-Forwarded-For headers in intrusion prevention events when they are available in the packet data. This information can be useful when the Deep Security Agent is behind a load balancer or proxy. The X-Forwarded-For header data appears in the event's Properties window. To include the header data, include packet data in the log. In addition, rule 1006540 " Enable X-Forwarded-For HTTP Header Logging" must be assigned.

Because it would be impractical to record all packet data every time a rule triggers an event, Deep Security records the data only the first time the event occurs within a specified period of time. The default time is five minutes, however you can change the time period using the "Period for Log only one packet within period" property of a policy's Advanced Network Engine settings. (See [Advanced Network Engine Options](#).)

The configuration performed in the following procedure affects all policies. For information about configuring a rule for one policy, see "[Override rule and application type configurations](#)" on [page 896](#).

1. Click **Policies > Intrusion Prevention Rules**.
2. Select a rule and click **Properties**.
3. On the General tab, go to the Events area and select the desired options:
 - To disable logging for the rule, select **Disable Event Logging**.
 - To log an event when a packet is dropped or blocked, select **Generate Event on Packet Drop**.
 - To include the packet data in the log entry, select **Always Include Packet Data**.
 - To log several packets that precede and follow the packet that the rule detected, select **Enable Debug Mode**. Use debug mode only when your support provider instructs you to do so.

Additionally, to include packet data in the log, the policy to which the rule is assigned must allow rules to capture packet data:

1. On the Policies page, open the policy that is assigned the rule.
2. Click **Intrusion Prevention > Advanced**.
3. In the **Event Data** area, select **Yes**.

Generate alerts

Generate an alert when an intrusion prevention rule triggers an event.

The configuration performed in the following procedure affects all policies. For information about configuring a rule for one policy, see ["Override rule and application type configurations" on page 896](#).

1. Click **Policies > Intrusion Prevention Rules**.
2. Select a rule and click **Properties**.
3. Click the **Options** tab, and in the **Alert** area select **On**.
4. Click **OK**.

Setting configuration options (Trend Micro rules only)

Some intrusion prevention rules that Trend Micro provides have one or more configuration options such as header length, allowed extensions for HTTP, or cookie length. Some options require you to configure them. If you assign a rule without setting a required option, an alert is generated that informs you about the required option. (This also applies to any rules that are downloaded and automatically applied by way of a Security Update.)

Intrusion prevention rules that have configuration options appear in the Intrusion Prevention Rules list with a small gear over their icon .

Note: Custom intrusion prevention rules that you write yourself include a **Rules** tab where you can edit the rules.

The configuration performed in the following procedure affects all policies. For information about configuring a rule for one policy, see ["Override rule and application type configurations" on page 896](#).

1. Click **Policies > Intrusion Prevention Rules**.
2. Select a rule and click **Properties**.
3. Click the **Configuration** tab.
4. Configure the properties and then click **OK**.

Schedule active times

Schedule a time during which an intrusion prevention rule is active. Intrusion prevention rules that are active only at scheduled times appear in the Intrusion Prevention Rules page with a small clock over their icon .

Note: With Agent-based protection, schedules use the same time zone as the endpoint operating system. With Agentless protection, schedules use the same time zone as the Deep Security Virtual Appliance.

The configuration performed in the following procedure affects all policies. For information about configuring a rule for one policy, see ["Override rule and application type configurations" on the next page](#).

1. Click **Policies > Intrusion Prevention Rules**.
2. Select a rule and click **Properties**.
3. Click the **Options** tab.
4. In the **Schedule** area, select **New** or select a frequency.
5. Edit the schedule as required.
6. Click **OK**.

Exclude from recommendations

Exclude intrusion prevention rules from rule recommendations of recommendation scans.

The configuration performed in the following procedure affects all policies. For information about configuring a rule for one policy, see ["Override rule and application type configurations" on the next page](#).

1. Click **Policies > Intrusion Prevention Rules**.
2. Select a rule and click **Properties**.
3. Click the **Options** tab.
4. In the **Recommendations Options** area, select **Exclude from Recommendations**.
5. Click **OK**.

Set the context for a rule

Set the context in which the rule is applied.

The configuration performed in the following procedure affects all policies. For information about configuring a rule for one policy, see ["Override rule and application type configurations" on the next page](#).

1. Click **Policies > Intrusion Prevention Rules**.
2. Select a rule and click **Properties**.
3. Click the **Options** tab.
4. In the **Context** area, select **New** or select a context.

5. Edit the context as required.
6. Click **OK**.

Override the behavior mode for a rule

Set the behavior mode of an intrusion prevention rule to Detect when testing new rules. In Detect mode, the rule creates a log entry prefaced with the words "detect only:" and does not interfere with traffic. Some intrusion prevention rules are designed to operate only in Detect mode. For these rules, you cannot change the behavior mode.

Note: If you disable logging for the rule, the rule activity is not logged regardless of the behavior mode.

For more information about behavior modes, see ["Use behavior modes to test rules" on page 879](#).

The configuration performed in the following procedure affects all policies. For information about configuring a rule for one policy, see ["Override rule and application type configurations" below](#).

1. Click **Policies > Intrusion Prevention Rules**.
2. Select a rule and click **Properties**.
3. Select **Detect Only**.

Override rule and application type configurations

From a **Computer or Policy editor**¹, you can edit an intrusion prevention rule so that your changes apply only in the context of the policy or computer. You can also edit the rule so that the changes apply globally so that the changes affect other policies and computers that are assigned the rule. Similarly, you can configure application types for a single policy or computer, or globally.

1. Go to the **Policies** page, right-click the policy to configure and click **Details**.
2. Click **Intrusion Prevention**.
3. To edit a rule, right-click the rule and select one of the following commands:
 - **Properties**: Edit the rule only for the policy.
 - **Properties (Global)**: Edit the rule globally, for all policies and computers.

¹You can change these settings for a policy or for a specific computer. To change the settings for a policy, go to the Policies page and double-click the policy that you want to edit (or select the policy and click Details). To change the settings for a computer, go to the Computers page and double-click the computer that you want to edit (or select the computer and click Details).

4. To edit the application type of a rule, right-click the rule and select one of the following commands:
 - **Application Type Properties:** Edit the application type only for the policy.
 - **Application Type Properties (Global):** Edit the application type globally, for all policies and computers.
5. Click **OK**.

Tip: When you select the rule and click Properties, you are editing the rule only for the policy that you are editing.

Note: You cannot assign one port to more than eight application types. If they are, the rules will not function on that port.

Export and import rules

You can export one or more intrusion prevention rules to an XML or CSV file, and import rules from an XML file.

1. Click **Policies > Intrusion Prevention Rules**.
2. To export one or more rules, select them and click **Export > Export Selected to CSV** or **Export > Export Selected to XML**.
3. To export all rules, click **Export > Export to CSV** or **Export > Export to XML**.
4. To import rules, click **New > Import From File** and follow the instructions on the wizard.

Configure an SQL injection prevention rule

Deep Security's intrusion prevention module includes a built-in rule that detects SQL injection attacks and drops the connection or logs it depending on its characteristics. The rule is called **1000608 - Generic SQL Injection Prevention** and can be configured to suit your organization's needs. For example, you can change the sensitivity of the rule by modifying the drop threshold.

The screenshot shows the Trend Micro Deep Security interface. The top navigation bar includes 'Dashboard', 'Actions', 'Alerts', 'Events & Reports', 'Computers', 'Policies', and 'Administration'. The left sidebar shows a tree view with 'Policies' expanded to 'Intrusion Prevention Rules'. The main content area displays 'IPS Rules' with a table of rules. The rule '1000608 - Generic SQL Injection Prevention' is highlighted in a red box. The table columns are NAME, PRIORI..., SEVERI..., MODE, TYPE, CATEGORY, and CVE. The rule details are: NAME: 1000608 - Generic SQL Injection Prevention, PRIORI...: 1 - Low, SEVERI...: Critical, MODE: Prevent, TYPE: Smart, CATEGORY: Web Application Prot..., CVE-2...

NAME	PRIORI...	SEVERI...	MODE	TYPE	CATEGORY	CVE
Web Application Common (1)						
1000608 - Generic SQL Injection Prevention	1 - Low	Critical	Prevent	Smart	Web Application Prot...	CVE-2...

Topics in this article:

- ["What is an SQL injection attack?" below](#)
- ["What are common characters and strings used in SQL injection attacks?" below](#)
- ["How does the Generic SQL Injection Prevention rule work?" on page 900](#)
- ["Examples of the rule and scoring system in action" on page 901](#)
- ["Configure the Generic SQL Injection Prevention rule" on page 903](#)
- ["Character encoding guidelines" on page 906](#)

What is an SQL injection attack?

An SQL injection attack, or SQL phishing attack, is a method of attacking data-driven applications wherein an attacker includes portions of SQL statements in an entry field. The newly-formed rogue SQL command is passed by the website to your database where it is executed. The command can result in the attacker being able to read, add, delete, or change information in the database.

What are common characters and strings used in SQL injection attacks?

Here are some commonly used characters and strings. The list is not exhaustive.

- (
- %27
- \x22
- %22
- char
- ;
- ascii
- %3B
- %2B
- --
- %2D%2D
- /*
- %2F%2A
- */
- %2A%2F
- substring

- drop table
- drop+table
- insert into
- insert+into
- version(
- values
- group by
- group+by
- create table
- create+table
- delete
- update
- bulk insert
- bulk+insert
- load_file
- shutdown
- union
- having
- select
- declare
- exec
- and
- or
- like
- @@hostname
- @@tmpdir
- is null
- is+null
- is not null
- is+not+null
- %3D

- CONCAT
- %40%40basedir
- version%28,user(
- user%28,system_user(
- (,%28,)
- %29
- @
- %40
- cast

How does the Generic SQL Injection Prevention rule work?

To detect SQL injection attacks, the Generic SQL Injection Prevention rule uses a scoring system. It works like this:

1. Packets from your application arrive at the Deep Security Agent for analysis.
2. The Generic SQL Injection Prevention rule looks at the packets and determines whether any of the strings shown in the table below are present. Notice that the strings are separated by commas and divided into ten groups.
3. If strings are found, a score is calculated as follows:
 - If a single string is found, then the score associated with its group constitutes the total score.
 - If multiple strings are found in *different* groups, then the scores of those groups are added together.
 - If multiple strings are found in the *same* group, then the score of that group is counted only once.See ["Examples of the rule and scoring system in action" on the next page](#) for clarification.
4. Using the total score, Deep Security determines whether to drop the connection or log it. If the total score exceeds the **Drop Threshold** score, then the connection is dropped, and if it exceeds the **Log Threshold** score, then it is logged.

Note: Trend Micro frequently updates its rules, so the strings in the table below might not match exactly the ones in Deep Security Manager.

Note: The use of '\w' in the lines below means 'followed by a non-alphanumeric character'.

Group	Score
drop table,drop+table,insert into,insert+into,values\W,create table,create+table,delete\W,update\W,bulk insert,bulk+insert,shutdown\W,from\W	2
declare\W,select\W	2
cast\W,exec\W,load_file	2
union\W,group by,group+by,order by,order+by,having\W	2
and\W,or\W,like\W,is null,is+null,is not null,is+not+null,where\W	1
--,%2D%2D,/*,%2F%2A,*!,%2A%2F	1
',%27,\x22,%22,char\W	1
;%3B	1
%2B,CONCAT\W	1
%3D	1
(,%28,)%29,@,%40	1
ascii,substring	1
version(,version%28,user(,user%28,system_user(,system_user%28,database(,database%28,@@hostname,%40%40hostname,@@basedir,%40%40basedir,@@tmpdir,%40%40tmpdir,@@datadir,%40%40datadir	2

Examples of the rule and scoring system in action

Below are some examples of how the scores are tallied and what actions are undertaken in each scenario.

Example 1: Logged and dropped traffic

Let's assume you are using this rule configuration (where the score for the group comes after the colon (":")):

```
drop table,drop+table,insert into,insert+into,values\W,create
table,create+table,delete\W,update\W,bulk
insert,bulk+insert,shutdown\W,from\W:2
declare\W,select\W:2
cast\W,exec\W,load_file:2
union\W,group by,group+by,order by,order+by,having\W:2
and\W,or\W,like\W,is null,is+null,is not null,is+not+null,where\W:1
--, %2D%2D, /*, %2F%2A, */, %2A%2F:1
', %27, \x22, %22, char\W:1
;, %3B:1
%2B, CONCAT\W:1
%3D:1
(, %28, ), %29, @, %40:1
ascii, substring:1
version(, version%28, user(, user%28, system_user(, system_user%28, databas
(, database%28, @@hostname, %40%40hostname, @@basedir, %40%40basedir, @@tmpdir, %
40%40tmpdir, @@datadir,
%40%40datadir:2

Log Threshold: 3
Drop Threshold: 4
```

And this attack string is encountered:

```
productID=BB10735166+UNION/**/+SELECT+FROM+user
```

Then the total score is 5 (2+1+0+2) because:

- The string `UNION/` matches the fourth group for a score of 2.
- The string `/*` matches the sixth group for a score of 1.
- The string `*/` matches the sixth group for a score of 0 (because the score of the sixth group has already been counted).
- The string `SELECT+` matches the second group for a score of 2.

With a total score of 5, a log is generated and the traffic is dropped.

Example 2: No logged or dropped traffic

Let's assume you are using this rule configuration (where the `select\W` string has been moved to the same line as `union\W`):

```
drop table,drop+table,insert into,insert+into,values\W,create
table,create+table,delete\W,update\W,bulk
insert,bulk+insert,shutdown\W,from\W:2
declare\W:2
cast\W,exec\W,load_file:2
union\W,select\W,group by,group+by,order by,order+by,having\W:2
and\W,or\W,like\W,is null,is+null,is not null,is+not+null,where\W:1
--, %2D%2D, /*, %2F%2A, */, %2A%2F:1
', %27, \x22, %22, char\W:1
;, %3B:1
%2B, CONCAT\W:1
%3D:1
(, %28, ), %29, @, %40:1
ascii, substring:1
version(, version%28, user(, user%28, system_user(, system_user%28, databas
(, database%28, @@hostname, %40%40hostname, @@basedir, %40%40basedir, @@tmpdir,
%40%40tmpdir, @@datadir, %40%40datadir:2

Log Threshold: 3
Drop Threshold: 4
```

And this attack string is encountered:

```
productID=BB10735166+UNION/**/+SELECT+FROM+user
```

Then the total score is 3 (2+1+0+0) because:

- The string `UNION/` matches the fourth group for a score of 2.
- The string `/*` matches the sixth group for a score of 1.
- The string `*/` matches the sixth group for a score of 0 (because the score of the sixth group has already been counted).
- The string `SELECT+` matches the fourth group for a score of 0 (because the score of the fourth group has already been counted).

With a total score of 3, no log is generated and no traffic is dropped. The score must *exceed* the thresholds for them to take effect.

Configure the Generic SQL Injection Prevention rule

You can configure the Generic SQL Injection Prevention rule to suit your organization's needs. The configurable options are shown in the image below.

Generic SQL Injection Prevention Properties - Microsoft Edge

app.deepsecurity.trendmicro.com/com.trendmicro.ds.network--PayloadFilter2Proj

General Vulnerability Details **Configuration** Options Assigned To

Configuration Options

SQL Injection Patterns. One group per line separated by ';'. The score for the group is at the end of the line after ':'. For ';' use \x2c and for '"' use \x22. The Maximum number of groups is 32.
eg. script, object, embed:2

```
drop table,drop+table,insert  
into,insert+into,values\W,create  
table,create+table,delete\W,update\W,bulk  
insert,bulk+insert,shutdown\W,from\W:2  
declare\W,select\W:2
```

Drop Threshold (if the score exceeds this value, the connection will be dropped):

Log Threshold (if the score exceeds this value, a log will be generated):

Max distance between matches (if this many characters go by without seeing a pattern in any group, the score is reset to 0):

Note: If Log Threshold is greater or equal to Drop Threshold then only Drop events will be generated. In the default configuration both are equal.

Pages (resource) with a non-default score to drop on. The score for each resource is at the end of the line after ':'. eg. /index.html:5 : (One per line)

```
/example/questionnaire.html:8
```

Form parameters with a non-default score to drop on. Each line begins with the resource name followed by the resource parameters separated by a ':'. The score for each parameter is set at the end of the parameter after '='.
eg. /index.html:userid=5,passwd=7 (One per line).

```
/example/login.html:username=10
```

View Rules...

OK Cancel Apply

To configure the rule:

1. Log in to Deep Security Manager.
 2. At the top, click **Policies**.
 3. In the search box on the right, enter `1000608` which is the Generic SQL Injection Prevention rule's numeric identifier. Press Enter. The rule appears in the main pane.
 4. Double-click the rule.
 5. Click the **Configuration** tab. You see the SQL injection pattern in the text box at the top.
 6. Update the SQL injection pattern with the latest version, if you haven't customized it yet. To update to the latest pattern, go to the **Details** tab, copy the text under the **Default SQL Pattern** heading and paste it into the **SQL Injection Patterns** text box on the **Configuration** tab. You are now working with the most up-to-date pattern from Trend Micro.
 7. Edit the fields as follows:
 - **SQL Injection Patterns:** This is where you to specify the list of characters and strings used in SQL injection attacks. Characters and strings are grouped and assigned a score. If you want to add or change the strings, make sure to use the proper encoding. See "[Character encoding guidelines](#)" on the next page below for details.
 - **Drop Threshold:** This is where you specify the drop score. The connection is dropped when the score exceeds this threshold. (If the score equals the drop threshold, the connection is maintained.) The default is `4`.
 - **Log Threshold:** This is where you specify the log score. The connection is logged when the score exceeds this threshold. (If the score equals the log threshold, nothing is logged.) The default is `4`.
 - **Max distance between matches:** This is where you specify the number of bytes that can pass without a match to reset the score to `0`. The default is `35`.
- **Note:** Consider using the next two options to create overrides for pages and fields that might cause the normal thresholds to be exceeded.
- **Pages (resource) with a non-default score to drop on:** This is where you can override the **Drop Threshold** for specific resources. For example, if your **Drop Threshold** is `4`, but you want a drop score of `8` for a questionnaire page, specify `/example/questionnaire.html:8`. With this configuration, `/example/questionnaire.html` needs to have a score *higher than* `8` in order for the connection to be dropped, while all other resources only need a score higher than `4`. Specify each resource on a separate line.
 - **Form parameters with a non-default score to drop on:** This is where you can override the thresholds defined in **Drop Threshold** or the **Pages (resources)with a non-default**

score to drop on fields for specific form fields. For example, if your **Drop Threshold** score is `4`, but you want a higher drop score of `10` for a username field, specify `/example/login.html:username=10`, where `/example/login.html` is replaced with the path and name of the page where the username field appears, and `username` is replaced with the username field used by your application. With this configuration, the username field needs to have a score *higher than* `10` for the connection to be dropped, while the page itself only needs a score higher than `4`. Specify each form field on a separate line.

Note: The **Log Threshold** does not take effect when connections are dropped due to a match on the **Pages (resources) with a non-default score to drop on** or **Form parameters with a non-default score to drop on** fields. For example, if you set the form parameter field to `/example/login.html:username=10`, and the username field scores `11`, the connection is dropped but there is no log of this event.

8. Click **OK**.

You have now configured the Generic SQL Injection Prevention rule.

Character encoding guidelines

If you want to change or add strings to the Generic SQL Injection Prevention rule, you must encode them properly. For example, if you want to use the quote character `'` in your pattern, you must enter `\x22`.

The table below shows characters and their encoded equivalents, as well as character classes that you can use to denote extended patterns.

Enter this string...	To denote...
<code>\a</code>	alphabetic characters, a-z A-Z
<code>\A</code>	non-alphabetic characters
	example: <code>delete\a</code> means "the word 'delete' followed by alphabetical characters"
<code>\w</code>	alphanumeric characters, a-z A-Z 0-9
<code>\W</code>	non-alphanumeric characters

Enter this string...	To denote...
	example: <code>delete\W</code> means "the word 'delete' followed by non-alphanumeric characters"
\d \D	digits 0-9 non-digit characters example: <code>delete\d</code> means "the word 'delete' followed by digits between zero and nine"
\s \S	whitespace not whitespace [<code>r,n,t,0x32</code>] example: <code>delete\S</code> means "the word 'delete' followed by non-whitespace"
\p \P	punctuation character, printable ascii other than above non-punctuation character example: <code>delete\p</code> means "the word 'delete' followed by a punctuation character or printable ascii"
\c \C	control character, below 32, or greater than or equal to 127, not including whitespace non-control character You can find details on control characters here .
\.	any
\xDD	hex byte 0xDD
\x2c	comma character (,)
\x22	double-quotes character (")
\\	escaped backslash (\)

Enter this string...	To denote...
\	escaped pipe ()
xx xx xx...	hex pipe (byte sequence)

Application types

The applications defined by Application Types are identified by the direction of traffic, the protocol being used, and the port number through which the traffic passes. Application Types are useful for grouping intrusion prevention rules that have a common purpose. Rule groups simplify the process of selecting a set of intrusion prevention rules to assign to a computer. For example, consider the set of rules required to protect HTTP traffic to an Oracle Report Server. Simply select the rules in the "Web Server Common" and "Web Server Oracle Report Server" application types and then exclude unneeded rules, such as the rules that are specific to IIS servers.

See a list of application types

Open the list of application types where you can see the properties of existing application types, as well as configure, export, and duplicate them. You can export to XML or CSV files. You can import XML files. You can also create and delete application types.

1. Click **Policies > Intrusion Prevention Rules**.
2. Click **Application Types**.
3. To apply a command to an application type, select the type and click the appropriate button.

Tip: Application types that have configurable properties have an icon with a gear. 

See also ["Override rule and application type configurations" on page 896](#).

General Information

The name and description of the Application Type. "Minimum Agent/Appliance Version" tells you what version of the Deep Security **agent or appliance**¹ is required to support this Application Type.

Connection

- **Direction:** The direction of the initiating communication. That is, the direction of the first packet that establishes a connection between two computers. For example, if you wanted to define an Application Type for Web browsers, you would select "Outgoing" because it is the Web browser that sends the first packet to a server to establish a connection (even though you may only want to examine traffic traveling from the server to the browser). The Intrusion Prevention Rules associated with a particular Application Type can be written to examine individual packets traveling in either direction.
- **Protocol:** The protocol this Application Type applies to.
- **Port:** The port(s) this Application Type monitors. (*Not* the port(s) over which traffic is exclusively allowed.)

Configuration

The **Configuration** tab displays options that control how Intrusion Prevention Rules associated with this Application Type behave. For example, the "Web Server Common" Application Type has an option to "Monitor responses from Web Server". If this option is deselected, Intrusion Prevention Rules associated with this Application Type will not inspect response traffic.

Options

Items in the **Options** tab control how the Deep Security Manager uses and applies the Application Type. For example, most Application Types have an option to exclude them from Recommendation Scans. This means that if the "Exclude from Recommendations" options is selected, a Recommendation Scan will not recommend this Application Type and its associated Intrusion Prevention Rules for a computer even if the application in question is detected.

Assigned To

The **Assigned To** tab lists the Intrusion Prevention Rules associated with this Application Type.

¹The Deep Security Agent and Deep Security Virtual Appliance are the components that enforce the Deep Security policies that you have defined. Agents are deployed directly on a computer. Appliances are used in VMware vSphere environments to provide agentless protection. They are not available with Deep Security as a Service.

Inspect TLS traffic

You can enable Advanced TLS Traffic Inspection for the [intrusion prevention module](#).

Note:

Advanced TLS Traffic Inspection and SSL Inspection do not support compressed traffic.

On this page:

- [Enable Advanced TLS Traffic Inspection](#)
- [Use Advanced TLS Traffic Inspection to inspect traffic](#)
- "Configure SSL inspection (legacy)" on the next page
- "Change port settings" on page 912
- "Use Intrusion Prevention when traffic is encrypted with Perfect Forward Secrecy (PFS)" on page 912
- [Supported cipher suites](#)
- "Supported protocols" on page 919

Enable Advanced TLS Traffic Inspection

Advanced TLS Traffic Inspection offers the following benefits over the legacy SSL inspection implementation:

- It removes the need to configure TLS credentials manually.
- It supports more ciphers than SSL inspection, including Perfect Forward Secrecy (PFS) ciphers. For more information, see [Supported cipher suites](#).

When the Intrusion Prevention module is enabled, Advanced TLS Traffic Inspection for inbound traffic is enabled by default, whereas it is disabled for outbound traffic. To verify the status, navigate to **Policy > Intrusion Prevention > General > Advanced TLS Traffic Inspection**.

Use Advanced TLS Traffic Inspection for inbound and outbound traffic

Advanced TLS Traffic Inspection can be enabled and used for inbound and outbound traffic on Windows and Linux platforms (see [Supported features by platform](#)).

On Windows, Advanced TLS Traffic Inspection only supports traffic using Windows-native TLS communication channels (see [Secure Channel](#)). For example, traffic produced by IIS, Microsoft Exchange, and Remote Desktop Protocol (RDP) is inspected.

On Linux, Advanced TLS Traffic Inspection only supports traffic by popular web applications: NGINX, Apache HTTP Server, and HAProxy.

Note:

If you need to inspect TLS traffic that is not supported by Advanced TLS Traffic Inspection, or TLS traffic on other operating systems, you can [configure the legacy SSL inspection](#) instead.

Configure SSL inspection (legacy)

You can configure SSL inspection for a given credential-port pair on one or more interfaces of your protected computer.

Credentials can be imported in PKCS#12 or PEM format. The credential file must include the private key. Windows computers can use CryptoAPI directly.

1. In Deep Security Manager, select the computer to configure and click **Details** to open the computer editor.
2. In the left pane of the computer editor, click **Intrusion Prevention > Advanced > View SSL Configurations**, and click **View SSL Configurations** to open the SSL computer Configurations window.
3. Click **New** to open the SSL Configuration wizard.
4. Specify the interface to which to apply the configuration on this computer:
 - To apply to all interfaces on this computer, select **All Interface(s)**.
 - To apply to specific interfaces, select **Specific Interface(s)**.
5. Select **Port(s)** or **Ports List** and select a list, then click **Next**.
6. On the IP Selection screen, select **All IPs** or provide a **Specific IP** on which to perform SSL inspection, then click **Next**.
7. On the Credentials screen, select how to provide the credentials:
 - **I will upload credentials now**
 - **The credentials are on the computer**

Note: The credential file must include the private key.

8. If you chose the option to upload credentials now, enter their type, location, and pass phrase (if required).

If the credentials are on the computer, provide Credential Details:

- If you are using PEM or PKCS#12 credential formats stored on the computer, identify the location of the credential file and the file's pass phrase (if required).

- If you are using Windows CryptoAPI credentials, choose the credentials from the list of credentials found on the computer.
9. Provide a name and description for this configuration.
 10. Review the summary and close the SSL Configuration Wizard. Read the summary of the configuration operation and click **Finish** to close the wizard.

Change port settings

Change the port settings for the computer to ensure that the agent is performing the appropriate Intrusion Prevention filtering on the SSL-enabled ports. The changes you make are applied to a specific application type, such as Web Server Common, on the agent computer. The changes do not affect the application type on other computers.

1. Go to **Intrusion Prevention Rules** in the computer's Details window to see the list of Intrusion Prevention rules being applied on this computer.
2. Sort the rules by **Application Type** and locate the "Web Server Common" application type. (You can perform these changes to similar application types as well.)
3. Right-click a rule in the application type and click **Application Type Properties**.
4. Override the inherited "HTTP" Port List so that you include the port you defined during the SSL Configuration setup as well as port 80. Enter the ports as comma-separated values. For example, if you use port 9090 in the SSL configuration, enter 9090, 80.
5. To improve performance, on the **Configuration** tab, deselect **Inherited and Monitor responses from Web Server**.
6. Click **OK** to close the dialog.

Use Intrusion Prevention when traffic is encrypted with Perfect Forward Secrecy (PFS)

[Perfect Forward Secrecy \(PFS\)](#) can be used to create a communication channel that cannot be decrypted if, at a later time, the server's private key is compromised. Since the intent of Perfect Forward Secrecy is to prevent decryption after the session is over, it also prevents the Intrusion Prevention module from seeing the traffic through SSL inspection.

Note:

Using Advanced TLS Traffic Inspection, the Intrusion Prevention module can analyze traffic encrypted with PFS ciphers without additional configuration.

To use PFS ciphers with SSL inspection instead, you can do the following:

1. Use Perfect Forward Secrecy for TLS traffic between the Internet and your load balancer or reverse proxy.
2. Terminate the Perfect Forward Secrecy session at your load balancer or reverse proxy.
3. Use a non-PFS cipher suite (see "[Supported cipher suites](#)" on the next page) for traffic between the load balancer (or reverse proxy) and the web server or application server, so that the Intrusion Prevention module on the server can decrypt the TLS sessions and inspect them.
4. Restrict traffic to the web server for application server ports that do not use Perfect Forward Secrecy.

Special considerations for Diffie-Hellman ciphers

Note:

This section only applies when using SSL Inspection instead of Advanced TLS Traffic Inspection.

Perfect Forward Secrecy relies on the Diffie-Hellman key exchange algorithm. On some web servers, Diffie-Hellman might be the default, which means that SSL inspection won't work properly. It is therefore important to check the server's configuration file and disable Diffie-Hellman ciphers for TLS traffic between the web server and load balancer (or reverse proxy). For example, to disable Diffie-Hellman on an Apache server:

1. Open the server's configuration file. The file name and location of web server configuration files vary by operating system (OS) and distribution. For example, the path could be:
 - **Default installation on RHEL4:** `/etc/httpd/conf.d/ssl.conf`
 - **Apache 2.2.2 on Red Hat Linux:** `/apache2/conf/extra/httpd-ssl.conf`
2. In the file, find the "SSLCipherSuite" variable.
3. Add `!DH:!EDH:!ADH:` to these fields, if this string does not already appear. (The "!" tells Apache to "not" use this cipher.)
4. For example, you might edit the Apache configuration file's cipher suite to look like this:

```
SSLCipherSuite
```

```
!DH:!EDH:!ADH:!EXPORT56:RC4+RSA:+HIGH:+MEDIUM:+LOW:+SSLv2:+EXP:+eNULL
```

For more information, see the Apache Documentation for SSLCipherSuite:
http://httpd.apache.org/docs/2.0/mod/mod_ssl.html#sslcipherSuite.

Supported cipher suites

Hex Value	OpenSSL Name	IANA Name	NSS Name	Advanced TLS Inspection	SSL inspection (legacy)
0x00,0x04	RC4-MD5	TLS_RSA_WITH_RC4_128_MD5	SSL_RSA_WITH_RC4_128_MD5	✓	✓
0x00,0x05	RC4-SHA	TLS_RSA_WITH_RC4_128_SHA	SSL_RSA_WITH_RC4_128_SHA	✓	✓
0x00,0x09	DES-CBC-SHA	TLS_RSA_WITH_DES_CBC_SHA	SSL_RSA_WITH_DES_CBC_SHA	✓	✓
0x00,0x0A	DES-CBC3-SHA	TLS_RSA_WITH_3DES_EDE_CBC_SHA	SSL_RSA_WITH_3DES_EDE_CBC_SHA	✓	✓
0x00,0x2F	AES128-SHA	TLS_RSA_WITH_AES_128_CBC_SHA	TLS_RSA_WITH_AES_128_CBC_SHA	✓	✓
0x00,0x33	DHE-RSA-AES128-SHA	TLS_DHE_RSA_WITH_AES_128_CBC_SHA	TLS_DHE_RSA_WITH_AES_128_CBC_SHA	✓	
0x00,0x35	AES256-SHA	TLS_RSA_WITH_AES_256_CBC_SHA	TLS_RSA_WITH_AES_256_CBC_SHA	✓	✓
0x00,0x39	DHE-RSA-AES256-SHA	TLS_DHE_RSA_WITH_	TLS_DHE_RSA_WITH_	✓	

Hex Value	OpenSSL Name	IANA Name	NSS Name	Advanced TLS Inspection	SSL inspection (legacy)
		AES_256_ CBC_SHA	AES_256_ CBC_SHA		
0x00,0x3C	AES128- SHA256	TLS_RSA_ WITH_AES_ 128_CBC_ SHA256	TLS_RSA_ WITH_AES_ 128_CBC_ SHA256	✓	✓
0x00,0x3D	AES256- SHA256	TLS_RSA_ WITH_AES_ 256_CBC_ SHA256	TLS_RSA_ WITH_AES_ 256_CBC_ SHA256	✓	✓
0x00,0x41	CAMELLIA128- SHA	TLS_RSA_ WITH_ CAMELLIA_ 128_CBC_SHA	TLS_RSA_ WITH_ CAMELLIA_ 128_CBC_SHA	✓	✓
0x00,0x67	DHE-RSA- AES128- SHA256	TLS_DHE_ RSA_WITH_ AES_128_ CBC_SHA256	TLS_DHE_ RSA_WITH_ AES_128_ CBC_SHA256	✓	
0x00,0x6b	DHE-RSA- AES256- SHA256	TLS_DHE_ RSA_WITH_ AES_256_ CBC_SHA256	TLS_DHE_ RSA_WITH_ AES_256_ CBC_SHA256	✓	
0x00,0x84	CAMELLIA256- SHA	TLS_RSA_ WITH_ CAMELLIA_ 256_CBC_SHA	TLS_RSA_ WITH_ CAMELLIA_ 256_CBC_SHA	✓	✓

Hex Value	OpenSSL Name	IANA Name	NSS Name	Advanced TLS Inspection	SSL inspection (legacy)
0x00,0x9c	AES128-GCM-SHA256	TLS_RSA_WITH_AES_128_GCM_SHA256	TLS_RSA_WITH_AES_128_GCM_SHA256	✓	✓
0x00,0x9d	AES256-GCM-SHA384	TLS_RSA_WITH_AES_256_GCM_SHA384	TLS_RSA_WITH_AES_256_GCM_SHA384	✓	✓
0x00,0x9e	DHE-RSA-AES128-GCM-SHA256	TLS_DHE_RSA_WITH_AES_128_GCM_SHA256	TLS_DHE_RSA_WITH_AES_128_GCM_SHA256	✓	
0x00,0x9f	DHE-RSA-AES256-GCM-SHA384	TLS_DHE_RSA_WITH_AES_256_GCM_SHA384	TLS_DHE_RSA_WITH_AES_256_GCM_SHA384	✓	
0x00,0xBA	CAMELLIA128-SHA256	TLS_RSA_WITH_CAMELLIA_128_CBC_SHA256	TLS_RSA_WITH_CAMELLIA_128_CBC_SHA256	✓	✓
0x00,0xC0	CAMELLIA256-SHA256	TLS_RSA_WITH_CAMELLIA_256_CBC_SHA256	TLS_RSA_WITH_CAMELLIA_256_CBC_SHA256	✓	✓
0xc0,0x09	ECDHE-	TLS_ECDHE_	TLS_ECDHE_	✓	

Hex Value	OpenSSL Name	IANA Name	NSS Name	Advanced TLS Inspection	SSL inspection (legacy)
	ECDSA- AES128-SHA	ECDSA_WITH_ AES_128_ CBC_SHA	ECDSA_WITH_ AES_128_ CBC_SHA		
0xc0,0x0A	ECDHE- ECDSA- AES256-SHA	TLS_ECDHE_ ECDSA_WITH_ AES_256_ CBC_SHA	TLS_ECDHE_ ECDSA_WITH_ AES_256_ CBC_SHA	✓	
0xc0,0x13	ECDHE-RSA- AES128-SHA	TLS_ECDHE_ RSA_WITH_ AES_128_ CBC_SHA	TLS_ECDHE_ RSA_WITH_ AES_128_ CBC_SHA	✓	
0xc0,0x14	ECDHE-RSA- AES256-SHA	TLS_ECDHE_ RSA_WITH_ AES_256_ CBC_SHA	TLS_ECDHE_ RSA_WITH_ AES_256_ CBC_SHA	✓	
0xc0,0x23	ECDHE- ECDSA- AES128- SHA256	TLS_ECDHE_ ECDSA_WITH_ AES_128_ CBC_SHA256	TLS_ECDHE_ ECDSA_WITH_ AES_128_ CBC_SHA256	✓	
0xc0,0x24	ECDHE- ECDSA- AES256- SHA384	TLS_ECDHE_ ECDSA_WITH_ AES_256_ CBC_SHA384	TLS_ECDHE_ ECDSA_WITH_ AES_256_ CBC_SHA384	✓	
0xc0,0x27	ECDHE-RSA- AES128- SHA256	TLS_ECDHE_ RSA_WITH_ AES_128_ CBC_SHA256	TLS_ECDHE_ RSA_WITH_ AES_128_ CBC_SHA256	✓	

Hex Value	OpenSSL Name	IANA Name	NSS Name	Advanced TLS Inspection	SSL inspection (legacy)
0xc0,0x28	ECDHE-RSA-AES256-SHA384	TLS_ECDHE_RSA_WITH_AES_256_CBC_SHA384	TLS_ECDHE_RSA_WITH_AES_256_CBC_SHA384	✓	
0xc0,0x2b	ECDHE-ECDSA-AES128-GCM-SHA256	TLS_ECDHE_ECDSA_WITH_AES_128_GCM_SHA256	TLS_ECDHE_ECDSA_WITH_AES_128_GCM_SHA256	✓	
0xc0,0x2c	ECDHE-ECDSA-AES256-GCM-SHA384	TLS_ECDHE_ECDSA_WITH_AES_256_GCM_SHA384	TLS_ECDHE_ECDSA_WITH_AES_256_GCM_SHA384	✓	
0xc0,0x2f	ECDHE-RSA-AES128-GCM-SHA256	TLS_ECDHE_RSA_WITH_AES_128_GCM_SHA256	TLS_ECDHE_RSA_WITH_AES_128_GCM_SHA256	✓	
0xc0,0x30	ECDHE-RSA-AES256-GCM-SHA384	TLS_ECDHE_RSA_WITH_AES_256_GCM_SHA384	TLS_ECDHE_RSA_WITH_AES_256_GCM_SHA384	✓	
0xc0,0x9c	AES128-CCM	TLS_RSA_WITH_AES_128_CCM	TLS_RSA_WITH_AES_128_CCM	✓	✓
0xc0,0x9d	AES256-CCM	TLS_RSA_WITH_AES_256_CCM	TLS_RSA_WITH_AES_256_CCM	✓	✓

Hex Value	OpenSSL Name	IANA Name	NSS Name	Advanced TLS Inspection	SSL inspection (legacy)
0xC0,0xA0	AES128-CCM8	TLS_RSA_ WITH_AES_ 128_CCM_8	TLS_RSA_ WITH_AES_ 128_CCM_8	✓	✓
0xC0,0xA1	AES256-CCM8	TLS_RSA_ WITH_AES_ 256_CCM_8	TLS_RSA_ WITH_AES_ 256_CCM_8	✓	✓
0xcc,0xa8	ECDHE-RSA- CHACHA20- POLY1305	TLS_ECDHE_ RSA_WITH_ CHACHA20_ POLY1305_ SHA256	TLS_ECDHE_ RSA_WITH_ CHACHA20_ POLY1305_ SHA256	✓	
0xcc,0xa9	ECDHE- ECDSA- CHACHA20- POLY1305	TLS_ECDHE_ ECDSA_WITH_ CHACHA20_ POLY1305_ SHA256	TLS_ECDHE_ ECDSA_WITH_ CHACHA20_ POLY1305_ SHA256	✓	
0xcc,0xaa	DHE-RSA- CHACHA20- POLY1305	TLS_DHE_ RSA_WITH_ CHACHA20_ POLY1305_ SHA256	TLS_DHE_ RSA_WITH_ CHACHA20_ POLY1305_ SHA256	✓	

Supported protocols

The following protocols are supported:

- TLS 1.0
- TLS 1.1
- TLS 1.2

SSL 3.0 inspection is **not** supported and will be blocked by default.

TLS inspection support

- [Deep Security Agent 20 TLS inspection support](#)

Manage TLS inspection support package updates

This feature always updates the TLS inspection support package for supported platforms, but allows you to disable other unnecessary updates.

This feature requires:

- Deep Security Manager 20.0.665+
- Deep Security Agent 20.0.0.5512+ on supported platforms. It is not supported on AIX or Solaris.

For a list of supported platforms with **Advanced TLS traffic inspection** feature, see the ["Supported features by platform" on page 360](#)

Disable TLS inspection support package updates on a single agent

1. In Deep Security Manager, go to the **Computers** page.
2. Double-click the computer where you want to disable updates (or select the computer and then the **Details** button).
3. Select **Settings**. Change **Automatically update TLS inspection package for Advanced TLS Traffic Inspection** to **No**.
4. Save your changes.

Disable TLS inspection support package updates by policy

This method disables TLS inspection support package updates for all computers protected by the same policy.

1. In Deep Security Manager, go to the **Policies** page.
2. Double-click the policy where you want to disable updates (or select the policy and then the **Details** button). You can also create a new policy instead of updating an existing policy.
3. Select **Settings**. Change **Automatically update TLS inspection package for Advanced TLS Traffic Inspection** to **No**.
4. Save your changes.

Configure anti-evasion settings

Anti-evasion settings control the network engine handling of abnormal packets that may be attempting to evade analysis. Anti evasion settings are configured in a policy or an individual computer. The Security Posture setting controls how rigorous intrusion prevention analyzes packets, and can be set to one of the following values:

- **Normal:** Prevents the evasion of intrusion prevention rules without false positives. This is the default value.
- **Strict:** Performs more stringent checking than Normal mode but can produce some false-positive results. Strict mode is useful for penetration testing but should not be enabled under normal circumstances.
- **Custom:** If you select **Custom**, additional settings are available that enable you to specify how Deep Security will handle issues with packets. For these settings (with the exception of **TCP Timestamp PAWS Window**), the options are **Allow** (Deep Security sends the packet through to the system), **Log Only** (same behavior as Allow, but an event is logged), **Deny** (Deep Security drops the packet and logs an event), or **Deny Silent** (same behavior as Deny, but no event is logged):

Note: If you changed the posture to "Custom" in Deep Security 10.1 or earlier, all default values for the anti-evasion settings were set to "Deny". This led to a dramatic increase in block events. The default custom values have changed in Deep Security 10.2, as indicated in the table below.

Setting	Description	Normal value	Strict value	Default custom value (pre-10.2)	Default custom value (10.2 or later)
Invalid TCP Timestamps	Action to take when a TCP timestamp is too old	Ignore and Log (same function as Log Only)	Deny	Deny	Ignore and Log (same function as Log Only)
TCP Timestamp PAWS	Packets can have timestamps. When a	1 for Linux agents,	1 for Linux agents,	0	1 for Linux agents,

Setting	Description	Normal value	Strict value	Default custom value (pre-10.2)	Default custom value (10.2 or later)
Window	timestamp has an earlier timestamp than the one that came before it, it can be suspicious. The tolerance for the difference in timestamps depends on the operating system. For Windows systems, select 0 (the system will only accept packets with a timestamp that is equal to or newer than the previous packet). For Linux systems, select 1 (the system will accept packets with a timestamp that is a maximum of one second earlier than the previous packet).	otherwise 0	otherwise 0		otherwise 0
Timestamp PAWS Zero Allowed	Action to take when a TCP timestamp is zero	Deny for Linux agents or NDIS5, otherwise Allow	Deny for Linux agents or NDIS5, otherwise Allow	Deny	Deny for Linux agents or NDIS5, otherwise Allow
Fragmented Packets	Action to take when a packet is fragmented	Allow	Allow	Deny	Allow
TCP Zero Flags	Action to take when a packet has zero flags set	Deny	Deny	Deny	Deny
TCP Congestion Flags	Action to take when a packet has congestion flags set	Allow	Allow	Deny	Allow
TCP Urgent Flags	Action to take when a packet has urgent flags set	Allow	Deny	Deny	Allow
TCP Syn Fin Flags	Action to take when a packet has both SYN and FIN flags	Deny	Deny	Deny	Deny

Setting	Description	Normal value	Strict value	Default custom value (pre-10.2)	Default custom value (10.2 or later)
	set				
TCP Syn Rst Flags	Action to take when a packet has both SYN and RST flags set	Deny	Deny	Deny	Deny
TCP Rst Fin Flags	Action to take when a packet has both RST and FIN flags set	Deny	Deny	Deny	Deny
TCP Syn with Data	Action to take when a packet has a SYN flag set and also contains data	Deny	Deny	Deny	Deny
TCP Split Handshake	Action to take when a SYN is received instead of SYN-ACK, as a reply to a SYN.	Deny	Deny	Deny	Deny
RST Packet Out of Connection	Action to take for a RST packet without a known connection	Allow	Deny	Deny	Allow
FIN Packet Out of Connection	Action to take for a FIN packet without a known connection	Allow	Deny	Deny	Allow
OUT Packet Out of Connection	Action to take for an outgoing packet without a known connection	Allow	Deny	Deny	Allow
Evasive Retransmit	Action to take for a packet with duplicated or overlapping data	Allow	Deny	Deny	Allow
TCP Checksum	Action to take for a packet with an invalid checksum	Allow	Deny	Deny	Allow

Performance tips for intrusion prevention

To improve system resources utilization on Deep Security Agent, optimize certain performance-related settings.

For an overview of the intrusion prevention module, see ["About Intrusion Prevention" on page 878](#).

System resource	Settings that impact performance
CPU usage	<ul style="list-style-type: none"> • Log an event when a packet is dropped or blocked. Logging packet modifications may result in a lot of log entries. (See "Configure event logging for rules" on page 893) • Include packet data in the event log only during troubleshooting. (See "Configure event logging for rules" on page 893) • Assign only intrusion prevention rules that apply to the computer's OS and applications. See "Manage and run recommendation scans" on page 705 for information about using recommendation scans to discover applicable vulnerabilities and rules. • Don't assign more than 300 rules.
Network usage or throughput	<ul style="list-style-type: none"> • Log an event when a packet is dropped or blocked. Logging packet modifications may result in a lot of log entries. (See "Configure event logging for rules" on page 893) • Include packet data in the event log only during troubleshooting. (See "Configure event logging for rules" on page 893) • Do not monitor HTTP responses from the web server, especially if the policy has many signatures applied: <ol style="list-style-type: none"> a. Click Policies > Intrusion Prevention Rules. b. Right-click a rule in the Web Server Common application type and click Application Type Properties. c. On the Configuration tab, deselect Inherited and Monitor responses from Web Server.
Disk usage	<ul style="list-style-type: none"> • Include packet data in the event log only during troubleshooting. (See

System resource	Settings that impact performance
	"Configure event logging for rules" on page 893)

Maximum size for configuration packages

When an agent is assigned a large number of intrusion prevention rules, the size of the configuration package can exceed the maximum allowed size. When the allowed size is exceeded, the status of the agent changes to "Agent configuration package too large" and the event message "Configuration package too large" appears.

Note: There is a configuration limit of 20 MB in Windows 32-bit platform because it has smaller kernel memory available. For other platforms, the limit is 32 MB.

For performance reasons, you should have less than 350 intrusion prevention rules assigned to a computer. To minimize the number of required rules, ensure all available patches are applied to the computer operation system and any third-party software that is installed.

1. Apply available patches to the computer operating system.
2. Apply available patches to any third-party software that is installed.
3. Apply only the intrusion prevention rules that a recommendation scan recommends. Remove any rules from the computer or the assigned policy that are recommended for unassignment. (See ["Manage and run recommendation scans" on page 705.](#))
4. If you are managing intrusion prevention at the policy level and the configuration package is still too large, configure intrusion prevention in one of the following ways:
 - Make the policy more granular, so that all servers in that policy have the same operating system and applications.
 - Manage intrusion prevention at the server level so that rules are added and removed automatically for the computer.

Use the following procedure to manage intrusion prevention at the server level.

1. Open the editor for the policy that is assigned to the computer.
2. Click **Intrusion Prevention > General**.
3. In the **Recommendations** section, set **Automatically implement Intrusion Prevention Recommendations (when possible)** to **Yes**.
4. Remove any intrusion prevention rules from the policy.
5. Run a recommendation scan on the computer.

Configure Firewall

About Firewall

The firewall module provides bidirectional stateful inspection of incoming and outgoing traffic. Firewall rules define what actions to take on individual packets in that traffic. Packets can be filtered by IP and MAC address, port and packet flag across all IP-based protocols and frame types. The firewall module can also help prevent denial of service attacks and detect and prevent reconnaissance scans.

To enable and configure the firewall, see ["Set up the Deep Security firewall" on the next page](#).

Firewall rules

Firewall rules can process traffic using one of the following actions, listed in order of precedence:

- Bypass
- Log Only
- Force Allow
- Deny
- Allow

Rules also have a priority level between 4 (highest priority) to 0 (lowest priority). Within a specific priority level rules are processed in order based on the precedence of the action type of the rule as listed above. This means that unlike what you may have experienced when configuring other firewalls, the Deep Security firewall processes rules independently of their assignment order.

For more information on how rule priorities and actions determine processing order, see ["Firewall rule actions and priorities" on page 946](#).

For more detailed information on how to create firewall rules, see ["Create a firewall rule" on page 939](#).

Note: When creating your rules, make sure to test them using the Tap and Inline modes of the firewall module before deploying them. For information on how to do so, see the "Test firewall rules before deploying them" section of ["Set up the Deep Security firewall" on the next page](#).

Set up the Deep Security firewall

The Deep Security Firewall is a highly flexible Firewall that you can configure to be restrictive or permissive. Like the intrusion prevention and web reputation modules, the Firewall module can also be run in two modes: inline or tap. It is recommended that you test your Firewall rules in tap mode and then switch to inline mode when everything is working correctly.

The configuration and administration of your Firewall must be performed carefully and there is no one set of rules that fits all environments. Make sure you understand the Firewall rule actions and rule priorities before creating your rules and proceed with extra caution when creating Allow rules because they implicitly deny everything else not defined.

In this article:

- ["Test Firewall rules before deploying them" below](#)
- ["Enable 'fail open' behavior" on page 929](#)
- ["Turn on Firewall " on page 930](#)
- ["Default Firewall rules" on page 931](#)
- ["Restrictive or permissive Firewall design" on page 932](#)
- ["Firewall rule actions" on page 933](#)
- ["Firewall rule priorities" on page 934](#)
- ["Recommended Firewall policy rules" on page 935](#)
- ["Test Firewall rules" on page 935](#)
- ["Reconnaissance scans" on page 936](#)
- ["Stateful inspection" on page 937](#)
- ["Example" on page 938](#)
- ["Important things to remember" on page 939](#)

Test Firewall rules before deploying them

The Firewall module (as well as the intrusion prevention and web reputation modules) includes a Deep Security network engine that decides whether to block or allow packets. For the Firewall and intrusion prevention modules, the network engine performs a packet sanity check and also makes sure each packet passes the Firewall and intrusion prevention rules. The network engine operates in one of two modes:

- **Tap mode:** Packet streams are not modified. The traffic is still processed by the Firewall and/or intrusion prevention modules, if they are enabled. However any issues detected do not result in packet or connection drops. When in Tap mode, Deep Security offers no protection beyond providing a record of events.
- **Inline mode:** Packet streams pass directly through the Deep Security network engine. All rules are applied to the network traffic before they proceed up the protocol stack.

It's important to test your Firewall rules in either Tap mode or Inline mode with the action for the rules set to Log Only before deploying them. This allows you to preview the effect of the rules on traffic, without any action being taken. If rules aren't properly tested before deployment, all traffic could become blocked and your computer could become inaccessible.

Test in Tap mode

Tap mode allows you to test your Firewall rules, without disturbing the flow of traffic.

1. Go to **Computers** or **Policies** in the Deep Security Manager.
2. Right-click a computer (or policy) and select **Details** to open the **Computer or Policy editor**¹.
3. Go to **Settings > Advanced > Network Engine Mode**.
4. Select **Tap** from the list and click **Save**.
5. Create your rules and click **OK**. To check your rules, go to **Events & Reports > Events > Firewall Events**.

Note: It is not necessary to set the action of the rule to Log Only in Tap mode.

Once you are satisfied with your Firewall rules, go back to the **Computer or Policy editor**², select **Inline** from the drop-down list, and click **Save**.

Test in Inline mode

In most situations, Tap mode is a good way to test your Firewall rules without disturbing traffic. However, you can also test your rules in Inline mode, if the action of the rule is set to Log Only.

¹You can change these settings for a policy or for a specific computer. To change the settings for a policy, go to the Policies page and double-click the policy that you want to edit (or select the policy and click Details). To change the settings for a computer, go to the Computers page and double-click the computer that you want to edit (or select the computer and click Details).

²You can change these settings for a policy or for a specific computer. To change the settings for a policy, go to the Policies page and double-click the policy that you want to edit (or select the policy and click Details). To change the settings for a computer, go to the Computers page and double-click the computer that you want to edit (or select the computer and click Details).

This way, the real world process of analyzing the traffic takes place without having to perform any action, such as blocking or denying packets.

1. Go to **Computers** or **Policies** in the Deep Security Manager.
2. Right-click a computer (or policy) and select **Details** to open the **Computer or Policy editor**¹.
3. Go to **Settings > Advanced > Network Engine Mode**.
4. Select **Inline** from the drop down menu and click **Save**.
5. While you're creating your rule, ensure the action is set to **Log Only**.
6. To check your rules, go to **Events & Reports > Events > Firewall Events**.

Once you are satisfied with your Firewall rules, change the action from Log Only to your desired action and click **OK**.

Enable 'fail open' behavior

In some cases, the network engine blocks packets before the Firewall rules (or intrusion prevention rules) can be applied. By default, the network engine blocks packets if the:

- agent or virtual appliance has a system problem, such as if it's out of memory
- packet sanity check fails

This 'fail closed' behavior offers a high level of security: it ensures that cyber attacks cannot penetrate your network when an agent or virtual appliance is not functioning properly, and safeguards against potentially malicious packets. The disadvantage to 'fail closed' is that your services and applications might become unavailable because of problems on the agent or virtual appliance. You might also experience performance issues if a large number of packets are being dropped unnecessarily as a result of the packet sanity check (too many false-positives).

If you have concerns about service availability, consider changing the default behavior to allow packets through (or 'fail open') for system and packet check failures, as explained below.

1. Go to **Computers** or **Policies** in the Deep Security Manager.
2. Right-click a computer (or policy) and select **Details** to open the **Computer or Policy editor**².

¹You can change these settings for a policy or for a specific computer. To change the settings for a policy, go to the Policies page and double-click the policy that you want to edit (or select the policy and click Details). To change the settings for a computer, go to the Computers page and double-click the computer that you want to edit (or select the computer and click Details).

²You can change these settings for a policy or for a specific computer. To change the settings for a policy, go to the Policies page and double-click the policy that you want to edit (or select the policy and click Details). To change the settings for a computer, go to the Computers page and double-click the computer that you want to edit (or select the computer and click Details).

3. Click **Settings** on the left.
4. Click the **Advanced** tab.
5. Under **Network Engine Settings**, set the **Failure Response** settings as follows:
6. Set **Network Engine System Failure** to **Fail open** to allow packets through if the Deep Security network engine experiences problems, such as out-of-memory failures, allocated memory failures, and network engine deep packet inspection (DPI) decoding failures. Consider using fail open here if your agent or virtual appliance frequently encounters network exceptions because of heavy loads or a lack of resources. With fail open, the network engine allows the packet through, does not perform Intrusion Prevention rules checking, and logs an event. Your services and applications remain available despite the problems on the agent or virtual appliance.
7. Set **Network Packet Sanity Check Failure** to **Fail open** to allow packets through that fail the network engine's packet sanity checks. Examples of packet sanity checks: Firewall sanity checks, network layer 2, 3, or 4 attribute checks, and TCP state checks. Consider using fail open here if you want to perform Intrusion Prevention rules checking only on 'good' packets that pass the sanity check. With fail open, the network engine allows the failed packet through, does not perform Intrusion Prevention rules checking on it, and logs an event.
8. Click **Save**.

You have now enabled fail open behavior for system or packet check failures.

Turn on Firewall

To enable Firewall functionality on a computer:

1. In the **Computer or Policy editor**¹, go to **Firewall > General**.
2. With Deep Security Agent 11.1 and earlier, the Firewall module inspects traffic that passes through the host computer's network interface to containers. With Deep Security Agent 11.2 or later, it can also inspect traffic between containers. When the **Scan container network traffic** setting is set to **Yes**, Deep Security scans the traffic that goes through both containers and hosts. When it is set to **No**, Deep Security scans only the traffic that goes through the host network interface.
3. Select **On** and then click **Save**.

¹You can change these settings for a policy or for a specific computer. To change the settings for a policy, go to the Policies page and double-click the policy that you want to edit (or select the policy and click Details). To change the settings for a computer, go to the Computers page and double-click the computer that you want to edit (or select the computer and click Details).

Note: When you enable the Deep Security Firewall with at least one firewall rule, the Agent disables the Windows Firewall automatically to prevent conflicts.

Default Firewall rules

No outbound rules are assigned to the policies that come with Deep Security by default but several recommended inbound rules are. You can view the default inbound rules assigned to each policy by going to the **Firewall** tab in the relevant operating system policy. The example below shows the default assigned Firewall rules for the Windows 10 Desktop policy. You can configure these Firewall rules to meet the needs of your environment, but we have provided several default rules for you to get you started.

Tip: To minimize the impact on system performance, try not to assign more than 300 Firewall rules. It is also good practice to document all Firewall rule changes in the "Description" field of the Firewall rule. Make a note of when and why rules were created or deleted for easier Firewall maintenance.

The screenshot displays the 'Firewall' configuration page in the Trend Micro Deep Security console. The left sidebar shows various security modules, with 'Firewall' selected. The main content area is divided into several sections:

- General:** Configuration is set to 'Inherited (On)' and the state is 'On, 16 rules'.
- Firewall Stateful Configurations:** Lists configurations for 'Global (All Interfaces)', 'eth1 (N/A) - 00:50:56:91:84:03', 'virbr0 - 52:54:00:3D:29:7D', and 'eth2 - 00:50:56:91:0E:5A'. Each has a dropdown menu set to 'Inherited (Enable Stateful Inspection)' and an 'Edit' button.
- Port Scan:** Shows 'Last Port Scan: N/A', 'Scanned Ports: N/A', and 'Open Ports: N/A'. There are buttons for 'Scan For Open Ports' and 'Cancel Port Scan'.
- Container Protection:** 'Scan container network traffic' is set to 'Inherited (No)'.
- Assigned Firewall Rules:** A table with columns: NAME, ACTION TYP..., PRIORL..., DIRECTI..., FRAME T..., PROTO..., SOURCE IP, SOURCE M..., SOURCE P..., DESTINATIO..., and DE. The table contains three visible rules:

NAME	ACTION TYP...	PRIORL...	DIRECTI...	FRAME T...	PROTO...	SOURCE IP	SOURCE M...	SOURCE P...	DESTINATIO...	DE
Allow solicited ICMP replies	Allow	0 - Lowest	Incoming	IP	ICMP	Any	Any	N/A	Any	Any
Allow solicited TCP/UDP replies	Allow	0 - Lowest	Incoming	IP	TCP+UDP	Any	Any	Any	Any	Any
ARP	Allow	0 - Lowest	Incoming	ARP	N/A	N/A	Any	N/A	N/A	Any

At the bottom right, there are 'Save' and 'Close' buttons.

Default Bypass rule for Deep Security Manager Traffic

The Deep Security Manager automatically implements a **Priority 4 Bypass Rule** that opens the listening port number of the agent for heartbeats on computers running Deep Security Agent. A priority of 4 ensures that this rule is applied before any Deny rule, and Bypass guarantees that the traffic is never impaired. The Bypass rule is not explicitly shown in the Firewall rule list because the rule is created internally.

This rule, however, accepts traffic from any IP address and any MAC address. To harden the Deep Security Agent's listening ports, you can create an alternative, more restrictive, Bypass rule for this port. The agent will override the default Deep Security Manager traffic rule with the new custom rule if it has these settings:

- **Priority:** 4 - Highest
- **Packet direction:** Incoming
- **Frame type:** IP
- **Protocol:** TCP
- **Packet Destination Port:** [Agent's listening port for heartbeats](#)

The custom rule must use the above parameters to replace the default rule. Ideally, the IP address or MAC address of the actual Deep Security Manager should be used as the packet source for the rule.

Restrictive or permissive Firewall design

Typically, Firewall policies are based on one of two design strategies. Either they permit any service unless it is expressly denied or they deny all services unless expressly allowed. It is best practice to decide what type of Firewall you would like to implement. This helps reduce administrative overhead in terms of creating and maintaining the rules.

Restrictive Firewall

A restrictive Firewall is the recommended best practice from a security perspective. All traffic is stopped by default and only traffic that has been explicitly allowed is permitted. If the primary goal of your planned Firewall is to block unauthorized access, the emphasis needs to be on restricting rather than enabling connectivity. A restrictive Firewall is easier to maintain and more secured. Allow rules are used only to permit certain traffic across the Firewall and deny everything else.

Note: As soon as you assign a single outgoing Allow rule, the outgoing Firewall will operate in restrictive mode. This is also true for the inbound Firewall: as soon as you assign a single incoming Allow rule, the inbound Firewall will operate in restrictive mode.

Permissive Firewall

A permissive Firewall permits all traffic by default and only blocks traffic known bad port/protocol based on what deny firewall rules configured. A permissive Firewall is easy to implement but it provides minimal security and requires complex rules. Deny rules are used to explicitly block traffic.

Firewall rule actions

You can configure the Firewall to take the following actions:

Warning: If you assign only incoming rules, all outgoing traffic will be allowed. If you assign a single outgoing Allow rule, the outgoing Firewall will operate in restrictive mode. There is one exception to this: ICMPv6 traffic is always permitted unless it is specifically blocked by a Deny rule.

Allow	<p>Explicitly allows traffic that matches the rule to pass and then implicitly denies everything else.</p> <p>Note: You should use an Allow action with caution because it implicitly denies everything else not defined. Be careful when creating Allow rules without defining the related rules correctly because doing so can cause all traffic to be blocked except for the traffic that the Allow rule is created for. Traffic that is not explicitly allowed by an Allow rule is dropped and gets recorded as a 'Out of "allowed" Policy' Firewall event.</p>
Bypass	<p>Allows traffic to bypass both Firewall and intrusion prevention analysis. Bypass rules should always be created in pairs (for both incoming and outgoing traffic). A Bypass rule can be based on IP, port, traffic direction, and protocol.</p> <p>The Bypass rule is designed for media-intensive protocols or traffic originating from trusted sources.</p>
Deny	<p>Explicitly blocks traffic that matches the rule.</p>

Force Allow	<p>If a packet matches a force allow rule, it is passed but still filtered by intrusion prevention. No events are logged.</p> <p>This type of Firewall rule action must be used for UDP and ICMP traffic.</p>
Log only	<p>Traffic will only be logged. No other action will be taken.</p>

For more information on how to create a Firewall rule, see ["Create a firewall rule" on page 939](#).

Firewall rule priorities

Rule priority determines the order in which filters are applied. This means that high priority rules get applied before low priority rules. When actions share the same priority, the orders of precedence for rules are: Bypass, Force Allow, and then Deny. However, a Deny action with a higher priority will take precedence over a Bypass action with a lower priority. For more information on how rule priorities and actions determine processing order, see ["Firewall rule actions and priorities" on page 946](#).

To simplify the administration of Firewall rules, consider reserving certain priority levels for specific actions. For example, apply a default of priority 3 to rules that use Bypass, priority 2 for Force Allow rules, and priority 1 for Deny rules. This reduces the potential for rule conflicts.

Allow rules

Allow rules can only have a priority of 0. This is to ensure it is processed after all Force Allow and Deny rules at higher priorities. Keep this in mind when using Allow rules to implicitly deny traffic (any traffic not matching the Allow rules are denied). This means that when a Deny rule is assigned, it will take precedence over all of the existing assigned Allow rules.

Force Allow rules

Force Allow rules are recommended for traffic that must always be allowed, such as Address Resolution Protocol (ARP). The Force Allow action only acts as a trump card to a deny rule at the same or higher priority. For example, if you have a Deny rule at priority 3 that prevents access to an allowed port number from the 10.0.0.0/8 subnet, and you want to allow host 10.102.12.56 to access that, you must create a Force Allow rule at priority 3 or 4 to trump the Deny rule at priority 3. Once a packet triggers this rule, it is immediately allowed and the lower priority rules will not process it anymore.

Bypass rules

The Bypass rule is a special type of rule that allows a packet to bypass both the Firewall and Deep Packet Inspection (DPI) engines. This rule must be priority 4 and created in pairs, one rule for each traffic direction.

Recommended Firewall policy rules

We recommend that you make the following rules mandatory for all of your Firewall policies:

- **ARP:** Allows incoming ARP requests so that the computer can reply to queries for its MAC address. If you do not assign this rule, no devices on the network can query the host for its MAC address and it will be inaccessible from the network.
- **Allow solicited TCP/UDP replies:** Allows the computer to receive replies to its own TCP connections and UDP messages. This works in conjunction with TCP and UDP stateful Firewall configuration.
- **Allow solicited ICMP replies:** Allows the computer to receive replies to its own ICMP messages. This works in conjunction with ICMP stateful Firewall configuration.
- **DNS Server:** Allows DNS servers to receive inbound DNS queries.
- **Remote Access RDP:** Allows the computer to accept Remote Desktop connections.
- **Remote Access SSH:** Allows the computer to accept SSH connections.

Test Firewall rules

Before continuing with further Firewall configuration steps, test the recommended Firewall rules to ensure they're working correctly.

Test the remote access SSH rule:

1. Try to establish a SSH connection to the computer. If the Firewall is enabled and the Remote Access SSH rule is not enabled, the connection will be denied. Go to **Events & Reports > Firewall Events** to view the denied event.
2. Go to the **Computer or Policy editor**¹ > **Firewall**. Under **Assigned Firewall Rules**, click **Assign/Unassign**.
3. Search for Remote Access SSH and enable the rule. Click **OK** and **Save**.
4. Try to establish a SSH connection to the computer. The connection should be allowed.

¹You can change these settings for a policy or for a specific computer. To change the settings for a policy, go to the Policies page and double-click the policy that you want to edit (or select the policy and click Details). To change the settings for a computer, go to the Computers page and double-click the computer that you want to edit (or select the computer and click Details).

Test the remote access RDP rule:

1. Try to establish a RDP connection to the computer. If the Firewall is enabled and the Remote Access RDP rule is not enabled, the connection will be denied. Go to **Events & Reports > Firewall** events to view the denied event.
2. Go to the **Computer or Policy editor**¹ > **Firewall**. Under **Assigned Firewall Rules**, click **Assign/Unassign**.
3. Search for Remote Access RDP and enable the rule. Click **OK** and **Save**.
4. Try to establish a RDP connection to the computer. The connection should be allowed.

Reconnaissance scans

You can configure the Firewall to detect possible reconnaissance scans and help prevent attacks by blocking traffic from the source IPs for a period of time. Once an attack has been detected, you can instruct agents and appliances to block traffic from the source IPs for a period of time. Use the Block Traffic lists on the on the **Policy or Computer Editor > Firewall > Reconnaissance** tab to set the number of minutes.

- **Computer OS Fingerprint Probe:** The agent or appliance detects an attempt to discover the computer's OS.
- **Network or Port Scan:** The agent or appliance reports a network or port scan if it detects that a remote IP is visiting an abnormal ratio of IPs to ports. Normally, an agent or appliance computer will only see traffic destined for itself, so a port scan is the most common type of probe that will be detected. The statistical analysis method used in computer or port scan detection is derived from the "TAPS" algorithm proposed in the paper "Connectionless Port Scan Detection on the Backbone" presented at IPCCC in 2006.
- **TCP Null Scan:** The agent or appliance detects packages with no flags set.
- **TCP SYNFIN Scan:** The agent or appliance detects packets with only the SYN and FIN flags set.
- **TCP Xmas Scan:** The agent or appliance detects packets with only the FIN, URG, and PSH flags set or a value of 0xFF (every possible flag set).

For each type of attack, the agent or appliance can be instructed to send the information to the Deep Security Manager where an alert will be triggered by selecting the option **Notify DSM**

¹You can change these settings for a policy or for a specific computer. To change the settings for a policy, go to the Policies page and double-click the policy that you want to edit (or select the policy and click Details). To change the settings for a computer, go to the Computers page and double-click the computer that you want to edit (or select the computer and click Details).

Immediately. For this option to work, the agents and appliances must be configured for agent or appliance-initiated or bidirectional communication in **Policy / Computer Editor > Settings > General > Communication Direction**. If enabled, the agent or appliance will initiate a heartbeat to the Deep Security Manager immediately upon detecting the attack or probe.

Note: If you want to enable reconnaissance protection, you must also enable the Firewall and stateful inspection on the **Policy or Computer Editor > Firewall > General** tab. You should also go to the **Policy or Computer Editor > Firewall > Advanced** tab and enable the **Generate Firewall Events** for packets that are 'Out of Allowed Policy' setting. This will generate Firewall events that are required for reconnaissance.

Note: The reconnaissance scans detection requires there to be at least one active Firewall rule assigned to the policy of the agent.

For information on how to handle reconnaissance warnings, see "[Warning: Reconnaissance Detected](#)" on page 1402.

Stateful inspection

Deep Security Firewall stateful configuration mechanism should be enabled when the Firewall is on. This mechanism analyzes each packet in the context of traffic history, correctness of TCP and IP header values, and TCP connection state transitions. In the case of stateless protocols like UDP and ICMP, a pseudo-stateful mechanism is implemented based on historical traffic analysis.

Packets are handled by the stateful mechanism as follows:

1. A packet is passed to the stateful routine if it has been allowed through by the static Firewall rule conditions.
2. The packet is examined to determine whether it belongs to an existing connection.
3. The TCP header is examined for correctness (for example, sequence numbers, flag combinations, and so on).

The Deep Security Firewall stateful configuration enables protection against attacks such as denial of service, provided that a default configuration with stateful TCP, ICMP, or UDP protocol is enabled and only solicited replies are allowed. If the UDP stateful option is enabled, Force Allow must be used when running UDP servers (for example, DHCP). If there is no DNS or WINS server configured for the Deep Security Agents, a Force Allow Incoming UDP Ports 137 rule might be required for NetBIOS.

Stateful logging should be disabled unless required for ICMP or UDP protocols.

Example

This is an example of how a simple Firewall policy can be created for a web server:

1. Enable stateful inspection for TCP, UDP, and ICMP using a global Firewall stateful configuration with these options enabled.
2. Add a Firewall rule to allow TCP and UDP replies to requests originated on the workstation. To do this create an incoming Allow rule with the protocol set to **TCP + UDP** and select **Not** and **Syn** under **Specific Flags**. At this point the policy only allows TCP and UDP packets that are replies to requests initiated by a user on the workstation. For example, in conjunction with the stateful analysis options enabled in step 1, this rule allows a user on this computer to perform DNS lookups (via UDP) and to browse the Web via HTTP (TCP).
3. Add a Firewall rule to allow ICMP replies to requests originated on the workstation. To do this, create an incoming Allow rule with the protocol set to **ICMP** and select the **Any Flags** check box. This means that a user on this computer can ping other workstations and receive a reply but other users will not be able to ping this computer.
4. Add a Firewall rule to allow incoming TCP traffic to port 80 and 443 with the **Syn** check box checked in the **Specific Flags** section. This means that external users can access a Web server on this computer.

At this point we have a basic Firewall policy that allows solicited TCP, UDP and ICMP replies and external access to the Web server on this computer all other incoming traffic is denied.

For an example of how Deny and Force Allow rule actions can be used to further refine this policy consider how we may want to restrict traffic from other computers in the network. For example, we may want to allow access to the Web server on this computer to internal users but deny access from any computers that are in the DMZ. This can be done by adding a Deny rule to prohibit access from servers in the DMZ IP range.

5. Add a Deny rule for incoming TCP traffic with source IP 10.0.0.0/24 which is the IP range assigned to computers in the DMZ. This rule denies any traffic from computers in the DMZ to this computer.

We may, however, want to refine this policy further to allow incoming traffic from the mail server which resides in the DMZ.

6. Use a Force Allow for incoming TCP traffic from source IP 10.0.0.100. This Force Allow overrides the Deny rule we created in the previous step to permit traffic from this one computer in the DMZ.

Important things to remember

- All traffic is first checked against Firewall rules before being analyzed by the stateful inspection engine. If the traffic clears the Firewall rules, the traffic is then analyzed by the stateful inspection engine (provided stateful inspection is enabled in the Firewall Stateful Configuration).
- Allow rules are prohibitive. Anything not specified in the Allow rules is automatically dropped. This includes traffic of other frame types so you need to remember to include rules to allow other types of required traffic. For example, don't forget to include a rule to allow ARP traffic if static ARP tables are not in use.
- If UDP stateful inspection is enabled a Force Allow rule must be used to allow unsolicited UDP traffic. For example, if UDP stateful inspection is enabled on a DNS server then a Force Allow for port 53 is required to allow the server to accept incoming DNS requests.
- If ICMP stateful inspection is enabled a Force Allow rule must be used to allow unsolicited ICMP traffic. For example, if you wish to allow outside ping requests a Force Allow rule for ICMP type 3 (Echo Request) is required.
- A Force Allow acts as a trump card only within the same priority context.
- If you do not have a DNS or WINS server configured (which is common in test environments) a "Force Allow incoming UDP port 137" rule may be required for NetBIOS (Windows shares).

Note: When troubleshooting a new Firewall policy the first thing you should do is check the Firewall rule logs on the **agent or appliance**¹. The Firewall rule logs contain all the information you need to determine what traffic is being denied so that you can further refine your policy as required.

Create a firewall rule

Firewall rules examine the control information in individual packets, and either block or allow them according to the criteria that you define. Firewall rules can be assigned to a policy or directly to a computer.

¹The Deep Security Agent and Deep Security Virtual Appliance are the components that enforce the Deep Security policies that you have defined. Agents are deployed directly on a computer. Appliances are used in VMware vSphere environments to provide agentless protection. They are not available with Deep Security as a Service.

Note: This article specifically covers how to create a firewall rule. For information on how to configure the firewall module, see ["Set up the Deep Security firewall" on page 927](#).

To create a new firewall rule, you need to:

1. ["Add a new rule" below](#).
2. ["Select the behavior and protocol of the rule" below](#).
3. ["Select a Packet Source and Packet Destination" on page 943](#).

When you're done with your firewall rule, you can also learn how to:

- ["Configure rule events and alerts" on page 944](#)
- ["Set a schedule for the rule" on page 944](#)
- ["See policies and computers a rule is assigned to" on page 945](#)
- ["Assign a context to the rule " on page 944](#)

Add a new rule

There are three ways to add a new firewall rule on the **Policies > Common Objects > Rules > Firewall Rules** page. You can:

- Create a new rule. Click **New > New Firewall Rule**.
- Import a rule from an XML file. Click **New > Import From File**.
- Copy and then modify an existing rule. Right-click the rule in the Firewall Rules list and then click **Duplicate**. To edit the new rule, select it and then click **Properties**.

Select the behavior and protocol of the rule

1. Enter a **Name** and **Description** for the rule.

Tip: It is good practice to document all firewall rule changes in the Description field of the firewall rule. Make a note of when and why rules were created or deleted for easier firewall maintenance.

2. Select the **Action** that the rule should perform on packets. You can select from one of the following five actions:

Note: Only one rule action is applied to a packet, and rules (of the same priority) are applied in the order of precedence listed below.

- The rule can allow traffic to **bypass** the firewall. A bypass rule allows traffic to pass through the firewall and intrusion prevention engine at the fastest possible rate. Bypass rules are meant for traffic using media intensive protocols where filtering may not be desired or for traffic originating from trusted sources.

Tip: For an example of how to create and use a bypass rule for trusted sources in a policy, see ["Allow trusted traffic to bypass the firewall" on page 945](#).

Note: Bypass rules are unidirectional. Explicit rules are required for each direction of traffic.

Tip: You can achieve maximum throughput performance on a bypass rule with the following settings:

- **Priority:** Highest
 - **Frame Type:** IP
 - **Protocol:** TCP, UDP, or other IP protocol. (Do not use the "Any" option.)
 - **Source and Destination IP and MAC:** all "Any"
 - If the protocol is TCP or UDP and the traffic direction is "incoming", the destination ports must be one or more specified ports (not "Any"), and the source ports must be "Any".
 - If the protocol is TCP or UDP and the traffic direction is "outgoing", the source ports must be one or more specified ports (Not "Any"), and the destination ports must be "Any".
 - **Schedule:** None.
- The rule can **log only**. This action will make entries in the logs but will not process traffic.
 - The rule can **force allow** defined traffic (it will allow traffic defined by this rule without excluding any other traffic.)
 - The rule can **deny** traffic (it will deny traffic defined by this rule.)
 - The rule can **allow** traffic (it will exclusively allow traffic defined by this rule.)

Note: If you have no allow rules in effect on a computer, all traffic is permitted unless it is specifically blocked by a deny rule. Once you create a single allow rule, all other traffic is blocked unless it meets the requirements of the allow rule. There is one exception to this: ICMPv6 traffic is always permitted unless it is specifically blocked by a deny rule.

3. Select the **Priority** of the rule. The priority determines the order in which rules are applied. If you have selected "force allow", "deny", or "bypass" as your rule action, you can set a priority of 0 (low) to 4 (highest). Setting a priority allows you to combine the actions of rules to achieve a cascading rule effect.

Note: Log only rules can only have a priority of 4, and Allow rules can only have a priority of 0.

Note: High priority rules get applied before low priority rules. For example, a port 80 incoming deny rule with a priority of 3 will drop a packet before a port 80 incoming force allow rule with a priority of 2 gets applied to it.

For detailed information on how actions and priority work together, see "[Firewall rule actions and priorities](#)" on page 946.

4. Select a **Packet Direction**. Select whether this rule will be applied to **incoming** (from the network to the computer) or **outgoing** (from the computer to the network) traffic.

Note: An individual firewall rule only apply to a single direction of traffic. You may need to create incoming and outgoing firewall rules in pairs for specific types of traffic.

5. Select an Ethernet **Frame Type**. The term "frame" refers to Ethernet frames, and the available protocols specify the data that the frame carries. If you select "Other" as the frame type, you need to specify a [frame number](#).

6. **Note:** IP covers both IPv4 and IPv6. You can also select **IPv4** or **IPv6** individually

Note: On Solaris, Deep Security Agents will only examine packets with an IP frame type, and Linux Agents will only examine packets with IP or ARP frame types. Packets with other frame types will be allowed through. Note that the Virtual Appliance does not have these restrictions and can examine all frame types, regardless of the operating system of the virtual machine it is protecting.

If you select the Internet Protocol (IP) frame type, you need to select the transport **Protocol**.
If you select "Other" as the protocol, you also need to enter a [protocol number](#).

Select a Packet Source and Packet Destination

Select a combination of **IP** and **MAC** addresses, and if available for the frame type, **Port** and **Specific Flags** for the Packet Source and Packet Destination.

Tip: You can use a previously created [IP](#), [MAC](#) or [port](#) list.

Support for IP-based frame types is as follows:

	IP	MAC	Port	Flags
Any	✓	✓		
ICMP	✓	✓		✓
ICMPV6	✓	✓		✓
IGMP	✓	✓		
GGP	✓	✓		
TCP	✓	✓	✓	✓
PUP	✓	✓		
UDP	✓	✓	✓	
IDP	✓	✓		
ND	✓	✓		
RAW	✓	✓		
TCP+UDP	✓	✓	✓	✓

Note: ARP and REVARP frame types only support using MAC addresses as packet sources and destinations.

You can select **Any Flags** or individually select the following flags:

- URG
- ACK
- PSH
- RST
- SYN
- FIN

Configure rule events and alerts

When a firewall rule is triggered, it logs an event in the Deep Security Manager and records the packet data.

Note: Note that rules using the "Allow", "Force Allow" and "Bypass" actions will not log any events.

Alerts

You can configure rules to also trigger an alert if they log an event. To do so, open the properties for a rule, click on **Options**, and then select **Alert when this rule logs an event**.

Note: Only firewall rules with an action set to "Deny" or "Log Only" can be configured to trigger an alert.

Set a schedule for the rule

Select whether the firewall rule should only be active during a scheduled time.

For more information on how to do so, see ["Define a schedule that you can apply to rules" on page 797](#).

Assign a context to the rule

Rule contexts allow you to set firewall rules uniquely for different network environments. Contexts are commonly used to allow for different rules to be in effect for laptops when they are on and off-site.

For more information on how to create a context, see ["Define contexts for use in policies" on page 790](#).

Tip: For an example of a policy that implements firewall rules using contexts, look at the properties of the "Windows Mobile Laptop" Policy.

See policies and computers a rule is assigned to

You can see which policies and computers are assigned to a firewall rule on the **Assigned To** tab. Click on a policy or computer in the list to see their properties.

Export a rule

You can export all firewall rules to a .csv or .xml file by clicking **Export** and selecting the corresponding export action from the list. You can also export specific rules by first selecting them, clicking **Export** and then selecting the corresponding export action from the list.

Delete a rule

To delete a rule, right-click the rule in the Firewall Rules list, click **Delete** and then click **OK**.

Note: Firewall Rules that are assigned to one or more computers or that are part of a policy cannot be deleted.

Allow trusted traffic to bypass the firewall

You can set up Deep Security to allow trusted traffic to bypass the firewall.

To configure this, the basic steps are as follows:

1. ["Create a new IP list of trusted traffic sources" below](#)
2. ["Create incoming and outbound firewall rules for trusted traffic using the IP list" on the next page](#)
3. ["Assign the firewall rules to a policy used by computers that trusted traffic flows through" on the next page](#)

After the firewall rules have been assigned to a policy, Deep Security will allow traffic from trusted sources in the IP list and will not scan the traffic for stateful issues or vulnerabilities.

Create a new IP list of trusted traffic sources

1. Click **Policies**.
2. In the left pane, click **Lists > IP Lists**.
3. Click **New > New IP List**.

4. Enter a name for the IP list.
5. Paste the IP addresses for your trusted sources into the **IP(s)** box, one per line.
6. Click **OK**.

Create incoming and outbound firewall rules for trusted traffic using the IP list

1. Click **Policies**.
2. In the left pane, click **Rules**.
3. Click **Firewall Rules > New > New Firewall Rule**.
4. Create a firewall rule for incoming trusted traffic using the values in the below:

Name:	<i>source name</i> Traffic - Incoming
Action:	Bypass
Protocol:	Any
Packet Source:	IP List (select the IP list created above)

5. Create a firewall rule for outgoing trusted traffic using the values in the below:

Name:	<i>source name</i> Traffic - Outgoing
Action:	Bypass
Protocol:	Any
Packet Destination:	IP List (select the IP list created above)

Assign the firewall rules to a policy used by computers that trusted traffic flows through

1. Click **Policies**.
2. In the left pane, click **Policies**.
3. Double-click a policy to open its properties window.
4. In the left pane of the policy's properties window, click **Firewall**.
5. Click **Assign/Unassign**.
6. Ensure your view at the top left shows **All** firewall rules.
7. Use the search window to find the rules you created and select them.
8. Click **OK**.
9. Repeat the steps above for each computer that trusted traffic flows through.

Firewall rule actions and priorities

In this article:

- ["Firewall rule actions" below](#)
- ["Firewall rule sequence" on page 949](#)
- ["How firewall rules work together" on page 951](#)
- ["Rule priority" on page 953](#)
- ["Putting rule action and priority together" on page 953](#)

Firewall rule actions

Firewall rules can take the following actions:

- **Allow:** Explicitly allows traffic that matches the rule to pass, and then implicitly denies everything else.
- **Bypass:** Allows traffic to bypass both firewall and intrusion prevention analysis. Use this setting for media-intensive protocols or for traffic originating from trusted sources. A bypass rule can be based on IP, port, traffic direction, and protocol.
- **Deny:** Explicitly blocks traffic that matches the rule.
- **Force Allow:** Forcibly allows traffic that would otherwise be denied by other rules.

Note: Traffic permitted by a Force Allow rule will still be subject to analysis by the intrusion prevention module.

- **Log only:** Traffic will only be logged. No other action will be taken.

More about Allow rules

Allow rules have two functions:

1. Permit traffic that is explicitly allowed.
2. Implicitly deny all other traffic.

Note: Traffic that is not explicitly allowed by an Allow rule is dropped, and gets recorded as an 'Out of "Allowed" Policy' firewall event.

Commonly applied Allow rules include:

- **ARP:** Permits incoming Address Resolution Protocol (ARP) traffic .
- **Allow solicited TCP/UDP replies:** Allow the computer to receive replies to its own TCP and UDP messages. This works in conjunction with TCP and UDP stateful configuration.

- **Allow solicited ICMP replies:** Allow the computer to receive replies to its own ICMP messages. This works in conjunction with ICMP stateful configuration.

More about Bypass rules

The Bypass rule is designed for media-intensive protocols or for traffic originating from trusted sources where filtering by the firewall or intrusion prevention modules is neither required nor desired.

A packet that matches the conditions of a Bypass rule:

- Is not subject to conditions of stateful configuration settings.
- Bypasses both firewall and Intrusion prevention analysis.

Since stateful inspection is not applied to bypassed traffic, bypassing traffic in one direction does not automatically bypass the response in the other direction. Bypass rules should always be created and applied in pairs, one rule for incoming traffic and another for outgoing.

Note: Bypass rule events are not recorded. This is not a configurable behavior.

Tip: If the Deep Security Manager uses a remote database that is protected by a Deep Security Agent, intrusion prevention-related false alarms may occur when the Deep Security Manager saves intrusion prevention rules to the database. The contents of the rules themselves could be misidentified as an attack. One of the workarounds for this is to create a bypass rule for traffic from the Deep Security Manager to the database.

Default Bypass rule for Deep Security Manager traffic

The Deep Security Manager automatically implements a priority 4 Bypass rule that opens incoming TCP traffic on the agent's listening port for heartbeats (see "[Configure the heartbeat on page 1448](#)") on computers running Deep Security Agent. Priority 4 ensures that this rule is applied before any Deny rules, and Bypass guarantees that the traffic is never impaired. The Bypass rule is not explicitly shown in the firewall rule list because the rule is created internally.

This rule, however, accepts traffic from any IP address and any MAC address. To harden the agent's security on this port, you can create an alternative, more restrictive bypass rule for this port. The agent will actually disable the default Deep Security Manager traffic rule in favor of the new custom rule provided it has these characteristics:

- **Priority:** 4 - Highest
- **Packet direction:** Incoming
- **Frame type:** IP
- **Protocol:** TCP
- **Packet Destination Port:** agent's listening port number for heartbeats from the Manager

The custom rule must use the above parameters to replace the default rule. Ideally, the IP address or MAC address of the actual Deep Security Manager should be used as the packet source for the rule.

More about Force Allow rules

The Force Allow option excludes a sub-set of traffic that could otherwise have been covered by a Deny action. Its relationship to other actions is illustrated below. Force Allow has the same effect as a Bypass rule. However, unlike Bypass, traffic that passes the firewall because of this action is still subject to inspection by the intrusion prevention module. The Force Allow action is particularly useful for making sure that essential network services are able to communicate with the DSA computer. Generally, Force Allow rules should only be used in conjunction with Allow and rules to Allow a subset of traffic that has been prohibited by the Allow and Deny rules. Force Allow rules are also required to Allow unsolicited ICMP and UDP traffic when ICMP and UDP stateful are enabled.

Note: When using multiple Deep Security Managers in a multi-node arrangement, it may be useful to define an IP list for these servers, and then create a custom Deep Security Manager traffic rule with that list.

Firewall rule sequence

Packets arriving at a computer get processed first by firewall rules, then the firewall stateful configuration conditions, and finally by the intrusion prevention rules.

This is the order in which firewall rules are applied (incoming and outgoing):

1. Firewall rules with priority **4 (highest)**
 - a. **Bypass**
 - b. **Log Only** (Log Only rules can only be assigned a priority of **4 (highest)**)
 - c. **Force Allow**
 - d. **Deny**

2. Firewall rules with priority **3 (high)**
 - a. **Bypass**
 - b. **Force Allow**
 - c. **Deny**
3. Firewall rules with priority **2 (normal)**
 - a. **Bypass**
 - b. **Force Allow**
 - c. **Deny**
4. Firewall rules with priority **1 (low)**
 - a. **Bypass**
 - b. **Force Allow**
 - c. **Deny**
5. Firewall rules with priority **0 (lowest)**
 - a. **Bypass**
 - b. **Force Allow**
 - c. **Deny**
 - d. **Allow**(Note that an Allow rule can only be assigned a priority of **0 (lowest)**)

Note: If you have no Allow rules in effect on a computer, all traffic is permitted unless it is specifically blocked by a Deny rule. Once you create a single Allow rule, all other traffic is blocked unless it meets the conditions of the Allow rule. There is one exception to this: ICMPv6 traffic is always permitted unless it is specifically blocked by a Deny rule.

Within the same priority context, a Deny rule will override an Allow rule, and a Force Allow rule will override a Deny rule. By using the rule priorities system, a higher priority Deny rule can be made to override a lower priority Force Allow rule.

Consider the example of a DNS server policy that makes use of a Force Allow rule to Allow all [incoming DNS queries](#). Creating a Deny rule with a higher priority than the Force Allow rule lets you specify a particular range of IP addresses that must be prohibited from accessing the same public server.

Priority-based rule sets allow you set the order in which the rules are applied. If a Deny rule is set with the highest priority, and there are no Force Allow rules with the same priority, then any packet matching the Deny rule is automatically dropped and the remaining rules are ignored. Conversely, if a Force Allow rule with the highest priority flag set exists, any incoming packets matching the Force Allow rule will be automatically allowed through without being checked against any other rules.

A note on logging

Bypass rules will never generate an event. This is not configurable.

Log Only rules will only generate an event if the packet in question is not subsequently stopped by either:

- a Deny rule, or
- an Allow rule that excludes it.

If the packet is stopped by one of those two rules, those rules will generate the Event and not the Log Only rule. If no subsequent rules stop the packet, the Log Only rule will generate an event.

How firewall rules work together

Deep Security firewall rules have both a rule action and a rule priority. Used in conjunction, these two properties allow you to create very flexible and powerful rule-sets. Unlike rule-sets used by other firewalls, which may require that the rules be defined in the order in which they should be run, Deep Security Firewall rules are run in a deterministic order based on the rule action and the rule priority, which is independent of the order in which they are defined or assigned.

Rule Action

Each rule can have one of four actions.

1. **Bypass:** if a packet matches a Bypass rule, it is passed through both the firewall *and the Intrusion Prevention Engine* regardless of any other rule (at the same priority level).
2. **Log Only:** if a packet matches a Log Only rule it is passed and the event is logged.
3. **Force Allow:** if a packet matches a Force Allow rule it is passed regardless of any other rules (at the same priority level).
4. **Deny:** if a packet matches a Deny rule it is dropped.
5. **Allow:** if a packet matches an Allow rule, it is passed. Any traffic not matching one of the Allow rules is denied.

Implementing an Allow rule will cause all other traffic not specifically covered by the Allow rule to be denied:

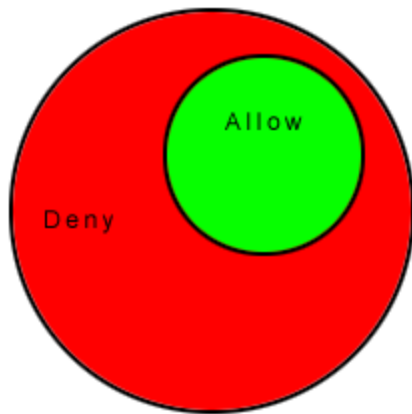

A Deny rule can be implemented over an Allow to block specific types of traffic:

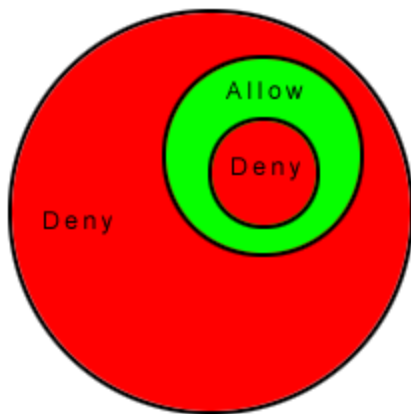

A Force Allow rule can be placed over the denied traffic to Allow certain exceptions to pass through:

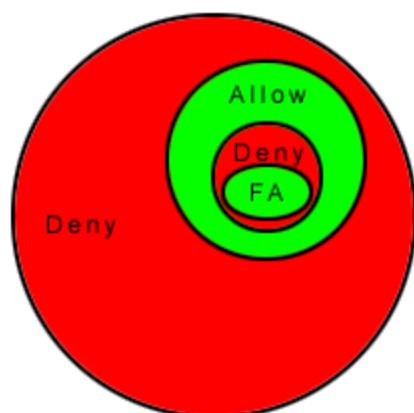

Rule priority

Rule actions of type Deny and Force Allow can be defined at any one of 5 priorities to allow further refinement of the permitted traffic defined by the set of Allow rules. Rules are run in priority order from highest (Priority 4) to lowest (Priority 0). Within a specific priority level the rules are processed in order based on the rule action (Force Allow, Deny, Allow, log only).

The priority context Allows a User to successively refine traffic controls using Deny and Force Allow rule combinations. Within the same priority context, an Allow rule can be negated with a Deny rule, and a Deny rule can be negated by a Force Allow rule.

Note: Rule actions of type Allow run only at priority 0 while rule actions of type Log Only run only at priority 4.

Putting rule action and priority together

Rules are run in priority order from highest (Priority 4) to lowest (Priority 0). Within a specific priority level the rules are processed in order based on the rule action. The order in which rules of equal priority are processed is as follows:

- Bypass
- Log Only
- Force Allow
- Deny
- Allow

Note: Remember that rule actions of type Allow run only at priority 0 while rule actions of type Log Only run only at priority 4.

Note: It is important to remember that if you have a Force Allow rule and a Deny rule at the same priority the Force Allow rule takes precedence over the Deny rule and therefore traffic matching the Force Allow rule will be permitted.

Firewall settings

The **Firewall** module provides bidirectional stateful firewall protection. It prevents denial of service attacks and provides coverage for all IP-based protocols and frame types as well as filtering for ports and IP and MAC addresses.

The Firewall section of the **Computer or Policy editor**¹ has the following tabbed sections:

- ["General" below](#)
- ["Interface Isolation" on page 956](#)
- ["Reconnaissance" on page 957](#)
- ["Advanced" on page 959](#)
- ["Firewall events" on page 959](#)

General

Firewall

You can configure this policy or computer to inherit its firewall On/Off state from its parent policy or you can lock the setting locally.

Firewall Stateful Configurations

Select which firewall stateful configuration to apply to this policy. If you have defined multiple Interfaces for this policy (above), you can specify independent configurations for each interface. For more information on creating a stateful configuration see ["Define stateful firewall configurations" on page 965](#).

¹You can change these settings for a policy or for a specific computer. To change the settings for a policy, go to the Policies page and double-click the policy that you want to edit (or select the policy and click Details). To change the settings for a computer, go to the Computers page and double-click the computer that you want to edit (or select the computer and click Details).

Port Scan (Computer Editor only)

Last Port Scan: The last time that the Deep Security manager ran a port scan on this computer.

Scanned Ports: The ports that were scanned during the most recent port scan.

Open Ports: Listed beneath the IP address of the local computer will be a list of ports that were found to be open.

The **Scan For Open Ports** and the **Cancel Port Scan** buttons let you initiate or cancel a port scan on this computer. Deep Security Manager will scan the range of ports defined in **Computer or Policy editor**¹ > **Settings** > **General** > **Open Ports** > **Ports to Scan**.

Note: Regardless of the ports configured to be scanned, Deep Security Manager will always scan the [agent or appliance's listening port number for heartbeat connections from the Manager](#).

Assigned Firewall Rules

Displays the firewall rules that are in effect for this policy or computer. To add or remove firewall rules, click **Assign/Unassign**. This will display a window showing all available firewall rules from which you can select or deselect rules.

From a **Computer or Policy editor**² window, you can edit a firewall rule so that your changes apply only locally in the context of your editor, or you can edit the rule so that the changes apply globally to all other policies and computers that are using the rule.

To edit the Rule locally, right-click the rule and click **Properties**.

To edit the Rule globally, right-click the rule and click **Properties (Global)**.

For more information on creating firewall rules, see "[Create a firewall rule](#)" on page 939.

¹You can change these settings for a policy or for a specific computer. To change the settings for a policy, go to the Policies page and double-click the policy that you want to edit (or select the policy and click Details). To change the settings for a computer, go to the Computers page and double-click the computer that you want to edit (or select the computer and click Details).

²You can change these settings for a policy or for a specific computer. To change the settings for a policy, go to the Policies page and double-click the policy that you want to edit (or select the policy and click Details). To change the settings for a computer, go to the Computers page and double-click the computer that you want to edit (or select the computer and click Details).

Interface Isolation

Interface Isolation

You can configure this policy or computer to inherit its Interface Isolation enabled or disabled state from its parent policy or you can lock the setting locally.

Warning: Before you enable Interface Isolation make sure that you have configured the interface patterns in the proper order and that you have removed or added all necessary string patterns. Only interfaces matching the highest priority pattern will be permitted to transmit traffic. Other interfaces (which match any of the remaining patterns on the list) will be "restricted". Restricted Interfaces will block all traffic unless an Allow Firewall Rule is used to allow specific traffic to pass through.

To configure the Interface Isolation policy:

1. On the Interface Isolation tab, select **Enable interface isolation**.
2. Configure the **Interface Patterns**. (See below)
3. Click **Save**.

Interface Patterns

When Interface Isolation is enabled, the firewall will try to match the regular expression patterns to interface names on the local computer.

Note: Deep Security uses POSIX basic regular expressions to match interface names. For information on basic POSIX regular expressions, see https://pubs.opengroup.org/onlinepubs/009695399/basedefs/xbd_chap09.html#tag_09_03

Only interfaces matching the highest priority pattern will be permitted to transmit traffic. Other interfaces (which match any of the remaining patterns on the list) will be "restricted". Restricted Interfaces will block all traffic unless an **Allow** firewall rule is used to allow specific traffic to pass through.

Selecting **Limit to one active interface** will restrict traffic to only a single interface (even if more than one interface matches the highest priority pattern).

Reconnaissance

Reconnaissance Scans

The **Reconnaissance** page allows you to enable and configure traffic analysis settings on your computers. This feature can detect possible reconnaissance scans that attackers often use to discover weaknesses before beginning a targeted attack.

Note: Reconnaissance scans do not work in TAP mode. Reconnaissance scans can only be detected on IPv4 traffic.

To enable reconnaissance protection, you must also enable the Firewall and Stateful Inspection on the **Computer or Policy editor**¹ > **Firewall** > **General** tab. You should also go to the **Computer or Policy editor**² > **Firewall** > **Advanced** tab and enable the **Generate Firewall Events for packets that are 'Out of Allowed Policy'** setting. This will generate firewall events that are required for reconnaissance.

When setting up Reconnaissance scans, you have the following options:

- **Reconnaissance Scan Detection Enabled:** Turn the ability to detect reconnaissance scans on or off. The default is all scans are enabled in report mode with notifications. If you want to turn off the notifications or switch from report mode to a temporary blocking mode, select **Yes** from the drop-list and make your changes.
- **Computers/Networks on which to perform detection:** Choose from the list the IPs to protect. Choose from existing IP Lists. (You can use the **Policies** > **Common Objects** > **Lists** > **IP Lists** page to create an IP List specifically for this purpose.)
- **Do not perform detection on traffic coming from:** Select from a set of IP Lists which computers and networks to ignore. (As above, you can use the **Policies** > **Common Objects** > **Lists** > **IP Lists** page to create an IP List specifically for this purpose.)

For each type of attack, the agent or appliance can be instructed to send the information to the Deep Security Manager where an alert will be triggered. You can configure the Deep Security

¹You can change these settings for a policy or for a specific computer. To change the settings for a policy, go to the Policies page and double-click the policy that you want to edit (or select the policy and click Details). To change the settings for a computer, go to the Computers page and double-click the computer that you want to edit (or select the computer and click Details).

²You can change these settings for a policy or for a specific computer. To change the settings for a policy, go to the Policies page and double-click the policy that you want to edit (or select the policy and click Details). To change the settings for a computer, go to the Computers page and double-click the computer that you want to edit (or select the computer and click Details).

Manager to send an email notification when the alerts are triggered. For more information, see **Administration > System Settings > Alerts**. Select **Notify DSM Immediately** for this option.

Note: For the "Notify DSM Immediately" option to work, the agents and appliances must be configured for **agent or appliance-initiated** or **bidirectional** communication in **Computer or Policy editor**¹ > **Settings > General**.) If enabled, the agent or appliance will initiate a heartbeat to the Deep Security Manager immediately upon detecting the attack or probe.

Once an attack has been detected, you can instruct the agents and appliances to block traffic from the source IPs for a period of time. Use the **Block Traffic** drop-down lists to set the number of minutes.

The alerts are:

- **Computer OS Fingerprint Probe:** The agent or appliance detects an attempt to discover the computers OS.
- **Network or Port Scan:** The agent or appliance reports a network or port scan if it detects that a remote IP is visiting an abnormal ratio of IPs to ports. Normally, an agent or appliance computer will only see traffic destined for itself, so a port scan is the most common type of probe that will be detected. The statistical analysis method used in computer or port scan detection is derived from the "TAPS" algorithm proposed in the paper "Connectionless Port Scan Detection on the Backbone" presented at IPCCC in 2006.
- **TCP Null Scan:** The agent or appliance detects packages with no flags set.
- **TCP SYNFIN Scan:** The agent or appliance detects packets with only the SYN and FIN flags set.
- **TCP Xmas Scan:** The agent or appliance detects packets with only the FIN, URG, and PSH flags set or a value of 0xFF (every possible flag set).

Note: "Network or Port Scans" differs from the other types of reconnaissance in that it cannot be recognized by a single packet and requires Deep Security to watch traffic for a period of time.

The agent or appliance reports a computer or port scan if it detects that a remote IP is visiting

¹You can change these settings for a policy or for a specific computer. To change the settings for a policy, go to the Policies page and double-click the policy that you want to edit (or select the policy and click Details). To change the settings for a computer, go to the Computers page and double-click the computer that you want to edit (or select the computer and click Details).

an abnormal ratio of IPs to ports. Normally an agent or appliance computer will only see traffic destined for itself, so a port scan is by far the most common type of probe that will be detected. However, if a computer is acting as a router or bridge it could see traffic destined for a number of other computers, making it possible for the agent or appliance to detect a computer scan (ex. scanning a whole subnet for computers with port 80 open).

Detecting these scans can take several seconds since the agent or appliance needs to be able to track failed connections and decide that there are an abnormal number of failed connections coming from a single computer in a relatively short period of time.

Note: Deep Security Agents running on Windows computers with browser applications may occasionally report false-positive reconnaissance scans due to residual traffic arriving from closed connections.

For information on how to handle reconnaissance warnings, see "[Warning: Reconnaissance Detected](#)" on page 1402.

Advanced

Events

Set whether to generate events for packets that are "Out of Allowed Policy". These are packets that have been blocked because they have not been specifically allowed by an **Allow** firewall rule. Setting this option to **Yes** may generate a large number of events depending on the firewall rules you have in effect.

Firewall events

Firewall events are displayed the same way as they are in the main Deep Security Manager window except that only events relating to this policy or specific computer are displayed.

Firewall settings with Oracle RAC

Deep Security supports Oracle RAC. For a list of supported versions of Oracle RAC, see "[Software requirements](#)" on page 435.

The default Linux Server Deep Security policy is compatible with the Oracle RAC environment, with the exception of firewall settings. Because there are complex communication channels between RAC nodes, the RAC nodes will fail to create a virtual NIC and scan the NIC, due to

firewall interference. As a result, Oracle Clusterware would fail to start on some nodes. You can disable the firewall or customize the firewall settings.

Add a rule to allow communication between nodes

1. In the Deep Security Manager, go to the **Policies** tab.
2. Right-click the **Linux Server** policy and click **Duplicate**.
3. Click the new **Linux Server_2** policy and click **Details**.
4. Give the policy a new name, for example, "Oracle RAC" and click **Save**.
5. Click **Firewall**.
6. Click **Assign/Unassign**.
7. Click **New > New Firewall Rule**.
8. Under **General Information**, set the **Name** to something descriptive, like "Allow communication with Oracle nodes". Set **Action** to "Force Allow" and set **Protocol** to "Any".
9. Under **Packet Source**, set **MAC** to "MAC List". In the **Select MAC List** that appears, select "New". A "New MAC List Properties" dialog box appears.
10. Give the MAC list a name, like "Oracle RAC MAC list". Under **MAC(s): (One MAC per line)**, add all of the MAC addresses used by all Oracle nodes (including MACs from both private and public NICs). Click **OK** when finished.
11. Under **Packet Destination**, set **MAC** to "MAC List". In the **Select MAC List** that appears, select the MAC list you created in step 10 and then click **OK**.
12. In the Firewall Rules list for the policy, ensure that this new rule is selected and click **OK** and then click **Save**.

Add a rule to allow UDP port 42424

Follow the steps described in the procedure above to add a new rule that allows UDP port 42424. This [port number](#) is used by the Cluster Synchronization Service daemon (CSSD), Oracle Grid Interprocess Communication (GIPCD) and Oracle HA Services daemon (OHASD).

Note: Please note that the MAC list that you created above may not be able to cover this rule. This rule is essential for Oracle RAC.

General	Options	Assigned To
General Information		
Name:	<input type="text" value="New Firewall Rule"/>	
Description:	<input type="text"/>	
Action:	<input type="text" value="Force Allow"/>	
Priority:	<input type="text" value="0 - Lowest"/>	
Packet direction:	<input type="text" value="Incoming"/>	
Frame Type:	<input type="text" value="IP"/>	<input type="checkbox"/> Not
Protocol:	<input type="text" value="UDP"/>	<input type="checkbox"/> Not
Packet Source		
IP:	<input type="text" value="Any"/>	<input type="checkbox"/> Not
MAC:	<input type="text" value="Any"/>	<input type="checkbox"/> Not
Port:	<input type="text" value="Any"/>	<input type="checkbox"/> Not
Packet Destination		
IP:	<input type="text" value="Any"/>	<input type="checkbox"/> Not
MAC:	<input type="text" value="Any"/>	<input type="checkbox"/> Not
Port:	<input type="text" value="Port(s):"/> <input type="text" value="42424"/>	<input type="checkbox"/> Not
		<input type="button" value="OK"/> <input type="button" value="Cancel"/>

Allow other RAC-related packets

Oracle RAC will send a very large number of packets with Frame Type C08A and 0ACB. Blocking them may cause some unpredictable behavior.

- **Allow TCP post 6200:** Add the public IP addresses of the RAC nodes in the **IP** fields under **Packet Source** and **Packet Destination** and set destination port to 6200. This [port number](#) is used by Oracle Notification Services (ONS). This port is configurable, so check the value on your system set the correct port number if it is something other than 6200.

The screenshot shows a configuration window with three tabs: 'General', 'Options', and 'Assigned To'. The 'General' tab is active. The window is divided into two main sections: 'General Information' and 'Packet Source'.

General Information:

- Name: RAC_TCP 6200_suse
- Description: (Empty text area)
- Action: Allow
- Priority: 0 - Lowest
- Packet direction: Incoming
- Frame Type: IP (with a radio button labeled 'Not')
- Protocol: TCP (with a radio button labeled 'Not')

Packet Source:

- IP: Any (with a radio button labeled 'Not')
- MAC: Any (with a radio button labeled 'Not')
- Port: Port(s): 6200 (with a radio button labeled 'Not')

At the bottom right, there are 'OK' and 'Cancel' buttons.

- **Allow Frame Type C0A8:** Add a rule with the **Frame Type** set to "Other" and the **Frame no** set to "C0A8".

The screenshot shows a configuration window with three tabs: 'General', 'Options', and 'Assigned To'. The 'General' tab is active, displaying 'General Information'. The 'Name' field is 'RAC_C0A8'. The 'Description' field is empty. The 'Action' is set to 'Allow', 'Priority' to '0 - Lowest', and 'Packet direction' to 'Incoming'. The 'Frame Type' is 'Other', and the 'Frame no' is 'CA08'. There are two unchecked checkboxes labeled 'Not'. The 'Protocol' is set to 'Any'. 'OK' and 'Cancel' buttons are at the bottom right.

- **Allow Frame Type 0ACB:** Add a rule with the **Frame Type** set to "Other" and the **Frame no** set to "0ACB".
- **Allow Frame Type 0AC9:** Add a rule with the **Frame Type** set to "Other" and the **Frame no** set to "0AC9".

- **Allow IGMP protocol:** Add a rule with the Protocol set to "IGMP".

The screenshot shows a configuration window for a firewall rule. The 'General' tab is active. Under 'General Information', the 'Name' field contains 'RAC_allow_IGMP'. The 'Description' field is empty. The 'Action' is set to 'Allow', 'Priority' is '0 - Lowest', and 'Packet direction' is 'Incoming'. The 'Frame Type' is 'IP' and the 'Protocol' is 'IGMP'. There are two checkboxes labeled 'Not' on the right side of the 'Frame Type' and 'Protocol' fields, both of which are unchecked. The 'OK' and 'Cancel' buttons are located at the bottom right of the window.

Please refer to the following link to check whether there are additional RAC-related components in your system that need extra firewall rules to allow certain ports:

<https://docs.oracle.com/database/121/RILIN/ports.htm#RILIN1178>

Ensure that the Oracle SQL Server rule is assigned

Check that the "Oracle SQL Server" Firewall rule is assigned to the Linux Server policy. This is a pre-defined Deep Security Firewall rule that allows port 1521.

Ensure that anti-evasion settings are set to "Normal"

In the properties for the Linux Server policy, **Settings > Network Engine > Anti-Evasion Settings** are set to "Normal" by default. If this setting is set to "Strict", the RAC database response will be extremely slow.

Policy: Base Policy > Linux Server ? Help

Overview | **General** | **Advanced** | Scanner | SIEM

Network Engine Mode

Network Engine Mode: Inherited (Inline)

NOTE Firewall, Intrusion Prevention, and Web Reputation operate in Detect-only mode when the Network Engine is in Tap mode.

Events

Maximum size of the event log files (on Agent/Appliance): Inherited (4 MB)

Number of event log files to retain (on Agent/Appliance): Inherited (3)

Do not record events with source IP of: Inherited (None)

Cache Size: Inherited (128)

Cache Lifetime: Inherited (30 Minutes)

Cache Stale time: Inherited (15 Minutes)

Anti-Evasion Settings

Security Posture: Inherited (Normal)

NOTE Anti-Evasion settings control the network engine handling of abnormal packets that may be attempting to evade analysis. Normal mode is tuned to prevent evasion of IPS rules without false positives. Strict mode performs more stringent checking but could result in some false-positive results. Custom mode enables you to specify how Anti-Evasion checking is performed.

Define stateful firewall configurations

Deep Security's stateful firewall configuration mechanism analyzes each packet in the context of traffic history, correctness of TCP and IP header values, and TCP connection state transitions. In the case of stateless protocols like UDP and ICMP, a pseudo-stateful mechanism is implemented based on historical traffic analysis. Packets are handled by the stateful mechanism as follows:

1. A packet is passed to the stateful routine if it has been allowed through by the static firewall rule conditions,
2. The packet is examined to determine whether it belongs to an existing connection, and
3. The TCP header is examined for correctness (e.g. sequence numbers, flag combinations, etc.).

To create a new stateful configuration, you need to:

1. ["Add a stateful configuration "](#) on the next page.
2. ["Enter stateful configuration information"](#) on the next page.
3. ["Select packet inspection options"](#) on the next page.

When you're done with your stateful configuration, you can also learn how to

- ["See policies and computers a stateful configuration is assigned to"](#) on page 970
- ["Export a stateful configuration "](#) on page 970

- ["Delete a stateful configuration "](#) on page 970

Add a stateful configuration

There are three ways to define a stateful configuration on the **Policies > Common Objects > Other > Firewall Stateful Configurations** page:

- Create a new configuration. Click **New > New Firewall Stateful Configuration**.
- Import a configuration from an XML file. Click **New > Import From File**.
- Copy and then modify an existing configuration. Right-click the configuration in the Firewall Stateful Configurations list and then click **Duplicate**. To edit the new configuration, select it and then click **Properties**.

Enter stateful configuration information

Enter a **Name** and **Description** for the configuration.

Select packet inspection options

You can define options for IP, TCP, UDP and ICMP packet inspection, and enable Active or Passive FTP.

IP packet inspection

Under the **General** tab, select the **Deny all incoming fragmented packets** to drop any fragmented packets. Dropped packets will bypass fragmentation analysis and generate an "IP fragmented packet" log entry. Packets with a total length smaller than the IP header length are dropped silently.

Warning: Attackers sometimes create and send fragmented packets in an attempt to bypass Firewall Rules.

Note: The Firewall Engine, by default, performs a series of checks on fragmented packets. This is default behavior and cannot be reconfigured. Packets with the following characteristics are dropped:

- **Invalid fragmentation flags/offset:** A packet is dropped when either the **DF** and **MF** flags in the IP header are set to 1, or the header contains the **DF** flag set to 1 and an **Offset** value different than 0.

- **First fragment too small:** A packet is dropped if its **MF** flag is set to 1, its **Offset** value is at 0, and it has total length of less than 120 bytes (the maximum combined header length).
- **IP fragment out of boundary:** A packet is dropped if its **Offset** flag value combined with the total packet length exceeds the maximum datagram length of 65535 bytes.
- **IP fragment offset too small:** A packet is dropped if it has a non-zero **Offset** flag with a value that is smaller than 60 bytes.

TCP packet inspection

Under the **TCP** tab, select which of the following options you would like to enable:

- **Deny TCP packets containing CWR, ECE flags:** These flags are set when there is network congestion.

Note: RFC 3168 defines two of the six bits from the Reserved field to be used for ECN (Explicit Congestion Notification), as follows:

- Bits 8 to 15: CWR-ECE-URG-ACK-PSH-RST-SYN-FIN
- TCP Header Flags Bit Name Reference:
 - Bit 8: CWR (Congestion Window Reduced) [RFC3168]
 - Bit 9: ECE (ECN-Echo) [RFC3168]

Warning: Automated packet transmission (such as that generated by a denial of service attack, among other things) will often produce packets in which these flags are set.

- **Enable TCP stateful inspection:** Enable stateful inspection at the TCP level. If you enable stateful TCP inspection, the following options become available:
 - **Enable TCP stateful logging:** TCP stateful inspection events will be logged.
 - **Limit the number of incoming connections from a single computer to:** Limiting the number of connections from a single computer can lessen the effect of a denial of service attack.
 - **Limit the number of outgoing connections to a single computer to:** Limiting the number of outgoing connections to a single computer can significantly reduce the effects of Nimda-like worms.

- **Limit the number of half-open connections from a single computer to:** Setting a limit here can protect you from DoS attacks like SYN Flood. Although most servers have timeout settings for closing half-open connections, setting a value here can prevent half-open connections from becoming a significant problem. If the specified limit for SYN-SENT (remote) entries is reached, subsequent TCP packets from that specific computer will be dropped.

Note: When deciding on how many open connections from a single computer to allow, choose your number from somewhere between what you would consider a reasonable number of half-open connections from a single computer for the type of protocol being used, and how many half-open connections from a single computer your system can maintain without getting congested.

- **Enable ACK Storm protection when the number of already acknowledged packets exceeds:** Set this option to log an event that an ACK Storm attack has occurred.
 - **Drop Connection when ACK Storm detected:** Set this option to drop the connection if such an attack is detected.

Note: ACK Storm protection options are only available on Deep Security Agent 8.0 and earlier.

FTP Options

Under the **FTP Options** tab, you can enable the following options:

Note: The following FTP options are available in Deep Security Agent version 8.0 and earlier.

- **Active FTP**
 - **Allow Incoming:** Allow Active FTP when this computer is acting as a server.
 - **Allow Outgoing:** Allow Active FTP when this computer is acting as client.
- **Passive FTP**
 - **Allow Incoming:** Allow Passive FTP when this computer is acting as a server.
 - **Allow Outgoing:** Allow Passive FTP when this computer is acting as a client.

UDP packet inspection

Under the **UDP** tab, you can enable the following options:

- **Enable UDP stateful inspection:** Select to enable stateful inspection of UDP traffic.

Note: The UDP stateful mechanism drops unsolicited incoming UDP packets. For every outgoing UDP packet, the rule will update its UDP "stateful" table and will then only allow a UDP response if it occurs within 60 seconds of the request. If you wish to allow specific incoming UDP traffic, you will have to create a **Force Allow** rule. For example, if you are running a DNS server, you will have to create a **Force Allow** rule to allow incoming UDP packets to destination port 53.

Warning: Without stateful inspection of UDP traffic, an attacker can masquerade as a DNS server and send unsolicited UDP "replies" from source port 53 to computers behind a firewall.

- **Enable UDP stateful logging:** Selecting this option will enable the logging of UDP stateful inspection events.

ICMP packet inspection

Under the **ICMP** tab, you can enable the following options:

Note: ICMP stateful inspection is available in Deep Security Agent version 8.0 or earlier.

- **Enable ICMP stateful inspection:** Select to enable stateful inspection of ICMP traffic.

Note: The ICMP (pseudo-)stateful mechanism drops incoming unsolicited ICMP packets. For every outgoing ICMP packet, the rule will create or update its ICMP "stateful" table and will then only allow a ICMP response if it occurs within 60 seconds of the request. (ICMP pair types supported: Type 0 & 8, 13 & 14, 15 & 16, 17 & 18.)

Warning: With stateful ICMP inspection enabled, you can, for example, only allow an ICMP echo-reply in if an echo-request has been sent out. Unrequested echo-replies could be a sign of several kinds of attack including a Smurf amplification attack, a Tribe Flood Network communication between master and daemon, or a Loki 2 back-door.

- **Enable ICMP stateful logging:** Selecting this option will enable the logging of ICMP stateful inspection events.

Export a stateful configuration

You can export all stateful configurations to a .csv or .xml file by clicking **Export** and selecting the corresponding export action from the list. You can also export specific stateful configurations by first selecting them, clicking **Export** and then selecting the corresponding export action from the list.

Delete a stateful configuration

To delete a stateful configuration, right-click the configuration in the Firewall Stateful Configurations list, click **Delete** and then click **OK**.

Note: Stateful configurations that are assigned to one or more computers or that are part of a policy cannot be deleted.

See policies and computers a stateful configuration is assigned to

You can see which policies and computers are assigned to a stateful inspection configuration on the **Assigned To** tab. Click on a policy or computer in the list to see their properties.

Scan for open ports

The Deep Security Manager can be instructed to scan a computer for open ports by right-clicking the computer and selecting **Actions > Scan for Open ports**, or by clicking the **Scan for Open Ports** button in the **Firewall** page of the **Computer editor**¹ window (where the results of the latest scan are displayed).

(Port scans can also be initiated by right-clicking an existing computer on the Manager's **Computers** page and choosing "Scan for Open Ports". Another way to initiate port scans is to create a **Scheduled Task** to regularly carry out port scans on a list of computers.)

By default, the range of ports that are scanned is the range known as the "Common Ports", 1-1024, but you can define a different set of ports to scan.

Note: [The agent's port number for incoming heartbeat connections from the Manager](#) is always scanned regardless of port range settings. It is the port on the computer to which communications initiated by the Manager are sent. If communication direction is set to

¹To open the Computer editor, go to the Computers page and double-click the computer that you want to edit (or select the computer and click Details).

"Agent/Appliance Initiated" for a computer ([Computer or Policy editor](#)¹ > Settings > General), however, that port number will be closed.

1. Go to **Policies > Common Objects > Lists > Port Lists** and click **New** in the menu bar. The **New Port List** window will appear.
2. Type a name and description for the new port list and then define the ports in the **Port(s)** text box using the accepted formats. (For example, to scan ports 100, 105, and 110 through 120, you would type "100" on the first line "105" on the second, and "110-120" on the third.) Click **OK**.
3. Go to [Computer or Policy editor](#)² > Settings > General and click the "Ports to Scan" menu. Your newly defined Port List will be one of the choices.

Container Firewall rules

If you are using Deep Security Agent 11.2 or higher to protect containers that use an overlay network, you may need to add some Firewall rules to allow network traffic for the Swarm or Kubernetes services because the default Firewall rules block that traffic.

Kubernetes Firewall rules

If you are using Kubernetes, add the following rules to bypass the k8s communication traffic and export service traffic:

Name	Action Type	Priority	Direction	Frame Type	Protocol	Source IP	Source Port	Destination IP	Destination Port
HTTP incoming TCP 80 destination port	Force Allow	0 - Lowest	Incoming	IP	TCP	Any	N/A	Any	80
HTTP outgoing TCP 80	Force Allow	0 - Lowest	Outgoing	IP	TCP	Any	80	Any	Any

¹You can change these settings for a policy or for a specific computer. To change the settings for a policy, go to the Policies page and double-click the policy that you want to edit (or select the policy and click Details). To change the settings for a computer, go to the Computers page and double-click the computer that you want to edit (or select the computer and click Details).

²You can change these settings for a policy or for a specific computer. To change the settings for a policy, go to the Policies page and double-click the policy that you want to edit (or select the policy and click Details). To change the settings for a computer, go to the Computers page and double-click the computer that you want to edit (or select the computer and click Details).

Name	Action Type	Priority	Direction	Frame Type	Protocol	Source IP	Source Port	Destination IP	Destination Port
source port									
K8s incoming TCP 10054 port	Force Allow	0 - Lowest	Incoming	IP	TCP	Any	Any	Any	10054
K8s outgoing TCP 10054 port	Force Allow	0 - Lowest	Outgoing	IP	TCP	Any	Any	Any	10054
K8s outgoing TCP 443 port	Force Allow	0 - Lowest	Outgoing	IP	TCP	Any	Any	Any	443
K8s outgoing TCP 6443 port	Force Allow	0 - Lowest	Incoming	IP	TCP	Any	Any	Any	6443
K8s outgoing TCP 6443 port	Force Allow	0 - Lowest	Outgoing	IP	TCP	Any	Any	Any	6443
K8s outgoing TCP 8081 port	Force Allow	0 - Lowest	Incoming	IP	TCP	Any	Any	Any	8081
K8s outgoing TCP 8081 port	Force Allow	0 - Lowest	Outgoing	IP	TCP	Any	Any	Any	8081
K8s outgoing UDP 8472 port	Force Allow	0 - Lowest	Outgoing	IP	UDP	Any	Any	Any	8472
K8s outgoing UDP 8285 port	Force Allow	0 - Lowest	Outgoing	IP	UDP	Any	Any	Any	8285
K8s outgoing UDP 8285 port	Force Allow	0 - Lowest	Incoming	IP	UDP	Any	Any	Any	8285

Swarm Firewall rules

If you are using Swarm, add the following rules to bypass the k8s communication traffic and export service traffic:

Name	Action Type	Priority	Direction	Frame Type	Protocol	Source IP	Source Port	Destination IP	Destination Port
HTTP incoming TCP 80 destination port	Force Allow	0 - Lowest	Incoming	IP	TCP	Any	N/A	Any	80
HTTP outgoing TCP 80 source port	Force Allow	0 - Lowest	Outgoing	IP	TCP	Any	80	Any	Any
Swarm outgoing TCP 443 port	Force Allow	0 - Lowest	Outgoing	IP	TCP	Any	Any	Any	443
Swarm incoming TCP 2377, 4789, 7946, 60012 port	Force Allow	0 - Lowest	Incoming	IP	TCP+UDP	Any	Any	Any	2377, 4789, 7946, 60012
Swarm outgoing TCP 2377, 4789, 7946, 60012 port	Force Allow	0 - Lowest	Outgoing	IP	TCP+UDP	Any	2377, 4789, 7946, 60012	Any	Any

Configure Device Control

About Device Control

The Device Control module regulates access to external storage devices that are connected to computers. Device Control helps prevent data leaks and, combined with file scanning, helps guard against security risks.

Device Control's enforcement setting (in a policy or computer's **Device Control** tab) can be set to three options for each supported device type which from unlimited to restricted is "Full-Access", "Read-Only", and "Block".

Actions against a specific device type will be taken when that type of device is connected to the protected endpoint. If a user's action triggers the violation, Device Control events will be sent to Deep Security Console (in **Events & Reports > Events > Device Control Events**).

[Exceptions](#) can be added to a policy or a computer (in the computer's **Device Control tab > Exceptions**) to allow for full access for the device even when the action is set to "Read-Only" or "Block".

To enable and configure Device Control, see [Set up Device Control](#).

Device Control protocols

Actions against device type

When Device Control is enabled, each device type is assigned a "protocol," the permissions users have when they access it.

Protocol	Read	Copy	Exclude	Write	Delete
Full-Access	✓	✓	✓	✓	✓
Read-Only	✓	✓	✗	✗	✗
Block	✗	✗	✗	✗	✗

USB Autorun

Device Control allows you to prevent the execution of USB autorun when a USB device is connected to a computer.

Set up Device Control

1. Go to **Policies**. (Alternatively, to enable it on a specific computer, go to the computer's **Device Control** tab.)
2. Double-click the policy for which you want to enable Device Control.
3. Select **Device Control > General**.
4. For **Device Control State**, select **On**.
5. Select **Save**.

Configure protocols

The following table shows available action settings for each device type.

	Available setting	Description
USB Mass Storage Note: This feature is supported by Deep Security Agent 20.0.0-4959+ for Windows.	<ul style="list-style-type: none"> • Full Access • Read Only • Block 	Configure access policy of USB devices
USB AutoRun Function	<ul style="list-style-type: none"> • Allow • Block 	Allow or block USB device auto run
Mobile (MTP/PTP) Note: This is not currently supported by the agent for Windows Server Core.	<ul style="list-style-type: none"> • Allow • Block 	Configure access policy of USB mobile device

Configure USB Device Exceptions

Create new device

To allow access to specific USB devices when USB Mass Storage is set to "Block" or "Read Only", set exception rules.

For each exception rule, type a name, then specify "Vendor", "Model" and "Serial Number".

An access violation will be bypassed if the access matches the "Vendor," "Model," and "Serial Number" in exception rules.

For information on USB devices, visit this page:

https://success.trendmicro.com/dcx/s/solution/000286159?language=en_US

Select existing devices

Existing devices can appear in multiple policies. To include existing devices in a policy, click ****Select existing devices in lists**** and select the relevant devices.

Device Control event tagging

The events generated by the Device Control module are displayed in the Deep Security console, under **Events & Reports > Device Control Events**. Event tagging can help you to sort events and determine which events need to be investigated further and which events are legitimate.

You can manually apply tags to events by right-clicking the event and then clicking **Add Tag(s)**. You can choose to apply the tag to only the selected event or to any similar Device Control events.

You can also use the auto-tagging feature to group and label multiple events. To configure this feature in the Deep Security console, go to **Events and Reports > Device Control Events > Auto-Tagging > New Trusted Source**. There are three sources that you can use to perform the tagging:

- A Local Trusted Computer.
- The Trend Micro Certified Safe Software Service.
- A Trusted Common Baseline, which is a set of file states collected from a group of computers.

For more information on event tagging, see [Apply tags to identify and group events](#).

Configure Integrity Monitoring

About Integrity Monitoring

The integrity monitoring module scans for unexpected changes to registry values, registry keys, services, processes, installed software, ports and files on Deep Security Agents. Using a baseline secure state as a reference, the integrity monitoring module performs scans on the above and logs an event (and an optional alert) if it detects any unexpected changes.

To enable and configure integrity monitoring, see ["Set up Integrity Monitoring" below](#).

To more information on creating integrity monitoring rules, see ["Create an Integrity Monitoring rule" on page 985](#). You can create a rule from a file or registry monitoring template, or by using the Deep Security XML-based ["About the Integrity Monitoring rules language" on page 989](#).

Set up Integrity Monitoring

The Integrity Monitoring protection module detects changes to files and critical system areas like the Windows registry that could indicate suspicious activity. It does this by comparing current conditions to a baseline reading it has previously recorded. Deep Security ships with predefined Integrity Monitoring rules and new Integrity Monitoring rules are provided in security updates.

Note: Integrity Monitoring detects changes made to the system, but will not prevent or undo the changes.

How to enable Integrity Monitoring

You can enable Integrity Monitoring in policies or at the computer level. To do so, you will need to:

1. ["Turn on Integrity Monitoring" on the next page](#).
2. ["Run a Recommendation scan" on page 979](#).
3. ["Apply the Integrity Monitoring rules" on page 979](#).
4. ["Build a baseline for the computer" on page 981](#).
5. ["Periodically scan for changes" on page 981](#).
6. ["Test Integrity Monitoring" on page 981](#).

Once you've enabled Integrity Monitoring, you can also learn more about:

- "When Integrity Monitoring scans are performed" on page 982
- "Integrity Monitoring scan performance settings" on page 983
- "Integrity Monitoring event tagging" on page 984

The following is a typical procedure for enabling Integrity Monitoring:

Turn on Integrity Monitoring

You can enable Integrity Monitoring in the settings for a computer or in policies. To do this, open the Policy or Computer editor and go to **Integrity Monitoring > General**. Set the Configuration to "On" or "Inherited (On)" and then click **Save**.

Computer: laptop_adaggs (lap) ? Help

Overview | **Integrity Monitoring** | Log Inspection | Interfaces | Settings | Updates | Overrides

General | Advanced | Events

Integrity Monitoring

Configuration: Inherited (On)

State: ● On, matching module plug-in not found, 28 rules

Enable real-time scan

Real Time

Integrity Scan

Last Full Scan For Integrity: N/A

Scan For Integrity

Baseline

Last Integrity Baseline Created: N/A

Rebuild Baseline View Baseline

Assigned Integrity Monitoring Rules

Assign/Unassign... Properties... Export Columns...

NAME ^	SEVERIT...	TYPE	LAST UPDAT...
● 1002767 - Microsoft Windows - ...	● High	Defined	July 28, 2009
● 1002773 - Microsoft Windows - ...	● High	Defined	May 25, 2010
● 1002774 - Microsoft Windows - ...	● Medium	Defined	June 23, 2009
● 1002775 - Microsoft Windows - ...	● High	Defined	July 14, 2009

Recommendations

Current Status: 28 Integrity Monitoring Rule(s) assigned

Last Scan for Recommendations: N/A

i No Recommendation Scan Results

Automatically implement Integrity Monitoring Rule Recommendations (when possible): Inherited (No)

Scan For Recommendations Cancel Recommendation Scan Clear Recommendations

Save Close

Run a Recommendation scan

Run a Recommendation scan on the computer to get recommendations about which rules would be appropriate. To do this, open the Computer editor and go to **Integrity Monitoring > General**. In the Recommendations section, click **Scan for Recommendations**. You can optionally specify that Deep Security should implement the rule recommendations that it finds.

Recommended Integrity Monitoring rules may result in too many monitored entities and attributes. The best practice is to decide what is critical and should be monitored, then create custom rules or tune the predefined rules. Pay extra attention to rules that monitor frequently-changed properties such as process IDs and source port numbers because they can be noisy and may need some tuning.

If you have enabled real-time integrity monitoring scans and find that some recommended rules produce too many events because they are monitoring directories that change frequently, you can disable real-time scanning for those rules. Go to **Policies > Common Objects > Rules > Integrity Monitoring Rules** and double-click the rule. On the **Options** tab, clear the **Allow Real Time Monitoring** checkbox.

Apply the Integrity Monitoring rules

As described above, when you run a Recommendation scan, you can have Deep Security implement the recommended rules automatically. You can also manually assign rules.

In the Computer or Policy editor, go to **Integrity Monitoring > General**. The "Assigned Integrity Monitoring Rules" section displays the rules that are in effect for this policy or computer. To add or remove Integrity Monitoring Rules, click **Assign/Unassign**. This will display a window showing all available Integrity Monitoring Rules, from which you can select or deselect rules.

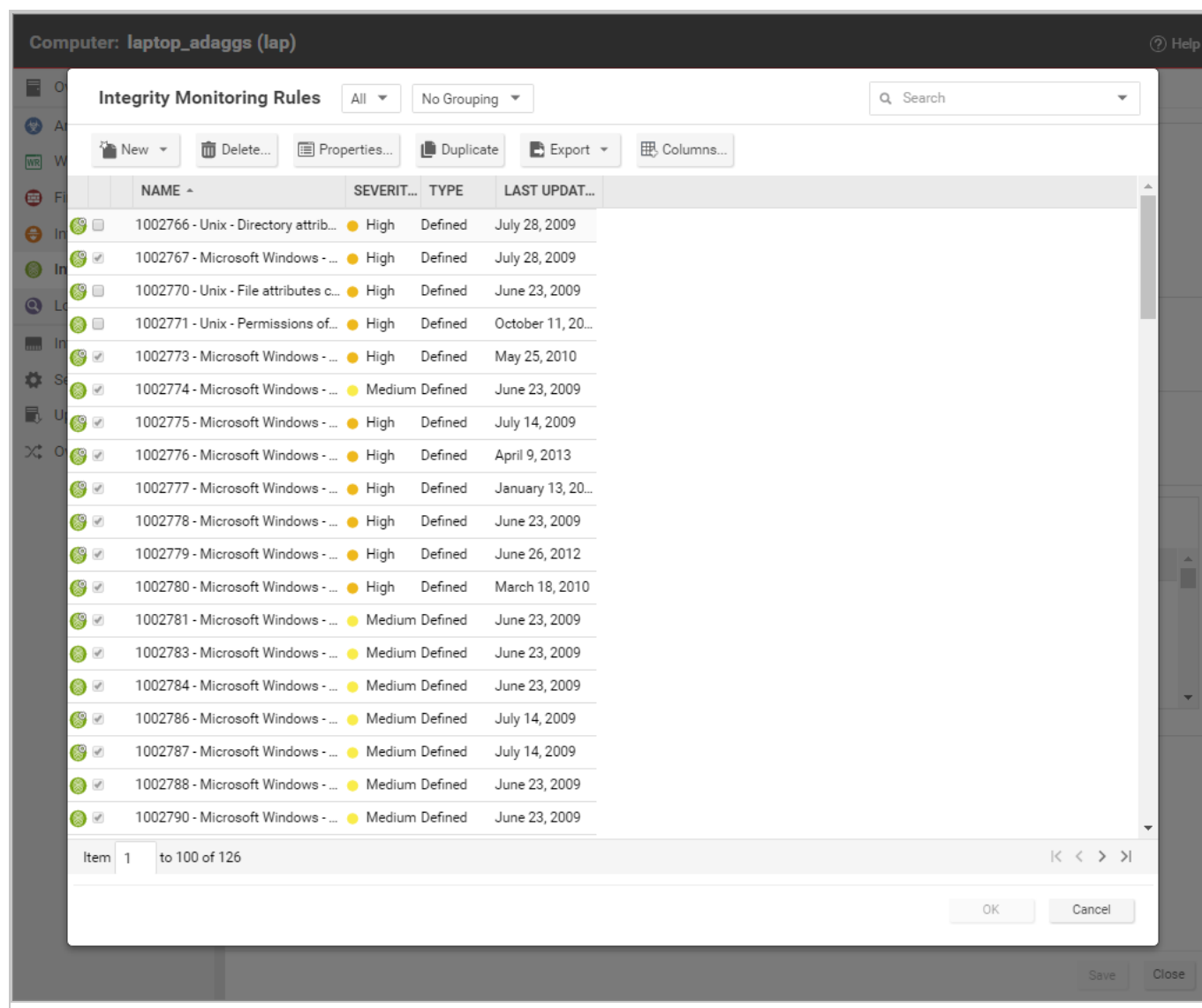

Some Integrity Monitoring rules written by Trend Micro require local configuration to function properly. If you assign one of these rules to your computers or one of these rules gets assigned automatically, an alert will be raised to notify you that configuration is required.

You can edit an Integrity Monitoring rule locally so that the changes apply only to the computer or policy being edited, or globally so that the changes apply to all other policies or computers that are using the rule. To edit a rule locally, right-click it and click **Properties**. To edit a rule globally, right-click it and click **Properties (Global)**.

You can also create custom rules to monitor for specific changes that concern your organization, such as a new user being added or new software being installed. For information on how to create a custom rule, see "[About the Integrity Monitoring rules language](#)" on page 989.

Tip: Integrity Monitoring rules should be as specific as possible to improve performance and to avoid conflicts and false positives. For example, do not create a rule that monitors the entire hard drive.

Build a baseline for the computer

The baseline is the original secure state that an Integrity Scan's results will be compared against. To create a new baseline for Integrity Scans on a computer, open the Computer editor, go to **Integrity Monitoring > General** and click **Rebuild Baseline**.

To view the current baseline data, click **View Baseline**.

Tip: It's a best practice to run a new baseline scan after applying patches.

Periodically scan for changes

Periodically scan for changes. To perform an on-demand scan, open the Computer editor, go to **Integrity Monitoring > General** and click **Scan for Integrity**. You can also create a [scheduled task](#) that performs scans on a regular basis.

Test Integrity Monitoring

Before continuing with further Integrity Monitoring configuration steps, test that the rules and baseline are working correctly:

1. Ensure Integrity Monitoring is enabled.
2. Go to the **Computer or Policy editor**¹ > **Integrity Monitoring > Assigned Integrity Monitoring Rules**. Click **Assign/Unassign**.
3. If you're a Windows user:
 - Search for **1002773 - Microsoft Windows - 'Hosts' file modified** and enable the rule. This rule raises an alert when changes are made to `C:\windows\system32\drivers\etc\hosts`.

If you're a Linux user

- Search for **1003513 - Unix - File attributes changes in /etc location** and enable the rule. This rule raises an alert when changes are made to the `/etc/hosts` file.

¹You can change these settings for a policy or for a specific computer. To change the settings for a policy, go to the **Policies** page and double-click the policy that you want to edit (or select the policy and click **Details**). To change the settings for a computer, go to the **Computers** page and double-click the computer that you want to edit (or select the computer and click **Details**).

4. Modify the above file and save the changes.
5. Go to **Computer editor**¹ > **Integrity Monitoring > General** and click **Scan for Integrity**.
6. Go to **Events & Reports > Integrity Monitoring Events** to verify the record of the modified host file. If the detection is recorded, the Integrity Monitoring module is working correctly.

When Integrity Monitoring scans are performed

There are three options for performing Integrity Monitoring scans:

- **On-demand scans:** You can initiate an on-demand integrity monitoring scan as needed by opening the **Computer editor**², and going to **Integrity Monitoring > General**. In the Integrity Scan section, click **Scan for Integrity**.
- **Scheduled scans:** You can schedule integrity monitoring scans just like other Deep Security operations. Deep Security checks the entities that are being monitored and identifies and records an event for any changes since the last time it performed a scan. Multiple changes to monitored entities between scans will not be tracked; only the last change will be detected. To detect and report multiple changes to an entity's state, consider increasing the frequency of scheduled scans (for example, daily instead of weekly) or enable real-time scanning for entities that change frequently. To enable scheduled integrity monitoring scans, go to **Administration > Scheduled Tasks > New**. In the New Scheduled Task Wizard, select **Scan Computers for Integrity Changes** and the frequency for the scheduled scan. Fill in the information requested by the New Scheduled Task Wizard with your desired specifications. For more information on scheduled tasks, see "[Schedule Deep Security to perform tasks](#)" on page 1766.
- **Real-time scans:** You can enable real-time scanning. When this option is selected, Deep Security monitors entities for changes in real time and raises integrity monitoring events when it detects changes. Events are forwarded in real time via syslog to the SIEM or when the next heartbeat communication to the Deep Security Manager occurs. To enable real-time scans, go to the **Computer or Policy Editor**³ > **Integrity Monitoring > General** and select **Real Time**. With Deep Security Agent 11.0 or higher on 64-bit Linux platforms and with Deep Security Agent 11.2 or higher on 64-bit Windows servers, the real-time scan

¹To open the Computer editor, go to the Computers page and double-click the computer that you want to edit (or select the computer and click Details).

²To open the Computer editor, go to the Computers page and double-click the computer that you want to edit (or select the computer and click Details).

³You can change these settings for a policy or for a specific computer. To change the settings for a policy, go to the Policies page and double-click the policy that you want to edit (or select the policy and click Details). To change the settings for a computer, go to the Computers page and double-click the computer that you want to edit (or select the computer and click Details).

results indicate the user and process that changed the file. For details about which platforms support this feature, see "[Supported features by platform](#)" on page 360.

Note: Real-time monitoring of an entire disk for changes to any file would affect performance and result in too many integrity monitoring events. As a safeguard, if you choose to monitor the root drive (C:\) in real time, Deep Security will only monitor executable files and scripts. If you want to perform real-time monitoring of all files, specify a folder other than the root drive.

Integrity Monitoring scan performance settings

Changing the following settings may help to improve the performance of Integrity Monitoring scans:

Limit CPU usage

Integrity Monitoring uses local CPU resources during the system scan that leads to the creation of the initial baseline and during the system scan that compares a later state of the system to the previously created baseline. If you are finding that Integrity Monitoring is consuming more resources than you want it to, you can restrict the CPU usage to the following levels:

- **High:** Scans files one after another without pausing
- **Medium:** Pauses between scanning files to conserve CPU resources
- **Low:** Pauses between scanning files for a longer interval than the medium setting

To change the **Integrity Monitoring CPU Usage Level** setting, open the **Computer or Policy editor**¹ and go to **Integrity Monitoring > Advanced**.

Change the content hash algorithm

You can select the hash algorithm(s) that will be used by the Integrity Monitoring module to store baseline information. You can select more than one algorithm, but this is not recommended because of the detrimental effect on performance.

You can change the content hash algorithm

¹You can change these settings for a policy or for a specific computer. To change the settings for a policy, go to the Policies page and double-click the policy that you want to edit (or select the policy and click Details). To change the settings for a computer, go to the Computers page and double-click the computer that you want to edit (or select the computer and click Details).

Enable a VM Scan Cache configuration

Using scan caching for Integrity Monitoring improves the efficiency of scans by eliminating the unnecessary scanning of identical content across multiple VMs in large VMware deployments. To select which scan cache configuration is used by a virtual machine, open the **Computer or Policy editor**¹ and go to **Integrity Monitoring > Advanced > VM Scan Cache**.

For information on Integrity Monitoring scan cache configurations, see "[Virtual Appliance Scan Caching](#)" on page 1035.

Integrity Monitoring event tagging

The events generated by the Integrity Monitoring module are displayed in Deep Security Manager, under **Events & Reports > Integrity Monitoring Events**. Event tagging can help you to sort events and determine which ones are legitimate and which ones need to be investigated further.

You can manually apply tags to events by right-clicking the event and then clicking **Add Tag(s)**. You can choose to apply the tag to only the selected event or to any similar Integrity Monitoring events.

You can also use the auto-tagging feature to group and label multiple events. To configure this feature in the Deep Security Manager, go to **Events and Reports > Integrity Monitoring Events > Auto-Tagging > New Trusted Source**. There are three sources that you can use to perform the tagging:

- A Local Trusted Computer.
- The Trend Micro Certified Safe Software Service.
- A Trusted Common Baseline, which is a set of file states collected from a group of computers.

For more information on event tagging, see "[Apply tags to identify and group events](#)" on page 1136.

¹You can change these settings for a policy or for a specific computer. To change the settings for a policy, go to the Policies page and double-click the policy that you want to edit (or select the policy and click Details). To change the settings for a computer, go to the Computers page and double-click the computer that you want to edit (or select the computer and click Details).

Create an Integrity Monitoring rule

Integrity Monitoring rules describe how Deep Security Agents should scan for and detect changes to a computer's files, directories, and registry keys and values, as well as changes in installed software, processes, listening ports, and running services. Integrity Monitoring rules can be assigned directly to computers or can be made part of a policy.

Note: This article specifically covers how to create an Integrity Monitoring rule. For information on how to configure the Integrity Monitoring module, see ["Set up Integrity Monitoring" on page 977](#).

There are two types of Integrity Monitoring rules: those that you have created, and those that are issued by Trend Micro. For more information on how to configure rules issued by Trend Micro, see the ["Configure Trend Micro Integrity Monitoring rules" on page 987](#) section.

To create a new Integrity Monitoring rule, you need to:

1. ["Add a new rule" below](#).
2. ["Enter Integrity Monitoring rule information " on the next page](#).
3. ["Select a rule template and define rule attributes" on the next page](#).

When you're done with your rule, you can also learn how to

- ["Configure rule events and alerts" on page 988](#)
- ["See policies and computers a rule is assigned to" on page 989](#)
- ["Export a rule" on page 989](#)
- ["Delete a rule" on page 989](#)

Add a new rule

There are three ways to add an Integrity Monitoring rule on the **Policies > Common Objects > Rules > Integrity Monitoring Rules** page. You can:

- Create a new rule. Click **New > New Integrity Monitoring Rule**.
- Import a rule from an XML file. Click **New > Import From File**.
- Copy and then modify an existing rule. Right-click the rule in the Integrity Monitoring Rules list and then click **Duplicate**. To edit the new rule, select it and then click **Properties**.

Enter Integrity Monitoring rule information

1. Enter a **Name** and **Description** for the rule.

Tip: It is good practice to document all Integrity Monitoring rule changes in the Description field of the rule. Make a note of when and why rules were created or deleted for easier maintenance.

2. Set the **Severity** of the rule.

Note: Setting the severity of a rule has no effect on how the rule is implemented or applied. Severity levels can be useful as sorting criteria when viewing a list of Integrity Monitoring rules. More importantly, each severity level is associated with a severity value; this value is multiplied by a computer's Asset Value to determine the ranking of an event. (See **Administration > System Settings > Ranking**.)

Select a rule template and define rule attributes

Go to the **Content** tab and select from one of the following three templates:

Registry Value template

Create an Integrity Monitoring rule to specifically monitor changes to registry values.

Note: The Registry Value template is only for Windows-based computers .

1. Select the **Base Key** to monitor and whether or not to monitor contents of sub keys.
2. List **Value Names** to be included or excluded. You can use "?" and "*" as wildcard characters.
3. Enter **Attributes** to monitor. Entering "STANDARD" will monitor changes in registry size, content and type. For more information on Registry Value template attributes see the "[RegistryValueSet](#)" on page 1021 documentation.

File template

Create an Integrity Monitoring rule to specifically monitor changes to files.

1. Enter a **Base Directory** for the rule (for example, `C:\Program Files\MySQL\.`) Select **Include Sub Directories** to include the contents of all subdirectories relative to the base directory. Wildcards are not supported for base directories.

2. Use the **File Names** fields to include or exclude specific files. You can use wildcards (" ? " for a single character and " * " for zero or more characters.

Note: Leaving the **File Names** fields blank will cause the rule to monitor all files in the base directory. This can use significant system resources if the base directory contains numerous or large files.

3. Enter **Attributes** to monitor. Entering "STANDARD" will monitor changes in file creation date, last modified date, permissions, owner, group, size, content, flags (Windows), and SymLinkPath (Linux). For more information on File template attributes see the "[FileSet](#)" on [page 1005](#) documentation.

Custom (XML) template

Create a custom Integrity Monitoring rule template to monitor [directories](#), [registry values](#), [registry keys](#), [services](#), [processes](#), [installed software](#), [ports](#), [groups](#), [users](#), [files](#), and the [WQL](#) using the Deep Security XML-based "[About the Integrity Monitoring rules language](#)" on [page 989](#).





Tip: You can create your rule in your preferred text editor and paste it to the **Content** field when you are done.

Configure Trend Micro Integrity Monitoring rules

Integrity Monitoring rules issued by Trend Micro cannot be edited in the same way as the custom rules you create. Some Trend Micro rules cannot be modified at all, while other rules may offer limited configuration options. Both of these rule types will show as "Defined" under the "Type" column, but rules that can be configured will display a gear in the Integrity Monitoring icon (.

Integrity Monitoring Rules No Grouping ▾ 🔍 Search this page

New ▾
Delete...
Properties...
Duplicate
Export ▾

NAME	SEVERITY	TYPE	LAST UPDATED ▲
 New Integrity Monitoring Rule	● Medium	Custom	N/A
 1002784 - Microsoft Windows - IE A...	● Medium	Defined	June 23, 2009
 1002781 - Microsoft Windows - Attri...	● Medium	Defined	June 23, 2009
 1002778 - Microsoft Windows - Syst...	● High	Defined	June 23, 2009

You can access the configuration options for a rule by opening the properties for the rule and clicking on the **Configuration** tab.

Rules issued by Trend Micro also show the following additional information under the **General** tab:

- When the rule was first issued and last updated, as well as a unique identifier for the rule.
- The minimum versions of the Agent and the Deep Security Manager that are required for the rule to function.

Although you cannot edit rules issued by Trend Micro directly, you can duplicate them and then edit the copy.

Configure rule events and alerts

Any changes detected by an Integrity Monitoring rule is logged as an event in the Deep Security Manager.

Real-time event monitoring

By default, events are logged at the time they occur. If you only want events to be logged when you manually perform a scan for changes, deselect **Allow Real Time Monitoring**.

Alerts

You can also configure the rules to trigger an alert when they log an event. To do so, open the properties for a rule, click on **Options**, and then select **Alert when this rule logs an event**.

See policies and computers a rule is assigned to

You can see which policies and computers are assigned to an Integrity Monitoring rule on the **Assigned To** tab. Click on a policy or computer in the list to see their properties.

Export a rule

You can export all Integrity Monitoring rules to a .csv or .xml file by clicking **Export** and selecting the corresponding export action from the list. You can also export specific rules by first selecting them, clicking **Export** and then selecting the corresponding export action from the list.

Delete a rule

To delete a rule, right-click the rule in the Integrity Monitoring Rules list, click **Delete** and then click **OK**.

Note: Integrity Monitoring rules that are assigned to one or more computers or that are part of a policy cannot be deleted.

Integrity Monitoring rules language

About the Integrity Monitoring rules language

The Integrity Monitoring rules language is a declarative XML-based language that describes the system components and associated attributes that should be monitored by Deep Security. It also provides a means to specify what components within a larger set of components should be excluded from monitoring.

Tip: If you only need to monitor for unauthorized changes to files or the Windows registry, you can use File and Registry rule templates instead of creating a custom one. For more information on using these templates, see ["Create an Integrity Monitoring rule" on page 985](#).

To create a new custom Integrity Monitoring rule, start with the procedure in ["Create an Integrity Monitoring rule" on page 985](#) (selecting **Custom (XML)** as the template type), then create your custom rule according to the Integrity Monitoring rules language, as covered in the following sections:

- ["Entity Sets" below](#)
- ["Hierarchies and wildcards" on the next page](#)
- ["Syntax and concepts" on page 992](#)
- ["Include tag" on page 993](#)
- ["Exclude tag" on page 994](#)
- ["Case sensitivity" on page 994](#)
- ["Entity features" on page 995](#)
- ["ANDs and ORs" on page 996](#)
- ["Order of evaluation" on page 997](#)
- ["Entity attributes" on page 997](#)
- ["Shorthand attributes" on page 999](#)
- ["onChange attribute" on page 999](#)
- ["Environment variables" on page 999](#)
- ["Registry values" on page 1001](#)
- ["Use of ".." on page 1001](#)
- ["Best practices" on page 1002](#)

Entity Sets

System components included in an Integrity Monitoring rule are referred to as "Entities". Each type of component is a class of Entity. For example, files, registry keys, and processes are each a class of Entity. The Integrity Monitoring Rules language provides a tag for describing a set of Entities (an Entity Set) for each class of Entity. The following **Entity Set** types are available to be used in a rule:

- ["DirectorySet" on page 1002](#): rules will scan the integrity of directories
- ["FileSet" on page 1005](#): rules will scan the integrity of files
- ["GroupSet" on page 1010](#): rules will scan the integrity of groups
- ["InstalledSoftwareSet" on page 1011](#): rules will scan the integrity of installed software
- ["PortSet" on page 1013](#): rules will scan the integrity of listening ports
- ["ProcessSet" on page 1017](#): rules will scan the integrity of processes
- ["RegistryKeySet" on page 1020](#): rules will scan registry keys
- ["RegistryValueSet" on page 1021](#): rules will scan registry values
- ["ServiceSet" on page 1024](#): rules will scan the integrity of services

- "UserSet" on page 1026: rules will scan the integrity of users
- "WQLSet" on page 1030: rules will monitor the integrity of the results of a [Windows Management Instrumentation](#) WQL query statement

A single Integrity Rule can contain multiple Entity Sets. This allows you to, for example, secure an application with a single rule that monitors multiple files and registry entries.

Hierarchies and wildcards

For Entity Sets that represent a hierarchical data type such as FileSet and RegistryKeySet, section-based pattern matching is supported:

- `/` (forward slash) : demarcates sections of the pattern to be applied to levels of the hierarchy
- `**` (two stars) : matches zero or more sections

The following wildcards are supported:

- `?` (question mark) : matches one character
- `*` (one star) : matches zero or more characters

"Escaping" characters is also supported:

- `\` (back slash) : escapes the next character

The pattern is divided into sections using the "`/`" character, with each section of the pattern being applied to successive levels of the hierarchy as long as it continues to match. For example, if the pattern:

```
/a?c/123/*.java
```

is applied to the path:

```
/abc/123/test.java
```

Then:

- `"a?c"` matches "abc"
- `"123"` matches "123"
- `"*.java"` matches "test.java"

When the pattern is applied to the path:

```
/abc/123456/test.java
```

Then:

- "a?c " matches "abc"
- " 123 " does *not* match "123456", and so no more matching is performed

The " ** " notation pattern matches zero or more sections, and so:

```
/abc/**/*.java
```

matches both "abc/123/test.java" and "abc/123456/test.java". It would also match "abc/test.java" and "abc/123/456/test.java".

Syntax and concepts

This section will present some example Integrity Monitoring rules. The examples will use the **FileSet** Entity Set but the topics and components described are common to all Entity Sets. A minimal Integrity Monitoring rule could look like this:

```
<FileSet base="C:\Program Files\MySQL">  
</FileSet>
```

The "base" attribute specifies the base directory for the FileSet. Everything else about the rule will be relative to this directory. If nothing further is added to the rule, everything (including subdirectories) below the "base" will be monitored for changes.

Note: The " * " and " ? " wildcards can be used in a "base" attribute string, but only in the last path component of the base. So this is valid:

```
base="C:\program files\CompanyName * Web Server"
```

but this is not:

```
base="C:\* files\Microsoft Office"
```

Within an Entity Set, "include" and "exclude" tags can be used to control pattern matching. These tags have a "key" attribute that specifies the pattern to match against. The source of the key varies by Entity Set. For example, for Files and Directories it is their path, while for Ports it is the unique protocol/IP/portNumber tuple.

Note: If a path supplied in an include or exclude rule is syntactically invalid, the Agent will generate an "Integrity Monitoring Rule Compile Issue" Agent Event and supply the rule ID and the path (after expansion) as parameters. An example of an invalid path would be `C:\test1\D:\test2` since a file name may not contain two volume identifiers.

Include tag

The include tag is essentially an allow list. Using it means that only those Entities matched by it (or other include tags) will be included. By adding an include tag, the following rule now only monitors changes to files with the name "*.exe" in the "C:\Program Files\MySQL" folder and sub folders:

```
<FileSet base="C:\Program Files\MySQL">
  <include key="**/*.exe"/>
</FileSet>
```

"Includes" can be combined. The following rule will monitor changes to files with the names "*.exe" and "*.dll" in the "C:\Program Files\MySQL" folder and sub folders:

```
<FileSet base="C:\Program Files\MySQL">
  <include key="**/*.exe"/>
  <include key="**/*.dll"/>
</FileSet>
```

It is also possible to combine multiple criteria in a single include block, in which case **all** criteria must be true for a given Entity to be included. The following "include" tag requires that an Entity both end in ".exe" and start with "sample" to be included. Although this requirement could be represented more succinctly, the usefulness of this becomes more apparent as key patterns are combined with other features of the Entity, as described in the "Features" section below.

```
<include>
  <key pattern="**/*.exe"/>
  <key pattern="**/sample*"/>
</include>
```

The following is another way to express the same requirements:

```
<include key="**/*.exe">
  <key pattern="**/sample*"/>
</include>
```

Exclude tag

The exclude tag functions as a block list, removing files from the set that would otherwise be returned. The following (unlikely) example would place everything but temp files under watch.

```
<FileSet base="C:\Program Files\MySQL">
  <include key="**"/>
  <exclude key="**/*.tmp"/>
</FileSet>
```

The following rule excludes the "MySQLInstanceConfig.exe" from the set of EXEs and DLLs:

```
<FileSet base="C:\Program Files\MySQL">
  <include key="**/*.exe"/>
  <include key="**/*.dll" />
  <exclude key="**/MySQLInstanceConfig.exe"/>
</FileSet>
```

Like the "include" tag, the "exclude" tag can be written to require multiple criteria. The following example shows a multi-criteria "exclude" tag.

```
<exclude>
  <key pattern="**/MySQLInstanceConfig*" />
  <key pattern="**/*.exe" />
</exclude>
```

Case sensitivity

The case sensitivity of pattern matching for an include or exclude tag may be controlled by the "casesensitive" attribute. The attribute has three allowed values:

- **true**
- **false**
- **platform**

The default value for this attribute is "platform", which means that the case sensitivity of the pattern will match the platform on which it is running. In the following example, both "Sample.txt" and "sample.txt" would be returned on a Windows system, but only "Sample.txt" would be returned on a Unix system:

```
<FileSet base="C:\Program Files\MySQL">
  <include key="**/*Sample*" />
</FileSet>
```

In this example, only "Sample.txt" would be returned on Windows and Unix:

```
<FileSet base="C:\Program Files\MySQL">
  <include key="**/*Sample*" casesensitive="true"/>
</FileSet>
```

Note: A case sensitive setting of "true" is of limited use on a platform such as Windows which is case insensitive when it comes to most object names.

Entity features

The inclusion and exclusion of Entities based on features other than their "key" is also supported for some Entity types. The set of features differs by Entity type. The following example will include all executable files. It does not depend on the file extension as previous examples using file extensions did, but instead will check the first few hundred bytes of the file to determine if it is executable on the given OS.

```
<FileSet base="C:\Program Files\MySQL">
  <include key="**" executable="true"/>
</FileSet>
```

Feature attributes must appear in an "include" or "exclude" tag. To use them as part of a multi-criteria include or exclude, they must be specified as attributes of the enclosing include or exclude tag. The following example includes all files that contain the string "MySQL" in their name and are also executable:

```
<include executable="true">
  <key pattern="**/*MySQL*" />
</include>
```

The previous example can be more succinctly expressed as:

```
<include key="**/*MySQL*" executable="true"/>
```

Some feature attributes are simply matches against the value of one of the Entity's attributes. In such cases, wildcard matches using " * " and " ? " are sometimes supported. The help pages for the individual ["Entity Sets" on page 990](#) indicate which attributes can be used in include or exclude rules in this way, and whether they support wildcard matching or simple string matching.

Note: Where wildcard matches *are* supported, it is important to note that the match is against the string value of the attribute and that no normalization takes place. Constructs available for

Entity key matches such as "*" and the use of "/" to separate hierarchical components don't apply. Matching a path name on Windows requires the use of "\" since that is the character which appears in the value of the attribute being tested, whereas Unix systems will use "/" in path values so matches against Unix paths need to use "/".

The following is an example of a feature match using the "state" attribute:

```
<ServiceSet>
  <include state="running"/>
</ServiceSet>
```

Note: Wildcards are not supported in state matches.

The following example matches any processes where the path of the binary ends in "\notepad.exe":

```
<ProcessSet>
  <include path="*\notepad.exe"/>
</ProcessSet>
```

The following example matches any processes where the command-line begins with "/sbin/":

```
<ProcessSet>
  <include commandLine="/sbin/*"/>
</ProcessSet>
```

Note: Be careful when using wildcards. A wildcard expression like "*" will look at every file in every sub directory beneath "base". Creating a baseline for such an expression can take a lot of time and resources.

ANDs and ORs

It is possible to express logical ANDs and ORs through the use of multi-criteria includes and excludes and multiple includes and excludes.

There are several ways that a multi criteria include or exclude can be used to express an AND. The most straightforward is to include multiple criteria within a single enclosing tag. The following example shows a simple multi-criteria AND-ing:

```
<include>
  <key pattern="**/*MySQL*" />
```

```
<key pattern="**/*.exe"/>
</include>
```

As well, any criteria expressed as an attribute of the including tag will be grouped with the enclosed criteria as part of the multi-criteria requirement. The following example shows the previous multi-criteria "include" re-written in this way:

```
<include key="**/*.exe">
  <key pattern="**/*MySQL*" />
</include>
```

Finally, if multiple criteria are expressed as attributes of an include or exclude they are treated as an AND:

```
<include executable="true" key="**/*MySQL*" />
```

ORs are expressed simply by the inclusion of multiple include or exclude tags. The following code includes files if their extensions are ".exe" OR ".dll":

```
<include key="**/*.dll" />
<include key="**/*.exe" />
```

Order of evaluation

All "includes" are processed first, regardless of order of appearance in the rule. If an object name matches at least one "include" tag, it is then tested against the "exclude" tags. It is removed from the set of monitored objects if it matches at least one "exclude" tag.

Entity attributes

A given Entity has a set of attributes that can be monitored. If no attributes are specified for an Entity Set (i.e. the attributes wrapper tag is not present) then the STANDARD set of attributes for that Entity is assumed. (See the *Shorthand Attributes* sections for the individual ["Entity Sets" on page 990.](#))

However, for a given Entity Set only certain attributes of the Entity may be of interest for Integrity Monitoring. For example, changes to the contents of a log file are most likely expected and allowed. However changes to the permissions or ownership should be reported.

The "attributes" tag of the Entity Sets allows this to be expressed. The "attributes" tag contains a set of tags enumerating the attributes of interest. The set of allowed "attribute" tags varies depending on the Entity Set for which they are being supplied.

Note: If the "attributes" tag is present, but contains no entries, then the Entities defined by the rule are monitored for existence only.

The following example monitors executable files in "C:\Program Files\MySQL" whose name includes "SQL" for changes to their "last modified", "permissions", and "owner" attributes:

```
<FileSet base="C:\Program Files\MySQL" >
  <include key="**/*SQL*" executable="true"/>
  <attributes>
    <lastModified/>
    <permissions/>
    <owner/>
  </attributes>
</FileSet>
```

The following example monitors the "permissions", and "owner" attributes of log files in "C:\Program Files\MySQL":

```
<FileSet base="C:\Program Files\MySQL" >
  <attributes>
    <permissions/>
    <owner/>
  </attributes>
  <include key="**/*.log" />
</FileSet>
```

In the following example, the STANDARD set of attributes will be monitored. (See Shorthand Attributes, below)

```
<FileSet base="C:\Program Files\MySQL" >
  <include key="**/*.log" />
</FileSet>
```

In the following example, no attributes will be monitored. Only the existence of the Entities will be tracked for change.

```
<FileSet base="C:\Program Files\MySQL" >
  <attributes/>
  <include key="**/*.log" />
</FileSet>
```

Shorthand attributes

Shorthand attributes provide a way to specify a group of attributes using a single higher level attribute. Like regular attributes the set of allowed values differs based on the Entity Set for which they are being supplied.

Shorthand Attributes are useful in cases where a set of attributes naturally group together, in cases where exhaustively listing the set of attributes would be tedious, and in cases where the set of attributes represented by the high level attribute may change with time or system configuration. An example of each case follows:

Attribute	Description
STANDARD	The set of attributes to monitor for the Entity Set. This is different than "every possible attribute" for the Entity Set. For example, it would not include every possible hash algorithm, just the ones deemed sufficient. For the list of "standard" attributes for each Entity Set, see sections for the individual "Entity Sets" on page 990 .
CONTENTS	This is Shorthand for the hash, or set of hashes, of the contents of the file. Defaults to SHA-1.

onChange attribute

An EntitySet may be set to monitor changes in real time. If the onChange attribute of an EntitySet is set to true (the default value) then the entities returned by the EntitySet will be monitored for changes in real time. When a change is detected the Entity is immediately compared against its baseline for variation. If the onChange attribute of an EntitySet is set to false, it will be run only when a baseline is built or when it is triggered via a scheduled task or on demand by the Deep Security Manager.

The following sample monitors the MySQL binaries in real time:

```
<FileSet base="C:\Program Files\MySQL" onChange="true">
  <include key="**/*.exe"/>
  <include key="**/*.dll" />
</FileSet>
```

Environment variables

Environment variables can be included in the base value used in Entity Sets. They are enclosed in "\${}". The variable name itself is prefaced with "env.".

The following example sets the base directory of the FileSet to the path stored in the PROGRAMFILES environment variable:

```
<FileSet base="{env.PROGRAMFILES}"/>
```

Note: The values of referenced environment variables are read and stored by the Deep Security Agent on Agent startup. If the value of an environment variable changes, the Agent must be restarted to register the change.

If a referenced environment variable is not found, the Entity Sets referencing it are not scanned or monitored, but the rest of the configuration is used. An alert is triggered indicating that the variable is not present. The Agent reports an invalid environment variable using Agent event "Integrity Monitoring Rule Compile Issue". The ID of the Integrity Monitoring rule and the environment variable name are supplied as parameters to the event.

The following are the default environment variables that Integrity Monitoring uses:

Name	Value
ALLUSERSPROFILE	C:\ProgramData
COMMONPROGRAMFILES	C:\Program Files\Common Files
PROGRAMFILES	C:\Program Files
SYSTEMDRIVE	C:
SYSTEMROOT	C:\Windows
WINDIR	C:\Windows

Environment variable overrides

Override environment variables when non-standard locations are used in the Windows operating system. For example, the **Microsoft Windows - 'Hosts' file modified** Integrity Monitoring rule, which monitors changes to the Windows `hosts` file, looks for that file in the `C:\WINDOWS\system32\drivers\etc` folder. However not all Windows installations use the `C:\WINDOWS\` directory, so the Integrity Monitoring rule uses the `WINDIR` environment variable and represents the directory as `%WINDIR%\system32\drivers\etc`.

Note: Environment variables are used primarily by the virtual appliance when performing agentless Integrity Monitoring on a virtual machine. This is because the virtual appliance has no way of knowing if the operating system on a particular virtual machine is using standard directory locations.

1. Open the **Computer or Policy editor**¹ where you want to override an environment variable.
2. Click **Settings > Advanced**.
3. In the **Environment Variable Overrides** section, click **View Environment Variables** to display the **Environment Variable Overrides** page.
4. Click **New** in the menu bar and enter a new name-value pair (for example, `WINDIR` and `D:\Windows`) and click **OK**.

Registry values

Registry values can be included in the base value used in Entity Sets. They are enclosed in `{}`. The path to the registry value itself is prefaced with "reg.". The following example sets the base directory of the FileSet to the path stored in the "HKLM\Software\Trend Micro\Deep Security Agent\InstallationFolder" registry value:

```
<FileSet base="{reg.HKLM\Software\Trend Micro\Deep Security Agent\InstallationFolder}"/>
```

The values of referenced registry values are read when a new or changed rule is received by the Agent. The Agent also checks all rules at startup time and will rebuild the baseline for affected Rules if any referenced registry values change.

If a referenced registry value is not found, the EntitySets referencing it are not scanned or monitored, but the rest of the configuration is used. An alert notifying that the variable is not present is raised. The Agent reports an invalid environment variable expansion using Agent Event 8012. The ID of the Integrity Monitoring rule and the registry value path are supplied as parameters to the event.

Note: A wildcard is allowed only in the last hierarchical component of a base name. For example, `base="HKLM\Software\ATI*"` is valid and will find both "HKLM\Software\ATI" and "HKLM\Software\ATI Technologies"; however, `base="HKLM*\Software\ATI*"` is invalid.

Use of ".."

The ".." convention for referencing a parent directory is supported in all current versions of the Agent. The Agent will attempt to normalize base directory names for FileSet and DirectorySet elements by resolving ".." references and converting Windows short names to long names. For example, on some newer versions of Windows the following FileSet would have a base

¹You can change these settings for a policy or for a specific computer. To change the settings for a policy, go to the Policies page and double-click the policy that you want to edit (or select the policy and click Details). To change the settings for a computer, go to the Computers page and double-click the computer that you want to edit (or select the computer and click Details).

directory of `C:\Users`. On earlier versions of Windows it would be `C:\Documents and Settings`.

```
<FileSet base="{env.USERPROFILE}\..">
  <include key="*/Start Menu/Programs/Startup/*"/>
</FileSet>
```

Best practices

Rules should be written to only include objects and attributes that are of significance. This will ensure that no events are reported if other attributes of the object change. For example, your change monitoring policy may place restrictions on permission and ownership of files in `/bin`. Your Integrity Monitoring rule should monitor owner, group, and permissions, but not other attributes like lastModified or hash values.

When using Integrity Monitoring rules to detect malware and suspicious activity, monitor services, watch for use of NTFS data streams, and watch for executable files in unusual places such as `" /tmp "` or `" ${env.windir}\temp "`.

Always be as specific as possible when specifying what objects to include in a rule. The fewer objects you include, the less time it will take to create your baseline and the less time it will take to scan for changes. Exclude objects which are expected to change and only monitor the attributes you are concerned about.

When creating a rule, do not:

- Use `" **/... "` from a top-level of the hierarchy such as `" / "`, `"C:\"`, or `" HKLM\Software "`.
- Use more than one content hash type unless absolutely necessary.
- Reference user-specific locations such as `HKEY_CURRENT_USER`, `{env.USERPROFILE}`, or `{env.HOME}`.

Any of these statements in your integrity monitoring rules will cause performance issues as the Deep Security Agent searches through many items in order to match the specified patterns.

DirectorySet

Note: The Integrity Monitoring module scans for unexpected changes to [directories](#), [registry values](#), [registry keys](#), [services](#), [processes](#), [installed software](#), [ports](#), [groups](#), [users](#), [files](#), and the [WQL](#) query statement on Deep Security Agents. To enable and configure Integrity Monitoring, see ["Set up Integrity Monitoring" on page 977](#).

The DirectorySet tag describes a set of Directories.

Tag Attributes

These are XML attributes of the tag itself, as opposed to the attributes of the Entity monitored by Integrity Monitoring Rules.

Attribute	Description	Required	Default Value	Allowed Values
base	Sets the base directory of the DirectorySet. Everything else in the tag is relative to this directory	Yes	N/A	String values resolving to syntactically valid path (Path is not required to exist) Note: UNC paths are allowed by Windows Agents, but require that the remote system allow access by the "LocalSystem" account of the Agent computer. The Agent is a Windows service and runs as LocalSystem, aka NT AUTHORITY\SYSTEM. When accessing a network resource, the LocalSystem uses the computer's credentials, which is an account named <i>DOMAINMACHINE\$</i> . The access token presented to the remote computer also contains the "Administrators" group for the computer, so remote shares must grant read privileges to either the Agent computer's account, the Agent computer's Administrators group, or "Everyone". For testing access to UNC paths, launch a Windows command prompt running as a service under the LocalSystem account. With that, you can try accessing network and local resources, or launch other applications that will run under the LocalSystem account. If the base value is not syntactically valid, the FileSet will not be processed. The rest of the config will be evaluated.
onChange	Whether the directories returned should be monitored in real time.	No	false	true, false
followLinks	Will this DirectorySet follow symbolic links.	No	false	true, false

Entity Set Attributes

These are the attributes of the Entity that may be monitored by Integrity Monitoring Rules.

- **Created:** Timestamp when the directory was created
- **LastModified:** Timestamp when the directory was last modified
- **LastAccessed:** Timestamp when the directory was last accessed. On Windows this value does not get updated immediately, and recording of the last accessed timestamp can be disabled as a performance enhancement. See [File Times](#) for details. The other problem with this attribute is that the act of scanning a directory requires that the Agent open the directory, which will change its last accessed timestamp.
- **Permissions:** The directory's security descriptor (in [SDDL](#) format) on Windows or Posix-style ACLs on Unix systems that support ACLs, otherwise the Unix style rwxrwxrwx file permissions in numeric (octal) format.
- **Owner:** User ID of the directory owner (commonly referred to as the "UID" on Unix)
- **Group:** Group ID of the directory owner (commonly referred to as the "GID" on Unix)
- **Flags:** Windows-only. Flags returned by the [GetFileAttributes\(\)](#) Win32 API. Windows Explorer calls these the "Attributes" of the file: Read-only, Archived, Compressed, etc.
- **SymLinkPath:** If the directory is a symbolic link, the path of the link is stored here. On Windows, use the SysInternals "junction" utility to create the Windows equivalent of symbolic links.
- **InodeNumber** (Unix and Linux only): Inode number of the disk on which the inode associated with the file is stored
- **DeviceNumber** (Unix and Linux only): Device number of the disk on which the inode associated with the directory is stored

Short Hand Attributes

The following are the Short Hand Attributes, and the attributes to which they map.

- **STANDARD:**
 - Created
 - LastModified
 - Permissions
 - Owner
 - Group
 - Flags (Windows only)
 - SymLinkPath

Meaning of "Key"

Key is a pattern to match against the path of the directory relative to the directory specified by "dir". This is a hierarchical pattern, with sections of the pattern separated by "/" matched against sections of the path separated by the file separator of the given OS.

Sub Elements

- Include
- Exclude

See ["About the Integrity Monitoring rules language" on page 989](#) for a general description of Include and Exclude for their allowed attributes and sub elements. Only information specific to includes and excludes relating to this EntitySet class are included here.

FileSet

Note: The Integrity Monitoring module scans for unexpected changes to [directories](#), [registry values](#), [registry keys](#), [services](#), [processes](#), [installed software](#), [ports](#), [groups](#), [users](#), [files](#), and the [WQL](#) query statement on Deep Security Agents. To enable and configure Integrity Monitoring, see ["Set up Integrity Monitoring" on page 977](#).

The FileSet tag describes a set of Files.

Tag Attributes

These are XML attributes of the tag itself, as opposed to the attributes of the Entity monitored by Integrity Monitoring Rules.

Attribute	Description	Required	Default Value	Allowed Values
base	Sets the base directory of the FileSet. Everything else in the tag is relative to this directory.	Yes	N/A	String values resolving to syntactically valid path (Path is not required to exist). Note: UNC paths are allowed by Windows Agents, but require that the remote system allow access by the "LocalSystem" account of the Agent computer. The Agent is a Windows service and runs as LocalSystem, aka NT AUTHORITY\SYSTEM. When accessing a network resource, the LocalSystem uses the computer's credentials, which is an account named <i>DOMAINMACHINE\$</i> . The access token presented to the remote computer also contains the "Administrators" group for the computer, so remote

Attribute	Description	Required	Default Value	Allowed Values
				shares must grant read privileges to either the Agent computer's account, the Agent computer's Administrators group, or "Everyone". For testing access to UNC paths, launch a Windows command prompt running as a service under the LocalSystem account. With that, you can try accessing network and local resources, or launch other applications that will run under the LocalSystem account. If the base value is not syntactically valid, the FileSet will not be processed. The rest of the config will be evaluated.
onChange	Whether the files returned should be monitored in real time.	No	false	true, false
followLinks	Will this FileSet follow symbolic links.	No	false	true, false

Entity Set Attributes

These are the attributes of the FileSet that can be monitored by Integrity Monitoring Rules.

Note: For Created, LastModified, and LastAccessed in a Linux environment, the Real-time Integrity Monitoring module detects scans where the file contents have changed, but does not detect a change such as touching a file, reading a file, or any other change that updates only metadata such as the time a file was altered.

- **Created:** Timestamp when the file was created
- **LastModified:** Timestamp when the file was last modified
- **LastAccessed:** Timestamp when the file was last accessed. On Windows this value does not get updated immediately, and recording of the last accessed timestamp can be disabled as a performance enhancement. See [File Times](#) for details. The other problem with this attribute is that the act of scanning a file requires that the Agent open the file, which will change its last accessed timestamp. On Unix, the Agent will use the O_

NOATIME flag if it is available when opening the file, which prevents the OS from updating the last accessed timestamp and speeds up scanning.

- **Permissions:** The file's security descriptor (in [SDDL](#) format) on Windows or Posix-style ACLs on Unix systems that support ACLs, otherwise the Unix style rwxrwxrwx file permissions in numeric (octal) format.
- **Owner:** User ID of the file owner (commonly referred to as the "UID" on Unix)
- **Group:** Group ID of the file owner (commonly referred to as the "GID" on Unix)
- **Size:** size of the file
- **Sha1:** SHA-1 hash
- **Sha256:**SHA-256 hash
- **Md5:** MD5 hash (deprecated)
- **Flags:** Windows-only. Flags returned by the [GetFileAttributes\(\)](#) Win32 API. Windows Explorer calls these the "Attributes" of the file: Read-only, Archived, Compressed, etc.
- **SymLinkPath** (Unix and Linux only): If the file is a symbolic link, the path of the link is stored here. Windows NTFS supports Unix-like symlinks, but only for directories, not files. Windows shortcut objects are not true symlinks since they are not handled by the OS; the Windows Explorer handles shortcut files (*.lnk) but other applications that open a *.lnk file will see the contents of the lnk file.
- **InodeNumber** (Unix and Linux only): Inode number of the disk on which the inode associated with the file is stored
- **DeviceNumber** (Unix and Linux only): Device number of the disk on which the inode associated with the file is stored
- **BlocksAllocated** (Linux and Unix only): The number of blocks allocated to store the file.
- **Growing:** If the size of the file stays the same or increases between scans the value is "true", otherwise "false". This is mainly useful for log files that have data appended to them. Note that rolling over a log file will trigger a change in this attribute.
- **Shrinking:** If the size of the file stays the same or decreases between scans the value is "true", otherwise "false".

Short Hand Attributes

The following are the Short Hand Attributes, and the attributes to which they map.

- **CONTENTS:** Resolves to the content hash algorithm set in **Computer or Policy editor**¹ > **Integrity Monitoring > Advanced**.
- **STANDARD:** Created, LastModified, Permissions, Owner, Group, Size, Contents, Flags (Windows only), SymLinkPath (Unix only)

Drives Mounted as Directories

Drives mounted as directories are treated as any other directory, unless they are a network drive in which case they are ignored.

Alternate Data Streams

NTFS based file systems support the concept of alternate data streams. When this feature is used it behaves conceptually like files within the file.

Note: To demonstrate this, type the following at the command prompt:

```
echo plain > sample.txt
echo alternate > sample.txt:s
more < sample.txt
more < sample.txt:s
```

The first "more" will show only the text "plain", the same text that will be displayed if the file is opened with a standard text editor, such as notepad. The second "more", which accesses the "s" stream of sample.txt will display the string "alternate".

For FileSets, if no stream is specified, then all streams are included. Each stream is a separate Entity entry in the baseline. The available attributes for streams are:

- **size**
- **Sha1**
- **Sha256**
- **Md5** (deprecated)
- **Contents**

¹You can change these settings for a policy or for a specific computer. To change the settings for a policy, go to the Policies page and double-click the policy that you want to edit (or select the policy and click Details). To change the settings for a computer, go to the Computers page and double-click the computer that you want to edit (or select the computer and click Details).

The following example would include both streams from the demonstration above:

```
<include key="**/sample.txt" />
```

To include or exclude specific streams, the ":" notation is used. The following example matches only the "s" stream on sample.txt and not the main sample.txt stream:

```
<include key="**/sample.txt:s" />
```

Pattern matching is supported for the stream notation. The following example would include sample.txt, but exclude all of its alternate streams:

```
<include key="**/sample.txt" />  
<exclude key="**/sample.txt:*" />
```

Meaning of "Key"

Key is a pattern to match against the path of the file relative to the directory specified by "base". This is a hierarchical pattern, with sections of the pattern separated by "/" matched against sections of the path separated by the file separator of the given OS

Sub Elements

- **Include**
- **Exclude**

See ["About the Integrity Monitoring rules language" on page 989](#) for a general description of Include and Exclude for their allowed attributes and sub elements. Only information specific to includes and excludes relating to the FileSet Entity Set class are included here.

Special attributes of Include and Exclude for FileSets:

executable

Determines if the file is executable. This does not mean that its permissions allow it to be executed. Instead the contents of the file are checked, as appropriate for platform, to determine if the file is an executable file.

Note: This is a relatively expensive operation since it requires the Agent to open the file and examine the first kilobyte or two of its content looking for a valid executable image header. Opening and reading every file is much more expensive than simply scanning directories and

matching file names based on wild card patterns, so any include and exclude rules using "executable" will result in slower scan times than those that do not use it.

GroupSet

Note: The Integrity Monitoring module scans for unexpected changes to [directories](#), [registry values](#), [registry keys](#), [services](#), [processes](#), [installed software](#), [ports](#), [groups](#), [users](#), [files](#), and the [WQL](#) query statement on Deep Security Agents. To enable and configure Integrity Monitoring, see "[Set up Integrity Monitoring](#)" on page 977.

GroupSet represents a set of groups. Note these are local groups only.

Tag Attributes

These are XML attributes of the tag itself, as opposed to the attributes of the Entity monitored by Integrity Monitoring Rules.

Attribute	Description	Required	Default Value	Allowed Values
onChange	Will be monitored in real time	No	false	true, false

Entity Set Attributes

These are the attributes of the entity that can be monitored:

- **Description:** (Windows only) The textual description of the group.
- **Group:** The group ID and name. The group name is part of the entity key, but it's still important to be able to monitor the group ID-name pairing in case groups are renamed and given new IDs. Operating systems generally enforce security based on its ID.
- **Members:** A comma separated list of the members of the group.
- **SubGroups:** (Windows only) A comma separated list of sub-groups of the group.

Short Hand Attributes

- **Standard:** Group Members SubGroups

Meaning of "Key"

The key is the group's name. This is not a hierarchical Entity Set. Patterns are applied only to the group name. As a result the "*" pattern is not applicable. The following example monitors the

"Administrators" group for additions and deletions. (The "Member" attribute is included implicitly because it is a part of the STANDARD set, and no attributes are explicitly listed.)

```
<GroupSet>
  <include key="Administrators" />
</GroupSet>
```

Include and Exclude

See ["About the Integrity Monitoring rules language" on page 989](#) for a general description of Include and Exclude and their allowed attributes and sub elements.

InstalledSoftwareSet

Note: The Integrity Monitoring module scans for unexpected changes to [directories](#), [registry values](#), [registry keys](#), [services](#), [processes](#), [installed software](#), [ports](#), [groups](#), [users](#), [files](#), and the [WQL](#) query statement on Deep Security Agents. To enable and configure Integrity Monitoring, see ["Set up Integrity Monitoring" on page 977](#).

Represents a set of installed software. The "key" used to uniquely identify an installed application is platform-specific, but it is often a shorthand version of the application name or a unique numeric value.

On Windows, the key can be something readable like "FogBugz Screenshot_is1" or it can be a GUID like

"{90110409-6000-11D3-8CFE-0150048383C9}". You can examine these by looking at the sub-keys of HKEY_LOCAL_MACHINE\SOFTWARE\Microsoft\Windows\CurrentVersion\Uninstall

On Linux the key is the RPM package name, as shown by the command:

```
rpm -qa --qf "%{NAME}\n"
```

On Solaris the key is the package name as shown by the **pkginfo** command.

Tag Attributes

These are XML attributes of the tag itself, as opposed to the attributes of the computer where Integrity Monitoring is enabled.

Attribute	Description	Required	Default Value	Allowed Values
onChange	Will be monitored in real time	No	false	true, false

Entity Set Attributes

These are the attributes of the Entity that can be monitored by Integrity Monitoring Rules. Presence of the attributes is dependent on both the platform and the application itself - installation programs do not necessarily populate all of the attributes.

- **Manufacturer:** The publisher or manufacturer of the application
- **Name:** The friendly name or display name of the application. (Not available on Linux.)
- **InstalledDate:** Date of installation. This is normally returned as YYYY-MM-DD [HH:MM:SS], but many installers on Windows format the date string in a different manner so this format is not guaranteed. (Not available on AIX.)
- **InstallLocation:** The directory where the application is installed. (Only available on Windows and Solaris.)
- **Parent:** For patches and updates, this gives the key name of this item's parent. (Only available on Windows.)
- **Size:** The estimated size of the application, if available. On Windows this attribute is read from the "EstimatedSize" registry value under HKEY_LOCAL_MACHINE\SOFTWARE\Microsoft\Windows\CurrentVersion\Uninstall*. The value in that location is expressed in KB, so the Agent multiplies it by 1024 before returning the value. Note that not all Windows applications populate the EstimatedSize field in the registry. (Not available on AIX.)
- **Version:** The version of the installed application. On Windows, this comes from the "DisplayVersion" registry value.

Short Hand Attributes

These are the short hand attributes of the Entity and the attributes to which they resolve

- **STANDARD:** InstalledDate, Name, Version

Meaning of "Key"

The key is the name of the installed software. This is not a hierarchical key, so the ** pattern does not apply. On Windows the key is often a GUID, especially for anything installed via the Windows Installer (aka MSI). Use the name="XXX" feature if you need to include or exclude based on the display name rather than the GUID.

The following example would monitor for the addition and deletion of new software.

```
<InstalledSoftwareSet>  
<include key="*" />
```

```
<attributes/>
</InstalledSoftwareSet>
```

Sub Elements

- **Include**
- **Exclude**

See "[About the Integrity Monitoring rules language](#)" on page 989 for a general description of Include and Exclude for their allowed attributes and sub elements. Only information specific to includes and excludes relating to this EntitySet class are included here.

Special attributes of Include and Exclude for InstalledSoftwareSets:

name (Windows only)

Allows wildcard matching using ? and * on the display name of the application (the "name" attribute of the Entity). For example:

```
<InstalledSoftwareSet>
  <include name="Microsoft*" />
</InstalledSoftwareSet>
```

will match all installed applications whose display name (as shown by the Control Panel) starts with "Microsoft".

manufacturer

Allows wildcard matching using ? and * on the publisher or manufacturer of the application. For example:

```
<InstalledSoftwareSet>
  <include manufacturer="* Company " />
</InstalledSoftwareSet>
```

will match all installed applications whose manufacturer ends with " Company ".

PortSet

Note: The Integrity Monitoring module scans for unexpected changes to [directories](#), [registry values](#), [registry keys](#), [services](#), [processes](#), [installed software](#), [ports](#), [groups](#), [users](#), [files](#), and the [WQL](#) query statement on Deep Security Agents. To enable and configure Integrity Monitoring, see "[Set up Integrity Monitoring](#)" on page 977.

Represents a set of listening ports.

Tag Attributes

These are XML attributes of the tag itself, as opposed to the attributes of the Entity monitored by Integrity Monitoring Rules.

Attribute	Description	Required	Default Value	Allowed Values
onChange	Will be monitored in real time	No	false	true, false

Entity Set Attributes

These are the attributes of the Entity that can be monitored by Integrity Monitoring Rules.

- **Created:** Windows only - XP SP2+ and Server 2003 SP1+ required. Returned by the GetExtendedTcpTable() or GetExtendedUdpTable() functions of the Windows API. Indicates when the bind operation that created this TCP or UDP link occurred.
- **Listeners:** The number of active listeners on this protocol, IP address, and port number combination. This reflects the number of sockets bound-to and listening-on the given port, and may be greater than the number of processes listening on the port if processes bind multiple sockets to the port. This attribute has no value if only one socket is bound to the given port.
- **Path:** (Windows only - XP SP2+ and Server 2003 SP1+ required.) Gives the full path, if available, of the module that owns the port. On Windows this comes from the GetOwnerModuleFromXxxEntry() functions of the Windows API. According to Microsoft documentation, the resolution of connection table entries to owner modules is a best practice.
- **Process:** (Windows only - XP SP2+ and Server 2003 SP1+ required.) Gives the short name, if available, of the module that owns the port. On Windows this comes from the GetOwnerModuleFromXxxEntry() functions of the Windows API. According to Microsoft documentation, the resolution of connection table entries to owner modules is a best practice. In a few cases, the owner module name returned can be a process name, such as "svchost.exe", a service name (such as "RPC"), or a component name, such as "timer.dll".
- **ProcessId:** (Windows only - XP SP2+ and Server 2003 SP1+ required.) Gives the PID of the process that issued the bind for this port.
- **User:** (Linux only). Gives the user that owns the port.

Meaning of "Key"

The key is in the following format:

<PROTOCOL>/<IP ADDRESS>/<PORT>

For example:

```
tcp/172.14.207.94/80
udp/172.14.207.94/68
```

IPV6

If the IP address is IPv6 the key is in the same format, but the protocol is TCP6 or UDP6 and the IP address is an IPv6 address as returned by the `getnameinfo` command:

```
tcp6/3ffe:1900:4545:3:200:f8ff:fe21:67cf/80
udp6/3ffe:1900:4545:3:200:f8ff:fe21:67cf/68
```

Matching of the Key

This is not a hierarchical key, so `**` is not applicable. Unix-style glob matching is possible using `*` and `?`. The following pattern matches port 80 on the IP addresses 72.14.207.90 through 72.14.207.99:

```
*/72.14.207.9?/80
```

The following pattern matches port 80 on the IP addresses 72.14.207.2, 72.14.207.20 through 72.14.207.29 as well as 72.14.207.200 through 72.14.207.255:

```
*/72.14.207.2*/80
```

The following pattern matches port 80 on any IP.

```
*/80
```

The following example would monitor for any change in the listening ports but ignore port 80 for TCP in IPv4 and IPv6:

```
<PortSet>
  <include key="*" />
  <exclude key="tcp*/*/80" />
</PortSet>
```

Sub Elements

- **Include**
- **Exclude**

See ["About the Integrity Monitoring rules language" on page 989](#) for a general description of Include and Exclude and their allowed attributes and sub elements. Only information specific to includes and excludes relating to this EntitySet class are included here.

Special attributes of Include and Exclude for PortSets:

Various other attributes of the port may be used in include and exclude feature tests. These tests compare a value against the value of an attribute of the port; take note of the platform support for various attributes - not all attributes are available across platforms or even platform revisions, hence the use of these tests in include and exclude tags is of limited use. The feature tests support Unix glob-style wildcarding with * and ?, and there is no normalization of path separators or other characters - it is a simple match against the value of the attribute.

Path

Checks for a wildcard match against the path attribute of the port. The following example would monitor ports owned by processes running the main IIS binary:

```
<PortSet>
  <include path="*\system32\inetsrv\inetinfo.exe"/>
</PortSet>
```

Process

Checks for a wildcard match against the process attribute of the port. The following example would monitor ports owned by anything running in a svchost.exe or outlook.* binary:

```
<PortSet>
  <include process="svchost.exe"/>
  <include process="outlook.*"/>
</PortSet>
```

User

Checks for a wildcard match against the user attribute of the port. The following example would monitor ports on a Unix system that were owned by the super-user (root):

```
<PortSet>
  <include user="root"/>
</PortSet>
```

ProcessSet

Note: The Integrity Monitoring module scans for unexpected changes to [directories](#), [registry values](#), [registry keys](#), [services](#), [processes](#), [installed software](#), [ports](#), [groups](#), [users](#), [files](#), and the [WQL](#) query statement on Deep Security Agents. To enable and configure Integrity Monitoring, see "[Set up Integrity Monitoring](#)" on page 977.

Represents a set of processes.

Tag Attributes

These are XML attributes of the tag itself, as opposed to the attributes of the Entity monitored by Integrity Monitoring Rules.

Attribute	Description	Required	Default Value	Allowed Values
onChange	Will be monitored in real time	No	false	true, false

Entity Set Attributes

These are the attributes of the Entity that can be monitored by Integrity Monitoring Rules.

- **CommandLine:** The full command-line as shown by "ps -f" (Unix), "ps w" (Linux), or Process Explorer (Windows).
- **Group:** The group under which the process is running.
 - Under Unix this is the "effective" group ID of the process, which determines shared resource access and, in some cases, file access. Group ID can change if the process drops privileges or otherwise switches its effective group credentials. For example, a program could change group IDs temporarily and obtain write privileges to copy installation files into a directory where the user has read-only privileges.
 - On Windows this is the "current" Primary Group of the process as established by a user-specific access token created at login, which sets access and resource privileges for the user and any processes they execute.

Note: In addition to a Primary Group, Windows processes typically have one or more additional group credentials associated with them. These additional group credentials are not monitored by the Agent - they can be viewed in the Security tab of the process properties in [Process Explorer](#).

- **Parent:** The PID of the process that created this process.

- **Path:** The full path to the binary of the process. On Windows, this comes from the `GetModuleFileNameEx()` API. On Linux and Solaris 10, it comes from reading the symlink `/proc/{pid}/exe` or `/proc/{pid}/path/a.out` respectively. (Not available on Solaris 9 and AIX.)
- **Process:** The short name of the process binary (no path). For example, for `"c:\windows\notepad.exe"` it would be `"notepad.exe"` and for `"/usr/local/bin/httpd"` it would be `"httpd"`.
- **Threads:** The number of threads currently executing in the process.
- **User:** The user under which the process is running. Under Unix this is the "effective" user ID of the process, which can change over time if the process drops privileges or otherwise switches its effective user credentials.

Short Hand Attributes

- **STANDARD:** `CommandLine`, `Group`, `Parent`, `Path` (where available), `Process User`

Meaning of "Key"

The key is a combination of the "Process" attribute (the short name of the executable) and the PID. The PID is appended to the name with a path separator in between, ex. `notepad.exe\1234` on Windows and `httpd/1234` on Unix. The use of the path separator is to allow include or exclude matching of `key="abc/*"` to work as expected.

Sub Elements

- **Include**
- **Exclude**

See ["About the Integrity Monitoring rules language" on page 989](#) for a general description of include for their allowed attributes and sub elements. Only information specific to includes and excludes relating to this EntitySet class are included here.

Special attributes of Include and Exclude for ProcessSets:

The following example would monitor the set of running processes for `notepad.exe` regardless of the PID.

```
<ProcessSet>
  <include key="notepad.exe\*" />
</ProcessSet>
```

Various other attributes of a process can be used in include and exclude feature tests. The feature tests support Unix glob-style wildcarding with * and ?, and there is no normalization of path separators or other characters - it is a simple glob-style match against the value of the attribute.

CommandLine

Checks for a wildcard match against the commandLine attribute of the process. The following example would monitor any process whose command-line matches "*httpd *":

```
<ProcessSet>
  <include commandLine="*httpd *" />
</ProcessSet>
```

Group

Checks for a wildcard match against the group attribute of the process. The text version of the group name is used rather than the numeric form: use "daemon" rather than "2" to test for the daemon group on Linux. The following example would monitor any process running as one of the groups root, daemon, or lp:

```
<ProcessSet>
  <include group="root" />
  <include group="daemon" />
  <include group="lp" />
</ProcessSet>
```

Path

Checks for a wildcard match against the path attribute of the process. The path attribute is not available on some platforms. The following example would monitor any process whose binary resides under System32:

```
<ProcessSet>
  <include path="*\System32\*" />
</ProcessSet>
```

User

Checks for a wildcard match against the user attribute of the process. The text version of the user name is used rather than the numeric form: use "root" rather than "0" (zero) to test for the superuser on Unix. The following example would monitor any process running as one of the built

in system users (ex. NT AUTHORITY\SYSTEM, NT AUTHORITY\LOCAL SERVICE, NT AUTHORITY\NETWORK SERVICE):

```
<ProcessSet>
  <include user="NT AUTHORITY\*" />
</ProcessSet>
```

RegistryKeySet

Note: The Integrity Monitoring module scans for unexpected changes to [directories](#), [registry values](#), [registry keys](#), [services](#), [processes](#), [installed software](#), [ports](#), [groups](#), [users](#), [files](#), and the [WQL](#) query statement on Deep Security Agents. To enable and configure Integrity Monitoring, see "[Set up Integrity Monitoring](#)" on page 977.

The RegistryKeySet tag describes a set keys in the registry (Windows only).

Tag Attributes

These are XML attributes of the tag itself, as opposed to the attributes of the Entity monitored by Integrity Monitoring Rules.

Attribute	Description	Required	Default Value	Allowed Values
base	Sets the base key of the RegistryKeySet. Everything else in the tag is relative to this key. The base must begin with one of the following registry branch names: HKEY_CLASSES_ROOT (or HKCR), HKEY_LOCAL_MACHINE (or HKLM), HKEY_USERS (or HKU), HKEY_CURRENT_CONFIG (or HKCC)	Yes	N/A	String values resolving to syntactically valid registry key path

Entity Set Attributes

These are the attributes of the Entity that can be monitored by Integrity Monitoring Rules.

- Owner
- Group
- Permissions
- LastModified ("LastWriteTime" in Windows registry terminology)
- Class
- SecurityDescriptorSize

Short Hand Attributes

- **STANDARD:** Group, Owner, Permissions, LastModified

Meaning of "Key"

Registry Keys are stored hierarchically in the registry, much like directories in a file system. For the purpose of this language the "key path" to a key is considered to look like the path to a directory. For example the "key path" to the "Deep Security Agent" key of the Agent would be:

```
HKEY_LOCAL_MACHINE\SOFTWARE\Trend Micro\Deep Security Agent
```

The "key" value for includes and excludes for the RegistryValueSet is matched against the key path. This is a hierarchical pattern, with sections of the pattern separated by "/" matched against sections of the key path separated by "\".

Sub Elements

- Include
- Exclude

See ["About the Integrity Monitoring rules language" on page 989](#) for a general description of include for their allowed attributes and sub elements.

RegistryValueSet

Note: The Integrity Monitoring module scans for unexpected changes to [directories](#), [registry values](#), [registry keys](#), [services](#), [processes](#), [installed software](#), [ports](#), [groups](#), [users](#), [files](#), and the [WQL](#) query statement on Deep Security Agents. To enable and configure Integrity Monitoring, see ["Set up Integrity Monitoring" on page 977](#).

A set of Registry values (Windows only).

Tag Attributes

These are XML attributes of the tag itself as opposed to the attributes of the entity monitored by Integrity Monitoring Rules.

Attribute	Description	Required	Default Value	Allowed Values
base	Sets the base key of the RegistryValueSet. Everything else in the tag is relative to this key.	Yes	N/A	String values resolving to

Attribute	Description	Required	Default Value	Allowed Values
	The base must begin with one of the registry branch names: HKEY_CLASSES_ROOT (or HKCR), HKEY_LOCAL_MACHINE (or HKLM), HKEY_USERS (or HKU), HKEY_CURRENT_CONFIG (or HKCC)			syntactically valid registry key

Entity Set Attributes

These are the attributes of the Entity that can be monitored by Integrity Monitoring Rules:

- Size
- Type
- Sha1
- Sha256
- Md5 (deprecated)

Short Hand Attributes

- **CONTENTS:** Resolves to the content hash algorithm set in **Computer or Policy editor**¹ > **Integrity Monitoring > Advanced.**
- **STANDARD:** Size, Type, Contents

Meaning of "Key"

Registry Values are name-value pairs stored under a key in the registry. The key under which they are stored may in turn be stored under another key, very much like files and directories on a file system. For the purpose of this language the "key path" to a value is considered to look like the path to a file. For example, the "key path" to the InstallationFolder value of the Agent would be:

```
HKEY_LOCAL_MACHINE\SOFTWARE\Trend Micro\Deep Security
Agent\InstallationFolder
```

¹You can change these settings for a policy or for a specific computer. To change the settings for a policy, go to the Policies page and double-click the policy that you want to edit (or select the policy and click Details). To change the settings for a computer, go to the Computers page and double-click the computer that you want to edit (or select the computer and click Details).

The "key" value for includes and excludes for the RegistryValueSet is matched against the key path. This is a hierarchical pattern, with sections of the pattern separated by "/" matched against sections of the key path separated by "\"

Default Value

Each registry key has an unnamed or default value.

This value can be explicitly specified for inclusion and exclusion by using a trailing "/" in patterns. For example, "**/" will match all subordinate unnamed values, and "**Agent/**/" will match all unnamed values below a key matching "**Agent".

Note: Registry value names can contain any printable character, including quotes, backslash, the "@" symbol, etc.

The Agent deals with this in Entity key names by using backslash as an escape character, but only backslashes themselves are escaped. It does this so that it can tell the difference between a value name containing a backslash and a backslash that occurs as part of the registry path. This means that value names which end with a backslash character will match rules designed to match the default or unnamed value.

See the table below for example registry value names and the resulting Entity key.

Value	Escaped Form	Example
Hello	Hello	HKLM\Software\Sample\Hello
"Quotes"	"Quotes"	HKLM\Software\Sample\"Quotes"
back\slash	back\\slash	HKLM\Software\Sample\back\\slash
trailing\	trailing\\	HKLM\Software\Sample\trailing\\
		HKLM\Software\Sample\
@	@	HKLM\Software\Sample\@

Sub Elements

- Include
- Exclude

See ["About the Integrity Monitoring rules language" on page 989](#) for a general description of Include and Exclude for their allowed attributes and sub elements.

ServiceSet

Note: The Integrity Monitoring module scans for unexpected changes to [directories](#), [registry values](#), [registry keys](#), [services](#), [processes](#), [installed software](#), [ports](#), [groups](#), [users](#), [files](#), and the [WQL](#) query statement on Deep Security Agents. To enable and configure Integrity Monitoring, see "[Set up Integrity Monitoring](#)" on page 977.

The ServiceSet element represents a set of services (Windows only). Services are identified by the "service name", which is not the same as the "name" column shown in the Services administrative tool. The service name can be seen in the service properties and is often shorter than the value shown in the "name" column, which is actually the "Display Name" of the service. For example, the Agent has a service name of "ds_agent" and a display name of "Trend Micro Deep Security Agent".

Tag Attributes

These are XML attributes of the tag itself, as opposed to the attributes of the Entity monitored by Integrity Monitoring Rules.

Attribute	Description	Required	Default Value	Allowed Values
onChange	Will be monitored in real time	No	false	true, false

Entity Set Attributes

These are the attributes of the Entity that can be monitored by Integrity Monitoring Rules.

- **Permissions:** The service's security descriptor in [SDDL](#) format.
- **Owner:** User ID of the service owner
- **Group:** Group ID of the service owner
- **BinaryPathName:** The path plus optional command-line arguments that Windows uses to start the service.
- **DisplayName:** The "display name" of the service as shown in the properties panel of the service.
- **Description:** Description as it appears in the Services panel
- **State:** The current state of the service. One of: stopped, starting, stopping, running, continuePending, pausePending, paused
- **StartType:** How is the service started? One of: automatic, disabled, manual.

- **LogOnAs:** The name of the account that the service process will be logged on as when it runs.
- **FirstFailure:** Action to take the first time the service fails. Format is "delayInMsec,action", where action is one of None, Restart, Reboot, RunCommand.
- **SecondFailure:** Action to take the second time the service fails. Format is "delayInMsec,action", where action is one of None, Restart, Reboot, RunCommand.
- **SubsequentFailures:** Action to take if the service fails for a third or subsequent time. Format is "delayInMsec,action", where action is one of None, Restart, Reboot, RunCommand.
- **ResetFailCountAfter:** Time after which to reset the failure count to zero if there are no failures, in seconds.
- **RebootMessage:** Message to broadcast to server users before rebooting in response to the "Reboot" service controller action.
- **RunProgram:** Full command line of the process to execute in response to the RunCommand service controller action.
- **DependsOn:** Comma separated list of components that the service depends on
- **LoadOrderGroup:** The load ordering group to which this service belongs. The system startup program uses load ordering groups to load groups of services in a specified order with respect to the other groups. The list of load ordering groups is contained in the following registry value: HKEY_LOCAL_MACHINE\System\CurrentControlSet\Control\ServiceGroupOrder
- **ProcessId:** This is the numeric ID of the process that hosts the service. Many services may exist in a single Windows process, but for those that run in their own process, the monitoring of this attribute will allow the system to log service restarts.

Short Hand Attributes

These are the short hand attributes of the Entity and the attributes to which they resolve

- **STANDARD:** Permissions, Owner, Group, BinaryPathName, Description, State, StartType, LogOnAs, FirstFailure, SecondFailure, SubsequentFailures, ResetFailCountAfter, RunProgram, DependsOn, LoadOrderGroup, ProcessId

Meaning of "Key"

The key is the Service's name, which is not necessarily the same as the "name" column shown in the Services administrative tool (that tool shows the "display name" of the service). The

service name can be seen in the service properties and is often shorter than the value shown in the "name" column.

Note: This is not a hierarchical Entity Set. Patterns are applied only to the service name. As a result the ** pattern is not applicable.

Sub Elements

- Include
- Exclude

See "[About the Integrity Monitoring rules language](#)" on page 989 for a general description of include for their allowed attributes and sub elements. Only information specific to includes and excludes relating to this Entity Set class are included here.

Special attributes of Include and Exclude for ServiceSets:

state

Include or exclude based on whether the state of the service (stopped, starting, stopping, running, continuePending, pausePending, paused). The following example would monitor the set of running services for change:

```
<ServiceSet>
  <include state="running"/>
</ServiceSet>
```

UserSet

Note: The Integrity Monitoring module scans for unexpected changes to [directories](#), [registry values](#), [registry keys](#), [services](#), [processes](#), [installed software](#), [ports](#), [groups](#), [users](#), [files](#), and the [WQL](#) query statement on Deep Security Agents. To enable and configure Integrity Monitoring, see "[Set up Integrity Monitoring](#)" on page 977.

The UserSet element represents a set of users. On a Windows system it operates on users local to the system - the same users displayed by the "Local Users and Groups" MMC snap-in. Note that these are *local* users only if the Deep Security Agent is running on something other than a domain controller. On a domain controller, a UserSet element will enumerate all of the domain users, which may not be advisable for extremely large domains.

On Unix systems, the users monitored are whatever the "getpwent_r()" and "getspnam_r()" APIs have been configured to return. On AIX systems specifically, the users monitored are those listed in the `/etc/passwd` file.

Tag Attributes

These are XML attributes of the tag itself, as opposed to the attributes of the Entity monitored by Integrity Monitoring Rules.

Attribute	Description	Required	Default Value	Allowed Values
onChange	Will be monitored in real time	No	false	true, false

Entity Set Attributes

These are the attributes of the entity that can be monitored:

Common Attributes

- **cannotChangePassword:** True or false indicating if the user is permitted to change their password.
- **disabled:** True or false indicating if the account has been disabled. On Windows systems this reflects the "disabled" check box for the user. On Unix systems this will be true if the user's account has expired or if their password has expired and they've exceeded the inactivity grace period for changing it.
- **fullName:** The display name of the user.
- **groups:** A comma-separated list of the groups to which the user belongs.
- **homeFolder:** The path to the home folder or directory.
- **lockedOut:** True or false indicating if the user has been locked out, either explicitly or due to excessive failed password attempts.
- **passwordHasExpired:** True or false indicating if the user's password has expired. Note that on Windows this attribute is only available on Windows XP and newer operating systems.
- **passwordLastChanged:** The timestamp of the last time the user's password was changed. This is recorded by the Deep Security Agent as the number of milliseconds since Jan 1 1970 UTC - Deep Security Manager renders the timestamp in local time based on this value. Note that on Unix platforms, the resolution of this attribute is one day, so the time component of the rendered timestamp is meaningless. (Not supported by AIX.)
- **passwordNeverExpires:** True or false indicating if the password does not expire.

- **user:** The name of the user as known to the operating system. For example, "Administrator" or "root".

Windows-only Attributes

- **description:** The primary group the user belongs to.
- **homeDriveLetter:** The drive letter to which a network share is mapped as the user's home folder.
- **logonScript:** The path to a script that executes every time the user logs in.
- **profilePath:** A network path if roaming or mandatory Windows user profiles are being used.

Linux, AIX, and Solaris Attributes

- **group:** The primary group the user belongs to.
- **logonShell:** The path to the shell process for the user.
- **passwordExpiredDaysBeforeDisabled:** The number of days after the user's password expires that the account is disabled. On Solaris, this attribute refers to the number of inactive days before the user is disabled. (Not supported by AIX.)
- **passwordExpiry:** The date on which the user's account expires and is disabled.
- **passwordExpiryInDays:** The number of days after which the user's password must be changed.
- **passwordMinDaysBetweenChanges:** The minimum number of days permitted between password changes.
- **passwordWarningDays:** The number of days before the user's password is to expire that user is warned.

Short Hand Attributes

- **Standard:**
 - cannotChangePassword
 - disabled
 - groups
 - homeFolder
 - passwordHasExpired
 - passwordLastChanged

- passwordNeverExpires
- user
- logonScript (Windows-only)
- profilePath (Windows-only)
- group (Linux-only)
- logonShell (Linux-only)
- passwordExpiryInDays (Linux-only)
- passwordMinDaysBetweenChanges (Linux-only)

Meaning of "Key"

The key is the username. This is not a hierarchical EntitySet. Patterns are applied only to the user name. As a result the "*" pattern is not applicable.

The following example monitors for any user creations or deletions. (Note that attributes are explicitly excluded so group membership would not be tracked):

```
<UserSet>
  <Attributes/>
  <include key="*" />
</UserSet>
```

The following example would track the creation and deletion of the "jsmith" account, along with any changes to the STANDARD attributes of the account (since the STANDARD set for this EntitySet is automatically included if no specific attribute list is included):

```
<UserSet>
  <include key="jsmith" />
</UserSet>
```

Sub Elements

Include and Exclude

See ["About the Integrity Monitoring rules language" on page 989](#) for a general description of include for their allowed attributes and sub elements.

Special attributes of Include and Exclude for UserSets

Various other attributes of the user may be used in include and exclude feature tests. These tests compare a value against the value of an attribute of the user; take note of the platform support for various attributes - not all attributes are available across platforms or even platform revisions, hence the use of these tests in include and exclude elements is of limited use. The feature tests support Unix glob-style wildcarding with * and ?, and there is no normalization of path separators or other characters - it is a simple match against the value of the attribute.

- **Disabled:** Does true or false match the disabled attribute of the user. The following example monitors users with a primary group of either "users" or "daemon":

```
<UserSet>
  <include disabled="true"/>
</UserSet>
```

- **Group:** Does a wildcard match against the primary group of the user. This test is only applicable on Unix systems. The following example would monitor users with a primary group of either "users" or "daemon".

```
<UserSet>
  <include group="users"/>
  <include group="daemon"/>
</UserSet>
```

- **LockedOut:** Does a true or false match against the lockedOut attribute of the user.
- **PasswordHasExpired:** Does a true or false match against the passwordHasExpired attribute of the user.
- **PasswordNeverExpires:** Does a true or false match against the passwordNeverExpires attribute of the user.

WQLSet

Note: The Integrity Monitoring module scans for unexpected changes to [directories](#), [registry values](#), [registry keys](#), [services](#), [processes](#), [installed software](#), [ports](#), [groups](#), [users](#), [files](#), and the WQL query statement on Deep Security Agents. To enable and configure Integrity Monitoring, see "[Set up Integrity Monitoring](#)" on page 977.

The WQLSet element describes a result set from a [Windows Management Instrumentation](#) WQL query statement. [WQL](#) allows SQL-like queries to be made against many different object

classes, with the results forming a table of rows where each row represents an object and each column represents the value of a specific attribute of the object.

Note: Many WMI queries consume a large amount of time and computer resources. It is easy to inadvertently issue a query that takes several minutes to complete and returns thousands of rows. It is highly recommended that all queries be tested before use in a WQLSet using a program like Powershell or [WMI Explorer](#).

Attribute	Description	Required	Default Value	Allowed Values
namespace	Sets the namespace of the WMI query.	Yes	N/A	String values representing a valid WMI namespace. The "root\cimv2" namespace is the one most commonly used when querying Windows operating system objects, but others such as "root\directory\LDAP" and "root\Microsoft\SqlServer\ComputerManagement" can be used. See here for a small script called GetNamespaces.vbs that enumerates the available WMI namespaces on a given computer.
wql	A WQL query string.	Yes	N/A	A valid WQL string. The query must include the __Path attribute for each returned object; the Agent uses the __Path attribute as the entity key when storing and reporting results, so each returned WMI object must include a __Path. If using a query string such as "SELECT * FROM ..." the __Path attribute will be available, but if using a more selective query such as "SELECT Name FROM ..." you must explicitly include __Path by writing the query as "SELECT __Path,Name FROM ...".
onChange	Whether the files returned should be monitored in real time.	No	false	true, false
provider	Optionally specifies an alternative WMI namespace provider to use.	No	none	RsopLoggingModeProvider At present this is only required/supported for group policy queries, and "RsopLoggingModeProvider" is the only supported value. Group policy queries are special since it's recommended that the

Attribute	Description	Required	Default Value	Allowed Values
				<p>RsopLoggingModeProvider be used to create a snapshot of the policy data that is present on a computer. If you create a snapshot of the policy data, the query can be performed against a consistent set of data before the system overwrites or deletes it during a refresh of policy. Creating a snapshot actually creates a new WMI namespace, so when using <code>provider="RsopLoggingModeProvider"</code> in a WQLSet, the namespace attribute should specify the suffix to be added to the created namespace. For example, a typical temporary namespace created by the <code>RsopLoggingModeProvider</code> would be <code>"\\.\Root\Rsop\NS71EF4AA3_FB96_465F_AC1C_DF9A3E9010"</code>. Specify <code>namespace="Computer"</code> to query <code>"\\.\Root\Rsop\NS71EF4AA3_FB96_465F_AC1C_DF9A3E9010\Computer"</code>.</p> <p>Since the temporary namespace is a one-time value, it hampers the ability of the Agent to detect changes since the value appears in the entity key. To avoid this, the Agent will remove the portion of the returned <code>__Path</code> value after <code>\Rsop\</code> and up to the next backslash when the <code>RsopLoggingModeProvider</code> is used. Entity keys will therefore have prefixes like <code>"\\.\Root\Rsop\Computer"</code> rather than <code>"\\.\Root\Rsop\NS71EF4AA3_FB96_465F_AC1C_DF9A3E9010\Computer"</code>.</p>
timeout	Specifies a per-row timeout in milliseconds.	No	5000	<p>1-60000</p> <p>The WMI query is performed in semisynchronous mode, where result rows are fetched one at a time and there is a timeout on the fetching of a single row. If this parameter is not specified, 5000 (5 seconds) is used as the timeout value.</p>

Entity Set Attributes

Each "row" returned by the WQL query is treated as a single Entity for Integrity Monitoring purposes, with the returned columns representing the attributes of the entity. Since WMI/WQL is an open-ended specification, there is no set list of available or supported attributes. The query and the schema of the WMI object being queried will determine the attributes being monitored.

For example, the WQLSet:

Trend Micro Deep Security On-Premise 20

```
<WQLSet namespace="Computer" wql="select * from RSOP_SecuritySettings
where precedence=1" provider="RsopLoggingModeProvider" />
```

will return attributes of:

```
ErrorCode, GPOID, KeyName, SOMID, Setting, Status, id, precedence
```

whereas a WQLSet that queries network adapters such as:

```
<WQLSet namespace="root\cimv2" wql="select * from Win32_NetworkAdapter
where AdapterTypeId = 0" />
```

will return attributes such as:

```
AdapterType, AdapterTypeId, Availability, Caption, ConfigManagerErrorCode,
ConfigManagerUserConfig, CreationClassName Description, DeviceID, Index,
Installed, MACAddress, Manufacturer, MaxNumberControlled, Name,
PNPDeviceID, PowerManagementSupported, ProductName, ServiceName,
SystemCreationClassName, SystemName, TimeOfLastReset
```

In order to reduce the load on the Agent, it is advisable to explicitly include only the attributes that require monitoring rather than use "select * ..." in queries. This also has the benefit that changes to the WMI schema to add or remove attributes will not be reported as changes to the object unless the attributes are part of the set being monitored. With "select * from Win32_Foobar", a patch to Windows that adds a new attribute to the Win32_Foobar object class would result in the next integrity scan reporting a change for every object of that class since a new attribute has appeared.

The following are some example WMI queries which return desirable Windows system entities.

Query for Windows mounted storage devices: (selecting for * will typically result in 80% returned attributes being null or duplicate values)

```
<WQLSet namespace="root\cimv2" wql="SELECT __
Path, DeviceID, VolumeName, VolumeSerialNumber, DriveType, FileSystem, Access, Me
diaType, Size, FreeSpace FROM Win32_LogicalDisk" />
```

To further the preceding query, the DriveType can be specified to isolate only certain types of mounted logical storage devices, such as type 2 which is a "Removable Disk": (like a removable USB storage drive)

```
<WQLSet namespace="root\cimv2" wql="SELECT __
```

```
Path,DeviceID,VolumeName,VolumeSerialNumber,DriveType,FileSystem,Access,MediaType,Size,FreeSpace FROM Win32_LogicalDisk WHERE DriveType=2" />
```

(See [here](#) for details on the Win32_LogicalDisk class)

USB Storage Device notes: U3 USB devices will mount both a type 2 "Removable Disk" device and a type 3 "Compact Disc" device. Also, the above query is for storage devices only. USB non-storage devices will not be included. USB memory card adapters may appear as a type 1 "No Root Directory" device. A badly or Windows incompatible USB storage device may appear as a type 1 "Unknown" device.

Query for all known System Directories where the Drive is "F:" for relevant attributes:

```
<WQLSet namespace="root\cimv2" wql="SELECT __
Path,CreationDate,LastAccessed,LastModified,Drive,Path,FileName,Caption,FileType,Readable,Writeable FROM Win32_Directory WHERE Drive='F:'" />
```

Query for all known System Files where the Drive is "F:" for relevant attributes:

```
<WQLSet namespace="root\cimv2" wql="SELECT __
Path,CreationDate,LastAccessed,LastModified,Drive,Path,FileName,Name,FileType,Readable,Writeable FROM CIM_DataFile WHERE Drive='F:'" />
```

Meaning of Key

The key is the "__Path" attribute of the returned WMI object, which is generally of the form:

```
SystemName\Namespace:WmiObjectClass.KeyAttribute=Value
[,KeyAttribute=Value...]
```

Some examples:

```
\\TEST-DESK\root\cimv2:Win32_QuickFixEngineering.HotFixID="KB958215-IE7",ServicePackInEffect="SP0"
\\TEST-DESK\ROOT\Rsop\NSF49B36AD_10A3_4F20_9541_B4C471907CE7\Computer:RSOP_RegistryValue.
Path="MACHINE\\Software\\Microsoft\\Windows\\CurrentVersion\\Policies\\System\\LegalNoticeText",precedence=1
\\TEST-DESK\root\cimv2:BRM_NetworkAdapter.DeviceID="8"
```

Include Exclude

See ["About the Integrity Monitoring rules language" on page 989](#) for a general description of "include" and "exclude" for their allowed attributes and sub elements.

For WQLSet, "include" and "exclude" sub elements should typically not be required. It is preferable to use WQL to specify the exact set of objects to be monitored since that limits the amount of work done by both the agent and the computer's WMI implementation.

The use of any include or exclude sub elements can only reduce the set of objects returned by the query; the WQL must be changed in order to return additional objects. If it is necessary to use include or exclude elements to further restrict the WQL results, "*" and "?" characters can be used as simple wildcards to match against values of the entity key.

Virtual Appliance Scan Caching

Scan Caching is used by the Virtual Appliance to maximize the efficiency of Anti-Malware and Integrity Monitoring Scans of virtual machines. Scan Caching improves the efficiency of scans by eliminating the unnecessary scanning of identical content across multiple VMs in large VMware deployments. A Scan Cache contains lists of files and other scan targets that have been scanned by a Deep Security protection module. If a scan target on a virtual machine is determined to be identical to a target that has already been scanned, the Virtual Appliance will not scan the target a second time. Attributes used to determine whether entities are identical are creation time, modification time, file size, and file name. In the case of Real-time Scan Caching, Deep Security will read partial content of files to determine if two files are identical. There is an option setting to use a file's Update Sequence Number (USN, Windows only) but its use should be limited to cloned virtual machines.

Scan Caching benefits **Integrity Monitoring** by sharing Integrity Monitoring scan results among cloned or similar virtual machines.

Scan Caching benefits **Manual Malware Scans** of cloned or similar virtual machines by increasing the speed up subsequent scans.

Scan Caching benefits **Real-Time Malware Scanning** by speeding up boot process scans and application access scans on cloned or similar virtual machines.

Scan Cache Configurations

A Scan Cache Configuration is a collection of settings that determines Expiry Time, the use of Update Sequence Numbers (USNs), files to exclude, and files to include.

Note: Virtual machines that use the same Scan Cache Configuration also share the same Scan Cache.

You can see the list of existing Scan Cache Configurations by going **Administration > System Settings > Advanced > Scan Cache Configurations** and clicking **View Scan Cache Configurations**. Deep Security comes with several preconfigured default Scan Cache Configurations. These are implemented automatically by the Virtual Appliance depending the properties of the virtual machines being protected and the types of scan being performed.

Expiry Time determines the lifetime of individual entries in a Scan Cache. The default recommended settings are one day for Manual (on-demand) or Scheduled Malware Scans, 15 mins for Real-Time Malware Scans, and one day for Integrity Monitoring Scans.

Use USN (Windows only) specifies whether to make use of Windows NTFS Update Sequence Numbers, which is a 64-bit number used to record changes to an individual file. This option should only be set for cloned VMs.

Files Included and **Files Excluded** are regular expression patterns and lists of files to be included in or excluded from the Scan Cache. Files to be scanned are matched against the include list first.

Individual files and folders can be identified by name or you can use wildcards ("*" and "?") to refer to multiple files and locations with a single expression. (Use "*" to represent any zero or more characters, and use question mark "?" to represent any single character.)

Note: The include and exclude lists only determine whether the scan of the file will take advantage of Scan Caching. The lists will not prevent a file from being scanned in the traditional way.

Malware Scan Cache Configuration

To select which Scan Cache Configuration is used by a virtual machine, open the **Computer or Policy editor**¹ and go to **Anti-Malware > Advanced > VM Scan Cache**. You can select which Scan Cache Configuration is used for Real-Time Malware Scans and which Scan Cache Configuration is used for manual and scheduled scans.

¹You can change these settings for a policy or for a specific computer. To change the settings for a policy, go to the Policies page and double-click the policy that you want to edit (or select the policy and click Details). To change the settings for a computer, go to the Computers page and double-click the computer that you want to edit (or select the computer and click Details).

Integrity Monitoring Scan Cache Configuration

To select which Scan Cache Configuration is used by a virtual machine, open the **Computer or Policy editor**¹ and go to **Integrity Monitoring > Advanced > VM Scan Cache**.

Scan Cache Settings

Scan Cache Settings are not included in a Scan Cache Configuration because they determine how the Virtual Appliance manages Scan Caches rather than how Scan Caching is carried out. Scan Cache settings are controlled at the Policy level. You can find the Scan cache settings by opening a **Policy editor**² and going to the **Settings > General > Virtual Appliance Scans** area.

Max Concurrent Scans determines the number of scans that the Virtual Appliance performs at the same time. The recommended number is five. If you increase this number beyond 10, scan performance may degrade. Scan requests are queued by the virtual appliance and carried out in the order in which they arrive. This setting applies to manual and scheduled scans.

Max On-Demand Malware Scan Cache Entries determines, for manual or scheduled malware scans, the maximum number of records that identify and describe a file or other type of scannable content to keep. One million entries use approximately 100 MB of memory.

Max Malware Real-Time Scan Cache Entries determines, for real-time malware scans, the maximum number of records that identify and describe a file or other type of scannable content to keep. One million entries use approximately 100MB of memory.

Max Integrity Monitoring Scan Cache Entries determines the maximum number of entities included in the baseline data for integrity monitoring. Two hundred thousand entities use approximately 100MB of memory.

When to change the default configuration

Scan caching is designed to avoid scanning identical files twice. Deep Security does not examine the entire contents of all files to determine if files are identical. Although when configured to do so, Deep Security can check the USN value of a file, and during Real-time Scans it will read partial content of files, it generally examines file attributes to determine if files

¹You can change these settings for a policy or for a specific computer. To change the settings for a policy, go to the Policies page and double-click the policy that you want to edit (or select the policy and click Details). To change the settings for a computer, go to the Computers page and double-click the computer that you want to edit (or select the computer and click Details).

²To open the Policy editor, go to the Policies page and double-click the policy that you want to edit (or select the policy and click Details).

are identical. It would be difficult but not impossible for some malware to make changes to a file and then restore those files attributes to what they were before the file was modified.

Deep Security limits this potential vulnerability by establishing short default cache expiry times. To strengthen the security you can use shorter expiry times on cache and you can use USN but doing so may reduce the performance benefit or require a larger cache setting. For the strongest security for VMs that you want to keep separate and never share scan results you can create dedicated policies for these VMs kind of like keeping them in separate zones. This might be appropriate if you have different departments or organizations sharing the same infrastructure. (In a multi-tenant Deep Security Manager, this is automatically enforced for each tenant.)

If you have a very large number of guest VMs per ESXi host (for example, a VDI environment), then you should monitor your disk I/O and CPU usage during scanning. If scanning takes too long, then you may need to increase the size of the cache or adjust the Scan Cache Settings until you get better performance. If you need to increase cache size, then you may need to adjust Deep Security Virtual Appliance system memory too.

Configure Log Inspection

About Log Inspection

Note: For a list of operating systems where log inspection is supported, see ["Supported features by platform" on page 360](#).

The log inspection protection module helps you identify important events that might be buried in your operating system and application logs. These events can be sent to a security information and event management (SIEM) system or centralized logging server for correlation, reporting, and archiving. All events are also securely collected in the Deep Security Manager. For more information about logging and forwarding events, see ["Configure log inspection event forwarding and storage" on page 1042](#).

The log inspection module lets you:

- Meet PCI DSS log monitoring requirements.
- Detect suspicious behavior.
- Collect events across heterogeneous environments containing different operating systems and diverse applications.

- View events such as error and informational events (disk full, service start, service shutdown, etc.).
- Create and maintain audit trails of administrator activity (administrator login or logout, account lockout, policy change, etc.).

To enable and configure log inspection, see ["Set up Log Inspection" below](#).

The log inspection feature in Deep Security enables real-time analysis of third party log files. The log inspection rules and decoders provide a framework to parse, analyze, rank and correlate events across a wide variety of systems. As with intrusion prevention and integrity monitoring, log inspection content is delivered in the form of rules included in a security update. These rules provide a high level means of selecting the applications and logs to be analyzed. To configure and examine log inspection rules, see ["Define a Log Inspection rule for use in policies" on page 1043](#).

Set up Log Inspection

To use log inspection, perform these basic steps:

1. ["Turn on the log inspection module" below](#)
2. ["Run a recommendation scan" below](#)
3. ["Apply the recommended log inspection rules" on the next page](#)
4. ["Test Log Inspection" on page 1041](#)
5. ["Configure log inspection event forwarding and storage" on page 1042](#)

For an overview of the log inspection module, see ["About Log Inspection" on the previous page](#).

Turn on the log inspection module

1. Go to **Policies**.
2. Double-click the policy for which you want to enable log inspection.
3. Click **Log Inspection > General**.
4. For **Log Inspection State**, select **On**.
5. Click **Save**.

Run a recommendation scan

Rules should be set to gather security events relevant to your requirements. When improperly set, events for this feature can overwhelm the Deep Security database if too many log entries are triggered and stored. Run a recommendation scan on the computer for recommendations about which rules are appropriate to apply.

1. Go to **Computers** and double-click the appropriate computer.
2. Click **Log Inspection > General**.
3. For **Automatically implement Log Inspection Rule Recommendations (when possible)**, you can decide whether Deep Security should implement the rules it finds by selecting **Yes** or **No**.
4. In the **Recommendations** section, click **Scan For Recommendations**. Some log inspection rules written by Trend Micro require local configuration to function properly. If you assign one of these rules to your computers or one of these rules gets assigned automatically, an alert will be raised to notify you that configuration is required.

For more information about recommendation scans, see "[Manage and run recommendation scans](#)" on page 705.

Apply the recommended log inspection rules

Deep Security ships with many pre-defined rules covering a wide variety of operating systems and applications. When you run a recommendation scan, you can choose to have Deep Security [automatically implement the recommended rules](#), or you can choose to manually select and assign the rules by following the steps below:

1. Go to **Policies**.
2. Double-click the policy that you want to configure.
3. Click **Log Inspection > General**.
4. In the **Assigned Log Inspection Rules** section, the rules in effect for the policy are displayed. To add or remove log inspection rules, click **Assign/Unassign**.

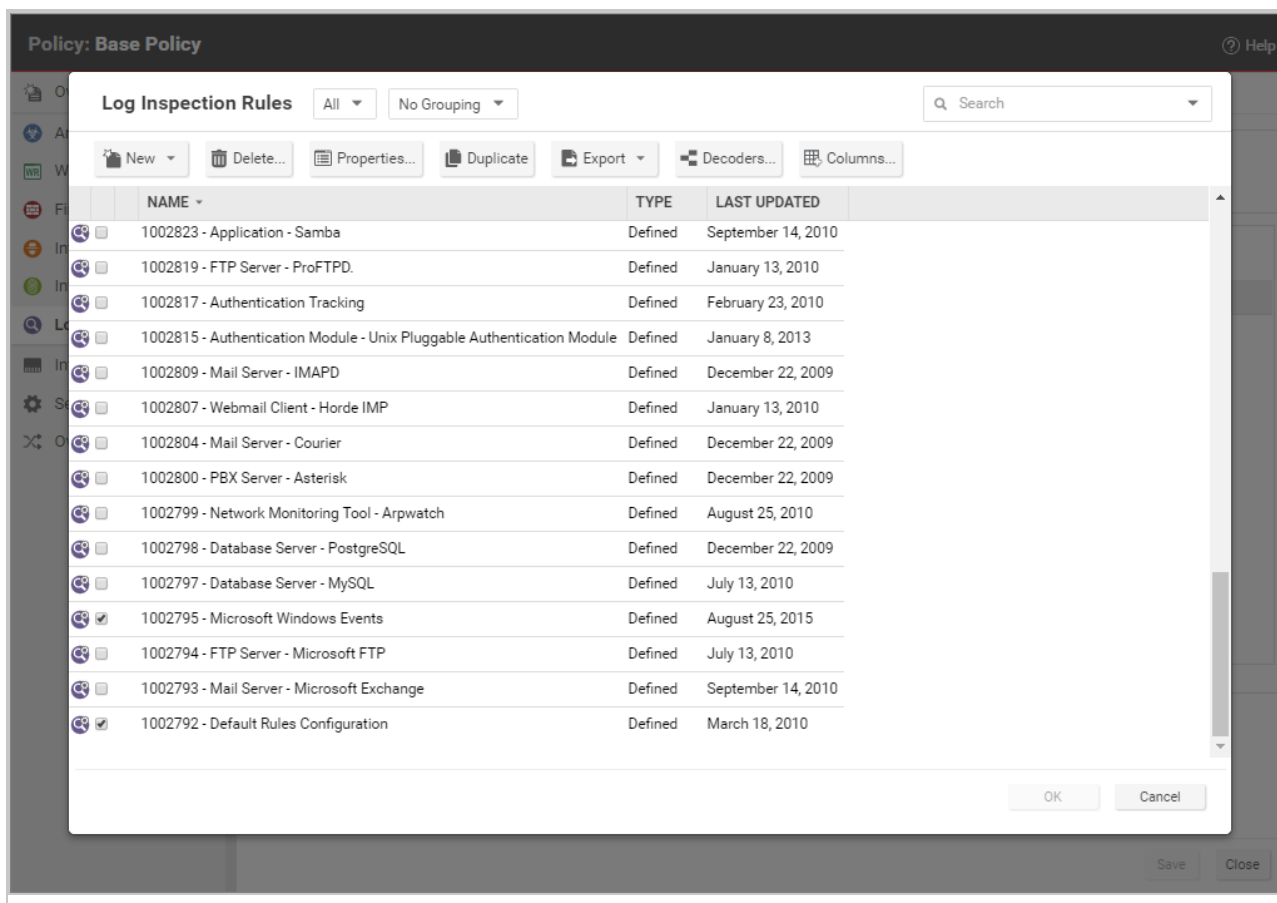

5. Select or deselect the checkboxes for the rules you want to assign or unassign. You can edit the log inspection rule by right-clicking the rule and selecting **Properties** to edit the rule locally or **Properties (Global)** to apply the changes to all other policies that are using the rule. For more information, see ["Examine a Log Inspection rule" on page 1065](#).
6. Click **OK**.

Although Deep Security ships with log inspection rules for many common operating systems and applications, you also have the option to create your own custom rules. To create a custom rule, you can either use the "Basic Rule" template, or you can write your new rule in XML. For information on how to create a custom rule, see ["Define a Log Inspection rule for use in policies" on page 1043](#).

Test Log Inspection

Before continuing with further Log Inspection configuration steps, test that the rules are working correctly:

1. Ensure Log Inspection is enabled.
2. Go to **Computer or Policies editor > Log Inspection > Advanced**. Change **Store events at the Agent/Appliance for later retrieval by DSM when they equal or exceed the following severity level** to **Low (3)** and click **Save**.
3. Go to the **General** tab, and click **Assign/Unassign**. Search for and enable:
 - 1002792 - Default Rules Configuration - This is required for all other Log Inspection rules to work.

If you're a Windows user, enable:

- 1002795 - Microsoft Windows Events - This logs events every time the Windows auditing functionality registers an event.

If you're a Linux user, enable:

- 1002831 - Unix - Syslog - This inspects the syslog for events.
4. Click **OK**, and then click **Save** to apply the rules to the policy.
 5. Attempt to log in to the server with an account that does not exist.
 6. Go to **Events & Reports > Log Inspection Events** to verify the record of the failed login attempt. If the detection is recorded, the Log Inspection module is working correctly.

Configure log inspection event forwarding and storage

When a log inspection rule is triggered, an event is logged. To view these events, go to **Events & Reports > Log Inspection Events** or **Policy editor > Log Inspection > Log Inspection Events**. For more information on working with log inspection events, see ["Log inspection events" on page 1371](#).

Depending on the severity of the event, you can choose to send them to a syslog server (For information on enabling this feature, see ["Forward Deep Security events to a Syslog or SIEM server" on page 1146](#).) or to store events in the database by using the severity clipping feature.

There are two "severity clipping" settings available:

- **Send Agent events to syslog when they equal or exceed the following severity level:** This setting determines which events triggered by those rules get sent to the syslog server, if syslog is enabled.
- **Store events at the Agent for later retrieval by Deep Security Manager when they equal or exceed the following severity level:** This setting determines which log inspection events are kept in the database and displayed in the **Log Inspection Events** page.

To configure severity clipping:

1. Go to **Policies**.
2. Double-click the policy you want to configure.
3. Click **Log Inspection > Advanced**.
4. For **Send Agent/Appliance events to syslog when they equal or exceed the following severity level**, choose a severity level between **Low (0)** and **Critical (15)**.
5. For **Store events at the Agent/Appliance for later retrieval by DSM when they equal or exceed the following severity level**, choose a severity level between **Low (0)** and **Critical (15)**.
6. Click **Save**.

Define a Log Inspection rule for use in policies

The OSSEC Log Inspection engine is integrated into Deep Security Agents and gives Deep Security the ability to inspect the logs and events generated by the operating system and applications running on the computer. Deep Security Manager ships with a standard set of OSSEC Log Inspection rules that you can assign to computers or policies. You can also create custom rules if there is no existing rule that fits your requirements.

Log Inspection Rules issued by Trend Micro are not editable (although you can duplicate them and then edit them.)

Note: Log Inspection Rules that are assigned to one or more computers or that are part of a policy cannot be deleted.

To create Log Inspection rules, perform these basic steps:

- ["Create a new Log Inspection rule" on the next page](#)
- ["Decoders" on page 1045](#)
- ["Subrules" on page 1047](#)
- ["Real world examples" on page 1054](#)
- ["Log Inspection rule severity levels and their recommended use" on page 1063](#)
- ["strftime\(\) conversion specifiers " on page 1064](#)
- ["Examine a Log Inspection rule" on page 1065](#)

For an overview of the Log Inspection module, see ["About Log Inspection" on page 1038](#).

Create a new Log Inspection rule

1. In the Deep Security Manager, go to **Policies > Common Objects > Rules > Log Inspection Rules**.
2. Click **New > New Log Inspection Rule**.
3. On the **General** tab, enter a name and an optional description for the rule.
4. The **Content** tab is where you define the rule. The easiest way to define a rule is to select **Basic Rule** and use the options provided to define the rule. If you need further customization, you can select **Custom (XML)** to switch to an XML view of the rule that you are defining.

Note: Any changes you make in the Custom (XML) view will be lost if you switch back to the Basic Rule view.

For further assistance in writing your own Log Inspection rules using the XML-based language, consult the [OSSEC](#) documentation or contact your support provider.

These options are available for the Basic Rule template:

- **Rule ID:** The Rule ID is a unique identifier for the rule. OSSEC defines 100000 - 109999 as the space for user-defined rules. Deep Security Manager will pre-populate the field with a new unique Rule ID.
- **Level:** Assign a level to the rule. Zero (0) means the rule never logs an event, although other rules that watch for this rule may fire.
- **Groups:** Assign the rule to one or more comma-separated groups. This can be useful when dependency is used because you can create rules that fire on the firing of a rule, or a rule that belongs to a specific group.
- **Rule Description:** Description of the rule.
- **Pattern Matching:** This is the pattern the rule will look for in the logs. The rule will be triggered on a match. Pattern matching supports Regular Expressions or simpler String Patterns. The "String Pattern" pattern type is faster than RegEx but it only supports three special operations:
 - **^ (caret):** specifies the beginning of text
 - **\$ (dollar sign):** specifies the end of text
 - **| (pipe):** to create a "OR" between multiple patterns

For information on the regular expression syntax used by the Log Inspection module, see <https://www.ossec.net/docs/syntax/regex.html>.

- **Dependency:** Setting a dependency on another rule will cause your rule to only log an event if the rule specified in this area has also triggered.
- **Frequency** is the number of times the rule has to match within a specific time frame before the rule is triggered.
- **Time Frame** is the period of time in seconds within which the rule has to trigger a certain number of times (the frequency, above) to log an event.

Note: The **Content** tab only appears for Log Inspection rules that you create yourself. Log Inspection rules issued by Trend Micro have a **Configuration** tab instead that displays the Log Inspection rule's configuration options (if any).

5. On the **Files** tab, type the full path to the files you want your rule to monitor and specify the type of file it is. Note that the path and file name do not support the glob character.
6. On the **Options** tab, in the **Alert** section, select whether this rule triggers an alert in the Deep Security Manager.

Alert Minimum Severity sets the minimum severity level that will trigger an Alert for rules made using the Basic Rule or Custom (XML) template.

Note: The Basic Rule template creates one rule at a time. To write multiple rules in a single template you can use the Custom (XML) template. If you create multiple rules with different Levels within a Custom (XML) template, you can use the **Alert Minimum Severity** setting to select the minimum severity that will trigger an Alert for all of the rules in that template.

7. The **Assigned To** tab lists the policies and computers that are using this Log Inspection rule. Because you are creating a new rule, it has not been assigned yet.
8. Click **OK**. The rule is ready to be assigned to policies and computers.

Decoders

A Log Inspection rule consists of a list of files to monitor for changes and a set of conditions to be met for the rule to trigger. When the Log Inspection engine detects a change in a monitored log file, the change is parsed by a decoder. Decoders parse the raw log entry into the following fields:

- **log**: the message section of the event
- **full_log**: the entire event
- **location**: where the log came from
- **hostname**: hostname of the event source
- **program_name**: program name from the syslog header of the event
- **srcip**: the source IP address within the event
- **dstip**: the destination IP address within the event
- **srcport**: the source port number within the event
- **dstport**: the destination port number within the event
- **protocol**: the protocol within the event
- **action**: the action taken within the event
- **srcuser**: the originating user within the event
- **dstuser**: the destination user within the event
- **id**: any ID decoded as the ID from the event
- **status**: the decoded status within the event
- **command**: the command being called within the event
- **url**: the URL within the event
- **data**: any additional data extracted from the event
- **systemname**: the system name within the event

Rules examine this decoded data looking for information that matches the conditions defined in the rule.

If the matches are at a sufficiently high severity level, any of the following actions can be taken:

- An alert can be raised. (Configurable on the **Options** tab of the Log Inspection Rule's **Properties** window.)
- The event can be written to syslog. (Configurable in the **SIEM** area on **Administration > System Settings > Event Forwarding** tab.)
- The event can be sent to the Deep Security Manager. (Configurable in the **Log Inspection Syslog Configuration** setting on the **Policy or Computer Editor > Settings > Event Forwarding** tab.)

Subrules

A single Log Inspection rule can contain multiple subrules. These subrules can be of two types: atomic or composite. An atomic rule evaluates a single event and a composite rule examines multiple events and can evaluate frequency, repetition, and correlation between events.

Groups

Each rule, or grouping of rules, must be defined within a `<group></group>` element. The attribute name must contain the rules you want to be a part of this group. In the following example we have indicated that our group contains the syslog and sshd rules:

```
<group name="syslog,sshd,">
</group>
```

Note: Notice the trailing comma in the group name. Trailing commas are required if you intend to use the `<if_group></if_group>` tag to conditionally append another sub-rule to this one.

Note: When a set of Log Inspection rules are sent to an agent, the Log Inspection engine on the agent takes the XML data from each assigned rule and assembles it into what becomes essentially a single long Log Inspection rule. Some group definitions are common to all Log Inspection rules written by Trend Micro. For this reason Trend Micro has included a rule called "Default Rules Configuration" which defines these groups and which always gets assigned along with any other Trend Micro rules. (If you select a rule for assignment and haven't also selected the "Default Rules Configuration" rule, a notice will appear informing you that the rule will be assigned automatically.) *If you create your own Log Inspection rule and assign it to a Computer without assigning any Trend Micro-written rules, you must either copy the content of the "Default Rules Configuration" rule into your new rule, or also select the "Default Rules Configuration" rule for assignment to the Computer.*

Rules, ID, and Level

A group can contain as many rules as you require. The rules are defined using the `<rule></rule>` element and must have at least two attributes, the **id** and the **level**. The **id** is a unique identifier for that signature and the **level** is the severity of the alert. In the following example, we have created two rules, each with a different rule ID and level:

```
<group name="syslog,sshd,">
  <rule id="100120" level="5">
</rule>
```

```

    <rule id="100121" level="6">
    </rule>
</group>

```

Note: Custom rules must have ID values of 100,000 or greater.

You can define additional subgroups within the parent group using the `<group></group>` tag. This subgroup can reference any of the groups listed in the following table:

Group Type	Group Name	Description
Reconnaissance	connection_attempt web_scan recon	Connection attempt Web scan Generic scan
Authentication Control	authentication_success authentication_failed invalid_login login_denied authentication_failures adduser account_changed	Success Failure Invalid Login Denied Multiple Failures User account added User Account changed or removed
Attack/Misuse	automatic_attack exploit_attempt invalid_access spam multiple_spam sql_injection attack virus	Worm (nontargeted attack) Exploit pattern Invalid access Spam Multiple spam messages SQL injection Generic attack Virus detected
Access Control	access_denied access_allowed unknown_resource firewall_drop multiple_drops client_misconfig client_error	Access denied Access allowed Access to nonexistent resource Firewall drop Multiple firewall drops Client misconfiguration Client error
Network Control	new_host ip_spoof	New computer detected Possible ARP spoofing
System Monitor	service_start system_error system_shutdown logs_cleared invalid_request promisc policy_changed config_changed low_diskspace time_changed	Service start System error Shutdown Logs cleared Invalid request Interface switched to promiscuous mode Policy changed Configuration changed Low disk space Time changed

Note: If event auto-tagging is enabled, the event will be labeled with the group name. Log Inspection rules provided by Trend Micro make use of a translation table that changes the group to a more user-friendly version. So, for example, "login_denied" would appear as "Login Denied". Custom rules will be listed by their group name as it appears in the rule.

Description

Include a `<description></description>` tag. The description text will appear in the event if the rule is triggered.

```
<group name="syslog,sshd,">
  <rule id="100120" level="5">
    <group>authentication_success</group>
    <description>SSHD testing authentication success</description>
  </rule>
  <rule id="100121" level="6">
    <description>SSHD rule testing 2</description>
  </rule>
</group>
```

Decoded As

The `<decoded_as></decoded_as>` tag instructs the Log Inspection engine to only apply the rule if the specified decoder has decoded the log.

```
<rule id="100123" level="5">
  <decoded_as>sshd</decoded_as>
  <description>Logging every decoded sshd message</description>
</rule>
```

Note: To view the available decoders, go to the **Log Inspection Rule** page and click **Decoders**. Right-click on **1002791-Default Log Decoders** and select **Properties**. Go the **Configuration** tab and click **View Decoders**.

Match

To look for a specific string in a log, use the `<match></match>`. Here is a Linux sshd failed password log:

```
Jan 1 12:34:56 linux_server sshd[1231]: Failed password for invalid
user jsmith from 192.168.1.123 port 1799 ssh2
```

Use the `<match></match>` tag to search for the "password failed" string.

```
<rule id="100124" level="5">
  <decoded_as>sshd</decoded_as>
  <match>^Failed password</match>
  <description>Failed SSHD password attempt</description>
</rule>
```

Note: Notice the regex caret ("`^`") indicating the beginning of a string. Although "Failed password" does not appear at the beginning of the log, the Log Inspection decoder will have broken up the log into sections. See ["Decoders" on page 1045](#) for more information. One of those sections is "log" which is the message part of the log as opposed to "full_log" which is the log in its entirety.

The following table lists supported regex syntax:

Regex Syntax	Description
<code>\w</code>	A-Z, a-z, 0-9 single letters and numerals
<code>\d</code>	0-9 single numerals
<code>\s</code>	single space
<code>\t</code>	single tab
<code>\p</code>	<code>()*+,-.::<=>?[]</code>
<code>\W</code>	not <code>\w</code>
<code>\D</code>	not <code>\d</code>
<code>\S</code>	not <code>\s</code>
<code>\.</code>	anything
<code>+</code>	match one or more of any of the above (for example, <code>\w+</code> , <code>\d+</code>)
<code>*</code>	match zero or more of any of the above (for example, <code>\w*</code> , <code>\d*</code>)
<code>^</code>	indicates the beginning of a string (<code>^somestring</code>)
<code>\$</code>	specify the end of a string (<code>somestring\$</code>)
<code> </code>	indicate an "OR" between multiple strings

Conditional Statements

Rule evaluation can be conditional upon other rules having been evaluated as true. The `<if_sid></if_sid>` tag instructs the Log Inspection engine to only evaluate this subrule if the rule identified in the tag has been evaluated as true. The following example shows three rules: 100123, 100124, and 100125. Rules 100124 and 100125 have been modified to be children of the 100123 rule using the `<if_sid></if_sid>` tag:

```
<group name="syslog,sshd,">
  <rule id="100123" level="2">
```

```

        <decoded_as>sshd</decoded_as>
        <description>Logging every decoded sshd message</description>
</rule>
<rule id="100124" level="7">
    <if_sid>100123</if_sid>
    <match>^Failed password</match>
    <group>authentication_failure</group>
    <description>Failed SSHD password attempt</description>
</rule>
<rule id="100125" level="3">
    <if_sid>100123</if_sid>
    <match>^Accepted password</match>
    <group>authentication_success</group>
    <description>Successful SSHD password attempt</description>
</rule>
</group>

```

Hierarchy of Evaluation

The `<if_sid></if_sid>` tag essentially creates a hierarchical set of rules. That is, by including an `<if_sid></if_sid>` tag in a rule, the rule becomes a child of the rule referenced by the `<if_sid></if_sid>` tag. Before applying any rules to a log, the Log Inspection engine assesses the `<if_sid></if_sid>` tags and builds a hierarchy of parent and child rules.

Note: The hierarchical parent-child structure can be used to improve the efficiency of your rules. If a parent rule does not evaluate as true, the Log Inspection engine will ignore the children of that parent.

Note: Although the `<if_sid></if_sid>` tag can be used to refer to subrules within an entirely different Log Inspection rule, you should avoid doing this because it makes the rule very difficult to review later on.

The list of available atomic rule conditional options is shown in the following table:

Tag	Description	Notes
match	A pattern	Any string to match against the event (log).
regex	A regular expression	Any regular expression to match against the event(log).
decoded_as	A string	Any prematched string.
srcip	A source IP address	Any IP address that is decoded as the source IP address. Use "!" to negate the IP address.

Tag	Description	Notes
dstip	A destination IP address	Any IP address that is decoded as the destination IP address. Use "!" to negate the IP address.
srcport	A source port number	Any source port (match format).
dstport	A destination port number	Any destination port (match format).
user	A username	Any username that is decoded as a username.
program_name	A program name	Any program name that is decoded from the syslog process name.
hostname	A system hostname	Any hostname that is decoded as a syslog hostname.
time	A time range in the format hh:mm - hh:mm or hh:mm am - hh:mm pm	The time range that the event must fall within for the rule to trigger.
weekday	A weekday (sunday, monday, tuesday, etc.)	Day of the week that the event must fall on for the rule to trigger.
id	An ID	Any ID that is decoded from the event.
url	A URL	Any URL that is decoded from the event.

Use the `<if_sid>100125</if_sid>` tag to make this rule depend on the 100125 rule. This rule will be checked only for sshd messages that already matched the successful login rule.

```
<rule id="100127" level="10">
  <if_sid>100125</if_sid>
  <time>6 pm - 8:30 am</time>
  <description>Login outside business hours.</description>
  <group>policy_violation</group>
</rule>
```

Restrictions on the Size of the Log Entry

The following example takes the previous example and adds the **maxsize** attribute which tells the Log Inspection engine to only evaluate rules that are less than the maxsize number of characters:

```
<rule id="100127" level="10" maxsize="2000">
  <if_sid>100125</if_sid>
  <time>6 pm - 8:30 am</time>
  <description>Login outside business hours.</description>
  <group>policy_violation</group>
</rule>
```

The following table lists possible atomic rule tree-based options:

Tag	Description	Notes
if_sid	A rule ID	Adds this rule as a child rule of the rules that match the specified signature ID.
if_group	A group ID	Adds this rule as a child rule of the rules that match the specified group.
if_level	A rule level	Adds this rule as a child rule of the rules that match the specified severity level.
description	A string	A description of the rule.
info	A string	Extra information about the rule.
cve	A CVE number	Any Common Vulnerabilities and Exposures (CVE) number that you would like associated with the rule.
options	alert_by_email no_email_alert no_log	Additional rule options to indicate if the Alert should generate an e-mail, alert_by_email, should not generate an email, no_email_alert, or should not log anything at all, no_log.

Composite Rules

Atomic rules examine single log entries. To correlate multiple entries, you must use composite rules. Composite rules are supposed to match the current log with those already received. Composite rules require two additional options: the **frequency** option specifies how many times an event or pattern must occur before the rule generates an alert, and the **timeframe** option tells the Log Inspection engine how far back, in seconds, it should look for previous logs. All composite rules have the following structure:

```
<rule id="100130" level="10" frequency="x" timeframe="y">
</rule>
```

For example, you could create a composite rule that creates a higher severity alert after five failed passwords within a period of 10 minutes. Using the `<if_matched_sid></if_matched_sid>` tag you can indicate which rule needs to be seen within the desired frequency and timeframe for your new rule to create an alert. In the following example, the **frequency** attribute is set to trigger when five instances of the event are seen and the **timeframe** attribute is set to specify the time window as 600 seconds.

The `<if_matched_sid></if_matched_sid>` tag is used to define which other rule the composite rule will watch:

```
<rule id="100130" level="10" frequency="5" timeframe="600">
  <if_matched_sid>100124</if_matched_sid>
  <description>5 Failed passwords within 10 minutes</description>
</rule>
```

There are several additional tags that you can use to create more granular composite rules. These rules, as shown in the following table, allow you to specify that certain parts of the event must be the same. This allows you to tune your composite rules and reduce false positives:

Tag	Description
same_source_ip	Specifies that the source IP address must be the same.
same_dest_ip	Specifies that the destination IP address must be the same.
same_dst_port	Specifies that the destination port must be the same.
same_location	Specifies that the location (hostname or agent name) must be the same.
same_user	Specifies that the decoded username must be the same.
same_id	Specifies that the decoded id must be the same.

If you wanted your composite rule to alert on every authentication failure, instead of a specific rule ID, you could replace the `<if_matched_sid></if_matched_sid>` tag with the `<if_matched_group></if_matched_group>` tag. This allows you to specify a category, such as `authentication_failure`, to search for authentication failures across your entire infrastructure.

```
<rule id="100130" level="10" frequency="5" timeframe="600">
  <if_matched_group>authentication_failure</if_matched_group>
  <same_source_ip />
  <description>5 Failed passwords within 10 minutes</description>
</rule>
```

In addition to `<if_matched_sid></if_matched_sid>` and `<if_matched_group></if_matched_group>` tags, you can also use the `<if_matched_regex></if_matched_regex>` tag to specify a regular expression to search through logs as they are received.

```
<rule id="100130" level="10" frequency="5" timeframe="600">
  <if_matched_regex>^Failed password</if_matched_regex>
  <same_source_ip />
  <description>5 Failed passwords within 10 minutes</description>
</rule>
```

Real world examples

Deep Security includes many default Log Inspection rules for dozens of common and popular applications. Through Security Updates, new rules are added regularly. In spite of the growing list of applications supported by Log Inspection rules, you may find the need to create a custom rule for an unsupported or custom application.

In this section we will walk through the creation of a custom CMS (content management system) hosted on Microsoft Windows Server with IIS and .Net platform, with a Microsoft SQL Server database as the data repository.

The first step is to identify the following application logging attributes:

1. Where does the application log to?
2. Which Log Inspection decoder can be used to decode the log file?
3. What is the general format of a log file message?

For our custom CMS example the answers are as follows:

1. Windows Event Viewer
2. Windows Event Log (eventlog)
3. Windows Event Log Format with the following core attributes:
 - Source: CMS
 - Category: None
 - Event: <Application Event ID>

The second step is to identify the categories of log events by application feature, and then organize the categories into a hierarchy of cascading groups for inspection. Not all inspected groups need to raise events; a match can be used as a conditional statement. For each group, identify the log format attributes which the rule can use as matching criteria. This can also be performed by inspecting all application logs for patterns and logical groupings of log events.

For example, the CMS application supports the following functional features which we will create Log Inspection rules for:

- CMS Application Log (Source: CMS)
 - Authentication (Event: 100 to 119)
 - User Login successful (Event: 100)
 - User Login unsuccessful (Event: 101)
 - Administrator Login successful (Event: 105)
 - Administrator Login unsuccessful (Event: 106)
 - General Errors (Type: Error)
 - Database error (Event: 200 to 205)
 - Runtime error (Event: 206-249)

- Application Audit (Type: Information)
 - Content
 - New content added (Event: 450 to 459)
 - Existing content modified (Event: 460 to 469)
 - Existing content deleted (Event: 470 to 479)
 - Administration
 - User
 - New User created (Event: 445 to 446)
 - Existing User deleted (Event: 447 to 449)

This structure will provide you with a good basis for rule creation. Now to create a new Log Inspection rule in Deep Security Manager.

To create the new CMS Log Inspection Rule:

1. In the Deep Security Manager, go to **Policies > Common Objects > Rules > Log Inspection Rules** and click **New** to display the **New Log Inspection Rule Properties** window.
2. Give the new rule a name and a description, and then click the **Content** tab.
3. The quickest way to create a new custom rule is to start with a basic rule template. Select the **Basic Rule** radio button.
4. The **Rule ID** field will be automatically populated with an unused ID number of 100,000 or greater, the IDs reserved for custom rules.
5. Set the **Level** setting to **Low (0)**.
6. Give the rule an appropriate Group name. In this case, "cms".

7. Provide a short rule description.

General	Content	Files	Options	Assigned To	
Template					
<input checked="" type="radio"/> Basic Rule					
<input type="radio"/> Custom (XML)					
General Information					
Rule ID:	<input type="text" value="100000"/>				
Level:	<input type="text" value="Low (0)"/>				
Groups (comma separated):	<input type="text" value="cms"/>				
Rule Description:	<input type="text" value="windows events for 'cms' group"/>				
Pattern Matching					
Pattern to Match:	<input type="text"/>				
Pattern Type:	<input type="text" value="String Pattern"/>				
Dependency					
<input checked="" type="radio"/> None					
<input type="radio"/> Trigger event on the triggering of another rule:					
<input type="radio"/> Trigger event on the triggering of any rule belonging to a specific group:					
Composite (optional)					
Only trigger if this rule matches its dependent rule the specified frequency of times in the specified time frame (in seconds).					
Frequency (1 to 128):	<input type="text"/>				
Time Frame (1 to 86400):	<input type="text"/>				
				<input type="button" value="OK"/>	<input type="button" value="Cancel"/>

8. Now select the **Custom (XML)** option. The options you selected for your "Basic" rule will be converted to XML.

General Content Files Options Assigned To

Template

Basic Rule
 Custom (XML)

Content:

```
<group name="cms">
  <rule id="100000" level="0">
    <description>windows events for 'cms' groups</description>
  </rule>
</group>
```

OK Cancel

9. Click the **Files** tab and click the **Add File** button to add any application log files and log types which the rule will be applied to. In this case, "Application", and "eventlog" as the file type.

General Content Files Options Assigned To

Files:

Application eventlog Remove

Add File

OK Cancel

Note: Eventlog is a unique file type in Deep Security because the location and filename of the log files don't have to be specified. Instead, it is sufficient to type the log name as it is displayed in the Windows Event Viewer. Other log names for the eventlog file type

might be "Security", "System", "Internet Explorer", or any other section listed in the Windows Event Viewer. Other file types will require the log file's location and filename. (C/C++ *strftime()* conversion specifiers are available for matching on filenames. See the table below for a list of some of the more useful ones.)

10. Click **OK** to save the basic rule.
11. Working with the basic rule Custom (XML) created, we can begin adding new rules to the group based on the log groupings identified previously. We will set the base rule criteria to the initial rule. In the following example, the CMS base rule has identified Windows Event Logs with a Source attribute of "CMS":

```
<group name="cms">
  <rule id="100000" level="0">
    <category>windows</category>
    <extra_data>^CMS</extra_data>
    <description>Windows events from source 'CMS' group
messages.</description>
  </rule>
```

12. Now we build up subsequent rules from the identified log groups. The following example identifies the authentication and login success and failure and logs by Event IDs.

```
<rule id="100001" level="0">
  <if_sid>100000</if_sid>
  <id>^100|^101|^102|^103|^104|^105|^106|^107|^108|^109|^110</id>
  <group>authentication</group>
  <description>CMS Authentication event.</description>
</rule>

<rule id="100002" level="0">
  <if_group>authentication</if_group>
  <id>100</id>
  <description>CMS User Login success event.</description>
</rule>

<rule id="100003" level="4">
  <if_group>authentication</if_group>
  <id>101</id>
  <group>authentication_failure</group>
  <description>CMS User Login failure event.</description>
</rule>
```

```

<rule id="100004" level="0">
  <if_group>authentication</if_group>
  <id>105</id>
  <description>CMS Administrator Login success event.</description>
</rule>
<rule id="100005" level="4">
  <if_group>authentication</if_group>
  <id>106</id>
  <group>authentication_failure</group>
  <description>CMS Administrator Login failure event.</description>
</rule>

```

13. Now we add any composite or correlation rules using the established rules. The follow example shows a high severity composite rule that is applied to instances where the repeated login failures have occurred 5 times within a 10 second time period:

```

<rule id="100006" level="10" frequency="5" timeframe="10">
  <if_matched_group>authentication_failure</if_matched_group>
  <description>CMS Repeated Authentication Login failure
event.</description>
</rule>

```

14. Review all rules for appropriate severity levels. For example, error logs should have a severity of level 5 or higher. Informational rules would have a lower severity.
15. Finally, open the newly created rule, click the **Configuration** tab and copy your custom rule XML into the rule field. Click **Apply** or **OK** to save the change.

Once the rule is assigned to a policy or computer, the Log Inspection engine should begin inspecting the designated log file immediately.

The complete Custom CMS Log Inspection Rule:

```

<group name="cms">
  <rule id="100000" level="0">
    <category>windows</category>
    <extra_data>^CMS</extra_data>
    <description>Windows events from source 'CMS' group
messages.</description>
  </rule>
  <rule id="100001" level="0">
    <if_sid>100000</if_sid>
    <id>^100|^101|^102|^103|^104|^105|^106|^107|^108|^109|^110</id>
    <group>authentication</group>

```

```
        <description>CMS Authentication event.</description>
</rule>

<rule id="100002" level="0">
    <if_group>authentication</if_group>
    <id>100</id>
    <description>CMS User Login success event.</description>
</rule>

<rule id="100003" level="4">
    <if_group>authentication</if_group>
    <id>101</id>
    <group>authentication_failure</group>
    <description>CMS User Login failure event.</description>
</rule>

<rule id="100004" level="0">
    <if_group>authentication</if_group>
    <id>105</id>
    <description>CMS Administrator Login success event.</description>
</rule>

<rule id="100005" level="4">
    <if_group>authentication</if_group>
    <id>106</id>
    <group>authentication_failure</group>
    <description>CMS Administrator Login failure event.</description>
</rule>

<rule id="100006" level="10" frequency="5" timeframe="10">
    <if_matched_group>authentication_failure</if_matched_group>
    <description>CMS Repeated Authentication Login failure
event.</description>
</rule>

<rule id="100007" level="5">
    <if_sid>100000</if_sid>
    <status>^ERROR</status>
    <description>CMS General error event.</description>
    <group>cms_error</group>
```

```
</rule>

<rule id="100008" level="10">
  <if_group>cms_error</if_group>
  <id>^200|^201|^202|^203|^204|^205</id>
  <description>CMS Database error event.</description>
</rule>

<rule id="100009" level="10">
  <if_group>cms_error</if_group>
  <id>^206|^207|^208|^209|^230|^231|^232|^233|^234|^235|^236|^237|^238|^239|^240|^241|^242|^243|^244|^245|^246|^247|^248|^249</id>
  <description>CMS Runtime error event.</description>
</rule>

<rule id="100010" level="0">
  <if_sid>100000</if_sid>
  <status>^INFORMATION</status>
  <description>CMS General informational event.</description>
  <group>cms_information</group>
</rule>

<rule id="100011" level="5">
  <if_group>cms_information</if_group>
  <id>^450|^451|^452|^453|^454|^455|^456|^457|^458|^459</id>
  <description>CMS New Content added event.</description>
</rule>

<rule id="100012" level="5">
  <if_group>cms_information</if_group>
  <id>^460|^461|^462|^463|^464|^465|^466|^467|^468|^469</id>
  <description>CMS Existing Content modified event.</description>
</rule>

<rule id="100013" level="5">
  <if_group>cms_information</if_group>
  <id>^470|^471|^472|^473|^474|^475|^476|^477|^478|^479</id>
  <description>CMS Existing Content deleted event.</description>
</rule>
```

```

<rule id="100014" level="5">
  <if_group>cms_information</if_group>
  <id>^445|^446</id>
  <description>CMS User created event.</description>
</rule>

<rule id="100015" level="5">
  <if_group>cms_information</if_group>
  <id>^447|449</id>
  <description>CMS User deleted event.</description>
</rule>

</group>

```

Log Inspection rule severity levels and their recommended use

Level	Description	Notes
Level 0	Ignored, no action taken	Primarily used to avoid false positives. These rules are scanned before all the others and include events with no security relevance.
Level 1	no predefined use	
Level 2	System low priority notification	System notification or status messages that have no security relevance.
Level 3	Successful or authorized events	Successful login attempts, firewall allow events, etc.
Level 4	System low priority errors	Errors related to bad configurations or unused devices or applications. They have no security relevance and are usually caused by default installations or software testing.
Level 5	User-generated errors	Missed passwords, denied actions, etc. These messages typically have no security relevance.
Level 6	Low relevance attacks	Indicate a worm or a virus that provide no threat to the system such as a Windows worm attacking a Linux server. They also include frequently triggered IDS events and common error events.
Level 7	no predefined use	
Level 8	no predefined use	
Level 9	Error from invalid	Include attempts to login as an unknown user or from an invalid source. The message might have security relevance especially if repeated. They also

Level	Description	Notes
	source	include errors regarding the admin or root account.
Level 10	Multiple user generated errors	Include multiple bad passwords, multiple failed logins, etc. They might indicate an attack, or it might be just that a user forgot his or her credentials.
Level 11	no predefined use	
Level 12	High-importance event	Include error or warning messages from the system, kernel, etc. They might indicate an attack against a specific application.
Level 13	Unusual error (high importance)	Common attack patterns such as a buffer overflow attempt, a larger than normal syslog message, or a larger than normal URL string.
Level 14	High importance security event	Typically the result of the correlation of multiple attack rules and indicative of an attack.
Level 15	Attack Successful	Very small chance of false positive. Immediate attention is necessary.

***strftime()* conversion specifiers**

Specifier	Description
%a	Abbreviated weekday name (e.g., Thu)
%A	Full weekday name (e.g., Thursday)
%b	Abbreviated month name (e.g., Aug)
%B	Full month name (e.g., August)
%c	Date and time representation (e.g., Thu Sep 22 12:23:45 2007)
%d	Day of the month (01 - 31) (e.g., 20)
%H	Hour in 24 h format (00 - 23) (e.g., 13)
%I	Hour in 12 h format (01 - 12) (e.g., 02)
%j	Day of the year (001 - 366) (e.g., 235)
%m	Month as a decimal number (01 - 12) (e.g., 02)
%M	Minute (00 - 59) (e.g., 12)
%p	AM or PM designation (e.g., AM)
%S	Second (00 - 61) (e.g., 55)
%U	Week number with the first Sunday as the first day of week one (00 - 53) (e.g., 52)
%w	Weekday as a decimal number with Sunday as 0 (0 - 6) (e.g., 2)
%W	Week number with the first Monday as the first day of week one (00 - 53) (e.g., 21)
%x	Date representation (e.g., 02/24/79)
%X	Time representation (e.g., 04:12:51)
%y	Year, last two digits (00 - 99) (e.g., 76)
%Y	Year (e.g., 2008)
%Z	Time zone name or abbreviation (e.g., EST)

Specifier	Description
%%	A % sign (e.g., %)

More information can be found at the following websites:

<https://www.php.net/manual/en/function.strftime.php>

www.cplusplus.com/reference/clibrary/ctime/

Examine a Log Inspection rule

Log Inspection rules are found in the Deep Security Manager at **Policies > Common Objects > Rules > Log Inspection Rules**.

Log Inspection rule structure and the event matching process

This screen shot displays the contents of the **Configuration** tab of the Properties window of the "Microsoft Exchange" Log Inspection rule:

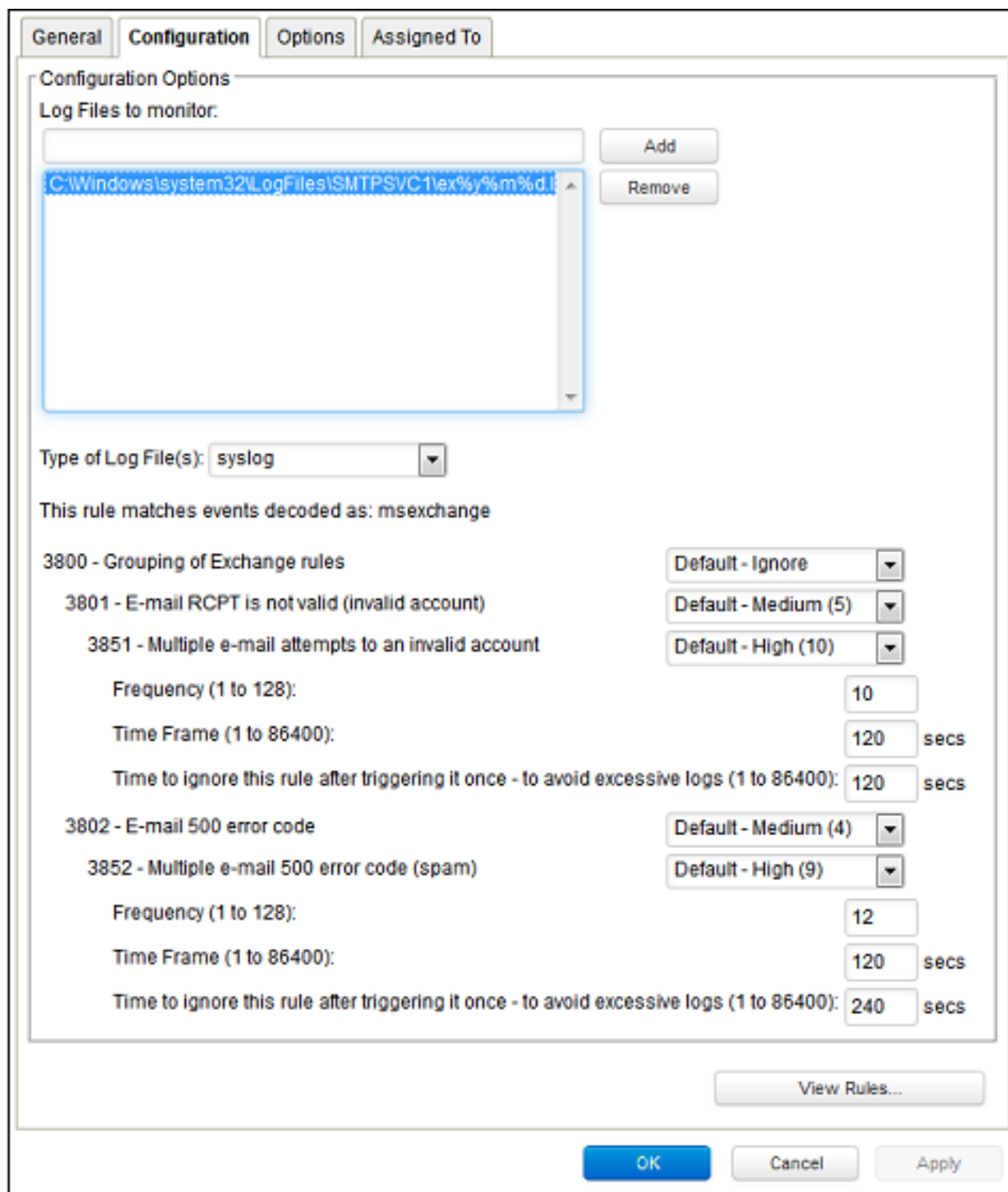

Here is the structure of the rule:

- 3800 - Grouping of Exchange Rules - Ignore
 - 3801 - Email rcpt is not valid (invalid account) - Medium (4)
 - 3851 - Multiple email attempts to an invalid account - High (9)
 - Frequency - 10
 - Time Frame - 120
 - Ignore - 120
 - 3802 - Email 500 error code - Medium (4)
 - 3852 - Email 500 error code (spam) - High (9)
 - Frequency - 12
 - Time Frame - 120
 - Ignore - 240

The Log Inspection engine will apply log events to this structure and see if a match occurs. For example, if an Exchange event occurs, and this event is an email receipt to an invalid account, the event will match line 3800 (because it is an Exchange event). The event will then be applied to line 3800's sub-rules: 3801 and 3802.

If there is no further match, this "cascade" of matches will stop at 3800. Because 3800 has a severity level of "Ignore", no Log Inspection event would be recorded.

However, an email receipt to an invalid account does match one of 3800's sub-rules: sub-rule 3801. Sub-rule 3801 has a severity level of "Medium(4)". If the matching stopped here, a Log Inspection event with a severity level of "Medium(4)" would be recorded.

But there is still another sub-rule to be applied to the event: sub-rule 3851. Sub-rule 3851 with its three attributes will match if the same event has occurred 10 times within the last 120 seconds. If so, a Log Inspection event with a severity "High(9)" is recorded. (The "Ignore" attribute tells sub-rule 3851 to ignore individual events that match sub-rule 3801 for the next 120 seconds. This is useful for reducing "noise".)

Assuming the parameters of sub-rule 3851 have been matched, a Log Inspection event with Severity "High(9)" is now recorded.

Looking at the Options tab of the Microsoft Exchange Rule, we see that Deep Security Manager will raise an alert if any sub-rules with a severity level of "Medium(4)" have been matched. Since this is the case in our example, the alert will be raised (if "Alert when this rule logs an event" is selected).

Duplicate Sub-rules

Some Log Inspection rules have duplicate sub-rules. To see an example, open the "Microsoft Windows Events" rule and click on the **Configuration** tab. Note that sub-rule 18125 (Remote access login failure) appears under sub-rules 18102 and 18103. Also note that in both cases sub-rule 18125 does not have a severity value, it only says "See Below".

Instead of being listed twice, Rule 18125 is listed once at the bottom of the **Configuration** page:

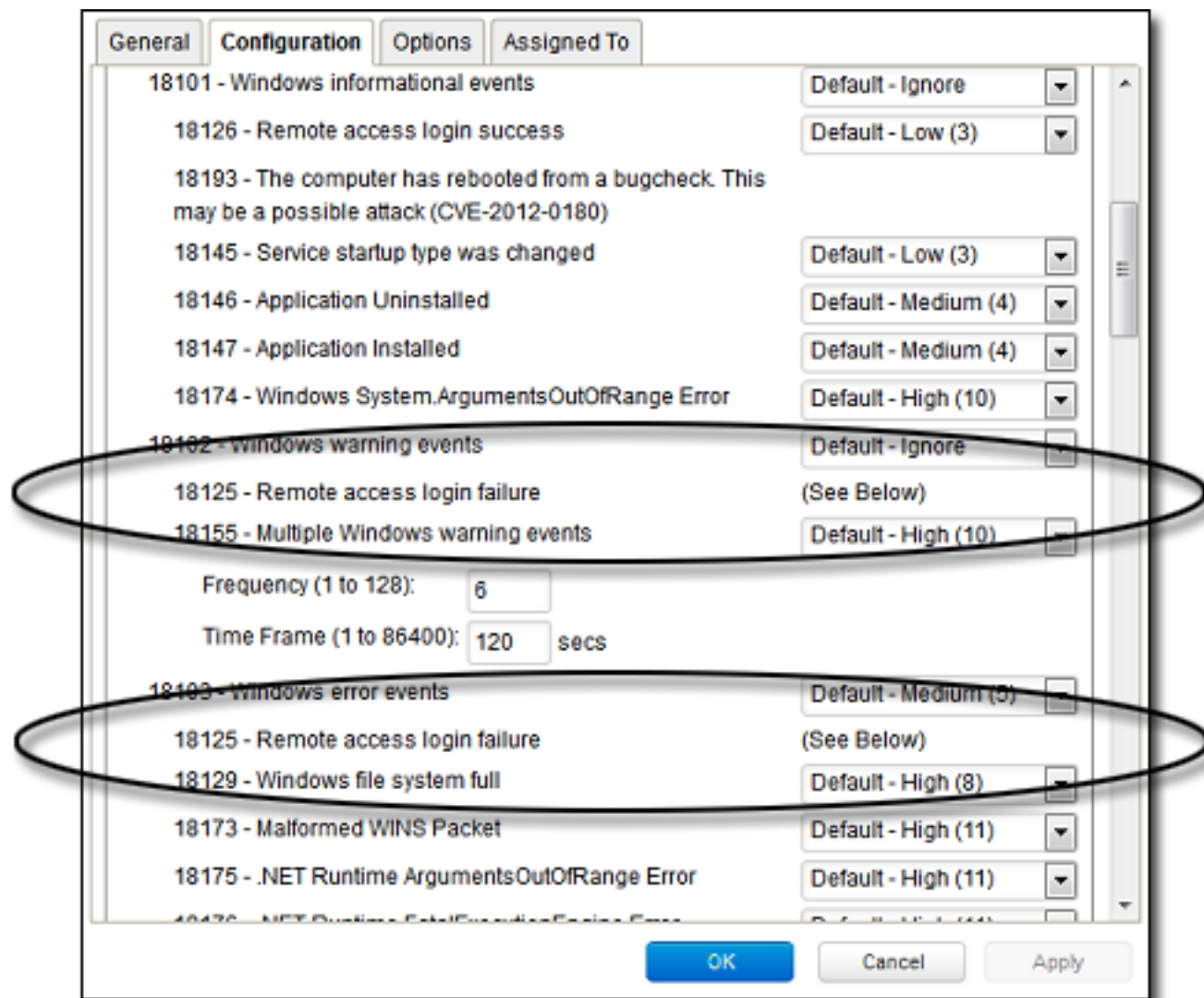

Configure Application Control

About Application Control

Note: You can enable application control for computers running Deep Security Agent 10.0 or higher. For a list of operating systems where application control is supported, see "[Supported features by platform](#)" on page 360.

Application control continuously monitors for software changes on your protected servers. Based on your policy configuration, application control either prevents unauthorized software from running until it is explicitly allowed, or allows unauthorized software until it is explicitly blocked. Which option you choose depends on the level of control you want over your environment.

Warning: Application control continuously monitors your server and logs an event whenever a software change occurs. It is not intended for environments with self-changing software or that normally creates executables, such as some web or mail servers. To ensure Application Control is appropriate for your environment, check "[What does application control detect as a software change?](#)" on page 1074.

Tip: You can automate Application Control creation and configuration using the Deep Security API. For more information, see the [Configure Application Control](#) guide in the Deep Security Automation Center.

Key concepts

Targeted protection state: One of the main decisions you need to make when setting up application control is deciding your targeted protection state. Do you want to prevent all new or changed software from running, unless you manually specify that it is allowed? Or do you want it to run by default unless you specifically block it? One approach is to initially allow unrecognized software to run when you first enable application control and there's a lot of unrecognized software. As you add application control rules and the volume of unrecognized software decreases, you could switch to block mode.

Application control rule: Rules specify whether software is allowed or blocked on a particular computer.

Inventory: Initial list of software that is installed on the computer and allowed to run. Make sure only software that you want to allow is installed on the computer. When you enable application

control, all currently installed software is added to the computer's inventory and allowed to run. When a computer is in maintenance mode, any software changes made to the computer are added to the computer's inventory and allowed to run. A computer's software inventory is stored on the Deep Security Agent and is not displayed in Deep Security Manager.

Unrecognized software: Software that isn't in a computer's inventory and isn't already covered by an application control rule. See ["What does application control detect as a software change?" on page 1074](#)

Maintenance mode: If you are planning to install or update software, we strongly advise that you turn on maintenance mode. In maintenance mode, application control continues to block software that is specifically blocked by an Application Control rule, but allows new or updated software to run and adds it to the computer's inventory. See ["Turn on maintenance mode when making planned changes" on page 1080](#).

Note: To improve overall system security, the inventory does not include software on remote file systems, and maintenance mode does not automatically allow new or updated software from remote file systems. Software on remote file systems must be added to the inventory manually.

How does application control work?

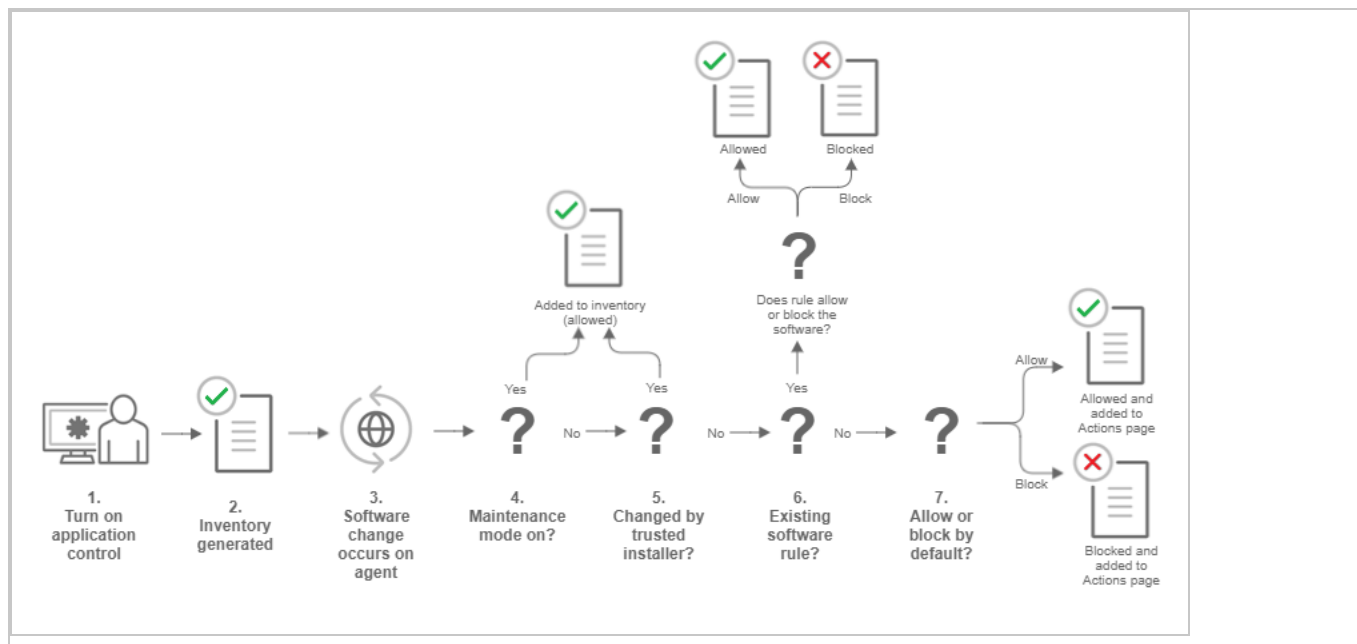

1. You enable application control in a policy and assign the policy to a computer that is protected by a Deep Security Agent (see ["Turn on Application Control" on page 1076](#)).

2. When the agent receives the policy, it creates an inventory of all software installed on the computer. All software listed in the inventory is assumed to be safe and is allowed to run on that computer. This inventory list is not visible from Deep Security Manager, which means you need to be absolutely certain that only good software is installed on a computer where you intend to enable application control.
3. After the inventory is finished, application control is aware of any software changes on the computer. A software change could be new software that appears on the computer or changes to existing software.
4. If the computer is in maintenance mode, the Deep Security Agent adds the software to its inventory list and it is allowed to run. This change is not visible in Deep Security Manager. See ["Turn on maintenance mode when making planned changes" on page 1080](#).
5. If the change was made by a trusted installer, the Deep Security Agent adds the software to its inventory list and allows it to run. For example, when Microsoft Windows self-initiates a component update, hundreds of new executable files may be installed. Application control auto-authorizes many file changes that are created by well-known Windows processes and does not list these changes in Deep Security Manager. Removing the "noise" associated with expected software changes provides you with clearer visibility into changes that may need your attention.

Note: The trusted installer feature is available with Deep Security Agent 10.2 or later.

6. If the computer's ruleset contains a rule for this exact piece of software, the software is allowed or blocked according to the rule that's in place. See ["What does application control detect as a software change?" on page 1074](#)
7. If software is not in the computer's inventory and is not covered by an existing rule, it's considered unrecognized software. The policy assigned to the computer specifies how unrecognized software is handled. Depending on the policy configuration, it's either allowed to run or is blocked. If the software is blocked and it is able to produce error messages in the OS, an error message on the protected computer indicates that the software does not have permissions to run or that access is denied.

The unrecognized software appears on the **Application Control - Software Changes** page in Deep Security Manager. On that page, an administrator can click **Allow** or **Block** to create an allow or block rule for that piece of software on a particular computer. An allow or block rule takes precedence over the default action specified in the policy. See ["Monitor new and changed software" on page 1077](#).

A tour of the application control interface

There are a few places in Deep Security Manager where you can see changes related to application control:

- "Application Control: Software Changes (Actions)" below
- "Application Control Rulesets" on the next page
- "Security Events" on page 1074

Application Control: Software Changes (Actions)

The screenshot shows the 'Application Control: Software Changes' page in the Trend Micro Deep Security Manager. The interface includes a navigation sidebar on the left with options like 'Smart Folders', 'Agent Software Status', 'Corporate Laptops', 'docker', 'Linux box', 'Windows 10 Computer(s)', 'Windows 32 bit Computer(s)', 'Windows Application Control', and 'Computers' (12,876). The main content area features a title 'Application Control: Software Changes' with a 'Last 7 Days' filter. Below the title is a search bar and a bar chart showing the number of software changes per day from Friday, Feb 09 to Friday, Feb 16. The chart shows a significant spike on Monday, Feb 12. Below the chart, it states '12876 occurrence(s) of software changes' and provides a 'Group By File (Hash)' dropdown. A table lists software items, with the first item 'agent-core-windows-10.1.0-357.x86_64...' selected, showing 84 occurrences and 'ALLOW ALL' and 'BLOCK ALL' buttons. Below the table, it says '5 out of 84 Show More'. The right sidebar displays details for the selected software, including Product Name (Not Detected), File Name (agent-core-windows-10.1.0-357.x86_64.msi), Install Path (c:\program files\trend micro\deep security manager\temp\agent-windows-10.1.0-357.x86_64\), Vendor (Not Detected), File Size (13 MB), File Version (Not Detected), Description (Not Detected), SHA256 (3A5443C69F8AD2611210E4FD83BE93E3E76FB99700EE12BF0C3E390E6B499304), SHA1 (AB07FE450A4544C80CEDFC17AF1F59D6B D24B202), and MD5 (02150914CD0A1C01030B65E88840BC6F).

The **Application Control: Software Changes** page is displayed when you click **Actions** in Deep Security Manager. It displays all unrecognized software (software that isn't in a computer's inventory and doesn't have a corresponding application control rule). Software changes are allowed or blocked at the computer level, so if a particular piece of software is installed on fifty computers, it will appear on that page fifty times. However, if you know that a certain piece of software should be allowed or blocked everywhere, you can filter the **Actions** page to sort the changes by file hash and then click **Allow All** to allow it on all computers where the software is installed.

The policy applied to a computer specifies whether it will allow all unrecognized software to run by default, or block all unrecognized software, but no explicit application control rule is created until you click "Allow" or "Block" on the Actions page. When you click Allow or Block, a corresponding rule appears in the ruleset for the computer. The rulesets are displayed on the **Application Control Rulesets** page.

Application Control Rulesets

NAME	CREATED	LAST UPDATED
Local (2)		
[Icon] [Redacted]	October 18, 2016 15:03	October 18, 2016 15:03
[Icon] [Redacted]	October 18, 2016 13:32	October 18, 2016 14:12
Shared (15)		
[Icon] ActionableEventsSecurityEvent...	October 18, 2016 14:04	October 18, 2016 14:05
[Icon] ActionableEventsSecurityEvent...	October 18, 2016 14:06	October 18, 2016 14:07
[Icon] ActionableEventsSecurityEvent...	October 18, 2016 14:09	October 18, 2016 14:09
[Icon] ActionableEventsSecurityEvent...	October 18, 2016 14:05	October 18, 2016 14:06
[Icon] ActionableEventsSecurityEvent...	October 18, 2016 14:08	October 18, 2016 14:08
[Icon] inventoryName1476811733	October 18, 2016 13:31	October 18, 2016 13:31

To see the ruleset for a computer, go to **Policies > Common Objects > Rules > Application Control Rulesets**. To see which rules are part of a ruleset, double-click the ruleset and go to the **Rules** tab. The Rules tab displays the pieces of software that have rules associated with them and enables you to change allow rules to block, and vice versa.

Security Events

The screenshot shows the 'Events & Reports' section of the Trend Micro Deep Security console. The 'Application Control Events' page is active, displaying a list of events. The table below summarizes the visible data:

TIME	COMPUTER	EVENT	RULES	RULESET
February 16, 2018 12:4...	...	Execution of Unrecognized Software Allowed	View rules...	None
February 16, 2018 12:3...	(...	Execution of Unrecognized Software Allowed	View rules...	None
February 16, 2018 12:3...	...	Execution of Unrecognized Software Allowed	View rules...	None
February 16, 2018 12:3...	...	Execution of Unrecognized Software Allowed	View rules...	None
February 16, 2018 12:3...	...	Execution of Unrecognized Software Allowed	View rules...	None
February 16, 2018 12:3...	...	Execution of Unrecognized Software Allowed	View rules...	None

Events & Reports > Events > Application Control Events > Security Events displays all unrecognized software that either has been run on a computer or has been prevented from running by a block rule. You can filter this list by time period and other criteria.

For each event (except aggregated events), you can click **View rules** to change the rule from Allow to Block or vice versa. Deep Security Agent 10.2 or later includes event aggregation logic to reduce the volume of logs when the same event occurs repeatedly.

What does application control detect as a software change?

Unlike [integrity monitoring](#), which monitors any file, application control looks only for software files when examining the initial installation and monitoring for change.

Software can be:

- Windows applications (.exe, .com, .dll, .sys), Linux libraries (.so) and other compiled binaries and libraries
- Java .jar and .class files, and other compiled byte code
- PHP, Python, and shell scripts, and other web apps and scripts that are interpreted or compiled on the fly
- Windows PowerShell scripts, batch files (.bat), and other Windows-specific scripts (.wsf, .vbs, .js)

For example, WordPress and its plug-ins, Apache, IIS, nginx, Adobe Acrobat, app.war, and /usr/bin/ssh would all be detected as software.

Application control checks a file's extension to determine whether it's a script. Additionally, on Linux, application control treats any file with execute permissions as if it's a script.

Note: On Windows computers, application control tracks changes on the local file system, but not on network locations, CD or DVD drives, or USB devices.

Application control is integrated with the kernel (on Linux computers) and file system, so it has permissions to monitor the whole computer, including software installed by root or administrator accounts. The agent watches for disk write activity on software files, and for attempts to execute software.

Differences in how Deep Security Agent 10 and 11 compare files

To determine whether software is new or has changed, Deep Security 10 agents compare the file with the initially installed software's SHA-256 hash, file size, path, and file name (they have a "file-based" ruleset). Deep Security 11 (and newer) agents compare only the file's SHA-256 hash and file size (they have a "hash-based" ruleset). Because the rules created by Deep Security 11 (and newer) agents compare only the unique hash and file size, a rule will continue to be applied even if the software file is renamed or moved. As a result, using Deep Security 11 (and newer) agents reduces the number of software changes that you need to deal with.

A Deep Security 10 agent continues to use a file-based ruleset until it is upgraded to Deep Security 11.0 or newer. When you upgrade an agent to version 11.0 or newer, its ruleset is converted to use hash-based rules. If there are multiple file-based rules for the same hash value, they are consolidated into one hash-based rule. If the rules being consolidated conflict with each other (one rule blocks the file and another allows it), the new hash-based rule will be an "allow" rule.

Set up Application Control

Warning: Application Control continuously monitors your server and logs an event whenever a software change occurs. It is not intended for environments with self-changing software or that normally creates executables, such as some web or mail servers. To ensure Application Control is appropriate for your environment, check ["What does application control detect as a software change?" on the previous page.](#)

For information about how Application Control works, see ["About Application Control"](#) on [page 1069](#).

To enable Application Control and monitor software changes:

1. ["Turn on Application Control" below](#)
2. ["Monitor new and changed software" on the next page](#)
3. ["Turn on maintenance mode when making planned changes" on page 1080](#)

This article also provides ["Application Control tips and considerations" on page 1081](#) that you should be aware of when working with Application Control.

Once you've enabled Application Control, you can also learn how to:

- ["View and change Application Control rulesets" on page 1086](#)
- ["Reset Application Control after too much software change" on page 1118](#)
- ["Monitor Application Control events" on page 1083](#)
- ["Use the API to create shared and global rulesets" on page 1119](#)

Turn on Application Control

You can enable Application Control in the settings for a computer or in policies:

1. Open the Computer or Policy editor and go to **Application Control > General**.
2. Set the **Application Control State** to "On" or "Inherited (On)".
3. Under **Enforcement**, select your targeted protection state:
 - **Block unrecognized software until it is explicitly allowed**
 - **Allow unrecognized software until it is explicitly blocked** (we recommend that you choose this option when initially setting up Application Control)
4. Click **Save**.

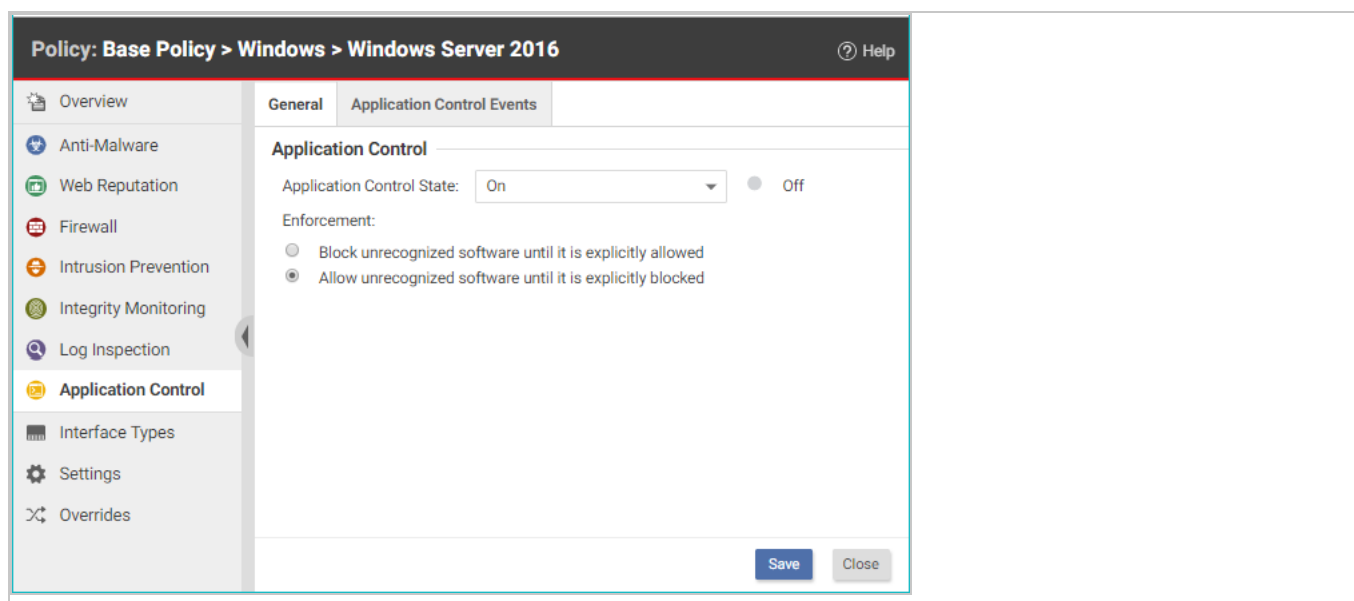

The next time that the Deep Security Manager and agent connect, the agent scans and then generates an inventory of all software installed on the computer and creates rules that allow all the software that it finds. This initial inventory can take 15 minutes or longer, depending on your environment.

Warning: When generating an inventory, Application Control does not include software on remote file systems such as a CIFS (Common Internet File System) or NFS (Network File System). Software on remote file systems must be manually added to the inventory.

To check that Application Control is working as expected, follow the instructions in ["Verify that Application Control is enabled"](#) on page 1082.

Monitor new and changed software

Once an inventory has been created on a protected computer, any software executable files that are added or changed are classified as a "software change" and appear on the **Actions** page in Deep Security Manager. When unrecognized software runs, or attempts to run and is blocked, the event is listed under **Events & Reports > Events > Application Control Events > Security Events**. For more information, see ["Application Control events"](#) on page 1349

After you initially enable Application Control, you will likely see a lot of software changes on the **Actions** page. This can happen when allowed software creates new executables, renames files, or relocates files through the normal course of operation. As you add rules to tune Application Control, you should see fewer software changes.

To quickly find all software changes on all computers and easily create allow or block rules for them, use the **Actions** tab.

Tip: You can automate the creation of allow or block rules using the Deep Security API. For more information, see the [Allow or block unrecognized software](#) guide in the Deep Security Automation Center.

1. In Deep Security Manager, go to **Actions**.
2. There are several ways you can filter to see only specific occurrences of unrecognized software.

Tip: Instead of evaluating each software change on each computer individually, use the filters described below to find software changes that you know are good, and allow them in bulk.

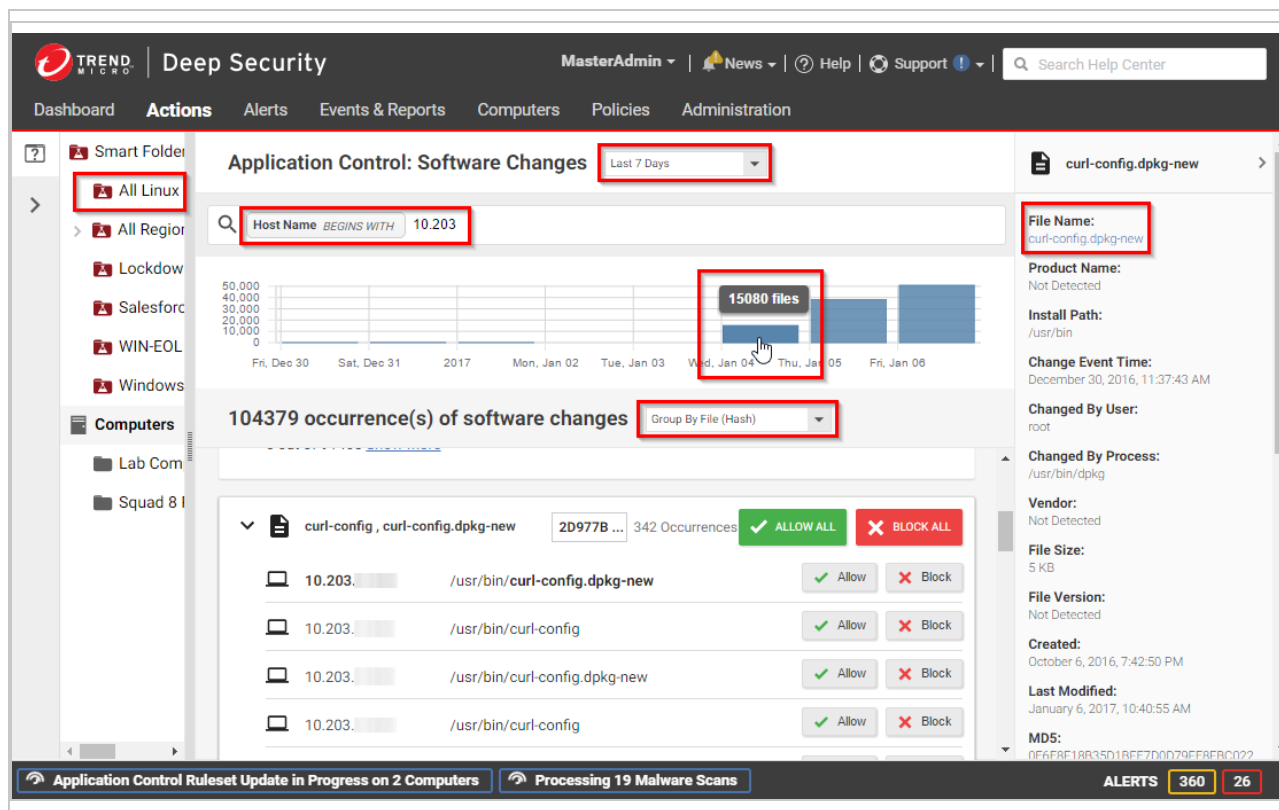

To reduce the number of software changes being displayed:

- From the drop-down list next to **Application Control: Software Changes**, select a time range such as **Last 7 Days**. You can also click a bar in the graph near the top of the page to display the changes for that time period.

- In the pane on the left, click **Computers** and select an individual computer or group, or click **Smart Folders** to display only the computers that are included in a particular smart folder (see "[Group computers dynamically with smart folders](#)" on page 1542).

Note: Unlike the **Computers** tab, the **Software Changes** pane usually does not show all computers. It only displays computers where Application Control has detected software changes that don't already have allow or block rules.

- Enter search terms and operators in the search filter field. You search for these attributes: Change By Process, Change By User, File Name, Host Name, Install Path, MD5, SHA1, and SHA256. For example, you could find all changes made by a particular user that you trust and click **Allow All** to allow all of their changes. Or if a particular software update was installed across your organization (while [maintenance mode](#) was not enabled), filter the page according to the hash value of the file and click **Allow All** to allow all occurrences.

Tip: Details about a software change are displayed in the right pane. You can click the file name or computer name in the details to add it to your search filter.

- Select whether to **Group by File (Hash)** or **Group by Computer**.
3. Click either **Allow** or **Block** to add an allow or block rule on that computer, for that software. If you need more information to decide whether to allow or block, click the software name, then use the details panel on the right side.

The next time that the agent connects with the Deep Security Manager, it receives the new rules.

Tips for handling changes

- For most environments, we suggest that you select the **Allow unrecognized software until it is explicitly blocked** option to allow software changes by default when you first enable Application Control and add allow and block rules for changes that you see on the **Actions** page. Eventually, the rate of software changes should decrease. At that point, you could consider blocking software changes by default and creating allow rules for the software that you know is good. Some organizations prefer to continue to allow changes by default and monitor the **Actions** page for software that should be blocked.
- You may prefer to start by evaluating security events, rather than dealing with unrecognized software first. Security events show you which unrecognized software has run (or attempted to run). For information on security events, see "[Monitor Application Control events](#)" on page 1083.

- When an unrecognized file is allowed to execute and you want to continue to allow it, create an Allow rule. In addition to allowing the file's execution, the event is no longer logged for that file, which reduces noise and makes important events easier to find.
- When a known file's execution is blocked, consider cleaning that file from the computer, especially for repeated occurrences.
- Keep in mind that software changes are listed for each computer where they occur. You must allow or block the software for each computer.
- Rules are assigned to computers, not to policies. For example, if `helloworld.py` is detected on three computers, when you click **Allow All** or **Block All**, this would affect only three computers. It won't affect future detections on other computers, because they have their own rulesets.
- If you see changes related to software updates that you can control, use the maintenance mode feature when performing those updates. See ["Turn on maintenance mode when making planned changes" below](#).

Turn on maintenance mode when making planned changes

Warning: With maintenance mode enabled, Application Control does not scan remote file systems such as a CIFS (Common Internet File System) or NFS (Network File System). Since software changes on remote file systems cannot be auto-authorized, we recommended that you manually add them to the software inventory as required.

When you install patches, upgrade software, or deploy web applications, Application Control will detect them. Depending on your setting for how to handle unrecognized software, this could block that software until you use the **Actions** tab to create allow rules.

To avoid extra down time and alerts during deployment and maintenance windows, you can put Application Control into a mode designed for maintenance windows. While maintenance mode is enabled, Application Control will continue to enforce rules that block software, but it will allow new or updated software to run and automatically add it to the computer's inventory.

Tip: You can automate maintenance mode using the Deep Security API. For more information, see the [Configure maintenance mode during upgrades](#) guide in the Deep Security Automation Center.

1. In Deep Security Manager, go to **Computers**.
2. Select one or more computers, then click **Actions > Turn On Maintenance Mode**.

3. Select the duration of your maintenance window.

Maintenance mode will automatically disable itself when your maintenance window is scheduled to end. Alternatively, if you'd prefer to manually disable maintenance mode when updates are finished, select **Indefinite**.

On the **Dashboard**, the **Application Control Maintenance Mode Status** widget indicates whether the command succeeded.

4. Install or upgrade software.
5. If you chose to disable maintenance mode manually, remember to disable maintenance mode in order to start to detect software changes again.

Application Control tips and considerations

- For better performance with Application Control, use Deep Security anti-malware instead of Windows Defender. See ["Coexistence of Deep Security Agent with Microsoft Defender Antivirus" on page 827](#).
- If you create a block rule for a batch file or PowerShell script, you will not be able to copy, move, or rename the file when using its associated interpreter (powershell.exe for PowerShell scripts or cmd.exe for batch files).
- If you add an allow or block rule, it is normally sent to the agent the next time the agent connects to Deep Security Manager. If you see an error saying that the ruleset upload was not successful, verify that network devices between the agent and the manager or relay allow communications on the heartbeat port number or relay [port numbers](#).
- To verify that a block rule is working, try to run the software that you just blocked. (For details on how Deep Security Agent detects changes, see ["What does application control detect as a software change?" on page 1074](#))
- When blocked software remains installed, Application Control continues to record logs and show alerts when it blocks the software from running. To reduce the permission error logs on the computer and also reduce your attack surface, uninstall the software that Application Control is blocking. Once that is done, if you want to dismiss related alerts, either go to **Alerts** or go to **Dashboard**, click the alert, and then click **Dismiss Alert**. Not all alerts can be dismissed. For more information, see ["Predefined alerts" on page 1274](#).
- For performance reasons, if the computer has too much software change, Application Control will continue to enforce existing rules, but stop detecting and displaying software changes. To resolve this, see ["Reset Application Control after too much software change" on page 1118](#).

Verify that Application Control is enabled

For an overview of Application Control, see ["About Application Control" on page 1069](#). For initial configuration instructions, see ["Set up Application Control" on page 1075](#).

When Application Control is enabled and has finished its initial software inventory scan:

- The **State** field indicates "On" or "On, Blocking unrecognized software".
- On **Computers**, the **Status** field changes from "Application Control Ruleset Build In Progress" to "Managed (Online)".
- **Events & Reports > Events > System Events** will record "Application Control Ruleset Build Started" and "Application Control Ruleset Build Completed". (If you don't see any logs, see ["Choose which Application Control events to log" on page 1084](#).)

The screenshot displays the 'Computer' configuration page in the Trend Micro Deep Security console. The left sidebar shows various security modules, with 'Application Control' highlighted. The main content area is divided into 'General' and 'Agent' sections. The 'Agent' section shows the status of various security modules, with 'Application Control' set to 'On' and highlighted by a red box. Below the 'Agent' section, there are buttons for 'Check Status' and 'Clear Warnings/Errors'. At the bottom right, there are 'Save' and 'Close' buttons.

Module	Status
Anti-Malware	Managed (Online)
Web Reputation	On, Real Time
Firewall	On
Intrusion Prevention	On, 16 rules
Intrusion Prevention	On, Prevent, 113 rules
Integrity Monitoring	On, 27 rules
Log Inspection	On, 7 rules
Application Control	On
Online	Yes
Last Communication	January 6, 2017 14:20

To verify that Application Control is working:

1. Copy an executable to the computer or add execute permissions to a plain text file. Try to run the executable.

Depending on your enforcement setting for unrecognized software, it should be either blocked or allowed. Once Application Control has built initial allow rules or downloaded a shared ruleset, if any change is detected, it should appear in the **Actions** tab, which you can use to create allow and block rules (see "[Monitor new and changed software](#)" on [page 1077](#)). Depending on your alert configuration, you will also see an alert if unrecognized software is detected, or if Application Control blocks software from launching (see "[Monitor Application Control events](#)" below). The event should persist until the software change no longer exists, or until the oldest data has been removed from the database.

2. Add an allow or block rule for your test software and then try again. This time, Application Control should apply your allow or block rule.

Tip: If software is accidentally blocked because you've selected **Block unrecognized software until it is explicitly allowed** and the software isn't being recognized, the **Reason** column in Application Control event logs can help you to troubleshoot the cause.

Monitor Application Control events

For an overview of Application Control, see "[About Application Control](#)" on [page 1069](#). For initial configuration instructions, see "[Set up Application Control](#)" on [page 1075](#).

By default, when you enable Application Control it logs events, such as when there are software changes or when it blocks software from executing. Application Control events appear on the **Actions** and **Events & Reports** pages. If configured, an alert appears on the **Alerts** page.

You can configure some of which Application Control event logs are recorded, and which are [forwarded to external SIEM systems, or syslog servers](#).

To monitor for software changes on computers:

1. "[Choose which Application Control events to log](#)" on the next page
2. "[View Application Control event logs](#)" on the next page
3. "[Interpret aggregated security events](#)" on the next page
4. "[Monitor Application Control alerts](#)" on [page 1085](#)

Choose which Application Control events to log

1. Go to **Administration > System Settings > System Events**.
2. Scroll down to the Application Control events such as Event ID 7000 "Application Control Events Exported".
3. If you want to record event logs for that type of event, select **Record**.

When those events occur, they appear on **Events & Reports > Events > System Events**. Logs are kept until they meet maximum log age criteria. For details, see "[About Deep Security event logging](#)" on page 1125.

Note: Events that appear on **Computers > Details > Application Control > Events** are not configured here. They are always logged.

4. If you want to forward event logs to a SIEM, or syslog server, select **Forward**.
5. If you use an external SIEM, you may need to load the list of possible Application Control event logs, and indicate what action to take. For a list of Application Control events, see "[System events](#)" on page 1298 and "[Application Control events](#)" on page 1349.

View Application Control event logs

Application Control generates system events and security events:

- **System event:** An audit event that provides a history of configuration changes or software updates. To see system events click **Events & Reports > Events > System Events**. For a list, see "[System events](#)" on page 1298.
- **Security event:** An event that occurs on the agent when Application Control blocks or allows unrecognized software, or blocks software due to a block rule. To see security events, click **Events & Reports > Events > Application Control Events > Security Events**. For a list, see "[Application Control events](#)" on page 1349.

Interpret aggregated security events

When an agent heartbeat includes several instances of the same security event, Deep Security aggregates the events in the Security Events log. Event aggregation reduces the number of items in the log, making it easier to find important events:

- When the event occurs for the same file, which is usually the case, the log includes the file name with the aggregated event. For example, a heartbeat includes 3 instances of the "Execution of Unrecognized Software Allowed" event for the Test_6_file.sh file, and no

other instances of that event. Deep Security aggregates these 3 events for the file Test_6_file.sh.

- When the event occurs for many files, the log omits the rules link, path, file name, and user name. For example, a heartbeat includes 21 instances of the "Execution of Unrecognized Software Allowed" event that occurred for several different files. Deep Security aggregates the 21 events in a single event, but does not include a rules link, path, file name, or user name.

When aggregated events apply to multiple files, other occurrences of these events have likely been reported in other heartbeats. After you respond to other events where the file name is known, it is likely that no more aggregated events occur.

In the log, aggregated events use special icons, and the **Repeat Count** column indicates the number of events that are aggregated.

Application Control Events									
All		No Grouping		Search this page					
Period: Last 7 Days									
Computers: All Computers									
View Export Auto-Tagging... Columns...									
TIME	COMPUTER	EVENT	RULES	RULESET	REPEAT COUNT	ACTION	REASON	FILE	
October 6, 2017 10:31:...		Execution of Unrecognized Software Allowed	Change rules...	None	1	Allowed	N/A	Test_4_file.sh	
October 6, 2017 10:30:...		Execution of Unrecognized Software Allowed	Change rules...	None	1	Allowed	N/A	Test_3_file.sh	
October 6, 2017 10:31:...		Execution of Unrecognized Software Allowed	Change rules...	None	2	Allowed	N/A	Test_1_file.sh	
October 6, 2017 10:30:...		Execution of Unrecognized Software Allowed	Change rules...	None	2	Allowed	N/A	Test_9_file.sh	
October 6, 2017 10:31:...		Execution of Unrecognized Software Allowed	Change rules...	None	2	Allowed	N/A	Test_5_file.sh	
October 6, 2017 10:31:...		Execution of Unrecognized Software Allowed	Change rules...	None	3	Allowed	N/A	Test_6_file.sh	
October 6, 2017 10:30:...		Execution of Unrecognized Software Allowed	Change rules...	None	1	Allowed	N/A	heartbeatSyn...	
October 5, 2017 15:04:...		Execution of Unrecognized Software Allowed	Change rules...	None	1	Allowed	N/A	Test_7_file.sh	
October 5, 2017 15:04:...		Execution of Unrecognized Software Allowed	Change rules...	None	1	Allowed	N/A	Test_3_file.sh	
October 5, 2017 15:04:...		Execution of Unrecognized Software Allowed	Change rules...	None	1	Allowed	N/A	Test_5_file.sh	
October 5, 2017 15:04:...		Execution of Unrecognized Software Allowed	Change rules...	None	1	Allowed	N/A	heartbeatSyn...	
October 5, 2017 14:42:...		Execution of Unrecognized Software Allowed	N/A	None	21	Allowed	N/A	N/A	

Monitor Application Control alerts

To configure which Application Control events or severity levels cause an alert, go to the **Alerts** tab, click the **Configure Alerts** button, and then select an event and double-click **Properties**. For details, see "[Configure alerts](#)" on page 1263.

When alerts are enabled for Application Control events, any software change that the Application Control engine detects and any software that it blocks from executing appear in the

Alerts tab. If you have enabled the **Alert Status** widget, Application Control alerts also appear on the Dashboard.

The screenshot shows the Trend Micro Deep Security dashboard. The top navigation bar includes the logo, 'Deep Security', and user information 'MasterAdmin'. Below the navigation bar, there are tabs for 'Dashboard', 'Actions', 'Alerts', 'Events & Reports', 'Computers', 'Policies', and 'Administration'. The 'Alerts' tab is selected. The dashboard displays several widgets: 'Alert Status' (showing 0 Critical and 3 Warning alerts), 'Computer Status' (a pie chart showing 1 Managed and 2 Unmanaged computers), and 'My User Summary' (showing the user 'MasterAdmin' with Full Access). The 'Alert Status' widget is highlighted with a red box, and a mouse cursor is pointing at the 'Execution of Software Blocked' alert.

LATEST ALERTS:		AGE
Warning	Software Changes Detected	19 Hou...
Warning	Execution of Software Blocked - ...	20 Hou...
Warning	New Rule Update is Downloaded ...	April 2...

To monitor which computers are in maintenance mode, you can also click **Add/Remove Widgets** and enable the **Application Control Maintenance Mode** widget, which displays a list of the computers and their scheduled maintenance windows.

View and change Application Control rulesets

Each computer has its own Application Control ruleset. You can:

- ["View Application Control rulesets" on the next page](#) and find out which rules they include.

Tip: When you first enable Application Control for a computer, the software installed on the computer is added to the computer's inventory and allowed to run. However, you cannot see the rules associated with the inventory from Deep Security Manager unless you use the Deep Security legacy REST API to do so (see ["Use the API to create shared and global rulesets" on page 1119](#)). In Deep Security Manager, a computer's ruleset appears empty until you create some allow/block rules for the computer.

- ["Change the action for an Application Control rule" on the next page](#) if a software file should no longer be allowed/blocked.
- ["Delete an individual Application Control rule" on page 1089](#) if the software has been removed and isn't likely to return.
- ["Delete an Application Control ruleset" on page 1090](#) if the computer associated with the ruleset has been removed.

Tip: If a user reports that Application Control is blocking software that they need to run on a particular computer, you can undo the block rule on that computer. Go to **Events & Reports > Application Control Events > Security Events**, find the computer, locate the block event, and then click **View Rules**. In the pop-up that appears, you can change the block rule to an allow rule.

View Application Control rulesets

To view the list of Application Control rulesets, go to **Policies > Common Objects > Rules > Application Control Rulesets**.

The screenshot shows the 'Application Control Rulesets' page in the Trend Micro Deep Security console. The page has a navigation bar at the top with tabs for Dashboard, Actions, Alerts, Events & Reports, Computers, Policies, and Administration. The 'Policies' tab is selected. On the left, there is a sidebar with a tree view showing 'Policies' > 'Common Objects' > 'Rules' > 'Application Control Rulesets'. The main content area shows a table of rulesets. The table has columns for 'NAME', 'CREATED', and 'LAST UPDATED'. The rulesets are grouped into 'Local (2)' and 'Shared (15)'. The 'Local' rulesets are: 'Local (2)' with two entries. The 'Shared' rulesets are: 'ActionableEventsSecurityEvent...' (6 entries) and 'inventoryName1476811733' (1 entry).

NAME	CREATED	LAST UPDATED
Local (2)		
[Redacted]	October 18, 2016 15:03	October 18, 2016 15:03
[Redacted]	October 18, 2016 13:32	October 18, 2016 14:12
Shared (15)		
ActionableEventsSecurityEvent...	October 18, 2016 14:04	October 18, 2016 14:05
ActionableEventsSecurityEvent...	October 18, 2016 14:06	October 18, 2016 14:07
ActionableEventsSecurityEvent...	October 18, 2016 14:09	October 18, 2016 14:09
ActionableEventsSecurityEvent...	October 18, 2016 14:05	October 18, 2016 14:06
ActionableEventsSecurityEvent...	October 18, 2016 14:08	October 18, 2016 14:08
inventoryName1476811733	October 18, 2016 13:31	October 18, 2016 13:31

To see which rules are part of a ruleset, double-click the ruleset and go to the **Rules** tab. The Rules tab displays the software files that have rules associated with them and enables you to

change allow rules to block, and vice versa. (See ["Change the action for an Application Control rule" below](#).)

Security Events

The screenshot shows the 'Events & Reports' section of the Trend Micro Deep Security console. The main view is 'Application Control Events', filtered to 'All' and 'No Grouping'. The period is set to 'Last Hour' and the scope is 'All Computers'. The table below shows several events:

TIME	COMPUTER	EVENT	RULES	RULESET
February 16, 2018 12:4...	...	Execution of Unrecognized Software Allowed	View rules...	None
February 16, 2018 12:3...	(...)	Execution of Unrecognized Software Allowed	View rules...	None
February 16, 2018 12:3...	...	Execution of Unrecognized Software Allowed	View rules...	None
February 16, 2018 12:3...	...	Execution of Unrecognized Software Allowed	View rules...	None
February 16, 2018 12:3...	...	Execution of Unrecognized Software Allowed	View rules...	None
February 16, 2018 12:3...	...	Execution of Unrecognized Software Allowed	View rules...	None

Events & Reports > Events > Application Control Events > Security Events displays all unrecognized software that either was run on a computer or was actively blocked from running. You can filter this list by time period and other criteria. For more information, see ["Application Control events" on page 1349](#).

For each event (except aggregated events), you can click **View rules** to change the rule from Allow to Block or vice versa.

Deep Security Agent 10.2 or later includes event aggregation logic to reduce the volume of logs when the same event occurs repeatedly. (See ["Interpret aggregated security events" on page 1084](#).)

Change the action for an Application Control rule

If you want to allow a software that you previously blocked (or the opposite), you can edit the action in the rule. If you need to undo the rule so that the software is not recognized by Application Control (in other words, delete the rule, not only change its action), see ["Delete an individual Application Control rule" on the next page](#) instead.

1. Go to **Policies > Common Objects > Rules > Application Control Rulesets**.
2. Double-click to select the ruleset that contains the rule that you want to change.

3. On the pop-up window that appears, go to the **Rules** tab.
4. If you want to focus on software that was blocked (or allowed), then in the menu next to **Application Control Rules**, select **By Action** to group similar rules. Alternatively, you can use the search to filter the list.

ACTION	HASH	FILE SIZE (B...)	LAST CHANGE BY	LAST CHANGED
Allow (3)				
Allow	CDEFF41012D3C71FD3DD903B6D4BA0FFA24649115A2EB06E3FC9DDB83EFF7C88	93,258	MasterAdmin	February 1, 2019 07:40
Allow	49381F8DE40E2D2287807FB38D612CCF44D8215BBE9A99C39660D3E5C17A4DAB	92,971	MasterAdmin	February 1, 2019 07:40
Allow	620C6B9FC167162057F7C208D88BFD2F4D9B0ACE9FE926F29BFD3281A761B3311	344,742,846	MasterAdmin	February 7, 2019 05:43

If you want to change the action for a software file, but it has multiple different file names , select **By File Name** to group related rules.

5. Find the row for the specific software that you want to allow or block.
6. In the **Action** column, change the setting to allow or block, then click **OK**.

The next time that the agent connects with Deep Security Manager, the rule will be updated, and the version number will increase.

Delete an individual Application Control rule

If you want to undo a rule that you created, go to **Policies > Common Objects > Rules > Application Control Rulesets**, double-click the ruleset that contains the rule, go to the **Rules** tab, select the rule and then click **Delete**.

Some things to keep in mind:

- When the rules are not needed anymore, you can delete them to reduce the size of the ruleset. This improves performance by reducing RAM and CPU usage.
- If you delete a rule, Application Control will not recognize the software anymore. If the software is installed again, it will appear again on the **Actions** tab.
- If a software update is unstable and you might need to downgrade, keep rules that allow rollback to the previous software version until you have completed testing.

- To find the oldest rules, go to **Policies > Rules > Application Control Rulesets**, then click **Columns**. Select **Date/Time (Last Change)**, click **OK**, and then click that column's header to sort by date.

Delete an Application Control ruleset

If an Application Control ruleset is not being used anymore (for example, if the computer associated with the ruleset no longer exists), you can delete it.

To delete a ruleset, go to **Policies > Rules > Application Control Rulesets**, click a ruleset to select it, and click **Delete**.

Application Control Trust Entities

Trust Entities auto-authorizes software changes that match the properties of "[Trust rules](#)" on [page 1096](#) assigned to "[Trust rulesets](#)" on the next page. Each trust rule contains one or more "[Types of trust rule properties](#)" on [page 1101](#) that define the parameters for auto-authorizing software changes.

By using the Trust Entities feature, you can proactively auto-authorize software changes on Deep Security Agent thus reducing the number of software change events sent to Deep Security Manager. For example, any agent undergoing regular OS updates creates several new software changes each time a patch is applied. By configuring appropriate trust rules and applying them to those agents, you can auto-authorize the software changes on the agent, and avoid having to manually manage them from the Deep Security Manager **Actions** tab or as Application Control security events.

To auto-authorize software changes using Trust Entities, you need to configure "[Trust rules](#)" on [page 1096](#), assign them to "[Trust rulesets](#)" on the next page, and "[Assign or unassign a trust ruleset](#)" on [page 1093](#) to policies or computers.

For information on how to allow or block software changes that are not being auto-authorized with the Trust Entities feature, see "[View and change Application Control rulesets](#)" on [page 1086](#).

In this document, *source* refers to the process that creates a software change, whereas *target* is used when referring to the software change itself.

Tip: API documentation is available for [trust rulesets](#).

Currently, some trust rule properties only apply to agents on supported Windows platforms and are not yet available on Linux. For details, see ["Trust rule property limitations for Linux" on page 1117](#).

Trust rulesets

A trust ruleset consists of one or more user-configured ["Trust rules" on page 1096](#). If you ["Assign or unassign a trust ruleset" on page 1093](#) to a policy or computer in Deep Security Manager, the rules contained in that ruleset are applied to the related workloads and will auto-authorize any software changes that meet its rule property requirements.

Create a trust ruleset

To create a new trust ruleset, do one of the following:

- From the Deep Security Manager **Policies** tab:
 - Go to **Common Objects > Rules > Application Control Rules > Trust Entities**.
 - In the Trust Rulesets section, select **New**.
 - In the New Ruleset window, provide a name and (optionally) a description for the new ruleset.
 - Select one or more of the trust rules in the list to assign them to your trust ruleset.

New Ruleset

Name

Description

ASSIGNED	NAME ▼	DESCRIPTION	CREATED	LAS...	TYPE
▼ Allow from source (2)					
<input type="checkbox"/>	EXAMPLE - Allow from Source - Google Chrome Updater o...	This is an example rule. ...	Novemb...	Nov...	Allow from source
<input checked="" type="checkbox"/>	EXAMPLE - Allow from Source - IBM WebSphere on Linux	This is an example rule. ...	Novemb...	Nov...	Allow from source
▼ Allow by target (2)					
<input checked="" type="checkbox"/>	EXAMPLE - Allow Target - Microsoft .NET product updates	This is an example rule. ...	Novemb...		Allow by target
<input checked="" type="checkbox"/>	EXAMPLE - Allow Target - Trend Micro product updates on ...	This is an example rule. ...	Novemb...		Allow by target
▼ Ignore from source (2)					
<input type="checkbox"/>	EXAMPLE - Ignore from Source - Deep Security Agent upda...	This is an example rule. ...	Novemb...		Ignore from source
<input type="checkbox"/>	EXAMPLE - Ignore from Source - Secure Shell Daemon (ssh...	This is an example rule. ...	Novemb...		Ignore from source

The trust ruleset is created, containing any rules you assigned.

1. From the Deep Security Manager **Computers** or **Policies** tab:
Double-click a computer or policy (or right-click and select **Details**).
2. Go to **Application Control** and make sure the Configuration is set to On or Inherited (On).
3. In the **Trust Ruleset** dropdown list, select **New**.

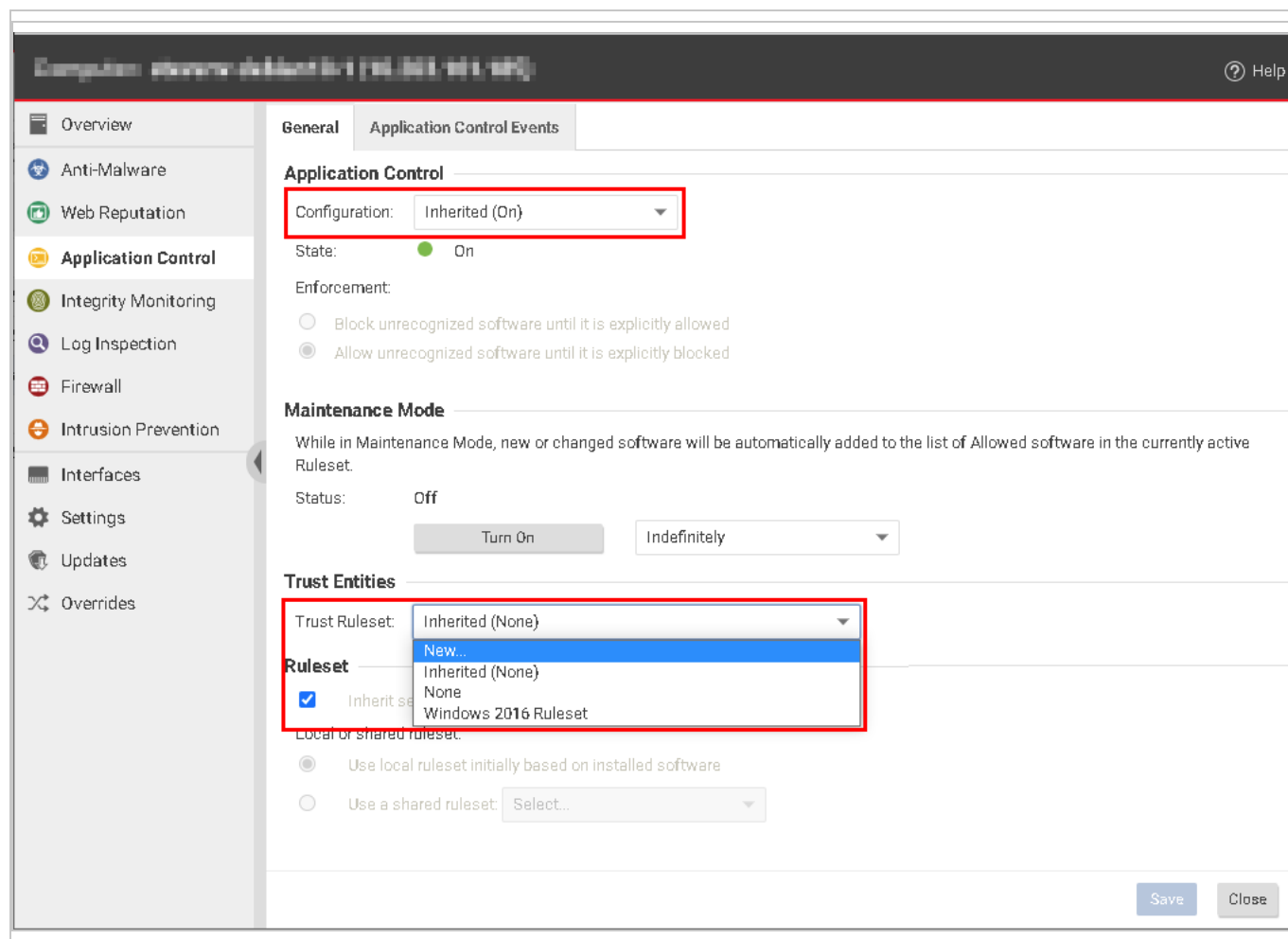

4. In the New Ruleset window, provide a name and (optionally) a description for the new ruleset.

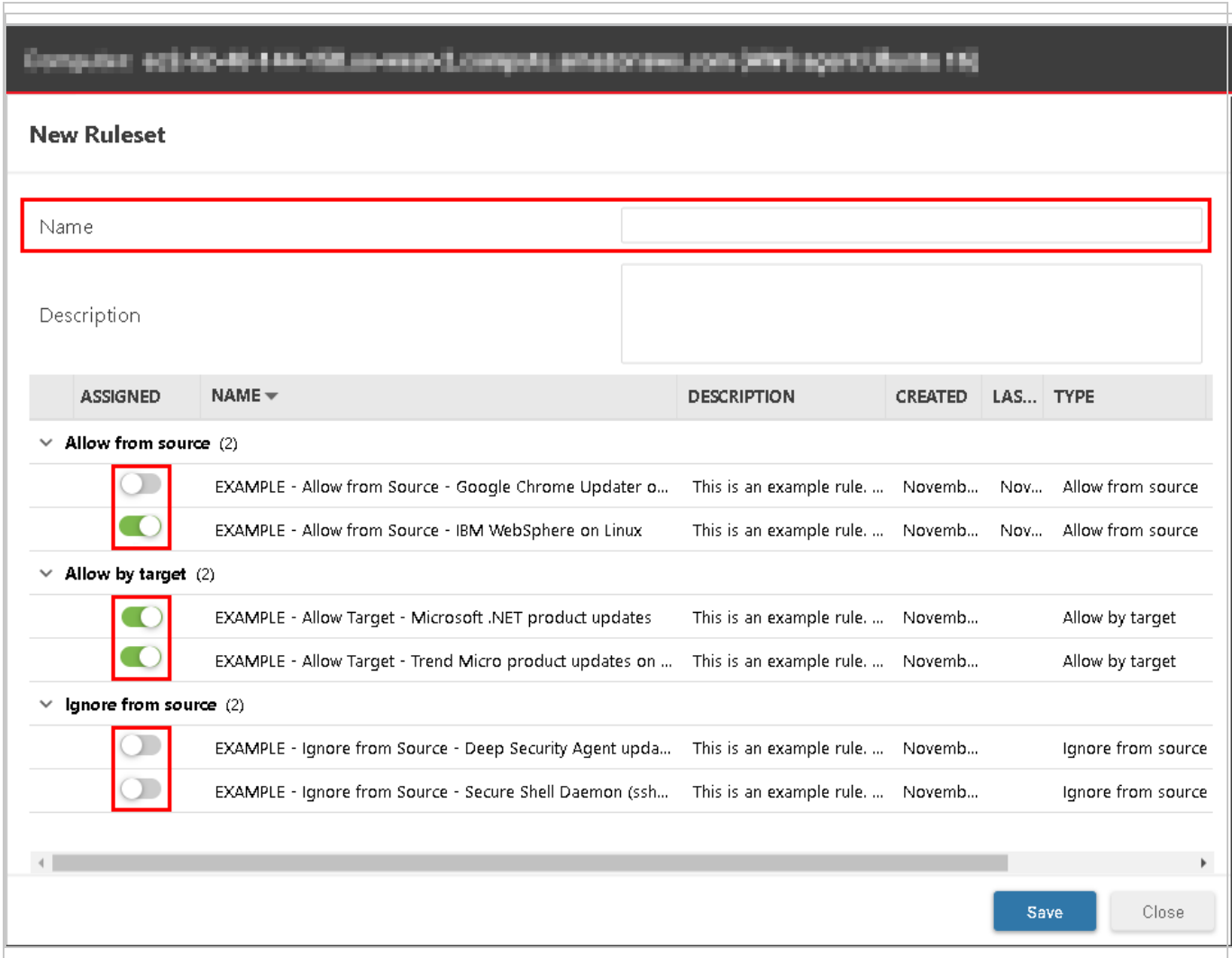

5. Select one or more of the trust rules in the list to assign them to your trust ruleset and select **Save** to create the trust ruleset, containing any rules you assigned.

6. (Optional) To assign the new trust ruleset to the computer or policy, select **Save**.

Tip: Instead of creating a trust ruleset from scratch, you can use the **Duplicate** button from the Trust Entity Management window (**Policies > Common Objects > Rules > Application Control Rules > Trust Entities**) to create a copy of an existing ruleset and then configure it to meet your needs.

Assign or unassign a trust ruleset

To assign a trust ruleset:

1. From the Deep Security Manager **Computers** or **Policies** tab, double-click a computer or policy (or right-click and select **Details**).
2. Go to **Application Control** and make sure **Configuration** is set to On or Inherited (On).
3. Select a **Trust Ruleset** from the dropdown list.



The trust ruleset you selected is now assigned to the computer or policy.

- To unassign a trust ruleset:
1. Go to **Common Objects > Rules > Application Control Rules > Trust Entities** and select the trust ruleset.
 2. In the Trust Ruleset Properties window displayed on the right, select the number next to Assignments.

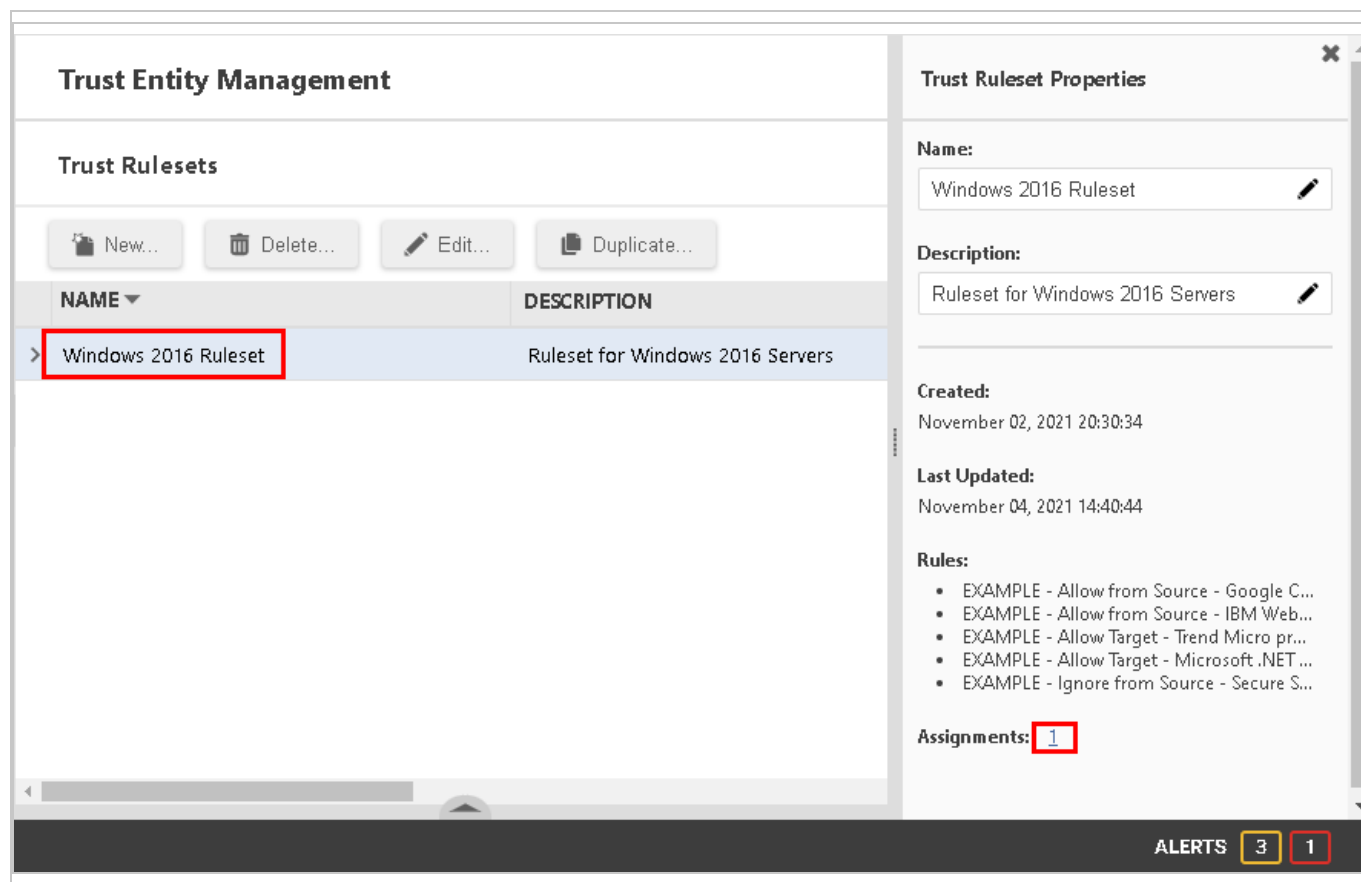

3. In the Assigned To window, select a computer or policy.



4. From the **Application Control** tab of the computer or policy window, unassign the ruleset by

selecting None from the Trust Ruleset dropdown list.

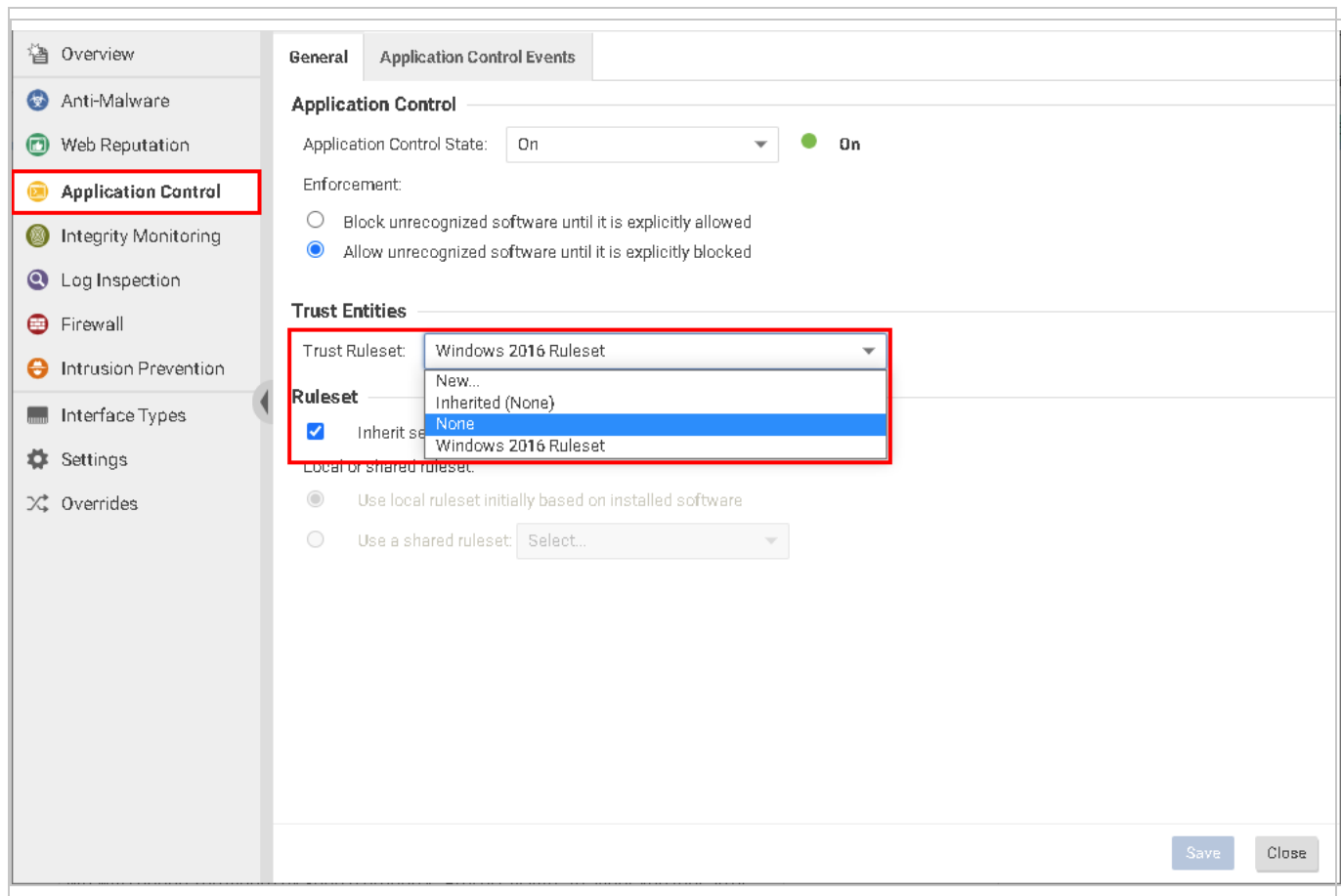

5. Select **Save**.

The trust ruleset is no longer assigned to the computer or policy.

Delete a trust ruleset

1. Go to **Common Objects > Rules > Application Control Rules > Trust Entities**.
2. In the Trust Rulesets section, select the ruleset you want to delete and select **Delete**.

3. From the Delete Ruleset confirmation window, select **OK**.

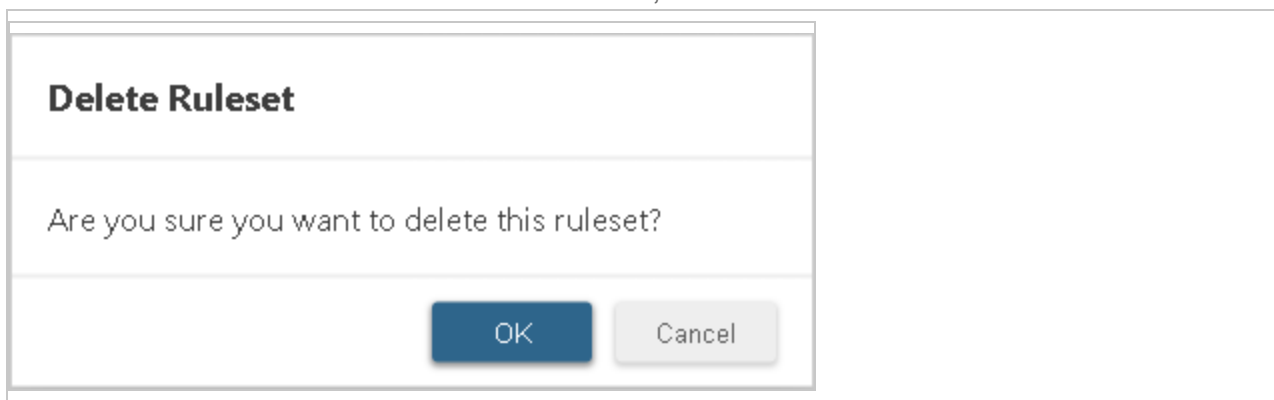

The trust ruleset is deleted.

Note that you cannot delete a trust ruleset if it is currently inherited by or assigned to a computer or policy. You must "[Assign or unassign a trust ruleset](#)" on page 1093 before it can be deleted.

Trust rules

A trust rule contains one or more properties that determine which software changes are auto-authorized by Application Control. Software changes that match the properties of a trust rule are auto-authorized and will not create events in Deep Security Manager.

Warning: Any empty trust rule properties are treated as wildcards. While this gives you freedom in how you customize trust rules, it could also impact the security of your system. To maximize system security and prevent any unwanted software changes from being authorized, try to fill in as many properties as possible when creating trust rules. If you are unsure of the security impact a trust rule might have, check with someone who has a good knowledge of system security or contact Trend Micro before adding it to a trust ruleset.

Types of trust rules

- **Allow from source** rule permits a trusted updater or installer process to install new software on the system. Authorized executable files created by the trusted updater are automatically approved. To use this rule, you need to specify the properties of the source, such as a process or installer, in the rule. In addition, you need to restrict the process to only creating authorized software in specified directories using the "[Paths](#)" on page 1102 attribute. Applying this rule minimizes software change events on the **Actions** page. The Allow from source rule is evaluated during software creation and must be in place prior to running the

installer.

- **Allow by target** rule permits an executable file to run if it matches the specified properties. The properties you specify in the rule must match the properties of the target, such as an executable file. This rule is evaluated at the time of execution, therefore it can be applied after a security event is detected for the file on the **Alerts** page.
- **Block by target** rule prevents an executable file from running if it matches the specified properties. The properties you specify in the rule must match the properties of the target, such as an executable file. This rule is evaluated at the time of execution, therefore it can be applied after a security event is detected for the file on the **Alerts** page.

Note: Block by target rules are supported for Deep Security Agent 20.0.0-3288 or later.

- **Ignore from source** rule sets up a process exclusion, enabling the specified process to execute or create software in designated directories without being monitored by Application Control. When the exclusion rule is removed, the exclusion is immediately lifted. If you only specify the paths with Ignore by source rules, any process can execute or create software in those directories without being monitored by Application Control. This option should only be used if Application Control scanning is causing compatibility problems (for example, performance issues or sharing violations) with some of the processes or paths. The Ignore from source rule overrides any global rules created using the Workload Security API. For more information on global rules, see "[Use the API to create shared and global rulesets](#)" on page 1119.

Every time an Allow from source rule auto-authorizes a software change, an entry is added to the local inventory of the agent where the change occurred. This does not occur for Ignore from source rules.

Warning: When used in an Ignore by source rule, the "[Process Name](#)" on page 1102 property is only supported for for Deep Security Agent 20.0.0-3165 or later.

Create a trust rule

1. Go to **Common Objects > Rules > Application Control Rules > Trust Entities**.
2. In the Trust Rules section, select **New** and select one of the "[Types of trust rules](#)" on the [previous page](#) from the dropdown list.
3. In the New Rule window, provide a name and (optionally) a description for the new rule.

4. Select a property from the Add Property dropdown list to add it to the new rule.

New Rule: Allow from source
Automatically authorize a process with specific properties to create software changes.

Name

Description

Properties

- Add Property...
- Process Name
- SHA-256
- Vendor*
- Product Name*
- Paths

OK Cancel

5. Type the value for the property in the box provided.

Properties

Add Property...

(*) Indicates Windows only property

Product Name* Microsoft® Windows® Operating System Remove

OK Cancel

6. (Optional) To add more properties to this trust rule, repeat steps 4 and 5.
7. Click **OK**.

The new trust rule is created and ready to assign to a trust ruleset.

Tip: For help configuring trust rule property values, see ["Types of trust rule properties" on page 1101](#).

Tip: Select a trust rule (from **Policies > Common Objects > Rules > Application Control Rules > Trust Entities**) and use **Assign/Unassign** to choose which trust rulesets to include it in. This can be especially useful if you want to quickly assign or unassign a new rule across many rulesets.

Change trust rule properties

1. From the Deep Security Manager **Trust Entities** tab (**Policies > Common Objects > Rules > Application Control Rules > Trust Entities**), select a rule and select **Edit** (or double-click a rule).

Edit Rule: Allow by target

Automatically authorize software changes with specific properties.

Name: EXAMPLE - Allow Target - Trend Micro product updates on...

Description: This is an example rule. Allow software changes related to Trend Micro products when signed by a Trend Micro certificate.

Properties

Add Property... (*) Indicates Windows only property

Vendor*	Trend Micro Inc.	Remove
Paths	C:\Program Files\Trend Micro;C:\Program...	Remove
Signer Name*	Trend Micro	Remove
Issuer Common Name (CN)*	Sectigo RSA Code Signing CA	Remove
Issuer Organization (O)*	Sectigo Limited	Remove
Issuer Locality (L)*	Salford	Remove
Issuer State/Province (S)*	Greater Manchester	Remove
Issuer Country (C)*	GB	Remove

OK Cancel

2. In the Edit Rule window, do one of the following:

- To add a new property, select one from the **Add Property** dropdown list and fill in its value.
- To edit an existing property, change the value in its text field.
- To remove an existing property, select **Remove**.

3. Click **OK**.

Delete a trust rule

1. From the Deep Security Manager **Trust Entities** tab (**Policies > Common Objects > Rules > Application Control Rules > Trust Entities**), select a rule and select **Delete**.
2. Click **OK** to confirm the deletion.

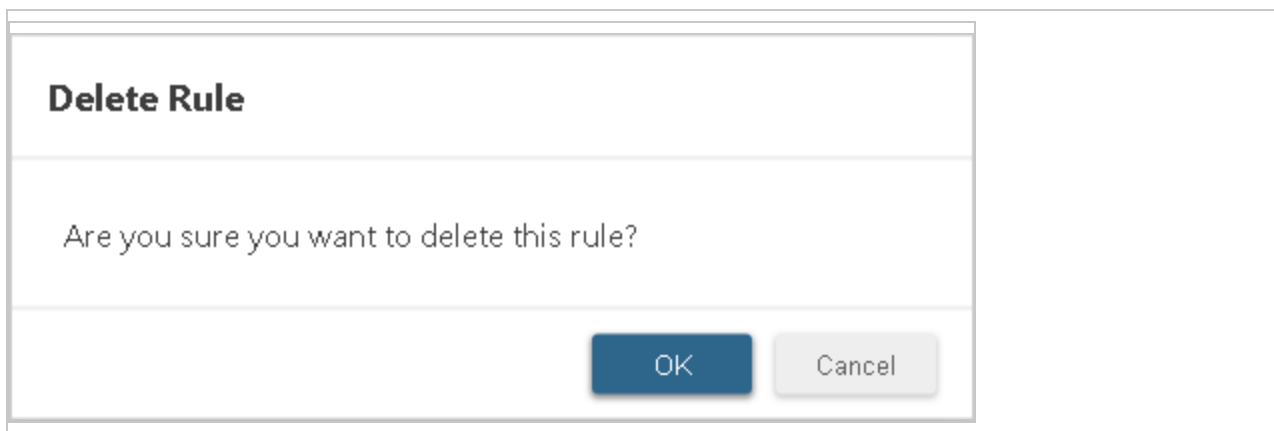

Note: If you delete a trust rule that is currently assigned to any trust rulesets, it will automatically be unassigned from them following a warning prompt

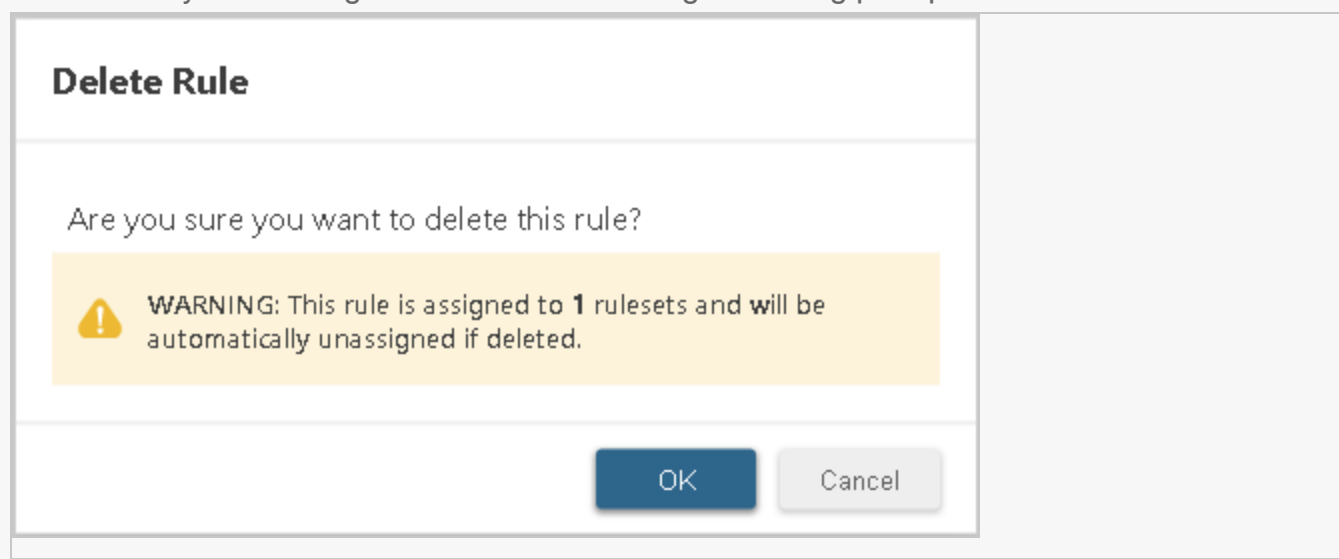

Types of trust rule properties

The properties and values included in a trust rule define which software changes are auto-authorized by that rule. The following sections detail the trust rule property types you can use to configure trust rules, including steps to help you find the information required to configure the property values.

Process Name

Warning: When used in an ["Types of trust rules" on page 1096](#) rule, the process name property is only supported for Deep Security Agent 20.0.0-3165 or later.

This property specifies the name of the process creating software changes. The process name must use the absolute path of the process, including its file name.

To find a process name of a software change:

1. Go to Deep Security Manager's **Actions** tab.
2. Find and select the software change.

The process displays on the right under Changed By Process along with other details.

Deep Security Agent uses wildcards for process names. When a process name includes the full path to the process:

- the globstar `**` in a path matches any number of additional characters within the process name;
- the globstar `**` matches any number of additional characters within the process name;
- a single asterisk or star `*` matches any number of additional characters with the current directory only;
- a `?` matches a single character.

The `*` character stops its search at directory path delimiters (`/` and `\`). The `?` character does not match match directory path delimiters. Drive letters are treated like any other characters in the target path and hold no special significance for matching.

Paths

This property specifies the target paths applied to a trust rule. Application Control automatically authorizes software changes if they occur within a path entered for this property, including all subdirectories and file names. You can set multiple paths separated by a semicolon. For example, `C:\Windows\;C:\Program Files\`.

When entering values for paths, consider how the last slash (`\` or `/`) in a path affects which directories are included:

- A path ending with a slash matches all subdirectories under that full path. For example, `C:\Windows\System\` would match any subdirectories in the `System` directory.
- A value specified after the last slash is treated as a regular expression wild card and

matches the specific directory, as well as any other directories that start with the same value. For example, `C:\Windows\System` would include all directories and subdirectories that match "`C:\Windows\System*`" including `C:\Windows\System\`, `C:\Windows\System32\`, `C:\Windows\SystemApps\`, and so on.

Deep Security Agent version 20.0.0-5137 and later supports globstar (`**`) wildcard. Using globstar `**` in a path matches any number of additional characters within the current directory and its subdirectories, a single asterisk (`*`) matches any number of additional characters within the current directory only, and a question mark (`?`) matches a single additional character. Drive letters or drive delimiters (`/` or `\`) are treated like any other characters in the target path and hold no special significance for matching, except for `*` which stops at forward slash (`/`) or back slash (`\`) characters.

SHA-256

When used in an Allow from source rule, this specifies the checksum (SHA-256) of the source process creating a software change. When used in an Allow by target rule, it is the checksum (SHA-256) of the software change itself.

To find the SHA256, do one of the following:

From Windows PowerShell (for source or target):

Follow instructions in the [Windows PowerShell command Get-FileHash](#).

From Deep Security Manager (for target only):

From Deep Security Manager's **Actions** tab, find and select the software change.

The SHA256 will be displayed on the right along under SHA256 along with other details.

Vendor

This property, which is currently supported only on Windows, specifies the software vendor.

To find the vendor, do one of the following:

From File Explorer:

1. From the directory containing the process or file, right-click on one of the properties displayed at the top of File Explorer (Name, Date modified, etc.) and select **More**.
2. Select **Company** and click **OK**.

The vendor will be displayed in the File Explorer window.

From Deep Security Manager:

From Deep Security Manager's **Actions** tab, find and select the software change.

The vendor will be displayed on the right under Vendor along with other details.

Product Name

This property, which is currently supported only on Windows, specifies the software product name.

To find the product name, do one of the following:

From file properties:

1. From the directory containing the file, right-click the process or file and select **Properties**.
2. From the **Details** tab, look at the value for Product Name.

From File Explorer:

1. From the directory containing the file, right-click on one of the properties displayed at the top of File Explorer (Name, Date modified, etc) and click **More**.
2. Select **Product name** and click **OK**.

The product name will be displayed in the **Product name** column.

From Deep Security Manager:

From Deep Security Manager's **Actions** tab, find and select the software change.

The product name will be displayed on the right under Product Name along with other details.

Signer Name

When used in an Allow from source rule, this specifies the signer name of the source process creating a software change. When used in an Allow by target rule, it is the signer name in the certificate that signed the target file.

This property, which is currently supported on Windows only, specifies the name of the company that signed the software certificate.

To find the certificate signer name:

1. Right-click the process or file and select **Properties**.
2. On the **Digital Signatures** tab, find the name of the signer in **Signature list**.

The signer name is displayed under **Signer Name**

To eliminate the maximum amount of software change events or security events, use the signer name rule property to match all events from a specific signer.

Issuer Common Name

This property, which is currently supported only on Windows, specifies the issuer common name (CN) of the signing software certificate.

To find the issuer common name:

1. Right-click the process or file and click **Properties**.
2. From the **Digital Signatures** tab, select the first certificate you see on the **Signature** list.
3. Select the certificate and click **Details**.
4. Select **View Certificate**.
5. Go to the **Details** tab and select **Issuer**.

If included in the certificate, the issuer CN is displayed under Issuer.

Issuer Organizational Unit

This property, which is currently supported only on Windows, specifies the issuer organizational unit (OU) of the software certificate.

To find the issuer organizational unit:

1. Right-click the process or file and select **Properties**.
2. From the **Digital Signatures** tab, select the first certificate you see on the signature list.
3. Select the certificate and click **Details**.
4. Click **View Certificate**.
5. Go to the **Details** tab and select **Issuer**.

If included in the certificate, the issuer OU is displayed.

Issuer Organization

This property, which is currently supported only on Windows, specifies the issuer organization (O) of the software certificate.

To find the issuer organization:

1. Right-click the process or file and click **Properties**.
2. From the **Digital Signatures** tab, select the first certificate you see on the signature list.
3. Select the certificate and click **Details**.
4. Click **View Certificate**.
5. Go to the **Details** tab and select **Issuer**.

If included in the certificate, the issuer O is displayed.

Issuer Locality

This property, which is currently supported only on Windows, specifies the issuer locality (L) of the software certificate.

To find the issuer locality:

1. Right-click the process or file and click **Properties**.
2. From the **Digital Signatures** tab, select the first certificate you see on the signature list.
3. Select the certificate and click **Details**.
4. Click **View Certificate**.
5. Go to the **Details** tab and select **Issuer**.

If included in the certificate, the issuer L is displayed.

Issuer State or Province

This property, which is currently supported only on Windows, specifies the issuer state or province (S) of the software certificate.

To find the issuer state or province:

1. Right-click the process or file and click **Properties**.
2. From the **Digital Signatures** tab, select the first certificate you see on the signature list.
3. Select the certificate and click **Details**.
4. Click **View Certificate**.
5. Go to the **Details** tab and select **Issuer**.

If included in the certificate, the issuer S is displayed.

Issuer Country

This property, which is currently supported only on Windows, specifies the issuer country (C) of the software certificate.

To find the issuer country:

1. Right-click the process or file and click **Properties**.
2. From the **Digital Signatures** tab, select the first certificate you see on the signature list.
3. Select the certificate and click **Details**.
4. Click **View Certificate**.
5. Go to the **Details** tab and select **Issuer**.

If included in the certificate, the issuer C is displayed.

Application Control event aggregation and analysis

Dynamic software updates on a server can cause thousands of drift events (**Action** page) and security events (**Application Control Events** page). This presents a challenge in the use of Application Control, as it is difficult to know what to approve after the fact. To mitigate the situation while using Deep Security Agent 20.0.0.5761 or later, you can create trust rules that allow you to only see atypical drift and security events. This also allows you to put your server in lockdown to prevent any unauthorized software from being executed.

Drift events are aggregated based on the process name and target path. Security events are aggregated based on the SHA256 hash and target path. For example, if the same process creates 10,000 drift items at the same path, the drift would be aggregated to a single trust rule with the `processName` and `paths` attributes.

When diagnostics are requested for the agent, the aggregated drift events and security events are stored in a trust rule format in a JSON file and included in the diagnostics. The JSON file can then be used by the **Trust Rule** editor to add the trust rules for the server.

Drift events

A drift event in the JSON format has the following attributes:

```
{"time":1615999592250,"eventType":"ApplicationControl","uid":1063
```

```
, "gid":1064, "operationType":"create", "user":"ribapp", "group":"rib
app",

"md5":"57579EF7681147B84774F69F44783A67", "sha256":"90B0418DCB3B29
440EE6F69FEE05BD54265CEE3BCFABDA8ED355E257FECC2939",

"processName":"/opt/IBM/WebSphere/AppServer/java/jre/bin/java", "t
ype":4, "rdev":0, "lastModificationTime":1615999090000, "mode":33188
, "size":3984617,

"sha1":"B226BDB9DB39AD38C4BEB6FE4F1C1C7151207848", "nlink":1, "proc
User":"ribapp", "isAuthorized":1, "pid":10223, "fileExtension":"ja
r",

"operationDate":1615999591534, "procUid":1063, "procGroup":"ribapp"
, "path":"/opt/IBM/WebSphere/AppServer/profiles/devmiesAppSrv/inst
alledApps/devdmrhx01-
cell02/IESHSRIDEVM.ear/", "fileName":"DC.jar", "recordTime":1615999
592215, "fileSystemType":"ext4", "procGid":1063, "dev":64775, "source
":4, "ino":3801778}
```

- `processName` is the name of the process that created or updated the target file. In the preceding example, it is set to `/opt/IBM/WebSphere/AppServer/java/jre/bin/java`.
- `path` is the location in which the process updated or created the executable file. In the preceding example, it is set to `/opt/IBM/WebSphere/AppServer/profiles/devmiesAppSrv/installedApps/devdmrhx01-cell02/IESHSRIDEVM.ear/`.

Trust rules for drift events

You can create a trust rule to auto-authorize the drift for an event. A trusted updater can be defined via setting `trustType` to 1 for this rule, and you are trusting the process to create software in any path listed in `paths`:

```
"trustrules": [{
```

```

    "trustType": "1",

    "processName": "/opt/IBM/WebSphere/AppServer/java/jre/bin/java",

    "paths": "/opt/IBM/WebSphere/AppServer/profiles/devmiesAppSrv/installedApps/devdmrhx01-cell102/IESHSRIDEVM.ear/"
  }, ]

```

Processing drift events to create trust rules can be a many-to-one operation. For example, if the process named `/opt/IBM/WebSphere/AppServer/java/jre/bin/java` creates thousands of JAR files in path

`/opt/IBM/WebSphere/AppServer/profiles/devmiesAppSrv/installedApps/devdmrhx01-cell102/IESHSRIDEVM.ear/`, the preceding trust rule will eliminate drift for all of these JAR files, which makes trust rules efficient at aggregating the drift.

A trust rule consists of an array of rules, with one unique process per rule. Each trust rule can have multiple paths defined in its `paths` attribute. For example, if a process named `process1` has created drift at three distinct locations `path1`, `path2`, `path3`, one trust rule can capture all drift created by `process1` at all of these locations:

```

"trustrules": [{
  "trustType": "1",
  "processName": "process1",
  "paths": "path1;path2;path3"
}, ]

```

There is an additional attribute called `hitcount` whose purpose is a process hit count. You can use this attribute to determine how many times a specific trust rule has been hit.

There is also an extension hit count: extensions are tracked by incrementing each time the process updates a file with a particular extension:

```

"trustrules": [{
  "trustType": "1",
  "processName": "process1",
  "paths": "path1;path2;path3",

```

```
        "hitcount":12342,  
        ".jar":1234,  
        ".py":323,  
        ".":456  
    }, ]
```

The preceding example shows a process that has updated JAR files 1234 times, pi files 323 times, and files with no extensions 456 times.

Security events

A security event in the JSON format has the following attributes:

```
"  
{time":1492100772165,"eventType":"ApplicationControl","sha1":"066  
A02D230F3B16439396B049DC  
  
912DB376B96CE","fileName":"svchost.exe","operationType":"detectOn  
ly","blockReason":2,"size":31  
  
1544,"sha256":"62EFB22F6853D73374761A0B8ED2CE40BF09AA401EC7D4AAAA  
0CE4D5C3380EEA","type":1,  
  
"path":"C:\\Windows\\System32\\","pid":1832,"operationDate":  
  
1492100772149,"processName":"\\device\\harddiskvolume2\\windows\\  
system32\\cmd.exe","md5":  
    "5F7B8544F7A20800069107FC93384F0E"},  
  
{"time":1492100772165,"eventType":"ApplicationControl","blockReas  
on":2,"sha256":"62EFB22F6  
  
853D73374761A0B8ED2CE40BF09AA401EC7D4AAAA0CE4D5C3380EEA","size":3  
11544,"processName":"\\de
```

```

vice\\harddiskvolume2\\windows\\system32\\cmd.exe", "sha1": "066A02
D230F3B16439396B049DC912D

B376B96CE", "operationType": "detectOnly", "pid": 1832, "md5": "5F7B854
4F7A20800069107FC93384F0E

", "path": "C:\\Program Files\\Trend Micro\\Deep Security
Agent\\", "operationDate": 149210077}

```

In the preceding example, `sha256` is set to

`62EFB22F6853D73374761A0B8ED2CE40BF09AA401EC7D4AAAA0CE4D5C3380EEA` and `path` is set to `C:\\Windows\\System32\\`.

Trust rules for security events

You can create a trust rule to auto-authorize the drift for a security event. A trusted target can be defined via setting `trustType` to 2 for this rule, based on SHA256 hash, in any path listed in `paths`:

```

"trustrules": [{
    "trustType": "2",

    "sha256": "62EFB22F6853D73374761A0B8ED2CE40BF09AA401EC7D4AAAA0CE4D
5C3380EEA",
    "paths": "C:\\Windows\\System32\\"
}, ]

```

Processing security events to create trust rules is a complex operation. A trust rule consists of an array of rules, with one unique SHA256 per rule. Each trust rule can have multiple paths defined in its `paths` attribute. For example, if a file is executed with a `sha256` content hash `AAAAAAAAABBBBBBBBCCCCCCCCDDDDDDDDDD` from distinct locations `path1`, `path2`, `path3`, one trust rule can represent this as follows:

```

"trustrules": [{
    "trustType": "2",

```

```

    "sha256": "AAAAAAAABBBBBBBBCCCCCCCCDDDDDDDDDD",
    "paths": "path1;path2;path3"
  }, ]

```

There is an additional attribute called `hitcount` whose purpose is a SHA256 hit count. You can use this attribute to determine how many times a specific trust rule has been hit.

There is also a file name hit count: files with different names can have the same SHA256 content hash. You can use this attribute to count the number of times a file with a specific name has been used to execute the same SHA256. In the following example, SHA256

`AAAAAAAABBBBBBBBCCCCCCCCDDDDDDDDDEEEEEEEEE` has been executed 12342 times, `filename1` has been used 2342 times, and `filename2` has been used 10000 times. Both `filename1` and `filename2` have the same content hash.

Since processes with different names can execute the same target with the same SHA256 content hash, you can also count the number of times that the process name was used to execute the same SHA256. In the following example, SHA256

`AAAAAAAABBBBBBBBCCCCCCCCDDDDDDDDDEEEEEEEEE` has been executed 12342 times, `filename1` has been used 2342 times, and `filename2` has been used 10000 times. Both `filename1` and `filename2` have the same content hash. Process name `/opt/process1` was used to execute the target 12000 times and `/opt/process2` was used to execute the target 342 times.

```

"trustrules": [{
  "trustType": "2",
  "sha256": "AAAAAAAABBBBBBBBCCCCCCCCDDDDDDDDDEEEEEEEEE",

  "paths": "path1;path2;path3",
  "hitcount": 12342,
  "filename1": 2342,
  "filename2": 10000
  "/opt/process1": 12000,
  "/opt/process2": 342
}, ]

```

Note that a process is represented with a full path, while the file name is included in a relative path to one of the paths.

Event analysis output

The Application Control event analysis output is directed to a file called `ac_event_analysis.txt`. This file has a trust rule format with additional hit count attributes and extension hit count attributes:

```
trustrules": [{
  "trustType": "1",
  "processName": "process1",
  "paths": "path11;path12;path13",
  "hitcount": 12342,
  ".jar": 12342
}
{
  "trustType": "1",
  "processName": "process2",
  "paths": "path21;path22;path23",
  "hitcount": 23232,
  ".py": 23232
}
{
  "trustType": "1",
  "processName": "process3",
  "paths": "path31;path32;path33",
  "hitcount": 34332,
  ".exe": 34322
}
{
  "trustType": "1",
  "processName": "process4",
  "paths": "path41;path42;path43",
  "hitcount": 12312,
  ".": 12312
}, ]
```

The file locations are as follows:

- On Windows: `C:\ProgramData\Trend Micro\Deep Security Agent\diag\ac_event_analysis.txt`.
- On Linux: `/var/opt/ds_agent/diag/ac_event_analysis.txt`.
- In the diagnostics: `agent/ac/ac_event_analysis.txt`.

The analysis is loaded from this file on restart so that the state is maintained after an agent restart. The analysis is cleared when Application Control is enabled after having been disabled. To view the `ac_event_analysis.txt` file, either use [JQ](#) or an [online JSON formatter](#).

Debug trust rules

You can debug trust rules as follows:

1. Apply new trust rules to Deep Security Manager.
2. Stop Deep Security Agent.
3. Delete the `ac_event_analysis.txt` file.
4. Start Deep Security Agent.
5. Wait a few minutes to see if the `ac_event_analysis.txt` file reappears:
 - If the file no longer appears, then the trust rules are working and suppressing the event generation.
 - If the file still appears, inspect the `ac_event_analysis.txt` file for the new event information and add new trust rules accordingly. Trust type 1 rules are Allow by source rules for auto-approving drift events, whereas trust type 2 rules are Allow by target rules to allow execution of the target file.
6. To configure new trust rules, repeat the procedure starting from step 1.

To see how often the trust rules are being hit, execute `sendCommand` on the agent, as follows:

- Linux: `/opt/ds_agent/sendCommand --get TrustRules`
- Windows: `\program files\trend micro\deep security agent\sendCommand --get TrustRules`

Consult metrics

The drift analysis and event analysis are added to the Application Control metrics, where top ten processes with the highest hit counts are included in the `drift_analysis` object and the top ten SHA256 with the highest counts are stored in the `event_analysis` object:

```
"AC": {
  "eventReportInQueue": "0",
  "evtPreCreateProcessHandled": "17",
  "acProcessHashCount": "0",
  "acProcessBlockUnrecognized": "0",
  "engFlushDbBufferError": "0",
  "acFileProcessImgPath": "0",
  "evtFilePostClose": "249",
  "acFileErrorHash": "0",
  "acFileAllowImportingRuleset": "0",
  "evtFilePreCreateFromContainer": "0",
  "evtFilePostChmodFromContainer": "0",
  "engStopError": "0",
  "evtFilePreCreateHandled": "0",
  "ctrlInterpreterMatched": "0",
  "engPurgeDb": "0",
  "importCount": "0",
  "inventoryAdsVisited": "0",
  "engGetInventory": "1",
  "acFileAllow": "5",
  "acFileAllowBuilding": "0",
  "engSetConfigError": "0",
  "ctrlMsiInstallationMatched": "0",
  "ctrlDropProcessEvtReportQueueFull": "0",
  "importFail": "0",
  "eventReportDropped": "0",
  "evtFilePostChmod": "3",
  "acFileBlock": "0",
  "acFileDrift": "3",
  "engGetMetricsError": "0",
  "ctrlDropFileEvtReportQueueFull": "0",
  "inventoryFolderVisited": "0",
  "engStartError": "0",
```

```

"evtFileCloudFileIgnore": "0",
"engSetConfig": "1",
"engFlushDbBuffer": "0",
"engPurgeDbError": "0",
"inventoryBytesInventoried": "433695822",
"evtPreCreateProcessWithCmdLine": "0",
"inventoryDriveVisited": "0",
"importSuccess": "0",
"engSetRuleset": "0",
"eventReportSent": "3",
"drift_analysis": [
  {
    "trusttype": "1",
    "processName": "/usr/bin/bash",
    "hitcount": 2,
    "paths": "/im1"
  },
  {
    "trusttype": "1",
    "processName": "/usr/bin/cp",
    "hitcount": 1,
    "paths": "/im1"
  }
],
"event_analysis": [
  {
    "trusttype": "2",
    "sha256": "AAAAAAAAABBBBBBBBCCCCCCCCDDDDDDDDDEEEEEEEEE",
    "hitcount": 2,
    "paths": "/im1"
  },
  {

```

```
        "trusttype": "2",  
  
        "sha256": "EEEEEEEEEDDDDDDDDDCCCCCCCCBBBBBBBBBAAAAAAAA",  
        "hitcount": 1,  
        "paths": "/im1"  
    }  
],
```

View signer information

When trust rules are enabled, both the file signer information and process signer information are included in trust rules for the drift events analysis. For security event analysis, the file signer information is included.

Trust rules are enabled (the file signer information along with the process signer information is visible in the `ac_event_analysis.txt` file) when a trust entity ruleset is applied to the host.

Trust rule property limitations for Linux

Warning: Adding trust rules that are not currently supported on Linux will result in the rules not applying for any software changes.

The following trust rule properties are not currently supported for Linux:

- Signer Name
- Product Name
- Issuer Common Name
- Issuer Organizational Unit
- Issuer Organization
- Issuer Locality
- Issuer State or Province
- Issuer Country
- Vendor

Only the following trust rule properties are currently supported for Linux:

- Process Name
- Paths
- SHA-256

Reset Application Control after too much software change

For an overview of Application Control, see ["About Application Control" on page 1069](#).

Application Control is intended for use on stable servers that are not updated frequently, and not for workstations or servers that undergo a lot of software changes.

Too many changes make large rulesets that consume more RAM, unless you remove old rules. If you don't use maintenance mode during authorized software updates, too many changes can also result in high administrator workload because they must manually create allow rules for each change.

If unrecognized software changes exceed the maximum, Application Control will stop detecting and displaying all of the computer's software changes. This stoppage is designed to prevent out-of-memory and disk space errors that can occur if the ruleset grows too large.

When a stoppage occurs, Deep Security Manager will notify you through an alert ("Unresolved software change limit") and an event log ("Unresolved software change limit reached"). You must resolve the issue to continue detecting software changes.

1. Examine the computer's processes and security events. Verify that the computer has not been compromised. If you are not sure, or do not have enough time, the safest and fastest way is to restore the system from a backup or VM snapshot.

Warning: If you don't remove any unauthorized software (including zero-day malware), Application Control will ignore it when you reset Application Control. It won't appear on the Actions tab anymore and if its process has already executed and it is in RAM, Application Control won't log any events or alerts about it until you reboot the computer.

2. If the computer was running software updates, including auto-updates (for example, browser, Adobe Reader, or yum auto-updates), disable them or schedule them so that they occur only when you have enabled Application Control's maintenance mode (see ["Turn on maintenance mode when making planned changes" on page 1080](#)).

3. Reset Application Control. To do this, disable Application Control in the **Computer editor**¹. Once the agent has acknowledged it and cleared the error status, enable Application Control again. The agent generates a new software inventory list.

Use the API to create shared and global rulesets

For an overview of Application Control, see ["About Application Control" on page 1069](#). For initial configuration instructions, see ["Set up Application Control" on page 1075](#).

Using the Deep Security Manager API on the [Automation Center](#), you can create shared rulesets and global rules. You can use one type of ruleset, or a combination. For more information, see [Create a shared ruleset](#) and [Add global rules](#).

- **Local ruleset:** Rules that are added as part of a computer's software inventory or when in maintenance mode are stored only on the protected computer and are not visible in Deep Security Manager. Allow or block rules that you configure in Deep Security Manager are sent to the agent and stored in both places. Because agents don't transfer their inventory information to the manager, local rulesets offer better performance than shared rulesets.

To determine whether software is new or has changed, Deep Security Agent 10 compares the file with the initially installed software's SHA-256 hash, file size, path, and file name (they have a "file-based" local ruleset). Deep Security Agent 11 and newer compares only the file's SHA-256 hash and file size (they have a "hash-based" local ruleset). Because the rules created by Deep Security 11 (and newer) agents compare only the unique hash and file size, a rule will continue to be applied even if the software file is renamed or moved. As a result, using Deep Security Agent 11 or newer reduces the number of software changes that you need to deal with. Deep Security Agent 10 continues to use a file-based local ruleset until it is upgraded to Deep Security Agent 11.0 or newer. When you upgrade, its local ruleset is converted to use hash-based rules.

Note: If there are multiple file-based rules for the same hash value, they are consolidated into one hash-based rule. If the rules being consolidated conflict with each other (one rule blocks the file and another allows it), the new hash-based rule will be an "allow" rule.

¹To open the Computer editor, go to the Computers page and double-click the computer that you want to edit (or select the computer and click Details).

- **Shared ruleset:** Syncs all of its rule data onto both agents and manager (and also relays, if enabled). This increases network and disk space usage. However, it may be easier if you need to verify the rules from the initial inventory scan or maintenance mode, or if you manage a server farm with many computers that should be identical. For example, if you have a server pool of identical LAMP web servers, or if they are virtual machines (VMs) that are part of an auto-scaling group, shared rulesets can be useful. It can also reduce administrator workload.

Warning: Don't use a shared ruleset if you enabled **Block unrecognized software until it is explicitly allowed**, and if computers are merely similar (but not identical). It will block all software on other computers that isn't in the first computer's ruleset. If those include critical files, it could break the OS. If that happens, you may be required to reinstall, revert to a backup, or use the OS recovery mode.

When you create a new shared ruleset using Deep Security Agent 11.1 or newer, it can only contain hash-based rules (rules that compare only a file's hash and size). If you created a shared ruleset using Deep Security Agent 11.0 or earlier, it contains file-based rules (rules that compare a file's name, path, size, and hash). Older shared rulesets will continue to use file-based rules until all agents using the shared ruleset are upgraded to Deep Security Agent 11.0 or newer. Then the shared ruleset will be converted to use hash-based rules.

Warning: Don't create a new shared ruleset until all agents are upgraded to Deep Security Agent 11.0 or newer. New shared rulesets are hash-based and are not compatible with Deep Security Agent 10.3 or earlier, which supports only file-based rulesets.

Note: If there are multiple file-based rules for the same hash value, they are consolidated into one hash-based rule. If the rules being consolidated conflict with each other (one rule blocks the file and another allows it), the new hash-based rule will be an "allow" rule.

To create shared rules, see [Create a shared ruleset](#) on the Automation Center.

- **Global rules:** Like shared rulesets, global rules are distributed to agents by the manager (and also relays, if enabled). This increases network and disk space usage. However, because they are global, you don't need to spend time selecting them in each policy.

Global rules aren't part of the rulesets you can see in Deep Security Manager. Global rules can only contain block rules, not allow rules.

Global rules require Deep Security Agent 10.2 or newer. The manager will not send the global rules to older agents. Global rules take precedence over all other Application Control rules and are enforced on all computers where Application Control is enabled. The rules in global rules are based on a file's MD5, SH-1 or SHA-256 hash. Because a software file's hash is unique, you can block specific software everywhere – regardless of file path, policy, or computer group, and regardless of whether Application Control has detected the software before.

Note: In a multi-tenant deployment, each tenant has a separate global rules. To block software for all tenants, create the same global rules for each tenant.

To create global rules, see [Add global rules](#) on the Automation Center.

In this article:

- ["Create a shared ruleset" below](#)
- ["Change from shared to computer-specific allow and block rules" on the next page](#)
- ["Deploy Application Control shared rulesets via relays" on page 1123](#)
- ["Considerations when using relays with shared rulesets" on page 1124](#)

Create a shared ruleset

You can use the API to create shared allow or block rules and apply the ruleset to other computers. This can be useful if you have many identical computers (such as a load balanced web server farm). **Shared rulesets should be applied only to computers with the exact same inventory.**

1. Use the API to build a computer's shared allow and block rules. For more information, see [Create a Shared Ruleset](#). If you want to examine the shared ruleset before you deploy it, see ["View and change Application Control rulesets" on page 1086](#).
2. Go to **Computer or Policy editor**¹ > Application Control.
3. In the ruleset section, make sure **Inherit settings** is not selected and then select **Use a shared ruleset**. Indicate which shared rules to use.

¹You can change these settings for a policy or for a specific computer. To change the settings for a policy, go to the Policies page and double-click the policy that you want to edit (or select the policy and click Details). To change the settings for a computer, go to the Computers page and double-click the computer that you want to edit (or select the computer and click Details).

Note: These settings are hidden until you use the API to create at least one shared ruleset. If you haven't created any shared rulesets, or if you keep the default settings, each computer will keep its own allow and block rules locally. Changes to local rules don't affect other computers.

4. Click **Save**.

The next time that the Deep Security Agent on the computer connects with Deep Security Manager, the agent applies those rules.

If you see an error saying that the ruleset upload was not successful, verify that network devices between the agent and the manager or relay allow communications on the heartbeat port or relay [port numbers](#).

Change from shared to computer-specific allow and block rules

If the computer is currently using shared allow or block rules created via the API, you can change it to use local rules. Application control scans the file system for all currently-installed software and creates an initial ruleset for it, similar to when you first enabled Application Control.

Warning: Before you start, verify that only good software is currently installed. Rebuilding the ruleset will allow all currently installed software, even if it is insecure or malware. If you are not sure what is installed, the safest approach is to make a clean install and then enable Application Control.

The steps below configure a computer's agent to use a local ruleset. If you want all computers to use local rules, edit the setting in the **Policies** tab instead.

1. Go to **Computer editor**¹ > **Application Control**.
2. In the ruleset section, deselect **Inherit settings** (if necessary), and then select **Use local ruleset initially based on installed software**.
3. Click **Save**.

To verify the change, the next time the agent and Deep Security Manager connect, look for [event log messages about building the Application Control ruleset](#).

¹To open the Computer editor, go to the Computers page and double-click the computer that you want to edit (or select the computer and click Details).

Deploy Application Control shared rulesets via relays

Each time you create an Application Control ruleset or change it, it must be distributed to all computers that use it. Shared rulesets are bigger than local rulesets. Shared rulesets are also often applied to many servers. If they all downloaded the ruleset directly from the manager at the same time, high load could cause slower performance. Global rulesets have the same considerations.

Using Deep Security Relays can solve this problem. (For information on configuring relays, see ["Deploy additional relays" on page 1415.](#))

Steps vary depending whether or not you have a multi-tenant deployment.

Single tenant deployments

Go to **Administration > System Settings > Advanced** and then select **Serve Application Control rulesets from relays**.

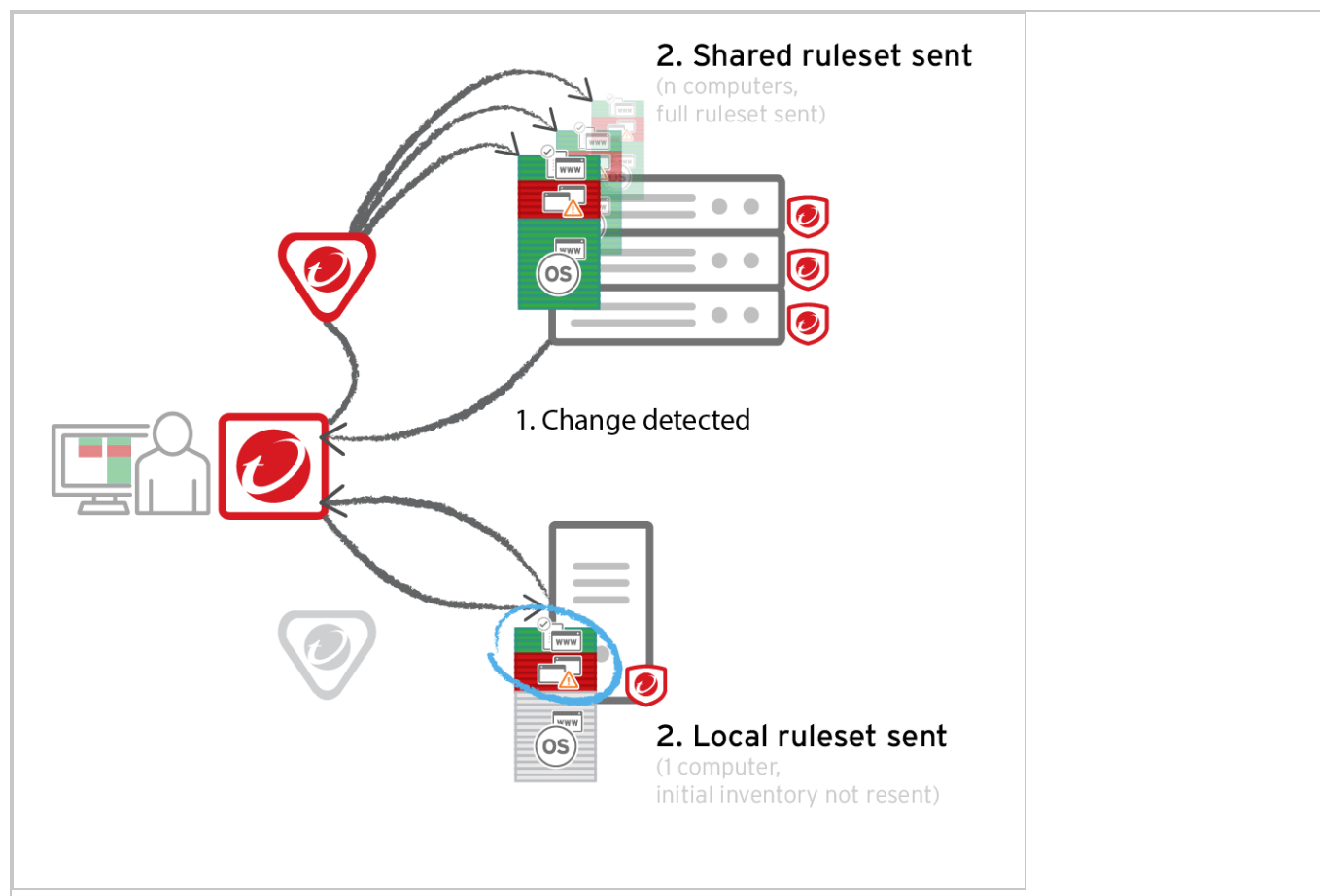

Multi-tenant deployments

The primary tenant (t0) can't access other tenants' (tN) configurations, so t0 relays don't have tN Application Control rulesets. Other tenants (Tn) must create their own [relay group](#), then select **Serve Application Control rulesets from relays**.

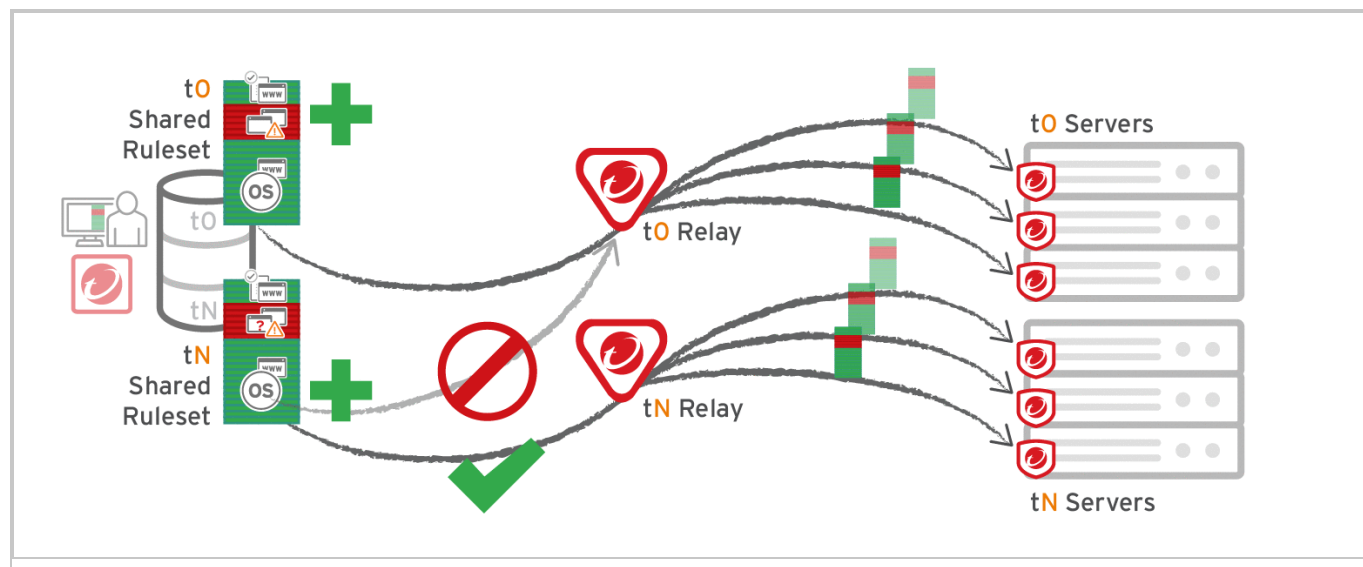

Considerations when using relays with shared rulesets

Before using relays, verify that they are compatible with your deployment. If the agent doesn't have any previously downloaded ruleset currently in effect, and if it **doesn't receive new Application Control rules**, then the computer won't be protected by Application Control. If Application Control ruleset download fails, a ruleset download failure event will be recorded on the manager and on the agent.

- If you are using a proxy to connect agents to a manager, you must use a relay.

Note: In Deep Security Agent 10.0 and earlier, agents didn't have support for connections through a proxy to relays. If a ruleset download fails due to a proxy, and if your agents require a proxy to access the relay or manager, then you must either:

- [update agents' software](#), then [configure the proxy](#)
 - bypass the proxy
 - add a relay and then select **Serve Application Control rulesets from relays**
- If you are using shared or global rulesets, a relay can result in faster performance.
 - If you are using local rulesets, a relay can cause slower performance,

- Do not use a relay with multi-tenant configurations when non-primary tenants (tN) use the default, primary (t0) relay group.

Configure events and alerts

About Deep Security event logging

Deep Security Agents record when a protection module rule or condition is triggered (a "security event"). Agents and Deep Security Manager also records when administrative or system-related events occur (a "system event"), such as an administrator logging in, or agent software being upgraded. Event data is used to populate the various reports and graphs in Deep Security Manager.

To view events, go to **Events & Reports** in Deep Security Manager.

Where are event logs on the agent?

Location varies by the computer's operating system. On Windows, event logs are stored in this location:

```
C:\Program Data\Trend Micro\Deep Security Agent\Diag
```

On Linux, event logs are stored here:

```
/var/opt/ds_agent/diag
```

Note: These locations only contain standard-level logs; diagnostic debug-level logs have a different location. For performance reasons, debug-level logging is not enabled by default. You should only enable debug logging if diagnosing an issue with Trend Micro technical support, and make sure to disable debug logging when you are done. For more information, see [Enabling detailed logging on Deep Security Agent \(DSA\)](#).

When are events sent to the manager?

Most events that take place on a computer are sent to the Deep Security Manager during the next heartbeat operation except the following, which will be sent right away if communication settings allow relays/agents/appliances to initiate communication:

- Smart Scan Server is offline
- Smart Scan Server is back online
- Integrity Monitoring scan is complete
- Integrity Monitoring baseline created
- Unrecognized elements in an Integrity Monitoring Rule
- Elements of an Integrity Monitoring Rule are unsupported on the local platform
- Abnormal restart detected
- Low disk space warning
- Log Inspection offline
- Log Inspection back online
- Reconnaissance scan detected (if the setting is enabled in **Computer or Policy editor**¹ > **Firewall > Reconnaissance**)

How long are events stored?

Once collected by the Deep Security Manager, events are kept for a period of time, which is specified on the **Administration > System Settings > Storage** page. For details, see "[Log and event storage best practices](#)" on page 1129.

System events

All the Deep Security system events are listed and can be configured on the **Administration > System Settings > System Events** tab. You can set whether to record the individual events and whether to forward them to a SIEM system. For details on system events, see "[System events](#)" on page 1298.

Security events

Each protection module generates events when rules are triggered or other configuration conditions are met. Some of this security event generation is configurable. For information on specific types of security events, refer to these articles:

¹You can change these settings for a policy or for a specific computer. To change the settings for a policy, go to the Policies page and double-click the policy that you want to edit (or select the policy and click Details). To change the settings for a computer, go to the Computers page and double-click the computer that you want to edit (or select the computer and click Details).

- ["Anti-malware events" on page 1350](#)
- ["View and restore identified malware" on page 856](#)
- ["Application Control events" on page 1349](#)
- ["Firewall events" on page 1353](#)
- ["Integrity monitoring events" on page 1367](#)
- ["Intrusion prevention events" on page 1361](#)
- ["Log inspection events" on page 1371](#)
- ["Web reputation events" on page 1372](#)
- ["Device Control events" on page 1352](#)

The firewall stateful configuration in effect on a computer can be modified to enable or disable TCP, UDP, and ICMP event logging. To edit the properties of a stateful firewall configuration, go to **Policies > Common Objects > Other > Firewall Stateful Configurations**. The logging options are in the **TCP**, **UDP**, and **ICMP** tabs of the firewall stateful configuration's **Properties** window. For more information about firewall events, see ["Firewall events" on page 1353](#).

See the events associated with a policy or computer

The **Policy editor**¹ and the **Computer editor**² both have **Events** tabs for each protection module. The policy editor displays events associated with the current policy. The computer editor displays events specific to the current computer.

View details about an event

To see details about an event, double-click it.

The **General** tab displays:

- **Time:** The time according to the system clock on the computer hosting the Deep Security Manager.
- **Level:** The severity level of event that occurred. Event levels include **Info**, **Warning**, and **Error**.
- **Event ID:** The event type's unique identifier.

¹To open the Policy editor, go to the Policies page and double-click the policy that you want to edit (or select the policy and click Details).

²To open the Computer editor, go to the Computers page and double-click the computer that you want to edit (or select the computer and click Details).

- **Event:** The name of the event (associated with the event ID.)
- **Target:** The system object associated with the event will be identified here. Clicking the object's identification will display the object's properties sheet.
- **Event Origin:** The Deep Security component from which the event originated.
- **Action Performed By:** If the event was initiated by a user, that user's username will be displayed here. Clicking the username will display the **User Properties** window.
- **Manager:** The hostname of the Deep Security Manager computer.
- **Description:** If appropriate, the specific details of what action was performed to trigger this event are displayed here.

The **Tags** tab displays tags that have been attached to this event. For more information on event tagging, see **Policies > Common Objects > Other > Tags**, and "[Apply tags to identify and group events](#)" on page 1136.

Filter the list to search for an event

The **Period** toolbar lets you filter the list to display only those events that occurred within a specific timeframe.

The **Computers** toolbar lets you organize the display of event log entries by computer groups or computer policies.

Clicking **Search > Open Advanced Search** toggles the display of the advanced search bar.

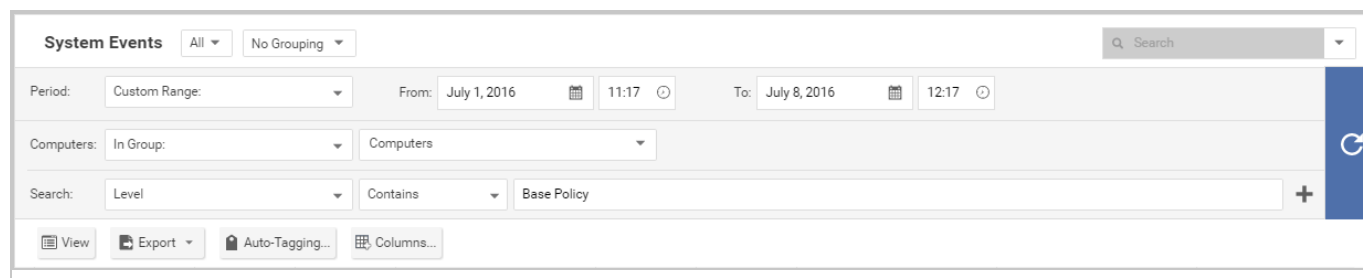

Clicking the "Add Search Bar" button (+) to the right of the search bar will display an additional search bar so you can apply multiple parameters to your search. When you are ready, press the "Submit Request" button (at the right of the toolbars with the right-arrow on it).

Export events

You can export displayed events to a CSV file. (Paging is ignored, all pages will be exported.) You have the option of exporting the displayed list or the selected items.

Improve logging performance

Here are some suggestions to help maximize the performance of event collection:

- Reduce or disable log collection for computers that are not of interest.
- Consider reducing the logging of firewall rule activity by disabling some logging options in the firewall stateful configuration **Properties** window. For example, disabling the UDP logging will eliminate the "Unsolicited UDP" log entries.

Log and event storage best practices

Best practices for log and event data storage depend on the data compliance regulations you must meet, such as PCI and HIPAA. Also consider optimizing the use of your database. Storing too much data may affect database performance and size requirements.

If you're storing too much data in your database, these symptoms may occur:

- Error messages that systems may be experiencing loss of database activity
- Inability to import software updates
- General slow-down in Deep Security

To avoid those symptoms:

1. Store system events according to the compliance standard requirement.
2. Forward system and security events to external storage. See ["Forward Deep Security events to a Syslog or SIEM server" on page 1146](#). Then you can reduce how long events are kept in the local database.
3. Set thresholds in the log inspection module for event storage or event forwarding. **Severity clipping** allows you to send events to a Syslog server (if enabled) or to store events based on the severity level of the log inspection rule. See ["Configure log inspection event forwarding and storage" on page 1042](#).

Default local storage settings are in the table below. To change these settings, go to **Administration > System Settings > Storage**. To delete software versions or older rule updates, go to **Administration > Updates > Software > Local** or **Administration > Updates > Security > Rules**.

Tip: To reduce database disk space usage, forward events to an external Syslog server or SIEM and reduce the local event retention time. Only keep counters locally.

Data type settings	Data pruning default setting
Automatically delete Anti-Malware Events older than	7 Days
Automatically delete Web Reputation Events older than:	7 Days
Automatically delete Firewall Events older than:	7 Days
Automatically delete Intrusion Prevention Events older than:	7 Days
Automatically delete Integrity Monitoring Events older than:	7 Days
Automatically delete Log Inspection Events older than:	7 Days
Automatically delete Application Control Events older than:	7 Days
Automatically delete Device Control Events older than:	7 Days
Automatically delete System Events older than:	53 Weeks
Automatically delete Server Logs older than:	7 Days
Automatically delete Counters older than:	13 Weeks
Number of older software versions to keep per platform:*	5
Number of older Rule Updates to keep:	10

* If multi-tenancy is enabled, this setting will not be available.

Note: If using a PostgreSQL database, old events might not be pruned immediately. PostgreSQL maintenance jobs periodically remove the old events' database partitions. Pruning will occur during the next scheduled job.

Events are records of individual events. They populate the **Events** pages.

Counters are the number of times individual events have occurred. They populate the dashboard widgets (number of firewall events over the last 7 days, etc.) and the reports.

Server log files are from Deep Security Manager's web server. They don't include event logs from agents installed on your network's web servers.

Troubleshooting

During troubleshooting, it may be useful to increase the logging level and record more detailed events.

Increased logging can significantly increase disk space usage. Reduce the logging level again when you have finished troubleshooting.

1. Open the **Computer or Policy editor**¹.
2. Go to **Settings > General > Logging Level**.
3. Choose whether to inherit the logging override settings from the policy assigned to this computer (**Inherited**), to not override logging settings (**Do Not Override**), to log all triggered firewall rules (**Full Firewall Event Logging**), to log all triggered intrusion prevention rules (**Full Intrusion Prevention Event Logging**), or to log all triggered rules (**Full Logging**).
4. Click **Save** .

Limit log file sizes

You can set the maximum size of each individual log file and how many of the most recent files are kept. Event log files will be written to until they reach the maximum allowed size, at which point a new file will be created and written to until it reaches the maximum size and so on. Once the maximum number of files is reached, the oldest will be deleted before a new file is created. Event log entries usually average around 200 bytes in size and so a 4 MB log file will hold about 20,000 log entries. How quickly your log files fill up depends on the number of rules in place.

¹You can change these settings for a policy or for a specific computer. To change the settings for a policy, go to the Policies page and double-click the policy that you want to edit (or select the policy and click Details). To change the settings for a computer, go to the Computers page and double-click the computer that you want to edit (or select the computer and click Details).

1. Open the **Computer or Policy editor**¹ for the policy that you want to configure.
2. Go to **Settings > Advanced > Events**.
3. Configure these properties:
 - **Maximum size of the event log files (on Agent/Appliance):** Maximum size that the log file can reach before a new log file is created.
 - **Number of event log files to retain (on Agent/Appliance):** Maximum number of log files that will be kept. Once the maximum number of log files is reached, the oldest file will be deleted before a new one is created.
 - **Do Not Record Events with Source IP of:** This option is useful if you don't want Deep Security to make record events for traffic from certain trusted computers.

Note: The following three settings let you fine tune event aggregation. To save disk space, Deep Security Agents and Appliances will take multiple occurrences of identical events and aggregate them into a single entry and append a "repeat count", a "first occurrence" timestamp, and a "last occurrence" timestamp. To aggregate event entries, Deep Security Agents and Appliances need to cache the entries in memory and then write them to disk.

- **Cache Size:** Determines how many types of events to track at any given time. Setting a value of 10 means that 10 types of events will be tracked (with a repeat count, first occurrence timestamp, and last occurrence timestamp). When a new type of event occurs, the oldest of the 10 aggregated events will be flushed from the cache and written to disk.
- **Cache Lifetime:** Determines how long to keep a record in the cache before flushing it to disk. If this value is 10 minutes and nothing else causes the record to be flushed, any record that reaches an age of 10 minutes gets flushed to disk.
- **Cache Stale time:** Determines how long to keep a record whose repeat count has not been recently incremented. If Cache Lifetime is 10 minutes and Cache Staletime is 2 minutes, an event record which has gone 2 minutes without being incremented will be flushed and written to disk.

¹You can change these settings for a policy or for a specific computer. To change the settings for a policy, go to the Policies page and double-click the policy that you want to edit (or select the policy and click Details). To change the settings for a computer, go to the Computers page and double-click the computer that you want to edit (or select the computer and click Details).

Note: Regardless of the above settings, the cache is flushed whenever events are sent to the Deep Security Manager.

4. Click **Save**.

Event logging tips

- On computers that are less important, modify the amount of logs collected. This can be done in the **Events** and **Advanced Network Engine Options** areas on the **Computer or Policy editor**¹ > **Settings** > **Advanced** tab.
- Consider reducing the event logging of firewall rule activity by disabling the event logging options in the firewall stateful configuration. (For example, if you disable UDP logging, it will eliminate unsolicited UDP log entries.)
- For intrusion prevention rules, the best practice is to log only dropped packets. If you log packet modifications, it may cause too many log entries.
- For intrusion prevention rules, only include packet data (an option in the intrusion prevention rule's **Properties** window) when you are interested in examining the behavior of a specific attack. Packet data increases log sizes, so it shouldn't be used for everything.

Anti-Malware scan failures and cancellations

Anti-Malware scans can fail or be cancelled for several reasons, which have different recommended actions.

Note: These events can occur for manual, quick, or scheduled scans.

Anti-Malware scan failure events

This table provides possible reasons for system events 793, 795, and 1543 (Malware Scan Failure).

¹You can change these settings for a policy or for a specific computer. To change the settings for a policy, go to the Policies page and double-click the policy that you want to edit (or select the policy and click Details). To change the settings for a computer, go to the Computers page and double-click the computer that you want to edit (or select the computer and click Details).

Event reason	Reason ID *	Description	Recommended action
Empty configuration	31	Malware Scan could not be started. This is caused by an empty Malware Scan configuration.	<ol style="list-style-type: none"> 1. From the Computer or Policy editor, go to Anti-Malware > General. 2. Make sure a Malware Scan configuration is assigned to the Scheduled scan. 3. Rerun the scan.
Anti-Malware module is off	30	Malware Scan could not be started. This is because the Anti-Malware module is turned off.	<ol style="list-style-type: none"> 1. From the Computer or Policy editor, go to Anti-Malware > General. 2. Make sure the Anti-Malware state is "On" or "Inherited (On)." 3. Rerun the scan.
Anti-Malware service stops	7	Malware Scan failed because the Anti-Malware service is being terminated.	<ol style="list-style-type: none"> 1. From the Computer or Policy editor, go to Overview > General, and click Check Status. 2. If the Anti-Malware Status is "Anti-Malware Engine Offline," follow the procedure to solve the "Error: Anti-Malware Engine Offline" on page 1379 issue. 3. Rerun the scan.
Anti-Malware engine is offline	9	Malware Scan failed because the Anti-Malware engine is offline.	<ol style="list-style-type: none"> 1. Follow the procedure to solve the "Error: Anti-Malware Engine Offline" on page 1379 issue. 2. Rerun the scan.
Fail to access configuration	-2	Malware Scan failed because of an inaccessible Anti-Malware configuration. (This may be due to an unexpected internal error or timing issue.)	<ol style="list-style-type: none"> 1. From the Computers page, right-click the target computer and go to Actions > Assign Policy. 2. Rerun the scan.
Other scan task is	-16	Malware Scan failed because another scan task is in progress.	<ol style="list-style-type: none"> 1. From the Computers page,

Event reason	Reason ID *	Description	Recommended action
running		(This may be due to an unexpected internal error or timing issue.)	<p>check the Task(s) column for the target computer to see if another Malware Scan is in progress.</p> <ol style="list-style-type: none"> If yes, either wait for the current scan task to complete or right-click the target computer and go to Actions > Cancel Malware Scan. Rerun the scan.
Unknown reason on agent	10	Malware Scan failed for an unknown reason.	<ol style="list-style-type: none"> Collect the system event information and follow the procedure to "Create a diagnostic package and logs" on page 1951. Contact support.

* The reason ID is included in events forwarded to an external Syslog, SIEM server, or to Amazon SNS. It is not displayed in Deep Security Manager.

Anti-Malware scan cancellation events

This table provides possible reasons for system events 1526, 1528, and 1540 (Malware Scan Cancellation Completed).

Event reason	Reason ID *	Description	Recommended action
Cancel by user	1	Anti-Malware scan was canceled manually.	Run the scan again.
Server reboot	32	Anti-Malware scan was canceled, possibly because the computer being scanned was shut down or restarted.	Check that the computer is on and run the scan again.
Anti-Malware service restart	7	Anti-Malware scan was cancelled because the Anti-Malware service was being restarted.	<ol style="list-style-type: none"> From the Computer or Policy editor, go to Anti-Malware > General. Make sure the Anti-Malware state is "On" or "Inherited (On)."

Event reason	Reason ID *	Description	Recommended action
			3. Rerun the scan.
Deep Security Agent restart	6	Anti-Malware scan was cancelled because the agent was being restarted. Check that the Anti-Malware module is online and run the scan again.	<ol style="list-style-type: none"> 1. From the Computer or Policy editor, go to Anti-Malware > General. 2. Make sure the Anti-Malware state is "On" or "Inherited (On)." 3. Rerun the scan. <p>Also make sure there is no agent upgrade or policy change taking place during scanning because these tasks may cause the agent to restart.</p>
Unknown reason	-1	Anti-Malware scan was cancelled for an unknown reason.	<ol style="list-style-type: none"> 1. Collect the system event information and follow the procedure to "Create a diagnostic package and logs" on page 1951. 2. Contact support.

* The reason ID is included in events forwarded to an external Syslog, SIEM server, or to Amazon SNS. It is not displayed in Deep Security Manager.

Apply tags to identify and group events

Deep Security enables you to create tags that you can use to identify and sort events. For example, you might use tags to separate events that are benign from those that require further investigation. You can use tags to create customized dashboards and reports.

Although you can use event tagging for a variety of purposes, it was designed to ease the burden of event management. After you have analyzed an event and determined that it is benign, you can look through the event logs of the computer (and any other similarly configured and tasked computers) to find similar events and apply the same label to them, eliminating the need to analyze each event individually.

To view tags that are currently in use, go to **Policies > Common Objects > Other > Tags**.

Note: Tags do not alter the data in the events themselves, nor do they allow users to delete events. They are simply extra attributes provided by the manager.

You can perform tagging the following ways:

- ["Manual tagging" below](#) lets you tag specific events as needed.
- ["Auto-tagging" below](#) lets you use an existing event as the model for auto-tagging similar events on the same or other computers. You define the parameters for "similarity" by selecting which event attributes have to match the model event attributes for a tag to be applied.
- ["Trusted source tagging" on page 1139](#) lets you auto-tag integrity monitoring events based on their similarity to known-good events from a trusted source.

Note: An important difference between standard tagging and trusted source tagging is that "Run on Existing Events Now" can only be done with standard event tagging

Manual tagging

1. Go to **Events & Reports > Events** and select an event list. Right-click the event (or select multiple events and right-click) and select **Add Tag(s)**.
2. Type a name for the tag. Deep Security Manager will suggest matching names of existing tags as you type.
3. Select **The Selected [Event Type] Event**. Click **Next**.
4. Enter some optional comments and click **Finish**.

In the events list, you can see your tag in the **TAG(S)** column.

Auto-tagging

Deep Security Manager enables you to define rules that apply the same tag to similar events automatically. To view existing saved auto-tagging rules, click **Auto-Tagging** in the menu bar on any **Events** page. You can run saved rules manually from this page.

1. Go to **Events & Reports > Events** and select an event list. Right-click a representative event and select **Add Tag(s)**.
2. Type a name for the tag. Deep Security Manager will suggest matching names of existing tags as you type.
3. Select **Apply to selected and similar [Event Type] Events** and click **Next**.

4. Select the computers where you want to auto-tag events and click **Next**. When applying tags to system events, this page is skipped.
5. Select which attributes will be examined to determine whether events are similar. For the most part, the attribute options are the same as the information displayed in the columns of the **Events** list pages. When you have selected which attributes to include in the event selection process, click **Next**.
6. On the next page, specify when events should be tagged. If you select **Existing [Event Type] Events**, you can select **Apply Auto-Tag Rule now** to apply the auto-tagging rule immediately, or **Apply Auto-Tag Rule in the background** to have it run in the background at a lower priority. Select **Future [Event Type] Events** to apply the auto-tagging rule to events that will happen in the future. You can also save the auto-tagging rule by selecting **Save Auto-Tag Rule** and optionally entering a name. Click **Next**.
7. Review the summary of your auto-tagging rule and click **Finish**.

In the events list, you can see that your original event and all similar events have been tagged

Note: Event tagging only occurs after events have been retrieved from the agents or appliances to the Deep Security Manager database.

Set the precedence for an auto-tagging rule

Once an auto-tagging rule is created, you can assign it a **Precedence** value. If the auto-tagging rule has been configured to run on future events, the rule's precedence determines the order in which all auto-tagging rules are applied to incoming events. For example, you can have a rule with a precedence value of "1" that tags all "User Signed In" events as "suspicious", and a rule with a precedence value of "2" that removes the "suspicious" tag from all "User Signed In" events where the target (user) is you. This will result in a "suspicious" tag being applied to all future "User Signed In" events where the user is not you.

1. In an events list, click **Auto-Tagging** to display a list of saved auto-tagging rules.
2. Right-click an auto-tagging rule and select **Details**.
3. In the **General** tab, select a **Precedence** for the rule.

Auto-tagging log inspection events

Log inspection events are auto-tagged based upon their grouping in the log file structure. This simplifies and automates the processing of log inspection events within Deep Security Manager. You can use auto-tagging to automatically apply tags for the log inspection groups. Log inspection rules have groups associated with them in the rules. For example:

```
<rule id="18126" level="3">  
<if_sid>18101</if_sid>
```

```

<id>^20158</id>
<description>Remote access login success</description>
<group>authentication_success,</group>
</rule>

<rule id="18127" level="8">
<if_sid>18104</if_sid>
<id>^646|^647</id>
<description>Computer account changed/deleted</description>
<group>account_changed,</group>
</rule>

```

Each group name has a "friendly" name string associated with it. In the above example, "authentication_success" would be "Authentication Success", "account_changed" would be "Account Changed". When this checkbox is set, the friendly names are automatically added as a tag for that event. If multiple rules trigger, multiple tags will be attached to the event.

Trusted source tagging

Note: Trusted source event tagging can only be used with events generated by the integrity monitoring protection module.

The integrity monitoring module allows you to monitor system components and associated attributes on a computer for changes. ("Changes" include creation and deletion as well as edits.) Among the components that you can monitor for changes are files, directories, groups, installed software, listening port numbers, processes, registry keys, and so on.

Trusted source event tagging is designed to reduce the number of events that need to be analyzed by automatically identifying events associated with authorized changes.

In addition to auto-tagging similar events, the integrity monitoring module allows you to tag events based on their similarity to events and data found on **Trusted Sources**. A trusted source can be either:

1. A **local trusted computer**,
2. The **Trend Micro Certified Safe Software Service**, or
3. A **trusted common baseline**, which is a set of file states collected from a group of computers.

Local trusted computer

A trusted computer is a computer that will be used as a "model" computer that you know will only generate benign or harmless events. A "target" computer is a computer that you are monitoring for unauthorized or unexpected changes. The auto-tagging rule examines events on target computers and compares them to events from the trusted computer. If any events match, they are tagged with the tag defined in the auto-tagging rule.

You can establish auto-tagging rules that compare events on protected computers to events on a trusted computer. For example, a planned rollout of a patch can be applied to the trusted computer. The events associated with the application of the patch can be tagged as "Patch X". Similar events raised on other systems can be auto-tagged and identified as acceptable changes and filtered out to reduce the number of events that need to be evaluated.

How does Deep Security determine whether an event on a target computer matches an event on a trusted source computer?

Integrity monitoring events contain information about transitions from one state to another. In other words, events contain *before* and *after* information. When comparing events, the auto-tagging engine will look for matching before and after states; if the two events share the same before and after states, the events are judged to be a match and a tag is applied to the second event. This also applies to creation and deletion events.

Note: Remember that when using a trusted computer for trusted source event tagging, the events being tagged are events generated by integrity monitoring rules. This means that the integrity monitoring rules that are generating events on the target computer must also be running on the trusted source computer.

Note: Trusted source computers must be scanned for malware before applying trusted source event tagging.

Note: Utilities that regularly make modifications to the content of files on a system (prelinking on Linux, for example) can interfere with trusted source event tagging.

Tag events based on a local trusted computer

1. Make sure the trusted computer is free of malware by running a full anti-malware scan.
2. Make sure the computer(s) on which you want to auto-tag events are running the same (or some of the same) integrity monitoring rules as the trusted source computer.

3. In Deep Security Manager, go to **Events & Reports > Integrity Monitoring Events** and click **Auto-Tagging** in the toolbar.
4. In the **Auto-Tag Rules (Integrity Monitoring Events)** window, click **New Trusted Source** to display the **Tag Wizard**.
5. Select **Local Trusted Computer** and click **Next**.
6. From the list, select the computer that will be the trusted source and click **Next**.
7. Specify one or more tags to apply to events on target computers when they match events on this trusted source computer. Click **Next**.

Note: You can enter the text for a new tag or select from a list of existing tags.

8. Identify the target computers whose events will be matched to those of the trusted source. Click **Next**.
9. Optionally, give the rule a name and click **Finish**.

Tag events based on the Trend Micro Certified Safe Software Service

The Certified Safe Software Service is an allow list of known-good file signatures maintained by Trend Micro. This type of trusted source tagging will monitor target computers for file-related integrity monitoring events. When an event has been recorded, the file's signature (after the change) is compared to Trend Micro's list of known good file signatures. If a match is found, the event is tagged.

1. In Deep Security Manager, go to **Events & Reports > Integrity Monitoring Events** and click **Auto-Tagging** in the toolbar.
2. In the **Auto-Tag Rules (Integrity Monitoring Events)** window, click **New Trusted Source** to display the **Tag Wizard**.
3. Select **Certified Safe Software Service** and click **Next**.
4. Specify one or more tags to apply to events on target computers when they match the Certified Safe Software Service. Click **Next**.
5. Identify the target computers whose events will be matched to the Certified Safe Software Service. Click **Next**.
6. Optionally, give the rule a name and click **Finish**.

Tag events based on a trusted common baseline

The trusted common baseline method compares events within a group of computers. A group of computers is identified and a common baseline is generated based on the files and system states targeted by the integrity monitoring rules in effect on the computers in the group. When an integrity monitoring event occurs on a computer within the group, the signature of the file after the change is compared to the common baseline. If the file's new signature has a match elsewhere

in the common baseline, a tag is applied to the event. In trusted computer method, the before and after states of an integrity monitoring event are compared, but in the trusted common baseline method, only the after state is compared.

Note: This method relies on all the computers in the common group being secure and free of malware. A full anti-malware scan should be run on all the computers in the group before the common baseline is generated.

Note: When an integrity monitoring baseline is generated for a computer, Deep Security will first check if that computer is part of a trusted common baseline group. If it is, it will include the computer's baseline data in the trusted common baseline for that group. For this reason, the trusted common baseline auto-tagging rule must be in place before any integrity monitoring rules have been applied to the computers in the common baseline group.

1. Make sure all the computers that will be in the group that will make up the trusted common baseline are free of malware by running a full anti-malware scan on them.
2. In Deep Security Manager, go to **Events & Reports > Integrity Monitoring Events** and click **Auto-Tagging** in the toolbar.
3. In the **Auto-Tag Rules (Integrity Monitoring Events)** window, click **New Trusted Source** to display the **Tag Wizard**.
4. Select **Trusted Common Baseline** and click **Next**.
5. Specify one or more tags to apply to events when they have a match in the trusted common baseline and click **Next**.
6. Identify the computers to include in the group used to generate the trusted common baseline. Click **Next**.
7. Optionally, give this rule a name and click **Finish**.

Delete a tag

1. In an events list, right-click the events with the tag you want to delete, and select **Remove Tag(s)**.
2. Select the tag you'd like to remove. Choose to remove the tag from **The Selected [Event Type] Event** or to **Apply to selected similar [Event Type] Events**. Click **Next**.
3. Enter some optional comments and click **Finish**.

Reduce the number of logged events

To reduce the number of events being logged, the Deep Security Manager can be configured to operate in one of several **Advanced Logging Policy** modes. These modes are set in the **Computer or Policy editor**¹ on the **Settings > Advanced > Advanced Network Engine Settings** area.

The following table lists the types of events that are ignored in four of the more complex Advanced Logging Policy modes:

Mode	Ignored Events
Stateful and Normalization Suppression	Out Of Connection Invalid Flags Invalid Sequence Invalid ACK Unsolicited UDP Unsolicited ICMP Out Of Allowed Policy Dropped Retransmit
Stateful, Normalization, and Frag Suppression	Out Of Connection Invalid Flags Invalid Sequence Invalid ACK Unsolicited UDP Unsolicited ICMP Out Of Allowed Policy CE Flags Invalid IP Invalid IP Datagram Length Fragmented Invalid Fragment Offset First Fragment Too Small Fragment Out Of Bounds Fragment Offset Too Small IPv6 Packet Max Incoming Connections Max Outgoing Connections Max SYN Sent License Expired IP Version Unknown Invalid Packet Info Maximum ACK Retransmit

¹You can change these settings for a policy or for a specific computer. To change the settings for a policy, go to the Policies page and double-click the policy that you want to edit (or select the policy and click Details). To change the settings for a computer, go to the Computers page and double-click the computer that you want to edit (or select the computer and click Details).

Mode	Ignored Events
	Packet on Closed Connection Dropped Retransmit
Stateful, Frag, and Verifier Suppression	Out Of Connection Invalid Flags Invalid Sequence Invalid ACK Unsolicited UDP Unsolicited ICMP Out Of Allowed Policy CE Flags Invalid IP Invalid IP Datagram Length Fragmented Invalid Fragment Offset First Fragment Too Small Fragment Out Of Bounds Fragment Offset Too Small IPv6 Packet Max Incoming Connections Max Outgoing Connections Max SYN Sent License Expired IP Version Unknown Invalid Packet Info Invalid Data Offset No IP Header Unreadable Ethernet Header Undefined Same Source and Destination IP Invalid TCP Header Length Unreadable Protocol Header Unreadable IPv4 Header Unknown IP Version Maximum ACK Retransmit Packet on Closed Connection Dropped Retransmit
Tap Mode	Out Of Connection Invalid Flags Invalid Sequence Invalid ACK Maximum ACK Retransmit Packet on Closed Connection Dropped Retransmit

Rank events to quantify their importance

The ranking system provides a way to quantify the importance of events. By assigning "asset values" to computers, and assigning severity or risk values to rules, the importance ("rank") of an event is calculated by multiplying the two values together. This allows you to sort events by rank.

Note: Unlike the other modules, Anti-Malware does not use asset values to rank event importance.

Web Reputation event risk values

Risk values for Web Reputation events are linked to the three levels of risk used by the Web Reputation settings on the **General** tab of the **Web Reputation** page:

- **Dangerous:** corresponds to "A URL that has been confirmed as fraudulent or a known source of threats."
- **Highly Suspicious:** corresponds to "A URL that is suspected to be fraudulent or a known source of threats."
- **Suspicious:** corresponds to "A URL that is associated with spam or possibly compromised."
- **Blocked by Administrator:** A URL that is on the Web Reputation Service **Blocked** list.
- **Untested:** A URL that does not have a risk level.

Firewall rule severity values

Severity values for Firewall rules are linked to their actions: Deny, Log Only, and Packet Rejection. (The latter refers to packets rejected because of a Firewall stateful configuration setting.) Use this panel to edit the severity values which will be multiplied by a computer's asset value to determine the rank of a Firewall event. (A Firewall rule's actions can be viewed and edited in the rule's **Properties** window.)

Intrusion Prevention rule severity values

Intrusion Prevention rule severity values are linked to their severity levels: Critical, High, Medium, Low, or Error. Use this panel to edit their values which will be multiplied by a computer's asset value to determine the rank of an Intrusion Prevention event. An Intrusion Prevention rule's severity setting can be viewed in the rule's **Properties** window.

Integrity Monitoring rule severity values

Integrity Monitoring rule severity values are linked to their severity levels: Critical, High, Medium, or Low. Use this panel to edit their values which will be multiplied by a computer's asset value to determine the rank of an Integrity Monitoring event. An Integrity Monitoring rule's severity can be viewed in the rule's **Properties** window.

Log Inspection rule severity values

Log Inspection rule severity values are linked to their severity levels: Critical, High, Medium, or Low. Use this panel to edit their values which will be multiplied by a computer's asset value to determine the rank of a Log Inspection event. A Log Inspection rule's severity level can be viewed and edited from the rule's **Properties** window.

Asset values

Asset values are not associated with any of their other properties like Intrusion Prevention rules or Firewall rules. Instead, asset values are properties in themselves. A computer's asset value can be viewed and edited from the computer's **Details** window. To simplify the process of assigning asset values, you can predefine some values that will appear in the **Asset Importance** list in the first page of the computer's **Details** window. To view existing predefined computer asset values, click the **View Asset Values** button in this panel. The **Asset Values** window displays the predefined settings. These values can be changed, and new ones can be created. (New settings will appear in the list for all computers.)

Forward events to a Syslog or SIEM server

Forward Deep Security events to a Syslog or SIEM server

You can send events to an external Syslog or Security Information and Event Management (SIEM) server. This can be useful for centralized monitoring, custom reporting, or to free local disk space on Deep Security Manager.

Note: Even if you enable event forwarding to an external server, Deep Security Manager still records system and security events locally in order to display them in reports and graphs. Therefore if you need to reduce disk space usage, event forwarding is not enough; you should also configure [how long to keep events locally](#).

Tip: Alternatively, if you want to publish events to Amazon SNS, see ["Set up Amazon SNS" on page 1214](#).

Basic steps include:

1. ["Allow event forwarding network traffic" below](#)
2. ["Request a client certificate" below](#)
3. ["Define a Syslog configuration" below](#)
4. ["Forward system events" on page 1150](#) and/or ["Forward security events" on page 1151](#)

Allow event forwarding network traffic

All routers, firewalls, and security groups must allow inbound traffic from Deep Security Manager (and, for direct forwarding of security events, inbound traffic from agents) to your Syslog server. See also ["Port numbers, URLs, and IP addresses" on page 410](#).

Request a client certificate

If you want to forward events securely (over TLS), and if your Syslog server requires client authentication, then you must generate a *client* (not server) certificate signing request (CSR). Deep Security Manager will use this certificate to identify and authenticate itself when it connects as a client to the Syslog server. For details on how to request a client certificate, contact your certificate authority (CA).

Note: Some Syslog servers do not accept self-signed server certificates (such as Deep Security Manager's default). A CA-signed, client certificate is required.

Use either a CA that the Syslog server trusts, or an intermediate CA whose certificate was signed, directly or indirectly, by a trusted root CA. (This is also called a "trust chain" or "signing chain".)

Once you receive the signed certificate from your CA, to upload it to Deep Security Manager, continue with ["Define a Syslog configuration" below](#).

Define a Syslog configuration

Syslog configurations define the destination and settings that can be used when forwarding system or security events.

If you configured SIEM or Syslog settings before January 26th, 2017, they have been converted to Syslog configurations. Identical configurations were merged.

1. Go to **Policies > Common Objects > Other > Syslog Configurations**.
2. Click **New > New Configuration**.
3. On the **General** tab, configure:

- **Name:** Unique name that identifies the configuration.
- **Description:** Optional description of the configuration.
- **Log Source Identifier:** Optional identifier to use instead of Deep Security Manager's hostname.

If Deep Security Manager is multi-node, each server node has a different hostname. Log source IDs can therefore be different. If you need the IDs to be the same regardless of hostname (for example, for filtering purposes), you can configure their shared log source ID here.

This setting does not apply to events sent directly by Deep Security Agent, which always uses its hostname as the log source ID.

- **Server Name:** Hostname or IP address of the receiving Syslog or SIEM server.
- **Server Port:** Listening port number on the SIEM or Syslog server. For UDP, the IANA standard port number is 514. For TLS, it's usually port 6514. See also "[Port numbers, URLs, and IP addresses](#)" on page 410.
- **Transport:** Whether the transport protocol is secure (TLS) or not (UDP).

With UDP, Syslog messages are limited to 64 KB. If the message is longer, data may be truncated.

With TLS, the manager and Syslog server must trust each other's certificates. The connection from the manager to the Syslog server is encrypted with TLS 1.2, 1.1, or 1.0.

Note:

TLS requires that you set **Agents should forward logs to Via the Deep Security Manager** (indirectly). Agents do not support forwarding with TLS.

- **Event Format:** Whether the log message's format is LEEF, CEF, or basic Syslog. See

["Syslog message formats" on page 1153](#)

Note: LEEF format requires that you set **Agents should forward logs to Via the Deep Security Manager** (indirectly).

Note: Basic Syslog format is not supported by Deep Security Anti-Malware, Web Reputation, Integrity Monitoring, and Application Control.

- **Include time zone in events:** Whether to add the full date (including year and time zone) to the event.

Example (selected): 2018-09-14T01:02:17.123+04:00.

Example (deselected): Sep 14 01:02:17.

Note: Full dates require that you set **Agents should forward logs to Via the Deep Security Manager** (indirectly).

- **Facility:** Type of process that events will be associated with. Syslog servers may prioritize or filter based upon a log message's facility field. See also [What are Syslog Facilities and Levels?](#)
- **Agents should forward logs:** Whether to send events **Directly to the Syslog server or Via the Deep Security Manager** (indirectly).

When forwarding logs directly to the Syslog server, agents use clear text UDP. Logs contain sensitive information about your security system. If logs will travel over an untrusted network such as the Internet, consider adding a VPN tunnel or similar to prevent reconnaissance and tampering.

Note: If you forward logs via the manager, they do not include Firewall and Intrusion Prevention packet data unless you configure Deep Security Manager to include it. For instructions, see [Sending packet data to syslog via Deep Security Manager \(DSM\)](#).

4. If the Syslog or SIEM server requires TLS clients to do client authentication (also called bilateral or mutual authentication; see ["Request a client certificate" on page 1147](#)), then on the **Credentials** tab, configure:

- **Private Key:** Paste the private key of Deep Security Manager's client certificate.
- **Certificate:** Paste the **client** certificate that Deep Security Manager will use to identify itself in TLS connections to the Syslog server. Use PEM, also known as Base64-encoded format.
- **Certificate Chain:** If an intermediate CA signed the client certificate, but the Syslog server doesn't know and trust that CA, then paste CA certificates which prove a relationship to a trusted root CA. Press Enter between each CA certificate.

5. Click **Apply**.

6. If you selected the TLS transport mechanism, verify that both Deep Security Manager and the Syslog server can connect and trust each other's certificates.

a. Click **Test Connection**.

Deep Security Manager tries to resolve the hostname and connect. If that fails, an error message appears.

If the Syslog or SIEM server certificate is not yet trusted by Deep Security Manager, the connection fails and an **Accept Server Certificate?** message should appear. The message shows the contents of the Syslog server's certificate.

b. Verify that the Syslog server's certificate is correct, and then and click **OK** to accept it.

The certificate is added to the manager's list of trusted certificates on **Administration > System Settings > Security**. Deep Security Manager can accept self-signed certificates.

c. Click **Test Connection** again.

Now the TLS connection should succeed.

7. Continue by selecting which events to forward. See "[Forward system events](#)" below and/or "[Forward security events](#)" on the next page.

Forward system events

Deep Security Manager generates system events (such as administrator logins or upgrading agent software).

1. Go to **Administration > System Settings > Event Forwarding**.
2. From **Forward System Events to a remote computer (via Syslog) using configuration**, either select an existing configuration or select **New**. For details, see "[Define a Syslog](#)

[configuration" on page 1147.](#)

3. Click **Save**.

Note: If Deep Security Manager is multi-node, system events are only sent from one node to avoid duplicates.

Forward security events

Deep Security Agent protection features generate security events (such as detecting malware or triggering an IPS rule). You can forward events either:

- Directly
- Indirectly, via Deep Security Manager

[Some event forwarding options](#) require forwarding agent events indirectly, via Deep Security Manager.

Like other policy settings, you can override event forwarding settings for specific policies or computers. See ["Policies, inheritance, and overrides" on page 701.](#)

1. Go to **Policies**.
2. Double-click the policy used by the computers.
3. Select **Settings** and then the **Event Forwarding** tab.
4. From **Period between sending of events**, select how often to forward events.
5. From **Anti-Malware Syslog Configuration** and other protection modules' drop-down menus, either select which Syslog configuration to use, click **Edit** to change it, select **None** to disable it, or click **New**. For details, see ["Define a Syslog configuration" on page 1147.](#)
6. Click **Save**.

Troubleshoot event forwarding

"Failed to Send Syslog Message" alert

If there is a problem with your Syslog configuration, you might see this alert:

```
Failed to Send Syslog Message
The Deep Security Manager was unable to forward messages to a Syslog
Server.
Unable to forward messages to a Syslog Server
```

The alert also contains a link to the affected Syslog configuration. Click the link to open the configuration and then click **Test Connection** to get more diagnostic information. It will either

indicate that the connection was successful or display an error message with more details about the cause.

Can't edit Syslog configurations

If you can see the Syslog configurations but can't edit them, the role associated with your account might not have the appropriate rights. An administrator who is able to configure roles can check your permissions by going to **Administration > User Management**. Then select your name and click **Properties**. On the **Other Rights** tab, the **Syslog Configurations** setting controls your ability to edit Syslog configurations. For more information on users and roles, see ["Add and manage users" on page 1483](#).

Can't see the Syslog configuration sections of Deep Security Manager

If you can't see the Syslog configurations UI in Deep Security Manager, you may be a tenant in a multi-tenant environment where the primary tenant has disabled this feature or configured it for you.

Syslog not transferred due to an expired certificate

Valid certificates are required to connect securely via TLS. If you set up TLS client authentication and the certificate expires, messages are not sent to the Syslog server. To fix this problem, get a new certificate, update the Syslog configuration with the new certificate values, test the connection, and then save the configuration.

Syslog not delivered due to an expired or changed server certificate

Valid certificates are required to connect securely via TLS. If the Syslog server's certificate has expired or changed, open the Syslog configuration and click **Test Connection**. You are prompted to accept the new certificate.

Compatibility

Deep Security has been tested with the enterprise version of:

- Splunk 6.5.1
- IBM QRadar 7.2.8 Patch 3 (with the TLS protocol patch, PROTOCOL-TLSSyslog-7.2-20170104125004.noarch)
- HP ArcSight 7.2.2 (with a TLS Syslog-NG connector created using the ArcSight-7.2.2.7742.0-Connector tool)

Other standard Syslog software might work, but has not been verified.

Tip: If you are using Splunk, you can use the [Deep Security app for Splunk](#) to get dashboards and saved searches.

Syslog message formats

Common Event Format (CEF) and Log Event Extended Format (LEEF) log message formats are slightly different. For example, the "Source User" column in the GUI corresponds to a field named "suser" in CEF; in LEEF, the same field is named "usrName" instead. Log message fields also vary by whether the event originated on the Deep Security Agent or Manager and which feature created the log message.

Note: If your syslog messages are being truncated, it may be because you're using User Datagram Protocol (UDP). To prevent truncation, transfer your syslog messages over Transport Layer Security (TLS) instead. For instructions on switching to TLS, see "[Define a Syslog configuration](#)" on page 1147.

Note: Basic syslog format is not supported by the Anti-Malware, Web Reputation, Integrity Monitoring, and Application Control protection modules.

If the syslog messages are sent from the manager, there are several differences. In order to preserve the original Deep Security Agent hostname (the source of the event), a new extension ("dvc" or "dvchost") is present. "dvc" is used if the hostname is an IPv4 address; "dvchost" is used for hostnames and IPv6 addresses. Additionally, the extension "TrendMicroDsTags" is used if the events are tagged. (This applies only to auto-tagging with run on future, since events are forwarded via syslog only as they are collected by the manager.) The product for logs relayed through the manager will still read "Deep Security Agent"; however, the product version is the version of the manager.

CEF syslog message format

All CEF events include 'dvc=IPv4 Address' or 'dvchost=Hostname' (or the IPv6 address) for the purposes of determining the original Deep Security Agent source of the event. This extension is important for events sent from a Deep Security Virtual Appliance or Manager, since in this case the syslog sender of the message is not the originator of the event.

Base CEF format: CEF:Version|Device Vendor|Device Product|Device Version|Signature ID|Name|Severity|Extension

To determine whether the log entry comes from the Deep Security Manager or a Deep Security Agent, look at the "Device Product" field:

Sample CEF Log Entry: Jan 18 11:07:53 dsmhost CEF:0|Trend Micro|Deep Security Manager|<DSM version>|600|Administrator Signed In|4|user=Master...

Note: Events that occur on a VM that is protected by a virtual appliance, but that don't have an in-guest agent, will still be identified as coming from an agent.

To further determine what kind of rule triggered the event, look at the "Signature ID" and "Name" fields:

Sample Log Entry: Mar 19 15:19:15 root CEF:0|Trend Micro|Deep Security Agent|<DSA version>|123|Out Of Allowed Policy|5|cn1=1...

The "Signature ID" value indicates what kind of event has been triggered:

Signature IDs	Description
10	Custom Intrusion Prevention (IPS) rule
20	Log-only Firewall rule
21	Deny Firewall rule
30	Custom Integrity Monitoring rule
40	Custom Log Inspection rule
100-7499	System events
100-199	Policy Firewall rule and Firewall stateful configuration
200-299	IPS internal errors
300-399	SSL/TLS events
500-899	IPS normalization
1,000,000-1,999,999	Trend Micro IPS rule. The signature ID is the same as the IPS rule ID.
2,000,000-2,999,999	Integrity Monitoring rule. The signature ID is the Integrity Monitoring rule ID + 1,000,000.
3,000,000-3,999,999	Log Inspection rule. The signature ID is the Log Inspection rule ID + 2,000,000.
4,000,000-4,999,999	Anti-Malware events. Currently, only these signature IDs are used: <ul style="list-style-type: none"> • 4,000,000 - Anti-Malware - Real-Time Scan • 4,000,001 - Anti-Malware - Manual Scan • 4,000,002 - Anti-Malware - Scheduled Scan • 4,000,003 - Anti-Malware - Quick Scan • 4,000,010 - Anti-Spyware - Real-Time Scan • 4,000,011 - Anti-Spyware - Manual Scan

Signature IDs	Description
	<ul style="list-style-type: none"> • 4,000,012 - Anti-Spyware - Scheduled Scan • 4,000,013 - Anti-Spyware - Quick Scan • 4,000,020 - Suspicious Activity - Real-Time Scan • 4,000,030 - Unauthorized Change - Real-Time Scan
5,000,000-5,999,999	<p>Web Reputation events. Currently, only these signature IDs are used:</p> <ul style="list-style-type: none"> • 5,000,000 - Web Reputation - Blocked • 5,000,001 - Web Reputation - Detect Only
6,000,000-6,999,999	<p>Application Control events. Currently, only these signature IDs are used:</p> <ul style="list-style-type: none"> • 6,001,100 - Application Control - Detect Only, in block list • 6,001,200 - Application Control - Detect Only, not in allow list • 6,002,100 - Application Control - Blocked, in block list • 6,002,200 - Application Control - Blocked, not in allow list
7,000,000-7,999,999	<p>Device Control events. Currently, only these signature IDs are used:</p> <ul style="list-style-type: none"> • 7,000,000 - Device Control - access unknown device was blocked • 7,000,200 - Device Control - write unknown device was blocked • 7,001,000 - Device Control - access USB device was blocked • 7,001,200 - Device Control - write USB device was blocked • 7,002,000 - Device Control - access mobile device was blocked • 7,002,200 - Device Control - write mobile device was blocked

Note: Log entries don't always have all CEF extensions described in the event log format tables below. CEF extensions also may not be always in the same order. If you are using regular expressions (regex) to parse the entries, make sure your expressions do not depend on each key-value pair to exist, or to be in a specific order.

Note: Syslog messages are limited to 64 KB by the syslog protocol specification. If the message is longer, data may be truncated. The basic syslog format is limited to 1 KB.

LEEF 2.0 syslog message format

Base LEEF 2.0 format: LEEF:2.0|Vendor|Product|Version|EventID|(Delimiter Character, optional if the Delimiter Character is tab)|Extension

Sample LEEF 2.0 Log Entry (DSM System Event Log Sample): LEEF:2.0|Trend Micro|Deep Security Manager|<DSA version>|192|cat=System name=Alert Ended desc=Alert: CPU Warning Threshold Exceeded\nSubject: 10.201.114.164\nSeverity: Warning sev=3 src=10.201.114.164 usrName=System msg=Alert: CPUWarning Threshold Exceeded\nSubject: 10.201.114.164\nSeverity:Warning TrendMicroDsTenant=Primary

Events originating in the manager

System event log format

Base CEF Format: CEF:Version|Device Vendor|Device Product|Device Version|Signature ID|Name|Severity|Extension

Sample CEF Log Entry: CEF:0|Trend Micro|Deep Security Manager|<DSM version>|600|User Signed In|3|src=10.52.116.160 suser=admin target=admin msg=User signed in from 2001:db8::5

Base LEEF 2.0 format: LEEF:2.0|Vendor|Product|Version|EventID|(Delimiter Character, optional if the Delimiter Character is tab)|Extension

Sample LEEF 2.0 Log Entry: LEEF:2.0|Trend Micro|Deep Security Manager|<DSA version>|192|cat=System name=Alert Ended desc=Alert: CPU Warning Threshold Exceeded\nSubject: 10.201.114.164\nSeverity: Warning sev=3 src=10.201.114.164 usrName=System msg=Alert: CPU Warning Threshold Exceeded\nSubject: 10.201.114.164\nSeverity: Warning TrendMicroDsTenant=Primary

Note: LEEF format uses a reserved "sev" key to show severity and "name" for the Name value.

CEF Extension Field	LEEF Extension Field	Name	Description	Examples
src	src	Source IP Address	Deep Security Manager IP address.	src=10.52.116.23
suser	usrName	Source User	Deep Security Manager administrator's account.	suser=MasterAdmin

CEF Extension Field	LEEF Extension Field	Name	Description	Examples
target	target	Target Entity	The subject of the event. It can be the administrator account logged into Deep Security Manager, or a computer.	target=MasterAdmin target=server01
targetID	targetID	Target Entity ID	The identifier added in the manager.	targetID=1
targetType	targetType	Target Entity Type	The event target entity type.	targetType=Host
msg	msg	Details	Details of the system event. May contain a verbose description of the event.	msg=User password incorrect for username MasterAdmin on an attempt to sign in from 127.0.0.1 msg=A Scan for Recommendations on computer (localhost) has completed...
TrendMicroDsTags	TrendMicroDsTags	Event Tags	Deep Security event tags assigned to the event	TrendMicroDsTags=suspicious
TrendMicroDsTenant	TrendMicroDsTenant	Tenant Name	Deep Security tenant	TrendMicroDsTenant=Primary
TrendMicroDsTenantId	TrendMicroDsTenantId	Tenant ID	Deep Security tenant ID	TrendMicroDsTenantId=0
TrendMicroDsReasonId	TrendMicroDsReasonId	Event reason ID	Indicates the reason ID for event descriptions. Each event has its own reason ID definition.	TrendMicroDsReasonId=1
None	sev	Severity	The severity of the event. 1 is the least	sev=3

CEF Extension Field	LEEF Extension Field	Name	Description	Examples
			severe; 10 is the most severe.	
None	cat	Category	Event category	cat=System
None	name	Name	Event name	name=Alert Ended
None	desc	Description	Event description	desc:Alert: CPU Warning Threshold Exceeded

Events originating in the agent

Anti-Malware event format

Base CEF format: CEF:Version|Device Vendor|Device Product|Device Version|Signature ID|Name|Severity|Extension

Sample CEF Log Entry: CEF:0|Trend Micro|Deep Security Agent|<DSA version>|4000000|Eicar_test_file|6|cn1=1 cn1Label=Host ID dvchost=hostname cn2=205 cn2Label=Quarantine File Size cs6=ContainerImageName | ContainerName | ContainerID cs6Label=Container filePath=C:\\Users\\trend\\Desktop\\eicar.exe act=Delete result=Delete msg=Realtime TrendMicroDsMalwareTarget=N/A TrendMicroDsMalwareTargetType=N/TrendMicroDsFileMD5=44D88612FEA8A8F36DE82E1278ABB02F TrendMicroDsFileSHA1=3395856CE81F2B7382DEE72602F798B642F14140 TrendMicroDsFileSHA256=275A021BBFB6489E54D471899F7DB9D1663FC695EC2FE2A2C4538AABF651FD0F TrendMicroDsDetectionConfidence=95 TrendMicroDsRelevantDetectionNames=Ransom_CERBER.BZC;Ransom_CERBER.C;Ransom_CRYPNISCA.SM

Base LEEF 2.0 format: LEEF:2.0|Vendor|Product|Version|EventID|(Delimiter Character, optional if the Delimiter Character is tab)|Extension

Sample LEEF Log Entry: LEEF: 2.0|Trend Micro|Deep Security Agent|<DSA version>|4000030|cat=Anti-Malware name=HEU_AEGIS_CRYPT desc=HEU_AEGIS_CRYPT sev=6 cn1=241 cn1Label=Host ID dvc=10.0.0.1 TrendMicroDsTags=FS TrendMicroDsTenant=Primary TrendMicroDsTenantId=0 filePath=C:\\Windows\\System32\\virus.exe act=Terminate msg=Realtime TrendMicroDsMalwareTarget=Multiple TrendMicroDsMalwareTargetType=File System TrendMicroDsFileMD5=1947A1BC0982C5871FA3768CD025453E#011 TrendMicroDsFileSHA1=5AD084DDCD8F80FBF2EE3F0E4F812E812DEE60C1#011 TrendMicroDsFileSHA256=25F231556700749F8F0394CAABDED83C2882317669DA2C01299B45173482FA6E TrendMicroDsDetectionConfidence=95

TrendMicroDsRelevantDetectionNames=Ransom_CERBER.BZC;Ransom_CERBER.C;Ransom_CRYPNISCA.SM

CEF Extension Field	LEEF Extension Field	Name	Description	Examples
cn1	cn1	Host Identifier	The agent computer's internal unique identifier.	cn1=1
cn1Label	cn1Label	Host ID	The name label for the field cn1.	cn1Label=Host ID
cn2	cn2	File Size	The size of the quarantine file.	cn2=100
cn2Label	cn2Label	File Size	The name label for the field cn2.	cn2Label=Quarantine File Size
cs3	cs3	Infected Resource	The path of the spyware item. This field is only for spyware detection events.	cs3=C:\test\atse_samples\SPYW_Test_Virus.exe
cs3Label	cs3Label	Infected	The	cs3Label=Infected Resource

CEF Extension Field	LEEF Extension Field	Name	Description	Examples
		Resource	name label for the field cs3. This field is only for spyware detection events.	
cs4	cs4	Resource Type	Resource Type values: 10=Files and Directories 11=System Registry 12=Internet Cookies 13=Internet URL Shortcut 14=Pro	cs4=10

CEF Extension Field	LEEF Extension Field	Name	Description	Examples
			grams in Memory 15=Program Startup Areas 16=Browser Helper Object 17=Layered Service Provider 18=Hosts File 19=Windows Policy Settings 20=Browser 23=Windows Shell	

CEF Extension Field	LEEF Extension Field	Name	Description	Examples
			Setting 24=IE Downloaded Program Files 25=Add/Remove Programs 26=Services other=Other For example, if there's a spyware file named spy.exe that creates a registry run key	

CEF Extension Field	LEEF Extension Field	Name	Description	Examples
			to keep its persistence after system reboot, there will be two items in the spyware report: the item for spy.exe has cs4=10 (Files and Directories), and the item for the run key registry has cs4=11 (System Registry).	

CEF Extension Field	LEEF Extension Field	Name	Description	Examples
			This field is only for spyware detection events.	
cs4Label	cd4Label	Resource Type	The name label for the field cs4. This field is only for spyware detection events.	cs4Label=Resource Type
cs5	cs5	Risk Level	Risk level values: 0=Very Low 25=Low 50=Medium 75=High 100=V	cs5=25

CEF Extension Field	LEEF Extension Field	Name	Description	Examples
			ery High This field is only for spyware detection events.	
cs5Label	cs5Label	Risk Level	The name label for the field cs5. This field is only for spyware detection events.	cs5Label=Risk Level
cs6	cs6	Container	The image name of the Docker container, container name, and container ID where the malware was	cs6=ContainerImageName ContainerName ContainerID

CEF Extension Field	LEEF Extension Field	Name	Description	Examples
			detected.	
cs6Label	cs6Label	Container	The name label for the field cs6.	cs6Label=Container
cs7	cs7	Flow	Indicates whether the packets that triggered this event were travelling with (forward) or against (reverse) the direction of traffic being monitored by the intrusion prevention rule. Flow values: FWD=	cs7=FWD

CEF Extension Field	LEEF Extension Field	Name	Description	Examples
			Connection Flow REV= Reverse Flow	
cs7Label	cs7Label	Flow	The name label for the field cs7.	cs7Label=Flow
filePath	filePath	File Path	The location of the malware file.	filePath=C:\\Users\\Mei\\Desktop\\virus.exe
act	act	Action	The action performed by the Anti-Malware engine. Possible values are: Deny Access, Quarantine, Delete, Pass, Clean, Terminate,	act=Clean act=Pass

CEF Extension Field	LEEF Extension Field	Name	Description	Examples
			and Unspecified.	
result	result	Result	The result of the failed Anti-Malware action.	result=Passed result=Deleted result=Quarantined result=Cleaned result=Access Denied result=Terminated result=Log result=Failed result=Pass Failed result=Delete Failed result=Quarantine Failed result=Clean Failed result=Terminate Failed result=Log Failed result=Scan Failed result=Passed (Scan Failed) result=Quarantined (Scan Failed) result=Quarantine Failed (Scan Failed) result=Deny Access (Scan Failed)
msg	msg	Message	The type of scan. Possible values are: Realtime, Scheduled, and Manual.	msg=Realtime msg=Scheduled
dvc	dvc	Device address	The IPv4 address for cn1.	dvc=10.1.144.199

CEF Extension Field	LEEF Extension Field	Name	Description	Examples
			Does not appear if the source is an IPv6 address or hostname. (Uses dvchost instead.)	
dvchost	dvchost	Device hostname	The hostname or IPv6 address for cn1. Does not appear if the source is an IPv4 address. (Uses dvc	dvchost=www.example.com dvchost=fe80::f018:a3c6:20f9:afa6%5

CEF Extension Field	LEEF Extension Field	Name	Description	Examples
			field instead.)	
TrendMicroDsBehaviorRuleID	TrendMicroDsBehaviorRuleID	Behavior monitoring rule ID	The behavior monitoring rule ID for internal malware case tracking.	BehaviorRuleID=CS913
TrendMicroDsBehaviorType	TrendMicroDsBehaviorType	Behavior Monitoring type	The type of behavior monitoring event detected.	BehaviorType=Threat-Detection
TrendMicroDsTags	TrendMicroDsTags	Events tags	Deep Security event tags assigned to the event	TrendMicroDsTags=suspicious
TrendMicroDsTenant	TrendMicroDsTenant	Tenant name	Deep Security tenant	TrendMicroDsTenant=Primary
TrendMicroDsTenantId	TrendMicroDsTenantId	Tenant ID	Deep Security tenant ID	TrendMicroDsTenantId=0

CEF Extension Field	LEEF Extension Field	Name	Description	Examples
TrendMicroDsMalwareTarget	TrendMicroDsMalwareTarget	Target(s)	<p>The file, process, or registry key (if any) that the malware was trying to affect. If the malware was trying to affect more than one, this field will contain the value "Multiple."</p> <p>Only suspicious activity</p>	<p>TrendMicroDsMalwareTarget=N/A</p> <p>TrendMicroDsMalwareTarget=C:\\Windows\\System32\\cmd.exe</p> <p>TrendMicroDsMalwareTarget=HKCU\\Software\\Microsoft\\Windows\\CurrentVersion\\Internet Settings</p> <p>TrendMicroDsMalwareTarget=Multiple</p>

CEF Extension Field	LEEF Extension Field	Name	Description	Examples
			monitoring and unauthorized change monitoring have values for this field.	
TrendMicroDsMalwareTargetCount	TrendMicroDsMalwareTargetCount	Target count	The number of target files.	TrendMicroDsMalwareTargetCount=3
TrendMicroDsMalwareTargetType	TrendMicroDsMalwareTargetType	Target Type	The type of system resource that this malware was trying to affect, such as the file system, a process, or Window	TrendMicroDsMalwareTargetType=N/A TrendMicroDsMalwareTargetType=Exploit TrendMicroDsMalwareTargetType=File System TrendMicroDsMalwareTargetType=Process TrendMicroDsMalwareTargetType=Registry

CEF Extension Field	LEEF Extension Field	Name	Description	Examples
			Windows registry. Only suspicious activity monitoring and unauthorized change monitoring have values for this field.	
TrendMicroDsProcess	TrendMicroDsProcess	Process	Process Name	TrendMicroDsProcess= abc.exe
TrendMicroDsFileMD5	TrendMicroDsFileMD5	File MD5	The MD5 hash of the file	TrendMicroDsFileMD5=1947A1BC0982C5871FA3768CD025453E
TrendMicroDsFileSHA1	TrendMicroDsFileSHA1	File SHA1	The SHA1 hash of the file	TrendMicroDsFileSHA1=5AD084DDCD8F80FBF2EE3F0E4F812E812DEE60C1
TrendMicroDsFileSHA256	TrendMicroDsFileSHA256	File SHA256	The SHA256 hash of the file	TrendMicroDsFileSHA256=25F231556700749F8F0394CAABDED83C2882317669DA2C01299B45173482FA6E
TrendMicroDsDetectionConfidence	TrendMicroDsDetectionConfidence	Threat	Indicates how	TrendMicroDsDetectionConfidence=95

CEF Extension Field	LEEF Extension Field	Name	Description	Examples
nce	nce	Probability	closely (in %) the file matched the malware model	
TrendMicroDsRelevantDetectionNames	TrendMicroDsRelevantDetectionNames	Predictive Threat Type	Indicates the most likely type of threat contained in the file after Machine Learning compared the analysis to other known threats (separate by semicolon";")	TrendMicroDsRelevantDetectionNames=Ransom_CERBER.BZC;Ransom_CERBER.C;Ransom_CRYPNISCA.SM
None	sev	Severity	The severity of the event. 1 is the least severe; 10 is the most	sev=6

CEF Extension Field	LEEF Extension Field	Name	Description	Examples
			severe.	
None	cat	Category	Category	cat=Anti-Malware
None	name	Name	Event name	name=SPYWARE_KEYL_ACTIVE
None	desc	Description	Event description. Anti-Malware uses the event name as the description.	desc=SPYWARE_KEYL_ACTIVE
TrendMicroDsCommandLine	TrendMicroDsCommandLine	Command Line	The commands that the subject process executes	TrendMicroDsCommandLine=/tmp/orca-testkit-sample/testsys_m64 -u 1000 -g 1000 -U 1000 -G 1000 -e cve_2017_16995 1 -d 4000000
TrendMicroDsCve	TrendMicroDsCve	CVE	The CVE information, if the process behavior is identified in one of Common Vulnerabilities and	TrendMicroDsCve=CVE-2016-5195,CVE-2016-5195,CVE-2016-5195

CEF Extension Field	LEEF Extension Field	Name	Description	Examples
			Exposures.	
TrendMicroDsMitre	TrendMicroDsMitre	MITRE	The MITRE information, if the process behavior is identified in one of MITRE attack scenarios.	TrendMicroDsMitre=T1068,T1068,T1068
suser	suser	username	The user account name who triggered this event	suser=root

Application Control event format

Base CEF format: CEF:Version|Device Vendor|Device Product|Device Version|Signature ID|Name|Severity|Extension

Example CEF Log Entry: CEF: 0|Trend Micro|Deep Security Agent|10.2.229|6001200|AppControl detectOnly|6|cn1=202 cn1Label=Host ID dvc=192.168.33.128 TrendMicroDsTenant=Primary TrendMicroDsTenantId=0 fileHash=80D4AC182F97D2AB48EE4310AC51DA5974167C596D133D64A83107B9069745E0 suser=root suid=0 act=detectOnly filePath=/home/user1/Desktop/Directory1//heartbeatSync.sh fsize=20 aggregationType=0 repeatCount=1 cs1=notWhitelisted cs1Label=actionReason cs2=0CC9713BA896193A527213D9C94892D41797EB7C cs2Label=sha1 cs3=7EA8EF10BEB2E9876D4D7F7E5A46CF8D cs3Label=md5

Base LEEF 2.0 format: LEEF:2.0|Vendor|Product|Version|EventID|(Delimiter Character, optional if the Delimiter Character is tab)|Extension

Example LEEF Log Entry: LEEF:2.0|Trend Micro|Deep Security

```
Agent|10.0.2883|60|cat=AppControl name=blocked desc=blocked sev=6 cn1=2
cn1Label=Host ID dvc=10.203.156.39 TrendMicroDsTenant=Primary TrendMicroDsTenantId=0
fileHash=E3B0C44298FC1C149AFBF4C8996FB92427AE41E4649B934CA495991B7852B85
5 suser=root suid=0 act=blocked filePath=/bin/my.jar fsize=123857 aggregationType=0
repeatCount=1 cs1=notWhitelisted cs1Label=actionReason
```

CEF Extension Field	LEEF Extension Field	Name	Description	Examples
cn1	cn1	Host Identifier	The agent computer's internal unique identifier.	cn1=2
cn1Label	cn1Label	Host ID	The name label for the field cn1.	cn1Label=Host ID
cs1	cs1	Reason	The reason why application control performed the specified action, such as "notWhitelisted" (the software did not have a matching rule, and application control	cs1=notWhitelisted

CEF Extension Field	LEEF Extension Field	Name	Description	Examples
			was configured to block unrecognized software).	
cs1Label	cs1Label		The name label for the field cs1.	cs1Label=actionReason
cs2	cs2		If it was calculated, the SHA-1 hash of the file.	cs2=156F4CB711FDBD668943711F853FB6DA89581AAD
cs2Label	cs2Label		The name label for the field cs2.	cs2Label=sha1
cs3	cs3		If it was calculated, the MD5 hash of the file.	cs3=4E8701AC951BC4537F8420FDAC7EFBB5
cs3Label	cs3Label		The name label for the field cs3.	cs3Label=md5
act	act	Action	The action performed by the Application Control engine. Possible values	act=blocked

CEF Extension Field	LEEF Extension Field	Name	Description	Examples
			are: Blocked, Allowed.	
dvc	dvc	Device address	The IPv4 address for cn1. Does not appear if the source is an IPv6 address or hostname. (Uses dvchost instead.)	dvc=10.1.1.10
dvchost	dvchost	Device hostname	The hostname or IPv6 address for cn1. Does not appear if the source is an IPv4 address. (Uses dvc field instead.)	dvchost=www.example.com dvchost=2001:db8::5
suid	suid	User ID	The account ID number of the user	suid=0

CEF Extension Field	LEEF Extension Field	Name	Description	Examples
			name.	
suser	suser	User Name	The name of the user account that installed the software on the protected computer.	suser=root
TrendMicroDsTenant	TrendMicroDsTenant	Tenant name	Deep Security tenant name.	TrendMicroDsTenant=Primary
TrendMicroDsTenantId	TrendMicroDsTenantId	Tenant ID	Deep Security tenant ID number.	TrendMicroDsTenantId=0
fileHash	fileHash	File hash	The SHA 256 hash that identifies the software file.	fileHash=E3B0C44298FC1C149AFBF4C8996FB92427AE41E4649B934CA495991B7852B855
filePath	filePath	File Path	The location of the malware file.	filePath=/bin/my.jar
filesize	filesize	File Size	The file size in bytes.	filesize=16
aggregationType	aggregationType	Aggregation Type	An integer that indicates how the event is	aggregationType=2

CEF Extension Field	LEEF Extension Field	Name	Description	Examples
			aggregated: <ul style="list-style-type: none"> • 0: The event is not aggregated • 1: The event is aggregated based on filename, path, and 	

CEF Extension Field	LEEF Extension Field	Name	Description	Examples
			<p> d e v e n t t y p e. • 2: T h e e v e n t i s a g g r e g a t e d b a s e d o n e v e n t t y p e. F o r i n f o r m a t i o n, a b o u t e v e n t a g g r e g a t i o n, s e e "View A p p l i c a t i o n C o n t r o l </p>	

CEF Extension Field	LEEF Extension Field	Name	Description	Examples
			event logs" on page 1084.	
repeatCount	repeatCount	Repeat Count	The number of occurrences of the event. Non-aggregated events have a value of 1. Aggregated events have a value of 2 or more.	repeatCount=4
None	sev	Severity	The severity of the event. 1 is the least severe; 10 is the most severe.	sev=6
None	cat	Category	Category	cat=AppControl
None	name	Name	Event name	name=blocked
None	desc	Description	Event description. Application	desc=blocked

CEF Extension Field	LEEF Extension Field	Name	Description	Examples
			Control uses the action as the description.	

Firewall event log format

Base CEF format: CEF:Version|Device Vendor|Device Product|Device Version|Signature ID|Name|Severity|Extension

Sample CEF Log Entry: CEF:0|Trend Micro|Deep Security Agent|<DSA version>|20|Log for TCP Port 80|0|cn1=1 cn1Label=Host ID dvc=hostname act=Log dmac=00:50:56:F5:7F:47 smac=00:0C:29:EB:35:DE TrendMicroDsFrameType=IP src=192.168.126.150 dst=72.14.204.147 out=1019 cs3=DF MF cs3Label=Fragmentation Bits proto=TCP spt=49617 dpt=80 cs2=0x00 ACK PSH cs2Label=TCP Flags cnt=1 TrendMicroDsPacketData=AFB...

Sample LEEF Log Entry: LEEF:2.0|Trend Micro|Deep Security Agent|<DSA version>|21|cat=Firewall name=Remote Domain Enforcement (Split Tunnel) desc=Remote Domain Enforcement (Split Tunnel) sev=5 cn1=37 cn1Label=Host ID dvchost=www.example.com TrendMicroDsTenant=Primary TrendMicroDsTenantId=0 act=Deny dstMAC=67:BF:1B:2F:13:EE srcMAC=78:FD:E7:07:9F:2C TrendMicroDsFrameType=IP src=10.0.110.221 dst=105.152.185.81 out=177 cs3= cs3Label=Fragmentation Bits proto=UDP srcPort=23 dstPort=445 cnt=1 TrendMicroDsPacketData=AFB...

CEF Extension Field	LEEF Extension Field	Name	Description	Examples
act	act	Action		act=Log act=Deny
cn1	cn1	Host Identifier	The agent computer's internal unique identifier.	cn1=113
cn1Label	cn1Label	Host ID	The name label for the field cn1.	cn1Label=Host ID

CEF Extension Field	LEEF Extension Field	Name	Description	Examples
cnt	cnt	Repeat Count	The number of times this event was sequentially repeated.	cnt=8
cs2	cs2	TCP Flags		cs2=0x10 ACK cs2=0x14 ACK RST
cs2Label	cs2Label	TCP Flags	The name label for the field cs2.	cs2Label=TCP Flags
cs3	cs3	Packet Fragmentation Information		cs3=DF cs3=MF cs3=DF MF
cs3Label	cs3Label	Fragmentation Bits	The name label for the field cs3.	cs3Label=Fragmentation Bits
cs4	cs4	ICMP Type and Code	(For the ICMP protocol only) The ICMP type and code, delimited by a space.	cs4=11 0 cs4=8 0
cs4Label	cs4Label	ICMP	The name label for the field cs4.	cs4Label=ICMP Type and Code
dmac	dstMAC	Destination MAC Address	MAC address of the destination computer's network	dmac= 00:0C:29:2F:09:B3

CEF Extension Field	LEEF Extension Field	Name	Description	Examples
			interface.	
dpt	dstPort	Destination Port	(For TCP and UDP protocol only) Port number of the destination computer's connection or session.	dpt=80 dpt=135
dst	dst	Destination IP Address	IP address of the destination computer.	dst=192.168.1.102 dst=10.30.128.2
in	in	Inbound Bytes Read	(For inbound connections only) Number of inbound bytes read.	in=137 in=21
out	out	Outbound Bytes Read	(For outbound connections only) Number of outbound bytes read.	out=216 out=13
proto	proto	Transport protocol	Name of the transport protocol used.	proto=tcp proto=udp proto=icmp
smac	srcMAC	Source MAC Address	MAC address of the	smac= 00:0E:04:2C:02:B3

CEF Extension Field	LEEF Extension Field	Name	Description	Examples
			source computer's network interface.	
spt	srcPort	Source Port	(For TCP and UDP protocol only) Port number of the source computer's connection or session.	spt=1032 spt=443
src	src	Source IP Address	The packet's source IP address at this event.	src=192.168.1.105 src=10.10.251.231
TrendMicroDsFrameType	TrendMicroDsFrameType	Ethernet frame type	Connection ethernet frame type.	TrendMicroDsFrameType=IP TrendMicroDsFrameType=ARP TrendMicroDsFrameType=RevARP TrendMicroDsFrameType=NetBEUI
TrendMicroDsPacketData	TrendMicroDsPacketData	Packet data	The packet data, represented in Base64.	TrendMicroDsPacketData=AFB...
dvc	dvc	Device address	The IPv4 address for cn1. Does not appear if	dvc=10.1.144.199

CEF Extension Field	LEEF Extension Field	Name	Description	Examples
			the source is an IPv6 address or hostname. (Uses dvchost instead.)	
dvchost	dvchost	Device hostname	The hostname or IPv6 address for cn1. Does not appear if the source is an IPv4 address. (Uses dvc field instead.)	dvchost=exch01.example.com dvchost=2001:db8::5
TrendMicroDsTags	TrendMicroDsTags	Event Tags	Deep Security event tags assigned to the event	TrendMicroDsTags=suspicious
TrendMicroDsTenant	TrendMicroDsTenant	Tenant Name	Deep Security tenant	TrendMicroDsTenant=Primary
TrendMicroDsTenantId	TrendMicroDsTenantId	Tenant ID	Deep Security tenant ID	TrendMicroDsTenantId=0
None	sev	Severity	The severity of the	sev=5

CEF Extension Field	LEEF Extension Field	Name	Description	Examples
			event. 1 is the least severe; 10 is the most severe.	
None	cat	Category	Category	cat=Firewall
None	name	Name	Event name	name=Remote Domain Enforcement (Split Tunnel)
None	desc	Description	Event description. Firewall events use the event name as the description.	desc=Remote Domain Enforcement (Split Tunnel)

Integrity Monitoring log event format

Base CEF format: CEF:Version|Device Vendor|Device Product|Device Version|Signature ID|Name|Severity|Extension

Sample CEF Log Entry: CEF:0|Trend Micro|Deep Security Agent|<DSA version>|30|New Integrity Monitoring Rule|6|cn1=1 cn1Label=Host ID dvchost=hostname act=updated filePath=c:\\windows\\message.dll suser=admin sproc=C:\\Windows\\System32\\notepad.exe msg=lastModified,sha1,size

Base LEEF 2.0 format: LEEF:2.0|Vendor|Product|Version|EventID|(Delimiter Character, optional if the Delimiter Character is tab)|Extension

Sample LEEF Log Entry: LEEF:2.0|Trend Micro|Deep Security Agent|<DSA version>|2002779|cat=Integrity Monitor name=Microsoft Windows - System file modified desc=Microsoft Windows - System file modified sev=8 cn1=37 cn1Label=Host ID dvchost=www.example.com TrendMicroDsTenant=Primary TrendMicroDsTenantId=0 act=updated suser=admin sproc=C:\\Windows\\System32\\notepad.exe

CEF Extension Field	LEEF Extension Field	Name	Description	Examples
act	act	Action	The action detected by the integrity rule. Can contain: created, updated, deleted or renamed.	act=created act=deleted
cn1	cn1	Host Identifier	The agent computer's internal unique identifier.	cn1=113
cn1Label	cn1Label	Host ID	The name label for the field cn1.	cn1Label=Host ID
filePath	filePath	Target Entity	The integrity rule target entity. May contain a file or directory path, registry key, etc.	filePath=C:\WINDOWS\system32\drivers\etc\hosts
suser	suser	Source User	Account of the user who changed the file being monitored.	suser=WIN-038M7CQDHIN\Administrator
sproc	sproc	Source Process	The name of the	sproc=C:\\Windows\\System32\\notepad.exe

CEF Extension Field	LEEF Extension Field	Name	Description	Examples
			event's source process.	
msg	msg	Attribute changes	(For "renamed" action only) A list of changed attribute names. If "Relay via Manager" is selected, all event action types include a full description.	msg=lastModified,sha1,size
oldfilePath	oldfilePath	Old target entity	(For "renamed" action only) The previous integrity rule target entity to capture the rename action from the previous target entity to the new, which is recorded in the filePath field.	oldFilePath=C:\WINDOWS\system32\logfiles\ds_agent.log

CEF Extension Field	LEEF Extension Field	Name	Description	Examples
dvc	dvc	Device address	The IPv4 address for cn1. Does not appear if the source is an IPv6 address or hostname. (Uses dvchost instead.)	dvc=10.1.144.199
dvchost	dvchost	Device host name	The hostname or IPv6 address for cn1. Does not appear if the source is an IPv4 address. (Uses dvc field instead.)	dvchost=www.example.com dvchost=2001:db8::5
TrendMicroDsTags	TrendMicroDsTags	Events tags	Deep Security event tags assigned to the event	TrendMicroDsTags=suspicious
TrendMicroDsTenant	TrendMicroDsTenant	Tenant name	Deep Security	TrendMicroDsTenant=Primary

CEF Extension Field	LEEF Extension Field	Name	Description	Examples
			tenant	
TrendMicroDsTenantId	TrendMicroDsTenantId	Tenant ID	Deep Security tenant ID	TrendMicroDsTenantId=0
None	sev	Severity	The severity of the event. 1 is the least severe; 10 is the most severe.	sev=8
None	cat	Category	Category	cat=Integrity Monitor
None	name	Name	Event name	name=Microsoft Windows - System file modified
None	desc	Description	Event description. Integrity Monitoring uses the event name as the description.	desc=Microsoft Windows - System file modified

Intrusion Prevention event log format

Base CEF format: CEF:Version|Device Vendor|Device Product|Device Version|Signature ID|Name|Severity|Extension

Sample CEF Log Entry: CEF:0|Trend Micro|Deep Security Agent|<DSA version>|1001111|Test Intrusion Prevention Rule|3|cn1=1 cn1Label=Host ID dvchost=hostname dmac=00:50:56:F5:7F:47 smac=00:0C:29:EB:35:DE TrendMicroDsFrameType=IP src=192.168.126.150 dst=72.14.204.105 out=1093 cs3=DF MF cs3Label=Fragmentation Bits proto=TCP spt=49786 dpt=80 cs2=0x00 ACK PSH cs2Label=TCP Flags cnt=1 act=IDS:Reset cn3=10 cn3Label=Intrusion Prevention Packet Position cs5=10 cs5Label=Intrusion Prevention Stream Position cs6=8 cs6Label=Intrusion Prevention Flags TrendMicroDsPacketData=R0VUIC9zP3...

Base LEEF 2.0 format: LEEF:2.0|Vendor|Product|Version|EventID|(Delimiter Character, optional if the Delimiter Character is tab)|Extension

Sample LEEF Log Entry: LEEF:2.0|Trend Micro|Deep Security Agent|<DSA version>|1000940|cat=Intrusion Prevention name=Sun Java RunTime Environment Multiple Buffer Overflow Vulnerabilities desc=Sun Java RunTime Environment Multiple Buffer Overflow Vulnerabilities sev=10 cn1=6 cn1Label=Host ID dvchost=exch01 TrendMicroDsTenant=Primary TrendMicroDsTenantId=0 dstMAC=55:C0:A8:55:FF:41 srcMAC=CA:36:42:B1:78:3D TrendMicroDsFrameType=IP src=10.0.251.84 dst=56.19.41.128 out=166 cs3=cs3Label=Fragmentation Bits proto=ICMP srcPort=0 dstPort=0 cnt=1 act=IDS:Reset cn3=0 cn3Label=DPI Packet Position cs5=0 cs5Label=DPI Stream Position cs6=0 cs6Label=DPI Flags TrendMicroDsPacketData=R0VUIC9zP3...

CEF Extension Field	LEEF Extension Field	Name	Description	Examples
act	act	Action	(IPS rules written before Deep Security version 7.5 SP1 could additionally perform Insert, Replace, and Delete actions. These actions are no longer performed. If an older IPS Rule is triggered which still attempts to perform those actions, the event	act=Block

CEF Extension Field	LEEF Extension Field	Name	Description	Examples
			will indicate that the rule was applied in detect-only mode.)	
cn1	cn1	Host Identifier	The agent computer's internal unique identifier.	cn1=113
cn1Label	cn1Label	Host ID	The name label for the field cn1.	cn1Label=Host ID
cn3	cn3	Intrusion Prevention Packet Position	Position within packet of data that triggered the event.	cn3=37
cn3Label	cn3Label	Intrusion Prevention Packet Position	The name label for the field cn3.	cn3Label=Intrusion Prevention Packet Position
cnt	cnt	Repeat Count	The number of times this event was sequentially repeated.	cnt=8
cs1	cs1	Intrusion Prevention Filter Note	(Optional) A note field which can contain a short	cs1=Drop_data

CEF Extension Field	LEEF Extension Field	Name	Description	Examples
			binary or text note associated with the payload file. If the value of the note field is all printable ASCII characters, it will be logged as text with spaces converted to underscores. If it contains binary data, it will be logged using Base-64 encoding.	
cs1Label	cs1Label	Intrusion Prevention Note	The name label for the field cs1.	cs1Label=Intrusion Prevention Note
cs2	cs2	TCP Flags	(For the TCP protocol only) The raw TCP flag byte followed by the URG, ACK, PSH, RST,	cs2=0x10 ACK cs2=0x14 ACK RST

CEF Extension Field	LEEF Extension Field	Name	Description	Examples
			SYN and FIN fields may be present if the TCP header was set.	
cs2Label	cs2Label	TCP Flags	The name label for the field cs2.	cs2Label=TCP Flags
cs3	cs3	Packet Fragmentation Information		cs3=DF cs3=MF cs3=DF MF
cs3Label	cs3Label	Fragmentation Bits	The name label for the field cs3.	cs3Label=Fragmentation Bits
cs4	cs4	ICMP Type and Code	(For the ICMP protocol only) The ICMP type and code stored in their respective order delimited by a space.	cs4=11 0 cs4=8 0
cs4Label	cs4Label	ICMP	The name label for the field cs4.	cs4Label=ICMP Type and Code
cs5	cs5	Intrusion Prevention Stream Position	Position within stream of data that triggered the event.	cs5=128 cs5=20

CEF Extension Field	LEEF Extension Field	Name	Description	Examples
cs5Label	cs5Label	Intrusion Prevention Stream Position	The name label for the field cs5.	cs5Label=Intrusion Prevention Stream Position
cs6	cs6	Intrusion Prevention Filter Flags	<p>A combined value that includes the sum of the flag values:</p> <ul style="list-style-type: none"> 1 - Data truncated - Data could not be logged. 2 - Log Overflow - Log overflowed after this log. 4 - Suppressed - Logs threshold suppressed after this log. 8 - Have Data - Contains packet data 16 - Reference Data - References previously logged data. 	The following example would be a summed combination of 1 (Data truncated) and 8 (Have Data): cs6=9
cs6Label	cs6Label	Intrusion Prevention	The name	cs6=Intrusion Prevention Filter Flags

CEF Extension Field	LEEF Extension Field	Name	Description	Examples
		Flags	label for the field cs6.	
dmac	dstMAC	Destination MAC Address	Destination computer network interface MAC address.	dmac= 00:0C:29:2F:09:B3
dpt	dstPort	Destination Port	(For TCP and UDP protocol only) Destination computer connection port.	dpt=80 dpt=135
dst	dst	Destination IP Address	Destination computer IP Address.	dst=192.168.1.102 dst=10.30.128.2
xff	xff	X-Forwarded-For	The IP addresses of the last hub in the X-Forwarded-For header. This is typically originating IP address, beyond the proxy that may exist. See also the src field. To include xff in	xff=192.168.137.1

CEF Extension Field	LEEF Extension Field	Name	Description	Examples
			events, enable the "1006540 - Enable X-Forwarded-For HTTP Header Logging" Intrusion Prevention rule .	
in	in	Inbound Bytes Read	(For inbound connections only) Number of inbound bytes read.	in=137 in=21
out	out	Outbound Bytes Read	(For outbound connections only) Number of outbound bytes read.	out=216 out=13
proto	proto	Transport protocol	Name of the connection transport protocol used.	proto=tcp proto=udp proto=icmp
smac	srcMAC	Source MAC Address	Source computer network interface MAC address.	smac= 00:0E:04:2C:02:B3
spt	srcPort	Source	(For TCP	spt=1032

CEF Extension Field	LEEF Extension Field	Name	Description	Examples
		Port	and UDP protocol only) Source computer connection port.	spt=443
src	src	Source IP Address	Source computer IP Address. This is the IP of the last proxy server, if it exists, or the client IP. See also the xff field.	src=192.168.1.105 src=10.10.251.231
TrendMicroDsFrameType	TrendMicroDsFrameType	Ethernet frame type	Connection ethernet frame type.	TrendMicroDsFrameType=IP TrendMicroDsFrameType=ARP TrendMicroDsFrameType=RevARP TrendMicroDsFrameType=NetB EUI
TrendMicroDsPacketData	TrendMicroDsPacketData	Packet data	The packet data, represented in Base64.	TrendMicroDsPacketData=R0V UIC9zP3...
dvc	dvc	Device address	The IPv4 address for cn1. Does not appear if the	dvc=10.1.144.199

CEF Extension Field	LEEF Extension Field	Name	Description	Examples
			source is an IPv6 address or hostname. (Uses dvchost instead.)	
dvchost	dvchost	Device host name	The hostname or IPv6 address for cn1. Does not appear if the source is an IPv4 address. (Uses dvc field instead.)	dvchost=www.example.com dvchost=2001:db8::5
TrendMicroDsTags	TrendMicroDsTags	Event tags	Deep Security event tags assigned to the event	TrendMicroDsTags=Suspicious
TrendMicroDsTenant	TrendMicroDsTenant	Tenant name	Deep Security tenant name	TrendMicroDsTenant=Primary
TrendMicroDsTenantId	TrendMicroDsTenantId	Tenant ID	Deep Security tenant ID	TrendMicroDsTenantId=0
None	sev	Severity	The severity of the	sev=10

CEF Extension Field	LEEF Extension Field	Name	Description	Examples
			event. 1 is the least severe; 10 is the most severe.	
None	cat	Category	Category	cat=Intrusion Prevention
None	name	Name	Event name	name=Sun Java RunTime Environment Multiple Buffer Overflow Vulnerabilities
None	desc	Description	Event description. Intrusion Prevention events use the event name as the description.	desc=Sun Java RunTime Environment Multiple Buffer Overflow Vulnerabilities

Log Inspection event format

Base CEF format: CEF:Version|Device Vendor|Device Product|Device Version|Signature ID|Name|Severity|Extension

Sample CEF Log Entry: CEF:0|Trend Micro|Deep Security Agent|<DSA version>|3002795|Microsoft Windows Events|8|cn1=1 cn1Label=Host ID dvchost=hostname cs1Label=LI Description cs1=Multiple Windows Logon Failures fname=Security src=127.0.0.1 duser=(no user) shost=WIN-RM6HM42G65V msg=WinEvtLog Security: AUDIT_FAILURE (4625): Microsoft-Windows-Security-Auditing: (no user): no domain: WIN-RM6HM42G65V: An account failed to log on. Subject: ..

Base LEEF 2.0 format: LEEF:2.0|Vendor|Product|Version|EventID|(Delimiter Character, optional if the Delimiter Character is tab)|Extension

Sample LEEF Log Entry: LEEF:2.0|Trend Micro|Deep Security Agent|<DSA version>|3003486|cat=Log Inspection name=Mail Server - MDaemon desc=Server Shutdown. sev=3 cn1=37 cn1Label=Host ID dvchost=exch01.example.com TrendMicroDsTenant=Primary TrendMicroDsTenantId=0 cs1=Server Shutdown. cs1Label=LI Description fname= shost= msg=

CEF Extension Field	LEEF Extension Field	Name	Description	Examples
cn1	cn1	Host Identifier	The agent computer's internal unique identifier.	cn1=113
cn1Label	cn1Label	Host ID	The name label for the field cn1.	cn1Label=Host ID
cs1	cs1	Specific Sub-Rule	The Log Inspection sub-rule which triggered this event.	cs1=Multiple Windows audit failure events
cs1Label	cs1Label	LI Description	The name label for the field cs1.	cs1Label=LI Description
duser	duser	User Information	(If parseable username exists) The name of the target user initiated the log entry.	duser=(no user) duser=NETWORK SERVICE
fname	fname	Target entity	The Log Inspection rule target entity. May contain a file or directory path, registry key, etc.	fname=Application fname=C:\Program Files\CMS\logs\server0.log
msg	msg	Details	Details of the Log Inspection event. May contain a verbose description	msg=WinEvtLog: Application: AUDIT_FAILURE(20187): pgEvent: (no user): no domain: SERVER01: Remote login failure for user 'xyz'

CEF Extension Field	LEEF Extension Field	Name	Description	Examples
			of the detected log event.	
shost	shost	Source Hostname	Source computer hostname.	shost=webserver01.corp.com
src	src	Source IP Address	Source computer IP address.	src=192.168.1.105 src=10.10.251.231
dvc	dvc	Device address	The IPv4 address for cn1. Does not appear if the source is an IPv6 address or hostname. (Uses dvchost instead.)	dvc=10.1.144.199
dvchost	dvchost	Device host name	The hostname or IPv6 address for cn1. Does not appear if the source is an IPv4 address. (Uses dvc field instead.)	dvchost=www.example.com dvchost=2001:db8::5
TrendMicroDsTags	TrendMicroDsTags	Events tags	Deep Security event tags assigned	TrendMicroDsTags=suspicious

CEF Extension Field	LEEF Extension Field	Name	Description	Examples
			to the event	
TrendMicroDsTenant	TrendMicroDsTenant	Tenant name	Deep Security tenant	TrendMicroDsTenant=Primary
TrendMicroDsTenantId	TrendMicroDsTenantId	Tenant ID	Deep Security tenant ID	TrendMicroDsTenantId=0
None	sev	Severity	The severity of the event. 1 is the least severe; 10 is the most severe.	sev=3
None	cat	Category	Category	cat=Log Inspection
None	name	Name	Event name	name=Mail Server - MDaemon
None	desc	Description	Event description.	desc=Server Shutdown

Web Reputation event format

Base CEF format: CEF:Version|Device Vendor|Device Product|Device Version|Signature ID|Name|Severity|Extension

Sample CEF Log Entry: CEF:0|Trend Micro|Deep Security Agent|<DSA version>|5000000|WebReputation|5|cn1=1 cn1Label=Host ID dvchost=hostname request=example.com msg=Blocked By Admin

Base LEEF 2.0 format: LEEF:2.0|Vendor|Product|Version|EventID|(Delimiter Character, optional if the Delimiter Character is tab)|Extension

Sample LEEF Log Entry: LEEF:2.0|Trend Micro|Deep Security Agent|<DSA version>|5000000|cat=Web Reputation name=WebReputation desc=WebReputation sev=6 cn1=3 cn1Label=Host ID dvchost=exch01.example.com TrendMicroDsTenant=Primary TrendMicroDsTenantId=0 request=http://yw.olx5x9ny.org.it/HvuauRH/eighgSS.htm msg=Suspicious

CEF Extension Field	LEEF Extension Field	Name	Description	Examples
cn1	cn1	Host Identifier	The agent computer's internal unique identifier.	cn1=1
cn1Label	cn1Label	Host ID	The name label for the field cn1.	cn1Label=Host ID
request	request	Request	The URL of the request.	request=http://www.example.com/index.php
msg	msg	Message	The type of action. Possible values are: Realtime, Scheduled, and Manual.	msg=Realtime msg=Scheduled
dvc	dvc	Device address	The IPv4 address for cn1. Does not appear if the source is an IPv6 address or hostname. (Uses dvchost instead.)	dvc=10.1.144.199
dvchost	dvchost	Device host name	The hostname or IPv6 address for cn1.	dvchost=www.example.com dvchost=2001:db8::5

CEF Extension Field	LEEF Extension Field	Name	Description	Examples
			Does not appear if the source is an IPv4 address. (Uses dvc field instead.)	
TrendMicroDsTags	TrendMicroDsTags	Events tags	Deep Security event tags assigned to the event	TrendMicroDsTags=suspicious
TrendMicroDsTenant	TrendMicroDsTenant	Tenant name	Deep Security tenant	TrendMicroDsTenant=Primary
TrendMicroDsTenantId	TrendMicroDsTenantId	Tenant ID	Deep Security tenant ID	TrendMicroDsTenantId=0
None	sev	Severity	The severity of the event. 1 is the least severe; 10 is the most severe.	sev=6
None	cat	Category	Category	cat=Web Reputation
None	name	Name	Event name	name=WebReputation
None	desc	Description	Event description. Web Reputation uses the event name as the description.	desc=WebReputation

Device Control event format

Base CEF format: CEF:Version|Device Vendor|Device Product|Device Version|Signature ID|Name|Severity|Extension

Sample CEF Log Entry: CEF:0|Trend Micro|Deep Security Agent|50.0.1063|7000000|Device Control DeviceControl|6|cn1=1 cn1Label=Host ID dvchost=test-hostname TrendMicroDsTenant=tenantName TrendMicroDsTenantId=1 device=deviceName processName=processName1 fileName=/tmp/some_path2 vendor=vendorName serial=aaaa-bbbb-cccc model=modelName computerName=computerName domainName=computerDomain deviceType=0 permission=0

Base LEEF 2.0 format: LEEF:2.0|Vendor|Product|Version|EventID|(Delimiter Character, optional if the Delimiter Character is tab)|Extension

Sample LEEF Log Entry: LEEF:2.0|Trend Micro|Deep Security Agent|50.0.1063|7000000|cat=Device Control name=DeviceControl desc=DeviceControl sev=6 cn1=1 cn1Label=Host ID dvchost=test-hostname TrendMicroDsTenant=tenantName TrendMicroDsTenantId=1 device=deviceName processName=processName1 fileName=/tmp/some_path2 vendor=vendorName serial=aaaa-bbbb-cccc model=modelName computerName=computerName domainName=computerDomain deviceType=0 permission=0

CEF Extension Field	LEEF Extension Field	Name	Description	Examples
cn1	cn1	Host Identifier	The agent computer's internal unique identifier.	cn1=1
cn1Label	cn1Label	Host ID	The name label for the field cn1.	cn1Label=Host ID
dvchost	dvchost	Device host name	The hostname or IPv6 address for cn1. Does not appear if the source	dvchost=www.example.com dvchost=2001:db8::5

CEF Extension Field	LEEF Extension Field	Name	Description	Examples
			is an IPv4 address. (Uses dvc field instead.)	
TrendMicroDsTenant	TrendMicroDsTenant	Tenant name	Deep Security tenant	TrendMicroDsTenant=Primary
TrendMicroDsTenantId	TrendMicroDsTenantId	Tenant ID	Deep Security tenant ID	TrendMicroDsTenantId=0
device	device	Device Name	The device that was accessed.	device=Sandisk_USB
processName	processName	Process Name	The process name.	processName=someProcess.exe
fileName	fileName	File Name	The file name that was accessed.	fileName=E:\somepath\a.exe
vendor	vendor	Vendor Name	The vendor name of the device.	vendor=sandisk
serial	serial	Serial Number	The serial number of the device.	serial=aaa-bbb-ccc
model	model	Model	The product name of the device.	model=A270_USB
computerName	computerName	Computer Name	The computer name.	computerName=Jonh_Computer
domainName	domainName	Domain Name	The domain name.	domainName=CompanyDomain
deviceType	deviceType	Device Type	The device type of the device USB_STORAGE_	deviceType=1

CEF Extension Field	LEEF Extension Field	Name	Description	Examples
			DEVICE(1) MOBILE_DEVICE(2)	
permission	permission	Permission	The block reason of the access BLOCK(0) READ_ONLY(2)	permission=0

Configure Red Hat Enterprise Linux to receive event logs

Set up a Syslog on Red Hat Enterprise Linux 8

The following steps describe how to configure rsyslog on Red Hat Enterprise Linux 8 to receive logs from Deep Security.

1. Log in as root
2. Execute:

```
vi /etc/rsyslog.conf
```
3. Uncomment the following lines near the top of the `rsyslog.conf` to change them from:

```
#module(load="imudp")
#input(type="imudp" port="514")
|
#module(load="imtcp")
#input(type="imtcp" port="514")
|
to

module(load="imudp")
input(type="imudp" port="514")
|
module(load="imtcp")
input(type="imtcp" port="514")
|
```

4. Add the following two lines of text to the end of the `rsyslog.conf`:
 - `#Save Deep Security Manager logs to DSM.log`
 - `Local4.* /var/log/DSM.log`

Note: You may need to replace `Local4` with another value, depending on your Manager settings.

5. Save the file and exit
6. Create the `/var/log/DSM.log` file by typing `touch /var/log/DSM.log`
7. Set the permissions on the DSM log so that syslog can write to it
8. Save the file and exit
9. Restart syslog: `systemctl restart rsyslog`

When Syslog is functioning you will see logs populated in: `/var/log/DSM.log`

Set up a Syslog on Red Hat Enterprise Linux 6 or 7

The following steps describe how to configure rsyslog on Red Hat Enterprise Linux 6 or 7 to receive logs from Deep Security.

1. Log in as root
2. Execute:

```
vi /etc/rsyslog.conf
```
3. Uncomment the following lines near the top of the `rsyslog.conf` to change them from:

```
#ModLoad imudp
#UDPServerRun 514
#ModLoad imtcp
#InputTCPServerRun 514
```

to

```
ModLoad imudp
UDPServerRun 514
ModLoad imtcp
InputTCPServerRun 514
```

4. Add the following two lines of text to the end of the `rsyslog.conf`:
 - `#Save Deep Security Manager logs to DSM.log`
 - `Local4.* /var/log/DSM.log`

Note: You may need to replace `Local4` with another value, depending on your Manager settings.

5. Save the file and exit
6. Create the `/var/log/DSM.log` file by typing `touch /var/log/DSM.log`
7. Set the permissions on the DSM log so that syslog can write to it
8. Save the file and exit
9. Restart syslog: `service rsyslog restart`

When Syslog is functioning you will see logs populated in: `/var/log/DSM.log`

Set up a Syslog on Red Hat Enterprise Linux 5

The following steps describe how to configure Syslog on Red Hat Enterprise Linux to receive logs from Deep Security.

1. Log in as root
2. Execute:

```
vi /etc/syslog.conf
```
3. Add the following two lines of text to the end of the `syslog.conf` :
 - `#Save Deep Security Manager logs to DSM.log`
 - `Local4.* /var/log/DSM.log`

Note: You may need to replace `Local4` with another value, depending on your Manager settings.

4. Save the file and exit
5. Create the `/var/log/DSM.log` file by typing `touch /var/log/DSM.log`
6. Set the permissions on the DSM log so that syslog can write to it
7. Execute:

```
vi /etc/sysconfig/syslog
```
8. Modify the line "`SYSLOGD_OPTIONS`" and add a "`-r`" to the options
9. Save the file and exit
10. Restart syslog: `/etc/init.d/syslog restart`

When Syslog is functioning you will see logs populated in: `/var/log/DSM.log`

Access events with Amazon SNS

Set up Amazon SNS

If you have an AWS account, you can take advantage of the Amazon Simple Notification Service (SNS) to publish notifications about Deep Security events and deliver them to subscribers. For details about SNS, see <https://aws.amazon.com/sns/>.

To set up Amazon SNS:

1. "Create an AWS user" below.
2. "Create an Amazon SNS topic" on the next page.
3. "Enable SNS" on the next page.
4. "Create subscriptions" on page 1216.

See the sections below for details on how to perform these tasks.

Create an AWS user

In order to use Amazon SNS with Deep Security, you need to create an AWS user with the appropriate permissions for SNS. Note the access key and secret key for the user, because you will need that information for step 3, below.

The AWS user will need the "sns:Publish" permission on all SNS topics that Deep Security will publish to. This is an example of a policy with this permission:

```
{
  "Version": "2012-10-17",
  "Statement": [
    {
      "Action": [
        "sns:Publish"
      ],
      "Effect": "Allow",
      "Resource": "*"
    }
  ]
}
```

If you want to limit publishing rights to a single topic, you can replace `"Resource": "*"` with `"Resource": "TOPIC ARN"`.

For more information, see [Controlling User Access to Your AWS Account](#) and [Special Information for Amazon SNS Policies](#) in the Amazon AWS documentation.

Create an Amazon SNS topic

In AWS, create an SNS topic where the events will be published. For instructions on how to create an Amazon SNS topic, see "Create a Topic" in the [Amazon SNS documentation](#). Note the SNS Topic ARN because you will need this information in step 3, below.

Enable SNS

1. In the Deep Security Manager, go to **Administration > System Settings > Event Forwarding**.
2. In the Amazon SNS section, select **Publish Events to Amazon Simple Notification Service**.
3. Enter this information:
 - **Access Key:** The access key of the AWS user you created in section 1.
 - **Secret Key:** The secret key of the AWS user you created in section 1.
 - **SNS Topic ARN:** The SNS Topic ARN that events will be sent to. This is the ARN that you noted in section 2.
4. Select the types of events that you want to forward to SNS.

Selecting the events automatically generates a JSON SNS configuration.

5. (Optional) You can also click **Edit JSON SNS configuration** to edit the JSON SNS configuration directly if you want to filter the events in greater detail and configure the forwarding instructions for each filter. For details on the configuration language, see ["SNS configuration in JSON format" on the next page](#).

Note: If you edit the JSON, the event check boxes will become unavailable. If you want to select or deselect any of the event check boxes, you can click **Revert to basic SNS configuration**, but any customizations you have made to the JSON SNS configuration will be discarded.

6. Click **Save**.

Create subscriptions

Now that SNS is enabled and events are being published to the topic, go to the Amazon SNS console and subscribe to the topic to access the events. There are several ways that you can subscribe to events, including [email](#), [SMS](#), and [Lambda endpoints](#).

Note: Lambda is not available in all AWS regions.

SNS configuration in JSON format

You can edit the [JSON](#) configuration that is used when you have [enabled event forwarding to Amazon SNS topics](#). It defines which conditions an event must meet in order to be published to a topic. The configuration language is modeled after [Amazon's Policy language for SNS](#).

Each field is specified below. Basic SNS configuration looks like:

```
{
  "Version": "2014-09-24",
  "Statement": [statement1, statement2, ...]
}
```

For examples, see ["Example SNS configurations" on page 1230](#).

Version

The **Version** element specifies the version of the configuration language.

Note: The only currently valid value of "Version" is the string "2014-09-24".

```
"Version": "2014-09-24",
```

Statement

The **Statement** element is an array of individual statements. Each individual statement is a distinct JSON object giving the SNS topic to send to if an event meets given conditions.

```
"Statement": [{...}, {...}, ...]
```

An individual statement has the form:

```
{
  "Topic": "destination topic",
  "Condition": {conditions event must meet to be published to the
destination topic}
}
```

Topic

The **Topic** element must be the Amazon Resource Name of the SNS Topic to publish to.

```
"Topic": "arn:aws:sns:us-east-1:012345678901:myTopic"
```

Condition

The **Condition** element is the most complex part of the configuration. It contains one or more conditions an event must match in order to be published to the topic.

Each condition can have one or more key-value pairs that the event must match (or not match, depending on the type of condition) to be included in the topic. Keys are any valid event property. (For event properties, see ["Events in JSON format" on page 1232](#)). Valid values vary by key. Some keys support multiple values.

```
"Condition": {
  "ConditionName": {
    "key1": [value1, value2],
    "key2": value3
  },
  "ConditionName2": {
    "key3": [value4]
  },
  ...
}
```

Valid condition names and their syntax are described below.

Bool

The **Bool** condition performs Boolean matching. To match, an event must have a property with the desired Boolean value. If the property in the event exists but is not itself a Boolean value, the property is tested as follows:

- Numbers equal to 0 evaluate to false. Numbers not equal to 0 evaluate to true.
- Empty strings and the special strings "false" and "0" evaluate to false. Other strings evaluate to true.
- Any other property value in an event cannot be converted to a Boolean and will not match.

Allows for multiple values? No

The following example shows a configuration that publishes events that have a "DetectOnly" property with a value false:

```
{
  "Version": "2014-09-24",
  "Statement": [
    {
      "Topic": "arn:aws:sns:us-east-1:012345678901:myTopic",
      "Condition": {
        "Bool": {
          "DetectOnly": false
        }
      }
    }
  ]
}
```

Exists

The **Exists** condition tests for the existence or non-existence of a property in an event. The value of the property is not considered.

Allows for multiple values? No

The following example shows a configuration that publishes events when the event has the property "Severity" but does not have the property "Title":

```
{
  "Version": "2014-09-24",
  "Statement": [
    {
      "Topic": "arn:aws:sns:us-east-1:012345678901:myTopic",
      "Condition": {
        "Exists": {
          "Severity": true,
          "Title": false
        }
      }
    }
  ]
}
```

IpAddress

The **IpAddress** condition tests the value of an event's property is an IP address in a range given in CIDR format, or exactly equals a single IP address.

Allows for multiple values? Yes

The following example shows a configuration that publishes events when the event has the property "DestinationIP" with an IP address in the range 10.0.1.0/24, or to 10.0.0.5:

```
{
  "Version": "2014-09-24",
  "Statement": [
    {
      "Topic": "arn:aws:sns:us-east-1:012345678901:myTopic",
      "Condition": {
        "IpAddress": {
          "DestinationIP": ["10.0.1.0/24", "10.0.0.5"]
        }
      }
    }
  ]
}
```

```

        }
    }
}
]
}

```

NotIpAddress

The **NotIpAddress** condition tests the value of an event's property is not an IP address in any of the specified IP address ranges.

Allows for multiple values? Yes

The following example shows a configuration that publishes events when the event has the property "DestinationIP" with an IP address not in the range 10.0.0.0/8:

```

{
  "Version": "2014-09-24",
  "Statement": [
    {
      "Topic": "arn:aws:sns:us-east-1:012345678901:myTopic",
      "Condition": {
        "NotIpAddress": {
          "DestinationIP": "10.0.0.0/8"
        }
      }
    }
  ]
}

```

NumericEquals

The **NumericEquals** condition tests the numeric value of an event's property equals one or more desired values. If the property in the event exists but is not itself a numeric value, the property is tested as follows:

- Strings are converted to numbers. Strings that cannot be converted to numbers will not match.
- Any other property value in an event cannot be converted to a number and will not match.

Allows for multiple values? Yes

The following example shows a configuration that publishes events when the event has the property "Protocol" with the value 6 or 17:

```
{
  "Version": "2014-09-24",
  "Statement": [
    {
      "Topic": "arn:aws:sns:us-east-1:012345678901:myTopic",
      "Condition": {
        "NumericEquals": {
          "Protocol": [6, 17]
        }
      }
    }
  ]
}
```

NumericNotEquals

The **NumericNotEquals** condition tests the numeric value of an event's property is not equal to any one of an undesired set of values.

Allows for multiple values? Yes

The following example shows a configuration that publishes events when the event has the property "Protocol" not equal to 6, and the property "Risk" not equal to 2 or 3:

```
{
  "Version": "2014-09-24",
  "Statement": [
    {
```

```
"Topic": "arn:aws:sns:us-east-1:012345678901:myTopic",
"Condition": {
  "NumericNotEquals": {
    "Protocol": 6,
    "Risk" : [2, 3]
  }
}
]
```

NumericGreaterThan

The **NumericGreaterThan** condition tests the numeric value of an event's property is strictly greater than a desired value. If the property in the event exists but is not itself a numeric value it is converted to a number as described for **NumericEquals**.

Allows for multiple values? No

The following example shows a configuration that publishes events when the event has the property "Protocol" with the value greater than 6:

```
{
  "Version": "2014-09-24",
  "Statement": [
    {
      "Topic": "arn:aws:sns:us-east-1:012345678901:myTopic",
      "Condition": {
        "NumericGreaterThan": {
          "Protocol": 6
        }
      }
    }
  ]
}
```

```
}
```

NumericGreaterThanEquals

The **NumericGreaterThanEquals** condition tests the numeric value of an event's property is greater than or equal to a desired value. If the property in the event exists but is not itself a numeric value it is converted to a number as described for **NumericEquals**.

Allows for multiple values? No

The following example shows a configuration that publishes events when the event has the property "Number" with a value greater than or equal to 600:

```
{
  "Version": "2014-09-24",
  "Statement": [
    {
      "Topic": "arn:aws:sns:us-east-1:012345678901:myTopic",
      "Condition": {
        "NumericGreaterThanEquals": {
          "Number": 600
        }
      }
    }
  ]
}
```

NumericLessThan

The **NumericLessThan** condition tests the numeric value of an event's property is strictly less than a desired value. If the property in the event exists but is not itself a numeric value it is converted to a number as described for **NumericEquals**.

Allows for multiple values? No

The following example shows a configuration that publishes events when the event has the property "Number" with a value greater than 1000:

```
{
  "Version": "2014-09-24",
  "Statement": [
    {
      "Topic": "arn:aws:sns:us-east-1:012345678901:myTopic",
      "Condition": {
        "NumericLessThan": {
          "Number": 1000
        }
      }
    }
  ]
}
```

NumericLessThanEquals

The **NumericLessThanEquals** condition tests the numeric value of an event's property is less than or equal to a desired value. If the property in the event exists but is not itself a numeric value it is converted to a number as described for **NumericEquals**.

Allows for multiple values? No

The following example shows a configuration that publishes events when the event has the property "Number" with a value less than or equal to 500:

```
{
  "Version": "2014-09-24",
  "Statement": [
    {
      "Topic": "arn:aws:sns:us-east-1:012345678901:myTopic",
      "Condition": {
        "NumericLessThanEquals": {
          "Number": 500
        }
      }
    }
  ]
}
```



```

        }
    }
}
]
}

```

StringEquals

The **StringEquals** condition tests the string value of an event's property is strictly equal to or more desired values.

Allows for multiple values? Yes

The following example shows a configuration that publishes events when the event has the property "EventType" equal to "SystemEvent" and property "TargetType" equal to "User" or "Role":

```

{
  "Version": "2014-09-24",
  "Statement": [
    {
      "Topic": "arn:aws:sns:us-east-1:012345678901:myTopic",
      "Condition": {
        "StringEquals": {
          "EventType": ["SystemEvent"],
          "TargetType" : ["User", "Role"]
        }
      }
    }
  ]
}

```

StringNotEquals

The **StringNotEquals** condition tests the string value of an event's property does not equal any of an undesired set of values.

Allows for multiple values? Yes

The following example shows a configuration that publishes events when the event has the property "EventType" not equal to "PacketLog" or "IntegrityEvent":

```
{
  "Version": "2014-09-24",
  "Statement": [
    {
      "Topic": "arn:aws:sns:us-east-1:012345678901:myTopic",
      "Condition": {
        "StringNotEquals": {
          "EventType": ["PacketLog", "IntegrityEvent"]
        }
      }
    }
  ]
}
```

StringEqualsIgnoreCase

The **StringEqualsIgnoreCase** condition is the same as the StringEquals condition, except string matching is performed in a case-insensitive manner.

StringNotEqualsIgnoreCase

The **StringNotEqualsIgnoreCase** condition is the same as the StringNotEquals condition, except string matching is performed in a case-insensitive manner.

StringLike

The **StringLike** condition tests the string value of an event's property is equal to or more desired values, where the desired values may include the wildcard '*' to match any number of characters or '?' to match a single character. String comparisons are case-sensitive.

Allows for multiple values? Yes

The following example shows a configuration that publishes events when the event has the property "Title" which contains the string "User" or "Role":

```
{
  "Version": "2014-09-24",
  "Statement": [
    {
      "Topic": "arn:aws:sns:us-east-1:012345678901:myTopic",
      "Condition": {
        "StringLike": {
          "Title": ["*User*", "*Role*"]
        }
      }
    }
  ]
}
```

StringNotLike

The **StringNotLike** condition tests that the string value of an event's property is not equal to any of an undesired set of values, where the values may include the wildcard '*' to match any number of characters or '?' to match a single character. String comparisons are case-sensitive.

Allows for multiple values? Yes

The following example shows a configuration that publishes all events except the "System Settings Saved" event:

```
{
  "Version": "2014-09-24",
```

```
"Statement": [  
  {  
    "Topic": "arn:aws:sns:us-east-1:012345678901:myTopic",  
    "Condition": {  
      "StringNotLike": {  
        "Title": "System Settings Saved"  
      }  
    }  
  }  
]
```

The next example shows a configuration that publishes events when the event has the property "Title" that does not start with "User" and does not end with "Created":

```
{  
  "Version": "2014-09-24",  
  "Statement": [  
    {  
      "Topic": "arn:aws:sns:us-east-1:012345678901:myTopic",  
      "Condition": {  
        "StringNotLike": {  
          "Title": ["User*", "*Created"]  
        }  
      }  
    }  
  ]  
}
```

Multiple statements vs. multiple conditions

If you create multiple statements for the same SNS topic, those statements are evaluated as if they are joined by "or". If a statement contains multiple conditions, those conditions are evaluated as if they are joined by "and".

Multiple statements

This is an example of what not to do. The first statement says to forward all events other than "System Settings Saved". The second statement says to forward all "System Settings Saved" events. The result is that all events will be forwarded because any event will match either the condition in the first statement **or** the one in the second statement:

```
{
  "Version": "2014-09-24",
  "Statement": [
    {
      "Topic": "arn:aws:sns:us-east-1:012345678901:myTopic",
      "Condition": {
        "StringNotLike" : {
          "Title" : "System Settings Saved"
        }
      }
    },
    {
      "Topic": "arn:aws:sns:us-east-1:012345678901:myTopic",
      "Condition": {
        "StringLike" : {
          "Title" : "System Settings Saved"
        }
      }
    }
  ]
}
```

Multiple conditions

This is another example of what not to do. The first condition says to forward all events other than "System Settings Saved". The second condition says to forward all "System Settings Saved" events. The result is that no events will be forwarded because no events will match both the condition in the first statement **and** the one in the second statement:

```

{
  "Version": "2014-09-24",
  "Statement": [
    {
      "Topic": "arn:aws:sns:us-east-1:012345678901:myTopic",
      "Condition": {
        "StringNotLike" : {
          "Title" : "System Settings Saved"
        },
        "StringLike" : {
          "Title" : "System Settings Saved"
        }
      }
    }
  ]
}

```

Example SNS configurations

These configurations send matching events for some specific scenarios. For more event property names and values that you can use to filter SNS topics, see ["Events in JSON format" on page 1232](#).

Send all critical intrusion prevention events to an SNS topic

```

{
  "Version": "2014-09-24",
  "Statement": [
    {
      "Topic": "arn:aws:sns:us-east-1:012345678901:myTopic",
      "Condition": {
        "NumericEquals": {
          "Severity": 4
        },
        "StringEquals" : {
          "EventType" : "PayloadLog"
        }
      }
    }
  ]
}

```

```
    }  
  }  
}  
]  
}
```

Send different events to different SNS topics

This example shows sending all system events to one topic and all integrity monitoring events to a different topic.

```
{  
  "Version": "2014-09-24",  
  "Statement": [  
    {  
      "Topic": "arn:aws:sns:us-east-  
1:012345678901:systemEventsTopic",  
      "Condition": {  
        "StringEquals" : {  
          "EventType" : "SystemEvent"  
        }  
      }  
    },  
    {  
      "Topic": "arn:aws:sns:us-east-  
1:012345678901:integrityTopic",  
      "Condition": {  
        "StringEquals" : {  
          "EventType" : "IntegrityEvent"  
        }  
      }  
    }  
  ]  
}
```

Events in JSON format

When published to Amazon SNS, events are sent in the SNS `Message` as an array of JSON objects that are encoded as strings. Each object in the array is one event.

Valid properties vary by the type of event. For example, `MajorVirusType` is a valid property only for Deep Security Anti-Malware events, not system events etc. Valid property values vary for each property. For examples, see ["Example events in JSON format" on page 1259](#).

Event property values can be used to filter which events are published to the SNS topic. For details, see ["SNS configuration in JSON format" on page 1216](#).

Valid event properties

Note: Some events don't have all of the properties that usually apply to their event type.

Property Name	Data Type	Description	Applies To Event Type(s)
ACRulesetID	Integer	The unique identifier of the Application Control Ruleset applied to the computer where the event was detected.	Application Control events
Action	String (enum)	Action taken for the application control event, such as "Execution of Software Blocked by Rule", "Execution of Unrecognized Software Allowed" (due to detect-only mode) or "Execution of Unrecognized Software Blocked".	Application Control events
Action	Integer (enum)	Action taken for the firewall event. "Detect Only" values show what would have happened if the rule had been enabled. 0=Unknown, 1=Deny, 6=Log Only, 0x81=Detect Only: Deny.	Firewall events
Action	Integer (enum)	Action taken for the Intrusion Prevention event. 0=Unknown, 1=Deny, 2=Reset, 3=Insert, 4=Delete, 5=Replace, 6=Log Only, 0x81=Detect Only: Deny, 0x82=Detect Only: Reset,	Intrusion Prevention events

Property Name	Data Type	Description	Applies To Event Type(s)
		0x83=Detect Only: Insert, 0x84=Detect Only: Delete, 0x85=Detect Only: Replace.	
ActionBy	String	Name of the Deep Security Manager user who performed the event, or "System" if the event was not generated by a user.	System events
ActionReasonDesc	String	The reason the Action was blocked.	Application Control events
ActionString	String	Conversion of Action to a readable string.	Firewall events, Intrusion Prevention events
AdministratorID	Integer	Unique identifier of the Deep Security user who performed an action. Events generated by the system and not by a user will not have an identifier.	System events
AggregationType	Integer (enum)	Whether or not the Application Control event occurred repeatedly. If "AggregationType" is not "0", then the number of occurrences is in "RepeatCount." 0=Not aggregated, 1=Aggregated based on file name, path and event type, 2=Aggregated based on event type	Application Control events
AMTarget	String	The file, process, or registry key (if any) that the malware was trying to affect. If the malware was trying to affect more than one, this field will contain the value "Multiple."	Anti-Malware events
AMTargetCount	Integer	The number of target files.	Anti-Malware events

Property Name	Data Type	Description	Applies To Event Type(s)
AMTargetType	Integer	The numeric code for the type of system resources that this malware was trying to affect. For the descriptive version, see AMTargetTypeString. 0=Unknown, 1=Process, 2=Registry, 3=File System, 4=Invoke, 5=Exploit, 6=API, 7=Memory, 8=Network Connection, 9=Uncategorized	Anti-Malware events
AMTargetTypeString	String	The type of system resource that this malware was trying to affect, such as the file system, a process, or Windows registry.	Anti-Malware events
ATSEDDetectionLevel	Integer	The detection level of document exploit protection.	Anti-Malware events
ApplicationType	String	Name of the network application type associated with the Intrusion Prevention rule, if available.	Intrusion Prevention events
BehaviorRuleId	String	The behavior monitoring rule ID for internal malware case tracking.	Anti-Malware events
BehaviorType	String	The type of behavior monitoring event detected.	Anti-Malware events
BlockReason	Integer (enum)	A reason that corresponds to the Action. 0=Unknown, 1=Blocked due to rule, 2=Blocked due to unrecognized	Application Control events
Change	Integer (enum)	What type of change was made to a file, process, registry key, etc. for an Integrity Monitoring event. 1=Created, 2=Updated, 3=Deleted, 4=Renamed.	Integrity Monitoring events
ChangeString	String	What type of change was made to a	Integrity

Property Name	Data Type	Description	Applies To Event Type(s)
		file, process, registry key, etc. for an Integrity Monitoring event: Created, Updated, Deleted, or Renamed.	Monitoring events
CommandLine	String	The commands that the subject process executed.	Anti-Malware events
ContainerID	String	ID of the container where the event occurred.	Anti-Malware events, Intrusion Prevention events, Firewall events
ContainerImageName	String	Image name of the Docker container where the malware was found.	Anti-Malware events
ContainerName	String	Name of the container where the event occurred.	Anti-Malware events, Intrusion Prevention events, Firewall events
CreationTime	String (Date)	The creation time of the infected file.	Anti-Malware events
Cve	String	The CVE information, if the process behavior is identified in one of Common Vulnerabilities and Exposures.	Anti-Malware events
DataIndex	Integer	A unique ID for packet data.	Intrusion Prevention events

Property Name	Data Type	Description	Applies To Event Type(s)
Description	String	Description of the change made to the entity (created, deleted, updated) along with details about the attributes changed.	Integrity Monitoring events
Description	String	Brief description of what happened during an event.	System events
DestinationIP	String (IP)	The IP address of the destination of a packet.	Firewall events, Intrusion Prevention events
DestinationMAC	String (MAC)	The MAC address of the destination of a packet.	Firewall events, Intrusion Prevention events
DestinationPort	Integer	The network port number a packet was sent to.	Firewall events, Intrusion Prevention events
DetectionCategory	Integer (enum)	The detection category for a web reputation event. 12=User Defined, 13=Custom, 91=Global.	Web Reputation events
DetectOnly	Boolean	Whether or not the event was returned with the Detect Only flag turned on. If true, this indicates that the URL was not blocked, but access was detected.	Web Reputation events
Direction	Integer (enum)	Network packet direction. 0=Incoming, 1=Outgoing.	Firewall events, Intrusion Prevention events
DirectionString	String	Conversion Direction to a readable	Firewall

Property Name	Data Type	Description	Applies To Event Type(s)
		string.	events, Intrusion Prevention events
DriverTime	Integer	The time the log was generated as recorded by the driver.	Firewall events, Intrusion Prevention events
EndLogDate	String (Date)	The last log date recorded for repeated events. Will not be present for events that did not repeat.	Firewall events, Intrusion Prevention events
EngineType	Integer	The Anti-Malware engine type.	Anti-Malware events
EngineVersion	String	The Anti-Malware engine version.	Anti-Malware events
EntityType	String (enum)	The type of entity an integrity monitoring event applies to: Directory, File, Group, InstalledSoftware, Port, Process, RegistryKey, RegistryValue, Service, User, or Wql	Integrity Monitoring events
ErrorCode	Integer	Error code for malware scanning events. If non-zero the scan failed, and the scan action and scan result fields contain more details.	Anti-Malware events
EventID	Integer	The identifier of the event. Identifiers are unique per event type, but events of different types may share the same identifier. For example, it is possible for events with both EventType firewall and ips to have EventID	All event types

Property Name	Data Type	Description	Applies To Event Type(s)
		equal to 1. The combination of EventID, EventType and TenantID are required to completely, uniquely identify an event in Deep Security. Note that this property is not related to the "Event ID" property of a System Event in the Deep Security Manager.	
EventType	String (enum)	The type of the event. One of: "SystemEvent", "PacketLog", "PayloadLog", "AntiMalwareEvent", "WebReputationEvent", "IntegrityEvent", "LogInspectionEvent", "AppControlEvent".	All event types
FileName	String	File name of the software that was allowed or blocked, such as "script.sh". (The full path is separate, in "Path".)	Application Control events
FileSHA1	String	The filesha1 (Secure Hash Algorithm 1 result) of the infected file.	Anti-Malware events
FileSHA256	String	The filesha256 of the infected file.	Anti-Malware events
FileSize	Integer	File size of the software that was allowed or blocked	Application Control events
Flags	String	Flags recorded from a network packet; a space-separated list of strings.	Firewall events, Intrusion Prevention events
Flow	Integer (enum)	Network connection flow. Possible values: -1=Not Applicable, 0=Connection Flow, 1=Reverse Flow	Firewall events, Intrusion

Property Name	Data Type	Description	Applies To Event Type(s)
			Prevention events
FlowString	String	Conversion of Flow to a readable string.	Firewall events, Intrusion Prevention events
ForwardedSrc	Array (Byte)	The source information of a forwarded packet	Intrusion Prevention events
Frame	Integer (enum)	Frame type. -1=Unknown, 2048=IP, 2054=ARP, 32821=REVARP, 33169=NETBEUI, 0x86DD=IPv6	Firewall events, Intrusion Prevention events
FrameString	String	Conversion of Frame to a readable string.	Firewall events, Intrusion Prevention events
GroupID	String	The group ID, if any, of the user account that tried to start the software, such as "0".	Application Control events
GroupName	String	The group name, if any, of the user account that tried to start the software, such as "root".	Application Control events
HostAgentVersion	String	The version of the Deep Security Agent that was protecting the computer where the event was detected.	Application Control events, Anti-Malware events, Web Reputation events, Integrity

Property Name	Data Type	Description	Applies To Event Type(s)
			Monitoring events, Log Inspection events, Firewall events, Intrusion Prevention events
HostAgentGUID	String	The global unique identifier (GUID) of the Deep Security Agent when activated with the Deep Security Manager.	Anti-Malware events, Application Control events, Firewall events, Integrity Monitoring events, Intrusion Prevention events, Log Inspection events, Web Reputation events
HostAssetValue	Integer	The asset value assigned to the computer at the time the event was generated.	Anti-Malware events, Web Reputation events, Integrity Monitoring events, Log Inspection events, Firewall events, Intrusion Prevention

Property Name	Data Type	Description	Applies To Event Type(s)
			events, Application Control events
HostCloudType	String	The cloud service provider where the Deep Security Agent is hosted.	Anti-Malware events, Application Control events, Firewall events, Integrity Monitoring events, Intrusion Prevention events, Log Inspection events, Web Reputation events
HostGUID	String	The global unique identifier (GUID) of the Deep Security Agent.	Anti-Malware events, Application Control events, Firewall events, Integrity Monitoring events, Intrusion Prevention events, Log Inspection events, Web Reputation events

Property Name	Data Type	Description	Applies To Event Type(s)
HostGroupID	Integer	The unique identifier of the Computer Group of the computer where the event was detected.	Application Control events, Anti-Malware events, Web Reputation events, Integrity Monitoring events, Log Inspection events, Firewall events, Intrusion Prevention events
HostGroupName	String	The name of the Computer Group of the computer where the event was detected. Note that Computer Group names may not be unique.	Application Control events, Anti-Malware events, Web Reputation events, Integrity Monitoring events, Log Inspection events, Firewall events, Intrusion Prevention events
HostID	Integer	Unique identifier of the computer where the event occurred.	Anti-Malware events, Web

Property Name	Data Type	Description	Applies To Event Type(s)
			Reputation events, Integrity Monitoring events, Log Inspection events, Firewall events, Intrusion Prevention events, Application Control events
HostInstanceID	String	The cloud instance ID of the computer where the event was detected. This property will only be set for computers synchronized with a Cloud Connector.	Application Control events, Anti-Malware events, Web Reputation events, Integrity Monitoring events, Log Inspection events, Firewall events, Intrusion Prevention events
HostLastIPUsed	String (IP)	The latest IP address updated from the agent when communicated to Deep Security Manager.	Anti-Malware events, Application Control events, Firewall events,

Property Name	Data Type	Description	Applies To Event Type(s)
			Integrity Monitoring events, Intrusion Prevention events, Log Inspection events, Web Reputation events
Hostname	String	Hostname of the computer on which the event was generated.	Anti-Malware events, Web Reputation events, Integrity Monitoring events, Log Inspection events, Firewall events, Intrusion Prevention events, Application Control events
HostOS	String	The operating system of the computer where the event was detected.	Anti-Malware events, Web Reputation events, Integrity Monitoring events, Log Inspection events, Firewall events,

Property Name	Data Type	Description	Applies To Event Type(s)
			Intrusion Prevention events, Application Control events
HostOwnerID	String	The cloud account ID of the computer where the event was detected. This property will only be set for computers synchronized with a Cloud Connector.	Application Control events, Anti-Malware events, Web Reputation events, Integrity Monitoring events, Log Inspection events, Firewall events, Intrusion Prevention events
HostSecurityPolicyID	Integer	The unique identifier of the Deep Security policy applied to the computer where the event was detected.	Anti-Malware events, Web Reputation events, Integrity Monitoring events, Log Inspection events, Firewall events, Intrusion Prevention events, Application Control

Property Name	Data Type	Description	Applies To Event Type(s)
			events
HostSecurityPolicyName	String	The name of the Deep Security policy applied to the computer where the event was detected. Note that security policy names may not be unique.	Anti-Malware events, Web Reputation events, Integrity Monitoring events, Log Inspection events, Firewall events, Intrusion Prevention events, Application Control events
HostVCUID	String	The vCenter UUID of the computer the event applies to, if known.	Application Control events, Anti-Malware events, Web Reputation events, Integrity Monitoring events, Log Inspection events, Firewall events, Intrusion Prevention events
ImageDigest	String	A unique summary of data used to identify the container image.	Intrusion Prevention events,

Property Name	Data Type	Description	Applies To Event Type(s)
			Firewall events
ImageID	String	Image ID of the Docker container where the event occurred	Intrusion Prevention events
ImageName	String	Image name that was used to create the container where the event occurred.	Intrusion Prevention events, Firewall events
InfectedFilePath	String	Path of the infected file in the case of malware detection.	Anti-Malware events
InfectionSource	String	The name of the computer that's the source of a malware infection, if known.	Anti-Malware events
Interface	String (MAC)	MAC address of the network interface sending or receiving a packet.	Firewall events, Intrusion Prevention events
InterfaceType	String	Container interface type. 0=physical interfaces belong to host that can be controlled separately in Deep Security Manager, 1=all virtual interfaces, 7=unknown type (typically the host interface).	Intrusion Prevention events, Firewall events
IPDatagramLength	Integer	The length of the IP datagram.	Intrusion Prevention events
IsHash	String	The SHA-1 content hash (hexadecimal encoded) of the file after it was modified.	Integrity Monitoring events
Key	String	The file or registry key an integrity	Integrity

Property Name	Data Type	Description	Applies To Event Type(s)
		event refers to.	Monitoring events
LogDate	String (Date)	The date and time when the event was recorded. For Deep Security Agent-generated events (Firewall, IPS, etc.), the time is when the event was recorded by the agent, not when the event was received by Deep Security Manager.	All event types
MajorVirusType	Integer (enum)	The classification of malware detected. 0=Joke, 1=Trojan, 2=Virus, 3=Test, 4=Spyware, 5=Packer, 6=Generic, 7=Other	Anti-Malware events
MajorVirusTypeString	String	Conversion of MajorVirusType to a readable string.	Anti-Malware events
MalwareName	String	The name of the malware detected.	Anti-Malware events
MalwareType	Integer (enum)	The type of malware detected. 1=General malware, 2=Spyware. General malware events will have an InfectedFilePath, spyware events will not.	Anti-Malware events
ManagerNodeID	Integer	Unique identifier of the Deep Security Manager Node where the event was generated.	System events
ManagerNodeName	String	Name of the Deep Security Manager Node where the event was generated.	System events
MD5	String	The MD5 checksum (hash) of the software, if any.	Application Control events
Mitre	String	The MITRE information, if the	Anti-

Property Name	Data Type	Description	Applies To Event Type(s)
		process behavior is identified in one of MITRE attack scenarios.	Malware events
ModificationTime	String (Date)	The modification time of the infected file.	Anti-Malware events
Note	Array (Byte)	Encoded note about the packet where the event occurred.	Intrusion Prevention events
Number	Integer	System events have an additional ID that identifies the event. Note that in the Deep Security Manager, this property appears as "Event ID".	System events
Operation	Integer (enum)	0=Unknown, 1=Allowed due to detect-only mode, 2=Blocked	Application control
OperationDesc	String	Describes the Operation value	Application Control events
Origin	Integer (enum)	The origin of the event. -1=Unknown, 0=Deep Security Agent, 1=In-VM guest agent, 2=Deep Security Appliance, 3=Deep Security Manager	All event types
OriginString	String	Conversion of Origin to a human-readable string.	All event types
OSSEC_Action	String	OSSEC action	Log Inspection events
OSSEC_Command	String	OSSEC command	Log Inspection events
OSSEC_Data	String	OSSEC data	Log Inspection events

Property Name	Data Type	Description	Applies To Event Type(s)
OSSEC_Description	String	OSSEC description	Log Inspection events
OSSEC_DestinationIP	String	OSSEC dstip	Log Inspection events
OSSEC_DestinationPort	String	OSSEC dstport	Log Inspection events
OSSEC_DestinationUser	String	OSSEC dstuser	Log Inspection events
OSSEC_FullLog	String	OSSEC full log	Log Inspection events
OSSEC_Groups	String	OSSEC groups result (e.g. syslog,authentication_failure)	Log Inspection events
OSSEC_Hostname	String	OSSEC hostname. This is the name of the host as read from a log entry, which is not necessarily the same as the name of the host on which the event was generated.	Log Inspection events
OSSEC_ID	String	OSSEC id	Log Inspection events
OSSEC_Level	Integer (enum)	OSSEC level. An integer in the range 0 to 15 inclusive. 0-3=Low severity, 4-7=Medium severity, 8-11=High severity, 12-15=Critical severity.	Log Inspection events
OSSEC_Location	String	OSSEC location	Log Inspection events

Property Name	Data Type	Description	Applies To Event Type(s)
OSSEC_Log	String	OSSEC log	Log Inspection events
OSSEC_ProgramName	String	OSSEC program_name	Log Inspection events
OSSEC_Protocol	String	OSSEC protocol	Log Inspection events
OSSEC_RuleID	Integer	OSSEC rule id	Log Inspection events
OSSEC_SourceIP	Integer	OSSEC srcip	Log Inspection events
OSSEC_SourcePort	Integer	OSSEC srcport	Log Inspection events
OSSEC_SourceUser	Integer	OSSEC srcuser	Log Inspection events
OSSEC_Status	Integer	OSSEC status	Log Inspection events
OSSEC_SystemName	Integer	OSSEC systemname	Log Inspection events
OSSEC_URL	Integer	OSSEC url	Log Inspection events
PacketData	Integer	Hexadecimal encoding of captured packet data, if the rule was configured to capture packet data.	Intrusion Prevention events

Property Name	Data Type	Description	Applies To Event Type(s)
PacketSize	Integer	The size of the network packet.	Firewall events
Path	String	Directory path of the software file that was allowed or blocked, such as "/usr/bin/". (The file name is separate, in "FileName".)	Application Control events
PatternVersion	Integer (enum)	The malware detection pattern version.	Anti-Malware events
PayloadFlags	Integer	Intrusion Prevention Filter Flags. A bitmask value that can include the following flag values: 1 - Data truncated - Data could not be logged. 2 - Log Overflow - Log overflowed after this log. 4 - Suppressed - Logs threshold suppressed after this log. 8 - Have Data - Contains packet data. 16 - Reference Data - References previously logged data.	Intrusion Prevention events
PodID	String	Pod unique ID (UID)	Intrusion Prevention events, Firewall events
PosInBuffer	Integer	Position within packet of data that triggered the event.	Intrusion Prevention events
PosInStream	Integer	Position within stream of data that triggered the event.	Intrusion Prevention events
Process	String	The name of the process that generated the event, if available.	Integrity Monitoring events
ProcessID	Integer	The identifier (PID) of the process that generated the event, if available.	Application Control

Property Name	Data Type	Description	Applies To Event Type(s)
			events, Intrusion Prevention events, Firewall events
Process	String	The process name of behavior monitoring event detected.	Anti-Malware events
ProcessName	String	The name of the process that generated the event, if available, such as "/usr/bin/bash".	Application Control events, Intrusion Prevention events, Firewall events
Protocol	Integer (enum)	The numerical network protocol identifier. -1=Unknown, 1=ICMP, 2=IGMP, 3=GGP, 6=TCP, 12=PUP, 17=UDP, 22=IDP, 58=ICMPv6, 77=ND, 255=RAW	Firewall events, Intrusion Prevention events
Protocol	Integer	The numerical value for the file scan protocol. 0=Local file	Anti-Malware events
ProtocolString	String	Conversion of Protocol to a readable string.	Firewall events, Intrusion Prevention events
Rank	Integer	The numerical rank of the event; the product of the computer's assigned asset value and the severity value setting for an event of this severity.	Integrity Monitoring events, Log Inspection events, Firewall events, Intrusion

Property Name	Data Type	Description	Applies To Event Type(s)
			Prevention events
Reason	String	Name of the Deep Security rule or configuration object that triggered the event, or (for Firewall and Intrusion Prevention) a mapping of Status to String if the event was not triggered by a rule. For Application Control, "Reason" may be "None"; see "BlockReason" instead.	Firewall, Intrusion Prevention, Integrity Monitoring, Log Inspection, Anti-Malware, and Application Control events
RepeatCount	Integer	The number of times this event occurred repeatedly. A repeat count of 1 indicates the event was only observed once and did not repeat.	Firewall events, Intrusion Prevention events, Application Control events
Risk	Integer (enum)	Translated risk level of the URL accessed. 2=Suspicious, 3=Highly Suspicious, 4=Dangerous, 5=Untested, 6=Blocked by Administrator	Web Reputation events
RiskLevel	Integer	The raw risk level of the URL from 0 to 100. Will not be present if the URL was blocked by a block rule.	Web Reputation events
RiskString	String	Conversion of Risk to a readable string.	Web Reputation events
ScanAction1	Integer	Scan action 1. Scan action 1 & 2 and scan result actions 1 & 2 and ErrorCode are combined to form the single "summaryScanResult".	Anti-Malware events

Property Name	Data Type	Description	Applies To Event Type(s)
ScanAction2	Integer	Scan action 2.	Anti-Malware events
ScanResultAction1	Integer	Scan result action 1.	Anti-Malware events
ScanResultAction2	Integer	Scan result action 2.	Anti-Malware events
ScanResultString	String	Malware scan result, as a string. A combination of ScanAction 1 and 2, ScanActionResult 1 and 2, and ErrorCode.	Anti-Malware events
ScanType	Integer (enum)	Malware scan type that created the event. 0=Real-Time, 1=Manual, 2=Scheduled, 3=Quick Scan	Anti-Malware events
ScanTypeString	String	Conversion of ScanType to a readable string.	Anti-Malware events
Severity	Integer	1=Info, 2=Warning, 3=Error	System events
Severity	Integer (enum)	1=Low, 2=Medium, 3=High, 4=Critical	Integrity Monitoring events, Intrusion Prevention events
SeverityString	String	Conversion of Severity to a human-readable string.	System events, Integrity Monitoring events, Intrusion Prevention events

Property Name	Data Type	Description	Applies To Event Type(s)
SeverityString	String	Conversion of OSSEC_Level to a human-readable string.	Log Inspection events
SHA1	String	The SHA-1 checksum (hash) of the software, if any.	Application Control events
SHA256	String	The SHA-256 checksum (hash) of the software, if any.	Application Control events
SourceIP	String (IP)	The source IP address of a packet.	Firewall events, Intrusion Prevention events
SourceMAC	String (MAC)	The source MAC Address of the packet.	Firewall events, Intrusion Prevention events
SourcePort	Integer	The network source port number of the packet.	Firewall events, Intrusion Prevention events
Status	Integer	If this event was not generated by a specific Firewall rule, then this status is one of approximately 50 hard-coded rules, such as 123=Out Of Allowed Policy	Firewall events
Status	Integer	If this event was not generated by a specific IPS rule, then this status is one of approximately 50 hard-coded reasons, such as -504=Invalid UTF8 encoding	Intrusion Prevention events
Tags	String	Comma-separated list of tags that	All event

Property Name	Data Type	Description	Applies To Event Type(s)
		have been applied to the event. This list will only include tags that are automatically applied when the event is generated.	types
TagSetID	Integer	Identifier of the group of tags that was applied to the event.	All event types
TargetID	Integer	Unique identifier of the target of the event. This identifier is unique for the targets of the same type within a tenant. It is possible for target IDs to be reused across different types, for example, both a Computer and a Policy may have target ID 10.	System events
TargetIP	String (IP)	IP Address that was being contacted when a Web Reputation Event was generated.	Web Reputation events
TargetName	String	The name of the target of the event. The target of a system event can be many things, including computers, policies, users, roles, and tasks.	System events
TargetType	String	The type of the target of the event.	System events
TenantGUID	String	The global unique identifier (GUID) of the tenant associated with the event.	All event types
TenantID	Integer	Unique identifier of the tenant associated with the event.	All event types
TenantName	String	Name of the tenant associated with the event.	All event types
ThreadID	String	ID of the thread (from the container) that caused the event.	Intrusion Prevention events, Firewall events

Property Name	Data Type	Description	Applies To Event Type(s)
Title	String	Title of the event.	System events
URL	String (URL)	The URL being accessed that generated the event.	Web Reputation events
User	String	The user account that was the target of an integrity monitoring event, if known.	Integrity Monitoring events
UserID	String	The user identifier (UID), if any, of the user account that tried to start the software, such as "0".	Application Control events
UserName	String	For Anti-Malware events, this is the user account name who triggered the event. For Application Control events, this is the user name, if any, of the user account that tried to start the software, such as "root".	Anti-Malware events, Application Control events

Data types of event properties

Events forwarded as JSON usually use strings to encode other data types.

Data Type	Description
Array (Byte)	JSON <code>array</code> , composed of byte values.
Boolean	JSON <code>true</code> or <code>false</code> .
Integer	JSON <code>int</code> . Deep Security does not output floating point numbers in events. Note: Integers in events may be more than 32 bits. Verify the code that processes events can handle this. For example, JavaScript's Number data type cannot safely handle larger than 32-bit integers .

Data Type	Description
Integer (enum)	JSON <code>int</code> , restricted to a set of enumerated values.
String	JSON <code>string</code> .
String (Date)	JSON <code>string</code> , formatted as a date and time in the pattern YYYY-MM-DDThh:mm:ss.sssZ (ISO 8601). 'Z' is the time zone. 'sss' are the three digits for sub-seconds. See also the W3C note on date and time formats .
String (IP)	JSON <code>string</code> , formatted as an IPv4 or IPv6 address.
String (MAC)	JSON <code>string</code> , formatted as a network MAC address.
String (URL)	JSON <code>string</code> , formatted as a URL.
String (enum)	JSON <code>string</code> , restricted to a set of enumerated values.

Example events in JSON format

System event

```
{
  "Type" : "Notification",
  "MessageId" : "123abc-123-123-123-123abc",
  "TopicArn" : "arn:aws:sns:us-west-2:123456789:DS_
Events",
  "Message" : "[
    {
      "ActionBy": "System",
      "Description": "Alert: New Pattern
Update is Downloaded and Available\\nSeverity: Warning\\",
      "EventID": 6813,
      "EventType": "SystemEvent",
      "LogDate": "2018-12-04T15:54:24.086Z",
```

```

        "ManagerNodeID":123,
        "ManagerNodeName":"job7-123",
        "Number":192,
        "Origin":3,
        "OriginString":"Manager",
        "Severity":1,
        "SeverityString":"Info",
        "Tags":"\",
        "TargetID":1,
        "TargetName":"ec2-12-123-123-123.us-
west-2.compute.amazonaws.com",
        "TargetType":"Host",
        "TenantID":123,
        "TenantName":"Umbrella Corp.",
        "Title":"Alert Ended"
    }
],
"Timestamp" : "2018-12-04T15:54:25.130Z",
"SignatureVersion" : "1",
"Signature" : "500PER10NG5!gnaTURE==",
"SigningCertURL" : "https://sns.us-west-
2.amazonaws.com/SimpleNotificationService-abc123.pem",
"UnsubscribeURL" : "https://sns.us-west-
2.amazonaws.com/?Action=Unsubscribe&SubscriptionArn=arn:aws:sns:u
s-west-2:123456:DS_Events:123abc-123-123-123-123abc"
}

```

Anti-Malware events

Multiple virus detection events can be in each SNS `Message`. (For brevity, repeated event properties are omitted below, indicated by "...".)

```

{
  "Type" : "Notification",

```

```

    "MessageId" :      "123abc-123-123-123-123abc",
    "TopicArn" :      "arn:aws:sns:us-west-2:123456789:DS_
Events",
    "Message" :      "[
                        {
                          "AMTarget": "VDSO memory",
                          "AMTargetCount": 1,
                          "AMTargetType": 7,
                          "AMTargetTypeString": "Memory",
                          "ATSEDetectionLevel": 0,
                          "BehaviorRuleId": "DIRTYCOW_MADVISE_
EXPL",
                          "BehaviorType": "Exploit_Detection",
                          "CommandLine": "/tmp/demo -f esiv
[xxxx]",
                          "Cve": "CVE-2016-5195",
                          "ErrorCode": 0,
                          "EventID": 1179519,
                          "EventType": "AntiMalwareEvent",
                          "FileSHA1":
"CEF4644713633C0864D4283FEFA0CE174D48F115",
                          "HostAgentGUID": "FF8162DF-4CB5-B158-
DE42-EBD52967FCF7",
                          "HostAgentVersion": "20.0.0.1685",
                          "HostGUID": "9089E800-41D3-2CA9-FF0B-
3A30A42ED650",
                          "HostID": 38,
                          "HostLastIPUsed": "172.31.21.47",
                          "HostOS": "Red Hat Enterprise 7 (64
bit) (3.10.0-957.12.2.el7.x86_64)",
                          "HostSecurityPolicyID": 11,
                          "HostSecurityPolicyName": "Linux_AM_
Sensor",

```

```

        "Hostname": "ec2-3-131-151-239.us-east-
2.compute.amazonaws.com",
        "InfectedFilePath": "/tmp/demo",
        "LogDate": "2021-01-07T10:32:11.000Z",
        "MajorVirusType": 14,
        "MajorVirusTypeString": "Suspicious
Activity",
        "MalwareName": "TM_MALWARE_BEHAVIOR",
        "MalwareType": 4,
        "Mitre": "T1068",
        "Origin": 0,
        "OriginString": "Agent",
        "PatternVersion": "1.2.1189",
        "Process": "testsys_m64",
        "Protocol": 0,
        "Reason": "Default Real-Time Scan
Configuration",
        "ScanAction1": 1,
        "ScanAction2": 0,
        "ScanResultAction1": 0,
        "ScanResultAction2": 0,
        "ScanResultString": "Passed",
        "ScanType": 0,
        "ScanTypeString": "Real Time",
        "Tags": "",
        "TenantGUID": "",
        "TenantID": 0,
        "TenantName": "Primary",
        "UserName": "root"
    }
]",
"Timestamp" : "2018-12-04T15:57:50.833Z",
"SignatureVersion" : "1",

```

```
"Signature" : "500PER10NG5!gnaTURE==",
"SigningCertURL" : "https://sns.us-west-
2.amazonaws.com/SimpleNotificationService-abc123.pem",
"UnsubscribeURL" : "https://sns.us-west-
2.amazonaws.com/?Action=Unsubscribe&SubscriptionArn=arn:aws:sns:u
s-west-2:123456:DS_Events:123abc-123-123-123-123abc"
}
```

Forward system events to a remote computer via SNMP

Deep Security supports SNMP for forwarding system events to a computer from Deep Security Manager. On Windows, the MIB file ("DeepSecurity.mib") is located in \Trend Micro\Deep Security Manager\util. On Linux, the default location is /opt/dsm/util.

Configure alerts

Alerts are generated when Deep Security requires your attention, such as an administrator-issued command failing, or a hard disk running out of space. Deep Security includes a pre-defined set of alerts (for a list, see ["Predefined alerts" on page 1274](#)). Additionally, when you create protection module rules, you can configure them to generate alerts if they are triggered.

There are several ways to see which alerts have been triggered:

- They're displayed in the "Alert Status" dashboard widget in Deep Security Manager.
- They're displayed on the Alerts page in Deep Security Manager (see ["View alerts in Deep Security Manager" on the next page](#)).
- You can get an email notification when an alert is triggered (see ["Set up email notification for alerts" on page 1265](#).)
- You can generate alert reports (see ["Generate reports about alerts and other activity" on page 1270](#)).

Unlike security events and system events, alerts are not purged from the database after a period of time. Alerts remain until they are dismissed, either manually or automatically.

View alerts in Deep Security Manager

The **Alerts** page in Deep Security Manager displays all alerts that have been triggered, but not yet responded to. You can display alerts in a summary view that groups similar alerts together, or in list view, which lists all alerts individually. To switch between the two views, use the menu next to "Alerts" in the page's title. You can also sort the alerts by time or by severity.

In summary view, expanding an Alert panel (by clicking **Show Details**) displays all the computers (or users) that have generated that particular alert. Clicking the computer will display the computer's **Details** window. If an alert applies to more than five computers, an ellipsis ("...") appears after the fifth computer. Clicking the ellipsis displays the full list. Once you have taken the appropriate action to deal with an alert, you can dismiss the alert by selecting the check box next to the target of the alert and clicking **Dismiss**. (In list view, right-click the alert to see the list of options in the context menu.)

Alerts that can't be dismissed (like "Relay Update Service Not Available") will be dismissed automatically when the condition no longer exists.

Note: In cases where an alert condition occurs more than once on the same computer, the alert will show the timestamp of the first occurrence of the condition. If the alert is dismissed and the condition reoccurs, the timestamp of the first re-occurrence will be displayed.

Tip: Use the Computers filtering bar to view only alerts for computers in a particular computer group, with a particular policy, etc.

Unlike security events and system events, alerts are not purged from the database after a period of time. Alerts remain until they are dismissed, either manually or automatically.

Configure alert settings

To configure the settings for individual alerts, go to the **Alerts** page in Deep Security Manager and click **Configure Alerts**. This displays a list of all alerts. A green check mark next to an alert indicates that it is enabled. An alert will be triggered if the corresponding situation occurs, and it will appear in the Deep Security Manager.

You can select an alert and click **Properties** to change other settings for the alert, such as the severity level and email notification settings.

Set up email notification for alerts

Deep Security Manager can send emails to specific users when selected alerts are triggered.

To enable email notifications:

1. Give Deep Security Manager access to an SMTP mail server (see ["Configure SMTP settings for email notifications" on page 1269](#)).
2. Specify which alerts cause email notifications to be sent. For example, you can send email only for the most critical alerts. Most alerts send email notifications by default. (see ["Turn alert emails on or off" on the next page](#)).
3. Specify who will receive email notifications. You can configure user accounts so that they receive alert emails (see ["Configure an individual user to receive alert emails" on page 1268](#)). You can also configure alerts to specify the email account of a user or a distribution list. With this option, email is sent regardless of the configuration of the user accounts (see ["Configure recipients for all alert emails" on page 1269](#)).

Turn alert emails on or off

1. Go to the Alerts page and click **Configure Alerts** to display the list of alerts.

Alert Configuration		No Grouping ▾
☰ Properties...		
ALERT ▾	SEVERITY	ON
Abnormal Restart Detected	Warning	✓
Activation Failed	Critical	✓
Agent configuration package too large	Warning	✓
Agent Installation Failed	Critical	✓
Agent Upgrade Recommended (Incompatible with Appliance)	Warning	✓
Agent/Appliance Upgrade Recommended	Warning	✓
Agent/Appliance Upgrade Recommended (Incompatible Security U...	Warning	✓
Agent/Appliance Upgrade Recommended (New Version Available)	Warning	✓
Agent/Appliance Upgrade Required	Warning	✓
An update to the Rules is available	Warning	✓
Anti-Malware Alert	Warning	✓
Anti-Malware Component Failure	Critical	✓
Anti-Malware Component Update Failed	Warning	✓
Anti-Malware Engine Offline	Critical	✓
Anti-Malware protection is absent or out of date	Warning	✓
Anti-Malware Quarantine Alert for Storage Limit	Warning	✓
Application Control Engine Offline	Critical	✓
Application Type Misconfiguration	Warning	✓
Application Type Recommendation	Warning	
Azure AD Application Need Renew	Critical	✓
Azure AD Application Password Expires Soon	Warning	✓
Azure Key Pair Expired	Critical	✓
Azure Key Pair Expires Soon	Warning	✓

Item 1 to 100 of 104 ⏪ ⏩

2. A green check mark next to an alert indicates that it is enabled. An alert will be triggered if the corresponding situation occurs, and appear in the Deep Security Manager GUI. If you also want to receive email about the alert, double-click on an alert to display its Properties window, then select at least one of the "Send Email" check boxes.

General

Alert Information

Alert: Anti-Malware Alert

Description: A Malware Scan Configuration that is configured for alerting has raised an event on one or more computers.

Dismissible: Yes

On
When on, the alert will be raised when the conditions are met.

Options

Severity: Warning

Alert for all rules (Regardless of rule settings)

Send Email to notify when this alert is raised.

Send Email to notify when conditions for this alert change (such as the # of items).

Send Email to notify when this alert no longer exists.

Off
When off, the alert will not be raised. Use this setting if you do not wish this condition to raise an alert.

OK Cancel Apply

Configure an individual user to receive alert emails

1. Go to **Administration > User Management > Users** and double-click a user account to display its Properties window.
2. On the **Contact Information** tab, enter an email address and select **Receive Alert Emails**.

Configure recipients for all alert emails

Note: All alert emails will be sent to this address or email distribution list, even if the recipients have not been set up in their user account properties to receive email notifications.

1. Go to **Administration > System Settings > Alerts**.
2. For **Alert Email Address - The email address to which all alert emails should be sent**, provide an email address or a distribution list email address.

Configure SMTP settings for email notifications

Deep Security Manager can send emails to users when selected alerts are triggered (see "[Configure alerts](#)" on page 1263). Before setting up the email notifications, you will need to give Deep Security Manager access to an SMTP mail server.

1. Go to **Administration > System Settings > SMTP**.
2. Type the IP address or hostname of your SMTP email server. Include the port number if it's not the [default port number](#).

Tip:

AWS throttles (rate limits) e-mail on SMTP's IANA standard port number, port 25. If you use AWS Marketplace, you may have faster alerts if you use SMTP over STARTTLS (secure SMTP) instead. For more information, see:

<https://docs.aws.amazon.com/ses/latest/DeveloperGuide/smtp-connect.html>

3. Enter a "From" email address from which the emails should be sent.

Note:

If you are using Amazon SES, the sender email address must be verified. To learn how to verify your email address in Amazon SES and view a list of addresses you've already verified, see:

<https://docs.aws.amazon.com/ses/latest/DeveloperGuide/verify-email-addresses.html>

4. Optionally, type a "bounce" address to which delivery failure notifications (DSN) should be sent if the alert emails can't be delivered to one or more users.
5. If your SMTP mail server requires outgoing authentication, type the user name and password credentials.

6. Select **STARTTLS** if your SMTP server supports the protocol. (STARTTLS is only supported in FIPS mode as of Deep Security Manager 20 LTS Update 2022-03-22. See ["FIPS 140 support" on page 1811.](#))
7. After you've entered the necessary information, click **Test SMTP Settings** to test the connection.

Generate reports about alerts and other activity

Deep Security Manager produces reports in PDF or RTF formats. Most of the reports have configurable parameters such as date range or reporting by computer group. Parameter options are disabled for reports to which they do not apply. You can set up a one-time report (see ["Set up a single report" below](#)) or set up a schedule to run a report on a regular basis (see ["Set up a scheduled report " on page 1273](#)).

Set up a single report

1. In the Deep Security Manager, go to the **Events & Reports** tab and then in the left pane, click **Generate Reports > Single Report**.
2. In the **Report** list, select the type of report that you want to generate. Depending on which protection modules you are using, the following reports may be available:
 - **Alert Report:** List of the most common alerts.
 - **Anti-Malware Report:** List of the top 25 infected computers.
 - **Attack Report:** Summary table with analysis activity, divided by mode. See [About attack reports](#).
 - **AWS Metered Billing Report:** Summary table of AWS Metered Billing consumption in hours per day by instance size.
 - **Azure Metered Billing Report:** Summary table of Azure Metered Billing consumption in hours per day by instance size.
 - **Computer Report:** Summary of each computer listed on the **Computer** tab.
 - **DPI Rule Recommendation Report:** Intrusion prevention rule recommendations. This report can be run for only one security policy or computer at a time.
 - **Firewall Report:** Record of firewall rule and stateful configuration activity.
 - **Forensic Computer Audit Report:** Configuration of an agent on a computer
 - **Integrity Monitoring Baseline Report:** Baseline of the computers at a particular time, showing Type, Key, and Fingerprinted Date.
 - **Integrity Monitoring Detailed Change Report:** Details about the changes detected

- **Integrity Monitoring Report:** Summary of the changes detected.
 - **Intrusion Prevention Report:** Record of intrusion prevention rule activity.
 - **Log Inspection Detailed Report:** Details of log data that has been collected.
 - **Log Inspection Report:** Summary of log data that has been collected.
 - **Recommendation Report:** Record of recommendation scan activity.
 - **Security Module Usage Cumulative Report:** Current computer usage of protection modules, including a cumulative total and the total in blocks of 100.
 - **Security Module Usage Report:** Current computer usage of protection modules.
 - **Summary Report:** Consolidated summary of Deep Security activity.
 - **Suspicious Application Activity Report:** Information about suspected malicious activity.
 - **System Event Report:** Record of system (non-security) activity.
 - **System Report:** Overview of computers, contacts, and users.
 - **Tenant Report:** Overview of tenants.
 - **User and Contact Report:** Content and activity detail for users and contacts.
 - **Web Reputation Report:** List of computers with the most web reputation events.
3. Select the **Format** for the report, either PDF or RTF. Note that the Security Module Usage Report and Security Module Usage Cumulative Report are exceptions and are always output as CSV files.
 4. You can also add an optional **Classification** to PDF or RTF reports: BLANK, TOP SECRET, SECRET, CONFIDENTIAL, FOR OFFICIAL USE ONLY, LAW ENFORCEMENT SENSITIVE (LES), LIMITED DISTRIBUTION, UNCLASSIFIED, INTERNAL USE ONLY, CUSTOM.
If you specify CUSTOM, the **Name** field is displayed, allowing you to enter a custom string. For example, "Alert report classification".
 5. You can use the **Tag Filter** area to filter the report data using event tags (if you have selected a report that contains event data). Select **All** for all events, **Untagged** for only untagged events, or select **Tag(s)** and specify one or more tags to include only those events with your selected tags.
If you apply multiple contradicting tags, the tags will counteract each other, rather than combine. For example, if you select User Signed In and User Signed Out, there will be no system events.
 6. You can use the **Time Filter** area to set a time filter for any period for which records exist. This is useful for security audits. The following are time filter options:

- **Last 24 Hours:** Includes events from the past 24 hours, starting and ending at the top of the hour. For example, if you generate a report on December 5th at 10:14am, you will get a report for events that occurred between December 4th at 10:00am and December 5th at 10:00am.
- **Last 7 Days:** Includes events from the past week. Weeks start and end at midnight (00:00). For example, if you generate a report on December 5th at 10:14am, you will get a report for events that occurred between November 28th at 0:00am and December 5th at 0:00am.
- **Previous Month:** Includes events from the last full calendar month, starting and ending at midnight (00:00). For example, if you select this option on November 15, you will receive a report for events that occurred between midnight October 1 to midnight November 1.
- **Custom Range:** Enables you to specify your own date and time range for the report. In the report, the start time may be changed to midnight if the start date is more than two days ago.

Note that reports use data stored in counters. Counters are data aggregated periodically from Events. Counter data is aggregated on an hourly basis for the most recent three days. Data from the current hour is not included in reports. Data older than three days is stored in counters that are aggregated on a daily basis. For this reason, the time period covered by reports for the last three days can be specified at an hourly level of granularity, but beyond three days, the time period can only be specified on a daily level of granularity.

7. In the **Computer Filter** area, select the computers whose data will be included in the report:

- **All Computers:** Every computer in Deep Security Manager.
- **My Computers:** If the signed in user has restricted access to computers based on their user role's rights settings, these are the computers to which the signed-in user has view access.
- **In Group:** The computers in a Deep Security group.
- **Using Policy:** The computers using a specific protection Policy.
- **Computer:** A single computer.

To generate a report on specific computers from multiple computer groups, create a user who has viewing rights only to the computers in question and then either create a scheduled task to regularly generate an All Computers report for that user or sign in as that user and run an All Computers report. The report includes only the computers to which that user has viewing rights.

8. In the **Encryption** area, you can protect the report with the password of the currently signed in user or with a new password for this report only:
 - **Disable Report Password:** Report is not password protected.
 - **Use Current User's Report Password:** Use the current user's PDF report password. To view or modify the user's PDF report password, go to **Administration > User Management > Users > Properties > Settings > Reports**.
 - **Use Custom Report Password:** Create a one-time-only password for this report. The password does not have any complexity requirements.

Set up a scheduled report

Scheduled reports are scheduled tasks that periodically generate and distribute reports to any number of users and contacts.

To set up a scheduled report, follow these steps:

1. On the **Events & Reports** tab, in the left pane, click **Generate Reports > Scheduled Reports**.
2. Click **New**. The **New Scheduled Task** wizard opens. Most of the options are identical to those for single reports, with the exception of **Time Filter**:

- **Last [N] Hour(s):** When [N] is less than 60, the start and end times will be at the top of the specified hour. When [N] is more than 60, hourly data is not available for the beginning of the time range, so the start time in the report will be changed to midnight (00:00) of the start day.
- **Last [N] Day(s):** Includes data from midnight [N] days ago to midnight of the current day.
- **Last [N] Week(s):** Includes events from the last [N] weeks, starting and ending at midnight (00:00).
- **Last [N] Month(s):** Includes events from the last [N] full calendar month, starting and ending at midnight (00:00). For example, if you select "Last 1 Month(s)" on November 15,

you will receive a report for events that occurred between midnight October 1 to midnight November 1.

Reports use data stored in counters. Counters are data aggregated periodically from events. Counter data is aggregated on an hourly basis for the most recent three days. Data from the current hour is not included in reports. Data older than three days is stored in counters that are aggregated on a daily basis. For this reason, the time period covered by reports for the last three days can be specified at an hourly level of granularity, but beyond three days, the time period can only be specified on a daily level of granularity.

For more information on scheduled tasks, see the ["Schedule Deep Security to perform tasks" on page 1766](#).

Lists of events and alerts

Predefined alerts

Alert	Default Severity	Dismissible	Description
A computer reboot is required to enable Deep Security Agent protection	Critical	Yes	The agent software upgrade was successful, but a computer reboot is required to disable Windows Defender and enable Deep Security Agent protection.
A Deep Security Relay cannot download security components	Critical	No	A Deep Security Relay can't successfully download security components. This might be due to network connectivity issues or misconfigurations in Deep Security Manager under Administration > System Settings > Updates . Check your network configurations (for example, the proxy settings of the relay group) and System Settings , and then manually initiate an update on the relay using the Download Security Update option on the Administration > Updates > Software page.
Abnormal Restart Detected	Warning	Yes	An abnormal restart has been detected on the computer. This condition may be caused by a variety of conditions. If the agent/appliance is suspected as the root cause then the diagnostics package (located in the Support section of the Computer Details dialog) should be invoked.

Alert	Default Severity	Dismissible	Description
			This alert indicates that the Deep Security Agent service was restarted abnormally. You can safely dismiss this alert, or, if the alert reoccurs, create a diagnostics package and open a case with Technical Support.
Activation Failed	Critical	No	This may indicate a problem with the agent/appliance, but it also can occur if agent self-protection is enabled. On the Deep Security Manager, go to Computer editor ¹ > Settings > General . In Agent Self Protection , and then either deselect Prevent local end-users from uninstalling, stopping, or otherwise modifying the Agent or enter a password for local override.
Agent configuration package too large	Warning	Yes	This is usually caused by too many firewall and intrusion prevention rules being assigned. Run a recommendation scan on the computer to determine if any rules can be safely unassigned.
Agent Heartbeat Public Server Certificate Expired	Critical	No	The public server certificate used for TLS on the agent heartbeat port has expired. New agents may not be able to activate until the certificate is updated.
Agent Heartbeat Public Server Certificate Expires Soon	Warning	No	The public server certificate used for TLS on the agent heartbeat port will expire soon. Renew soon to prevent any disruption to agent communication.
Agent Installation Failed	Critical	Yes	<p>The agent failed to install successfully on one or more computers. Those computers are currently unprotected. You must reboot the computers which will automatically restart the agent install program.</p> <p>This may indicate a problem with the agent/appliance, but it also can occur if agent self-protection is enabled. On the Deep</p>

¹To open the Computer editor, go to the Computers page and double-click the computer that you want to edit (or select the computer and click Details).

Alert	Default Severity	Dismissible	Description
			Security Manager, go to Computer editor ¹ > Settings > General . In Agent Self Protection , and then either deselect Prevent local end-users from uninstalling, stopping, or otherwise modifying the Agent or enter a password for local override.
Agent Upgrade Recommended (Incompatible with Appliance)	Warning	No	Deep Security Manager has detected a computer with a version of the agent that is not compatible with the appliance. The appliance will always filter network traffic in this configuration resulting in redundant protection. (Deprecated in 9.5)
Agent/Appliance Upgrade Recommended	Warning	No	The Deep Security Manager has detected an older agent/appliance version on the computer that does not support all available features. An upgrade of the agent/appliance software is recommended. (Deprecated in 9.5)
Agent/Appliance Upgrade Recommended (Incompatible Security Update(s))	Warning	No	Deep Security Manager has detected a computer with a version of the agent/appliance that is not compatible with one or more security updates assigned to it. An upgrade of the agent/appliance software is recommended.
Agent/Appliance Upgrade Recommended (New Version Available)	Warning	No	Deep Security Manager has detected one or more computers with a version of the agent/appliance that is older than the latest version imported into the manager. An upgrade of the agent/appliance software is recommended.
Agent/Appliance Upgrade Required	Warning	No	Deep Security Manager has detected a computer with a version of the agent/appliance that is not compatible with this version of the manager. An upgrade of the agent/appliance software is required.
An update to the Rules is available	Warning	No	Updated rules have been downloaded but not applied to your policies. To apply the rules, go to Administration > Updates > Security and in the Rule Updates column, click Apply Rules to Policies .
Anti-Malware Alert	Warning	Yes	A malware scan configuration that is configured for alerting has raised an event on one or more computers.

¹To open the Computer editor, go to the Computers page and double-click the computer that you want to edit (or select the computer and click Details).

Alert	Default Severity	Dismissible	Description
Anti-Malware Component Failure	Critical	Yes	An anti-malware component failed on one or more computers. See the event descriptions on the individual computers for specific details.
Anti-Malware Component Update Failed	Warning	No	One or more agent or relay failed to update anti-malware components. See the affected computers for more information.
Anti-Malware Engine Offline	Critical	No	The agent or appliance has reported that the anti-malware engine is not responding. Please check the system events for the computer to determine the cause of the failure.
Anti-malware module maximum disk space used to store identified files exceeded	Warning	Yes	The Anti-Malware module was unable to analyze or quarantine a file because the maximum disk space used to store identified files was reached. To change the maximum disk space for identified files setting, open the computer or policy editor and go to the Anti-malware > Advanced tab.
Anti-Malware protection is absent or out of date	Warning	No	The agent on this computer has not received its initial anti-malware protection package, or its anti-malware protection is out of date. Make sure a relay is available and that the agent has been properly configured to communicate with it. To configure relays and other update options, go to Administration > System Settings > Updates.
API Key Locked Out	Warning	No	API Keys can be locked out manually, or by repeated failed validation attempts.
Application Control Engine Offline	Critical	No	The agent has reported that the Application Control engine failed to initialize. Please check the system events for the computer to determine the cause of the failure.
Application Control Ruleset is incompatible with agent version	Critical	No	An application control ruleset could not be assigned to one or more computers because the ruleset is not supported by the installed version of the agent. Typically, the problem is that a hash-based ruleset (which is compatible only with Deep Security Agent 11.0 or newer) has been assigned to an older Deep Security Agent. Deep Security Agent 10.x supports only file-based rulesets. (For details, see "Differences in how Deep Security Agent 10 and 11 compare files" on page 1075.) To fix this issue, upgrade the Deep Security Agent to version 11.0 or newer. Alternatively, if you are using local rulesets, reset application control for the agent. Or if you are using a shared

Alert	Default Severity	Dismissible	Description
			ruleset, use a shared ruleset that was created with Deep Security 10.x until all agents using the shared ruleset are upgraded to Deep Security Agent 11.0 or newer.
Application Type Misconfiguration	Warning	No	Misconfiguration of application types may prevent proper security coverage.
Application Type Recommendation	Warning	Yes	Deep Security Manager has determined that a computer should be assigned an application type. This could be because an agent was installed on a new computer and vulnerable applications were detected, or because a new vulnerability has been discovered in an installed application that was previously thought to be safe. To assign the application type to the computer, open the 'Computer Details' dialog box, click on 'Intrusion Prevention Rules', and assign the application type.
Azure Account Not Authorized to Read Resources Information	Critical	No	Azure Cloud Account can't retrieve resources information from Azure API because the Azure Application is not authorized to read resources. Please verify that the Reader role has been assigned to the application.
Azure Account Password Invalid	Critical	No	Azure Cloud Account can't retrieve resources information from Azure API because the Azure Application password is invalid.
Azure Account Secret Expired	Critical	No	Azure Cloud Account can't retrieve resources information from Azure API because the Azure Application secret key has expired.
Microsoft Entra ID Application Not Found	Critical	No	Azure Cloud Account can't retrieve resources information from Azure API because the Azure Application is not found. The application possibly has been removed from Microsoft Entra ID.
Microsoft Entra ID Application Certificate expired	Critical	No	The Microsoft Entra ID application cannot sync the cloud data because the application certificate has expired. Renew the Azure Application certificate.
Microsoft Entra ID Application Certificate expires soon	Warning	No	The Microsoft Entra ID application certificate will expire soon. Renew the Azure Application certificate.
Microsoft Entra ID Application Need Renew	Critical	No	The Microsoft Entra ID application can not sync the cloud data now. Maybe the application password is expired or the application is deleted. Please renew the application via Computers > Properties (right click on the

Alert	Default Severity	Dismissible	Description
			target group) > Renew Application Now.
Azure Key Pair Expired	Critical	No	The key pair for Azure service(s) has expired. You can remove this alert by updating your key pair on the Azure service's property page.
Azure Key Pair Expires Soon	Warning	No	The key pair for Azure service(s) will expire soon. You can remove this alert by updating your key pair on the Azure service's property page.
Azure Subscription Not Found	Critical	No	Azure Cloud Account can't retrieve resources information from Azure API because the Azure Subscription cannot be found.
Census, Good File Reputation, and Predictive Machine Learning Service Disconnected	Warning	Yes	Disconnected from Census, Good File Reputation, and Predictive Machine Learning Service. Please see the event details below for possible solutions. Refer to " Warning: Census, Good File Reputation, and Predictive Machine Learning Service Disconnected " on page 1400 for troubleshooting tips.
Certified Safe Software Service Offline	Warning	No	A Deep Security Manager node cannot connect to the Trend Micro Certified Safe Software Service to perform file signature comparisons for the integrity monitoring module. A locally cached database will be used until connectivity is restored. Make sure the manager node has internet connectivity and that proxy settings (if any) are correct.
Clock Change Detected	Warning	Yes	A clock change has been detected on the computer. Unexpected clock changes may indicate a problem on the computer and should be investigated before the alert is dismissed.
Cloud Computer Not Managed as Part of Cloud Account	Warning	Yes	An agent was activated on one or more computers belonging to a cloud account that is not synchronized with Deep Security. Click the link in the 'Action' field above to add the cloud account to Deep Security. The computer(s) will be moved into the account, and may be billed at a lower hourly rate.
Communications Problem Detected	Warning	Yes	A communications problem has been detected on the computer. Communications problems indicate that the computer cannot initiate

Alert	Default Severity	Dismissible	Description
			communication with the Deep Security Manager(s) because of network configuration or load reasons. Please check the system events in addition to verifying communications can be established to the Deep Security Manager(s) from the computer. The cause of the issue should be investigated before the alert is dismissed.
Computer Not Receiving Updates	Warning	No	These computer(s) have stopped receiving updates. Manual intervention may be required.
Computer Reboot Required	Critical	Yes	The agent software upgrade was successful, but the computer must be rebooted for the install to be completed. The computer(s) should be manually updated before the alert is dismissed.
Computer Reboot Required for Activity Monitoring	Critical	No	The Activity Monitoring on Agent has reported that the computer needs to be rebooted. Please check the system events for the computer to determine the reason for the reboot.
Computer Reboot Required for Anti-Malware Protection	Critical	No	The anti-malware protection on the agent has reported that the computer needs to be rebooted. Please check the system events for the computer to determine the reason for the reboot.
Computer Reboot Required for Application Control Protection	Critical	No	The Application Control protection on Agent has reported that the computer needs to be rebooted. Please check the system events for the computer to determine the reason for the reboot.
Computer Reboot Required for Integrity Monitoring Protection	Critical	No	The Integrity Monitoring protection on Agent has reported that the computer needs to be rebooted. Please check the system events for the computer to determine the reason for the reboot.
Configuration Required	Warning	No	One or more computers are using a policy that defines multiple interface types where not all interfaces have been mapped.
Connection to Filter Driver Failure	Critical	No	An appliance has reported a failure connecting to the filter driver. This may indicate a configuration issue with the filter driver running on the ESXi or with the appliance. The appliance must be able to connect to the filter driver in order to protect guests. The cause of the issue should be investigated and resolved.
CPU Critical Threshold Exceeded	Critical	No	The CPU critical threshold has been exceeded.

Alert	Default Severity	Dismissible	Description
CPU Warning Threshold Exceeded	Warning	No	The CPU warning threshold has been exceeded.
Critical database error while creating new table partitions during maintenance job	Critical	No	<p>A critical error occurred during routine database maintenance. During maintenance, new partitions are added to partitioned tables to accommodate new data. During the most recent maintenance job, errors occurred, meaning that some tables are missing future partitions. New data that would ordinarily be written to those partitions may be lost.</p> <p>Please contact your support provider immediately for assistance in resolving this issue. (To facilitate the process, try to have server logs ready, which can be found at the root of DSM directory)</p>
Duplicate Computer Detected	Warning	Yes	A duplicate computer has been activated or imported. Please remove the duplicate computer and reactivate the original computer if necessary.
Duplicate Unique Identifiers Detected	Warning	No	Duplicate UUIDs have been detected. Please remove the duplicate UUID.
Empty Relay Group Assigned	Critical	No	These computers have been assigned an empty relay group. Assign a different relay group to the computers or add relays to the empty relay group(s).
Events Suppressed	Warning	Yes	The agent/appliance encountered an unexpectedly high volume of events. As a result, one or more events were not recorded (suppressed) to prevent a potential denial of service. Check the firewall events to determine the cause of the suppression.
Events Truncated	Warning	Yes	Some events were lost because the data file grew too large for the agent/appliance to store. This may have been caused by an unexpected increase in the number of events being generated, or the inability of the agent/appliance to send the data to the Deep Security Manager. For more information, see the properties of the "Events Truncated" system event on the computer.
Execution of Software Blocked	Warning	Yes	Execution of software was blocked on one or more computers. See the Application Control

Alert	Default Severity	Dismissible	Description
			Events on the following computers for more information.
Failed to Send SNS Message	Critical	No	The Deep Security Manager was unable to forward messages to Amazon SNS
Failed to Send Syslog Message	Warning	No	The Deep Security Manager was unable to forward messages to one or more Syslog Servers.
Files could not be scanned for malware	Warning	No	Files could not be scanned for malware because the file path exceeded the maximum file path length limit or the directory depth exceeded the maximum directory depth limit. Please check the system events for the computer to determine the reason.
Firewall Engine Offline	Critical	No	The agent/appliance has reported that the firewall engine is offline. Please check the status of the engine on the agent/appliance.
Firewall Rule Alert	Warning	Yes	A firewall rule that is selected for alerting has been encountered on one or more computers.
Firewall Rule Recommendation	Warning	Yes	Deep Security Manager has determined that a computer on your network should be assigned a firewall rule. This could be because an agent was installed on a new computer and vulnerable applications were detected, or because a new vulnerability has been discovered in an installed application that was previously thought to be safe. To assign the firewall rule to the computer, open the 'Computer Details' dialog box, click on the 'Firewall Rules' node, and assign the firewall rule.
Heartbeat Server Failed	Warning	No	The heartbeat server failed to start properly. This may be due to a port number conflict. Agents/appliances will not be able to contact the manager until this problem is resolved. To resolve this problem ensure that another service is not using the port number reserved for use by the heartbeat server and "Restart the Deep Security Manager" on page 1694 service. If you do not wish to use the heartbeat you can turn this alert off in the Alert Configuration section.
Incompatible Agent/Appliance Version	Error	No	Deep Security Manager has detected a more recent agent/appliance version on the computer that is not compatible with this version of the manager. An upgrade of the manager software is recommended.

Alert	Default Severity	Dismissible	Description
Insufficient Disk Space	Warning	Yes	The agent/appliance has reported that it was forced to delete an old log file to free up disk space for a new log file. Please immediately free up disk space to prevent loss of intrusion prevention, firewall and agent/appliance events. See " Warning: Insufficient disk space " on page 1402.
Integrity Monitoring Engine Offline	Critical	No	The agent/appliance has reported that the integrity monitoring engine is not responding. Please check the system events for the computer to determine the cause of the failure.
Integrity Monitoring information collection has been delayed	Warning	No	The rate at which integrity monitoring information is collected has been temporarily delayed due to an increased amount of integrity monitoring data. During this time the baseline and integrity event views may not be current for some computers. This alert will be dismissed automatically once integrity monitoring data is no longer being delayed.
Integrity Monitoring Rule Alert	Warning	Yes	An integrity monitoring rule that is selected for alerting has been encountered on one or more computers.
Integrity Monitoring Rule Compilation Error	Critical	No	An error was encountered compiling an integrity monitoring rule on a computer. This may result in the integrity monitoring rule not operating as expected.
Integrity Monitoring Rule Recommendation	Warning	Yes	Deep Security Manager has determined that a computer on your network should be assigned an integrity monitoring rule. To assign the integrity monitoring rule to the computer, open the 'Computer Details' dialog box, click on the 'Integrity Monitoring > Integrity Monitoring Rules' node, and assign the integrity monitoring rule.
Integrity Monitoring Rule Requires Configuration	Warning	No	An integrity monitoring rule that requires configuration before use has been assigned to one or more computers. This rule will not be sent to the computer(s). Open the integrity monitoring rule properties and select the Configuration tab for more information.
Integrity Monitoring Trusted Platform Module Not Enabled	Warning	Yes	Trusted platform module not enabled. Please ensure the hardware is installed and the BIOS setting is correct.
Integrity Monitoring Trusted Platform Module Register Value Changed	Warning	Yes	Trusted platform module register value changed. If you have not modified the ESXi hypervisor configuration this may represent an

Alert	Default Severity	Dismissible	Description
			attack.
Intrusion Prevention Engine Offline	Critical	No	The agent/appliance has reported that the intrusion prevention engine is offline. Please check the status of the engine on the agent/appliance.
Intrusion Prevention Rule Alert	Warning	Yes	An intrusion prevention rule that is selected for alerting has been encountered on one or more computers.
Intrusion Prevention Rule Compilation Failed	Critical	Yes	This is usually caused by a misconfigured IPS Rule. The Rule name can be found in the Event's Properties window. To resolve this issue, identify the Rule and unassign it or contact Trend Micro Support for assistance.
Intrusion Prevention Rule Requires Configuration	Warning	No	An intrusion prevention rule that requires configuration before use has been assigned to one or more computers. This rule will not be sent to the computer(s). Open the intrusion prevention rule properties and select the Configuration tab for more information.
Invalid System Settings Detected	Critical	No	The Deep Security Manager detected invalid values for one or more system settings.
Legacy Agent Software Detected	Warning	Yes	We have detected software whose version is less than 9.5, and is no longer supported. Please import the latest software to replace it. For details, see "Get Deep Security Agent software" on page 497 .
Log Inspection Engine Offline	Critical	No	The agent/appliance has reported that the log inspection engine has failed to initialize. Please check the system events for the computer to determine the cause of the failure.
Log Inspection Rule Alert	Warning	Yes	A log inspection rule that is selected for alerting has been encountered on one or more computers.
Log Inspection Rule Recommendation	Warning	Yes	Deep Security Manager has determined that a computer on your network should be assigned a log inspection rule. To assign the log inspection rule to the computer, open the 'Computer Details' dialog box, click on the 'Log Inspection > Log Inspection Rules' node, and assign the log inspection rule.
Log Inspection Rule Requires Configuration	Warning	No	A log inspection rule that requires configuration before use has been assigned to one or more computers. This rule will not be sent to the computer(s). Open the Log Inspection Rule

Alert	Default Severity	Dismissible	Description
			properties and select the Configuration tab for more information.
Low Disk Space	Warning	No	A Deep Security Manager Node has less than 10% remaining disk space. Please free space by deleting old or unnecessary files, or add more storage capacity.
Maintenance Mode On	Warning	No	Maintenance mode is currently active for application control on one or more computers. While this mode is active, application control continues to enforce block rules (if you selected Block unrecognized software until it is explicitly allowed), but will allow software updates, and automatically add them to the inventory part of the ruleset. When the software update is finished for each computer, disable maintenance mode so that unauthorized software is not accidentally added to the ruleset.
Manager Offline	Warning	No	A Deep Security Manager node is offline. It is possible the computer has a hardware or software problem, or has simply lost network connectivity. Please check the status of the manager's computer.
Manager Time Out of Sync	Critical	No	The clock on each manager node must be synchronized with the clock on the database. If the clocks are too far out of sync (more than 30 seconds) the manager node will not perform its tasks correctly. Synchronize the clock on your manager node with the clock on the database.
Memory Critical Threshold Exceeded	Critical	No	The memory critical threshold has been exceeded.
Memory Warning Threshold Exceeded	Warning	No	The memory warning threshold has been exceeded.
Move Failed	Warning	Yes	<p>Computer was not moved to Trend Cloud One - Endpoint & Workload Security due to a connectivity issue.</p> <p>Before trying the move again:</p> <ul style="list-style-type: none"> • Check that all parameters specified for the move are correct, including the tenant information, activation token, public CA certificate, and proxy settings.

Alert	Default Severity	Dismissible	Description
			<ul style="list-style-type: none"> • Check that there are no networking/firewall settings preventing the agent from reaching Trend Cloud One - Endpoint & Workload Security. • Use the CLI to create an agent diagnostic package, which will include a ds_agent.log file containing information about the failed move. For instructions on creating diagnostic packages, see Create a diagnostic package and logs.
Move Failed: No response	Warning	Yes	<p>Computer was not moved to Trend Cloud One - Endpoint & Workload Security because the move request timed out.</p> <p>If using manager-initiated activation, there was no response from the agent after the manager initiated the command.</p> <p>If using agent-initiated activation, there was no heartbeat from the agent.</p> <p>Check the agent status and try the move again.</p>
Move Failed: Failed to activate	Warning	Yes	<p>The move to Trend Cloud One - Endpoint & Workload Security failed due to an activation issue and was rolled back.</p> <p>Before trying the move again:</p> <ul style="list-style-type: none"> • Check that all parameters specified for the move are correct, including the tenant information, activation token, public CA certificate, and proxy settings. • Use the CLI to create an agent diagnostic package, which will include dsa_move.log and dsa_control.log files containing information about the failed move. For instructions on creating

Alert	Default Severity	Dismissible	Description
			diagnostic packages, see Create a diagnostic package and logs .
Move Failed: Unmanaged	Critical	Yes	<p>The move to Trend Cloud One - Endpoint & Workload Security failed due to an activation issue and the move could not be rolled back. The computer is in an unmanaged state.</p> <p>To troubleshoot this issue:</p> <ul style="list-style-type: none"> • Look into the dsa_move.log file, which contains information about the failed move. • Manually restore the agent or reactivate the agent. See the troubleshooting section for more details. <p>Before trying the move again:</p> <ul style="list-style-type: none"> • Check that the Workload Security Link is up-to-date. • Check that all parameters specified for the move are correct, including the tenant information, activation token, public CA certificate, and proxy settings.
Network Engine Mode Incompatibility	Warning	No	Setting Network Engine Mode to Tap is only available on agent versions 5.2 or later. Review and update the agent's configuration or upgrade the agent to resolve the incompatibility.
New Pattern Update is Downloaded and Available	Warning	No	New patterns are available as part of a security update. The patterns have been downloaded to Deep Security but have not yet been applied to your computers. To apply the update to your computers, go to the Administration > Updates > Security page.
New Rule Update is Downloaded and Available	Warning	No	New rules are available as part of a security update. The rules have been downloaded to Deep Security but have not yet been applied to policies and sent to your computers. To apply the update and send the updated policies to

Alert	Default Severity	Dismissible	Description
			your computers, go to the Administration > Updates > Security page.
Newer Version of Deep Security Manager is Available	Warning	No	A new version of the Deep Security Manager is available. Download the latest version from the Trend Micro Download Center at http://downloadcenter.trendmicro.com/
Newer Versions of Software Available	Warning	No	New software is available. Software can be downloaded from the Download Center.
Number of Computers exceeds database limit	Warning	No	The number of activated computers has exceeded the recommended limit for an embedded database. Performance will degrade rapidly if more computers are added and it is strongly suggested that another database option (Oracle or SQL Server) be considered at this point. Please contact Trend Micro for more information on upgrading your database.
Protection Module Licensing Expired	Warning	Yes	The protection module license has expired.
Protection Module Licensing Expires Soon	Warning	No	The protection module licensing will expire soon. You can remove this alert by changing your license on the Administration > Licenses page.
Recommendation	Warning	Yes	Deep Security Manager has determined that the security configuration of one of your computers should be updated. To see what changes are recommended, open the Computer editor ¹ and look through the module pages for warnings of unresolved recommendations. In the Assigned Rules area, click Assign/Unassign to display the list of available rules and then filter them using the "Show Recommended for Assignment" viewing filter option. (Select "Show Recommended for Unassignment" to display rules that can safely be unassigned.)
Reconnaissance Detected: Computer OS Fingerprint Probe	Warning	Yes	The agent or appliance detected an attempt to identify the computer operating system via a "fingerprint" probe. Such activity is often a precursor to an attack that targets specific vulnerabilities. Check the computer's events to see the details of the probe and see " Warning:

¹To open the Computer editor, go to the Computers page and double-click the computer that you want to edit (or select the computer and click Details).

Alert	Default Severity	Dismissible	Description
			"Reconnaissance Detected" on page 1402.
Reconnaissance Detected: Network or Port Scan	Warning	Yes	The agent or appliance detected network activity typical of a network or port scan. Such activity is often a precursor to an attack that targets specific vulnerabilities. Check the computer's events to see the details of the probe and see "Warning: Reconnaissance Detected" on page 1402.
Reconnaissance Detected: TCP Null Scan	Warning	Yes	The agent or appliance detected a TCP "Null" scan. Such activity is often a precursor to an attack that targets specific vulnerabilities. Check the computer's events to see the details of the probe and see "Warning: Reconnaissance Detected" on page 1402.
Reconnaissance Detected: TCP SYNFIN Scan	Warning	Yes	The agent or appliance detected a TCP "SYNFIN" scan. Such activity is often a precursor to an attack that targets specific vulnerabilities. Check the computer's events to see the details of the probe and see "Warning: Reconnaissance Detected" on page 1402.
Reconnaissance Detected: TCP Xmas Scan	Warning	Yes	The agent or appliance detected a TCP "Xmas" scan. Such activity is often a precursor to an attack that targets specific vulnerabilities. Check the computer's events to see the details of the probe and see "Warning: Reconnaissance Detected" on page 1402.
Relay Upgrade Required For Agent Integrity Check	Warning	No	To enable Agent Integrity Check, please upgrade relay.
SAML Identity Provider Certificate expired	Critical	No	One or more SAML Identity Provider Certificate (s) expired.
SAML Identity Provider Certificate expires soon	Warning	No	One or more SAML Identity Provider Certificate (s) will expire soon.
SAML Service Certificate expired	Critical	No	SAML Service Provider Certificate expired.
SAML Service Certificate expires soon	Warning	No	SAML Service Provider Certificate expires soon.
SAP Virus Scan Adapter is not installed	Critical	No	The agent has reported that the SAP Virus Scan Adapter is not installed. Check the system events for the computer to determine the cause of the failure.
SAP Virus Scan Adapter is not up to date	Critical	No	The agent has reported that the SAP Virus Scan Adapter is not up to date. Check the system events for the computer to determine the cause of the failure.
Scheduled Malware Scan Missed	Warning	No	Scheduled malware scan tasks were initiated

Alert	Default Severity	Dismissible	Description
			on computers that already had pending scan tasks. This may indicate a scanning frequency that is too high. Consider lowering the scanning frequency, or selecting fewer computers to scan during each scheduled scan job.
Send Policy Failed	Critical	No	Inability to send policy may indicate a problem with the agent/appliance. Please check the affected computers.
Smart Protection Server Connection Failed	Warning	Yes	Failed to connect to a Smart Protection Server. This could be due to a configuration issue, or due to network connectivity.
Software Changes Detected	Warning	No	During ongoing file system monitoring, application control detected that new software had been installed, and it did not match any configured allow or block rule. If your system administrators did not install the software, and no other users have permissions to install software, this could indicate a security compromise. If the software tries to launch, depending on your lockdown configuration at that time, it may or may not be allowed to execute.
Software Package Not Found	Critical	No	An agent software package is required for the proper operation of one or more virtual appliance(s). Please import a Red Hat Enterprise Linux 6 (64 bit) agent software package with the correct version for each appliance. If the required version is not available then please import the latest package and upgrade the appliance to match.
Software Updates Available for Import	Warning	No	New software is available. To import new software to Deep Security, go to Administration > Updates > Software > Download Center.
Unable to communicate	Critical	No	Deep Security Manager has been unable to query the agent/appliance for its status within the configured period. Please check your network configuration and the affected computer's connectivity.
Unable to Upgrade the Agent Software	Warning	Yes	Deep Security Manager was unable to upgrade the agent software on the computer.

Alert	Default Severity	Dismissible	Description
			This may indicate a problem with the agent/appliance, but it also can occur if agent self-protection is enabled. On the Deep Security Manager, go to Computer editor ¹ > Settings > General . In Agent Self Protection , and then either deselect Prevent local end-users from uninstalling, stopping, or otherwise modifying the Agent or enter a password for local override.
Unresolved software change limit reached	Critical	No	Software changes detected on the file system exceeded the maximum amount. Application control will continue to enforce existing rules, but will not record any more changes, and it will stop displaying any of that computer's software changes. You must resolve and prevent excessive software change.
Upgrade of the Deep Security Manager Software Recommended (Incompatible Security Update(s))	Warning	No	Deep Security Manager has detected a computer that is using security updates that are not compatible with the current version of Deep Security Manager. An upgrade of Deep Security Manager software is recommended.
User Locked Out	Warning	No	Users can be locked out manually, by repeated incorrect sign-in attempts, if their password expires, or if they have been imported but not yet unlocked.
User Password Expires Soon	Warning	No	The password expiry setting is enabled and one or more users have passwords that will expire within the next 7 days.
Virtual Appliance is Incompatible With Filter Driver	Warning	No	The appliance is incompatible with the filter driver. Please ensure both are upgraded to their latest versions.
Virtual Machine Interfaces Out of Sync	Warning	No	One or more of the virtual machines monitored by a Deep Security Virtual Appliance has reported that its interfaces are out of sync with the filter driver. This means that the appliance may not be properly monitoring the virtual machine's interfaces. The virtual machine may require manual intervention such as a configuration change, or a restart, to correct the issue.

¹To open the Computer editor, go to the Computers page and double-click the computer that you want to edit (or select the computer and click Details).

Alert	Default Severity	Dismissible	Description
Virtual Machine Moved to Unprotected ESXi Server	Warning	Yes	A virtual machine was moved to an ESXi Server that does not have an activated Deep Security Virtual Appliance.
Virtual Machine Unprotected after move to another ESXi	Warning	Yes	A virtual machine that was appliance-protected has been unprotected during or after it was moved to another ESXi. This may be due to an appliance reboot or power off during the move, or it may indicate a configuration issue. The cause of the issue should be investigated before the alert is dismissed.
VMware Tools Not Installed	Critical	Yes	A protected virtual machine in an NSX environment does not have VMware Tools installed. VMware Tools is required to protect virtual machines in an NSX environment.
Web Reputation Event Alert	Warning	Yes	A web reputation event has been encountered on one or more computers that are selected for alerting.
WorkSpaces Disabled for AWS Account	Warning	Yes	An agent was activated on one or more Amazon WorkSpaces but WorkSpaces are not enabled for your AWS account. To enable WorkSpaces, click 'Edit AWS Account' above, and select the 'Include Amazon WorkSpaces' check box. Your Workspace(s) will be moved into the WorkSpaces folder of the AWS account.

Agent events

ID	Severity	Event	Notes
Special Events			
0	Error	Unknown Agent/Appliance Event	
Driver-Related Events			
1000	Error	Unable To Open Engine	
1001	Error	Engine Command Failed	
1002	Warning	Engine List Objects Error	
1003	Warning	Remove Object Failed	
1004	Error	Driver Upgrade Stalled	
1005	Warning	Upgrading Driver	
1006	Error	Driver Upgrade Requires Reboot	
1007	Warning	Driver Upgrade Succeeded	
1008	Error	Kernel Unsupported	

ID	Severity	Event	Notes
1010	Warning	Trend Micro LightWeight Filter Driver has been disabled	
1011	Info	Trend Micro LightWeight Filter Driver has been restarted	
1012	Info	All Trend Micro LightWeight Filter Drivers have been restarted successfully	
1013	Warning	Trend Micro LightWeight Filter Driver failed to bind on all network interfaces	
Configuration-Related Events			
2000	Info	Policy Sent	
2001	Warning	Invalid Firewall Rule Assignment	
2002	Warning	Invalid Firewall Stateful Configuration	
2003	Error	Save Security Configuration Failed	
2004	Warning	Invalid Interface Assignment	
2005	Warning	Invalid Interface Assignment	
2006	Warning	Invalid Action	
2007	Warning	Invalid Packet Direction	
2008	Warning	Invalid Rule Priority	
2009	Warning	Unrecognized IP Format	
2010	Warning	Invalid Source IP List	
2011	Warning	Invalid Source Port List	
2012	Warning	Invalid Destination IP List	
2013	Warning	Invalid Destination Port List	
2014	Warning	Invalid Schedule	
2015	Warning	Invalid Source MAC List	
2016	Warning	Invalid Destination MAC List	
2017	Warning	Invalid Schedule Length	
2018	Warning	Invalid Schedule String	
2019	Warning	Unrecognized IP Format	
2020	Warning	Object Not Found	
2021	Warning	Object Not Found	
2022	Warning	Invalid Rule Assignment	
2050	Warning	Firewall Rule Not Found	
2075	Warning	Traffic Stream Not Found	
2076	Warning	Intrusion Prevention Rule Not Found	
2077	Warning	Pattern List Not Found	

ID	Severity	Event	Notes
2078	Warning	Traffic Stream Conversion Error	
2080	Warning	Conditional Firewall Rule Not Found	
2081	Warning	Conditional Intrusion Prevention Rule Not Found	
2082	Warning	Empty Intrusion Prevention Rule	
2083	Warning	Intrusion Prevention Rule XML Rule Conversion Error	
2085	Error	Security Configuration Error	
2086	Warning	Unsupported IP Match Type	
2087	Warning	Unsupported MAC Match Type	
2088	Warning	Invalid SSL Credential	
2089	Warning	Missing SSL Credential	
2090	Error	Security Configuration Error	
2091	Error	Security Configuration Error	
Hardware-Related Events			
3000	Warning	Invalid MAC Address	
3001	Warning	Get Event Data Failed	
3002	Warning	Too Many Interfaces	
3003	Error	Unable To Run External Command	
3004	Error	Unable To Read External Command Output	
3005	Error	Operating System Call Error	
3006	Error	Operating System Call Error	
3007	Error	File Error	
3008	Error	Machine-Specific Key Error	
3009	Error	Unexpected Agent/Appliance Shutdown	
3010	Error	Agent/Appliance Database Error	
3300	Warning	Get Event Data Failed	Linux error.
3302	Warning	Get Security Configuration Failed	Linux error.
3303	Error	File Mapping Error	Linux error. File type error.
3600	Error	Get Windows System Directory Failed	
3601	Warning	Read Local Data Error	Windows error.
3602	Warning	Windows Service Error	Windows error.
3603	Error	File Mapping Error	Windows error. File size error.
3700	Warning	Abnormal Restart Detected	Windows error.

ID	Severity	Event	Notes
3701	Info	System Last Boot Time Change	Windows error.
Communications-Related Events			
4000	Warning	Invalid Protocol Header	Content length out of range.
4001	Warning	Invalid Protocol Header	Content length missing.
4002	Info	Command Session Initiated	
4003	Info	Configuration Session Initiated	
4004	Info	Command Received	
4011	Warning	Failure to Contact Manager	
4012	Warning	Heartbeat Failed	
Agent-Related Events			
5000	Info	Agent/Appliance Started	
5001	Error	Thread Exception	
5002	Error	Operation Timed Out	
5003	Info	Agent/Appliance Stopped	
5004	Warning	Clock Changed	
5005	Info	Agent/Appliance Auditing Started	
5006	Info	Agent/Appliance Auditing Stopped	
5007	Info	Appliance Protection Change	
5008	Warning	Filter Driver Connection Failed	
5009	Info	Filter Driver Connection Success	
5010	Warning	Filter Driver Informational Event	
5100	Info	Protection Module Deployment Started	
5101	Info	Protection Module Deployment Succeeded	
5102	Error	Protection Module Deployment Failed	
5103	Info	Protection Module Download Succeeded	
5104	Info	Protection Module Disablement Started	
5105	Info	Protection Module Disablement Succeeded	
5106	Error	Protection Module Disablement Failed	
5107	Info	Agent Self-Protection enabled	

ID	Severity	Event	Notes
5108	Info	Agent Self-Protection disabled	
5109	Error	FIPS verification Error	
5110	Error	Secure Boot Public Key Not Enrolled	This error can occur if the public key required to check the signature on the Trend Micro kernel module is not successfully enrolled on the agent computer. For details, see "Configure Linux Secure Boot for agents" on page 504.
5111	Error	Secure Boot 'On' Not Supported	Deep Security Agent does not support this OS with Secure Boot enabled. For details, see "Configure Linux Secure Boot for agents" on page 504.
5200	Info	File Backup Completed	
5201	Error	Failure to Backup File	
Logging-Related Events			
6000	Info	Log Device Open Error	
6001	Info	Log File Open Error	
6002	Info	Log File Write Error	
6003	Info	Log Directory Creation Error	
6004	Info	Log File Query Error	
6005	Info	Log Directory Open Error	
6006	Info	Log File Delete Error	
6007	Info	Log File Rename Error	
6008	Info	Log Read Error	
6009	Warning	Log File Deleted Due To Insufficient Space	
6010	Warning	Events Were Suppressed	
6011	Warning	Events Truncated	
6012	Error	Insufficient Disk Space	See "Warning: Insufficient disk space" on page 1402.
6013	Warning	Agent configuration package too large	
Attack-, Scan-, and Probe-Related Events			
7000	Warning	Computer OS Fingerprint Probe	
7001	Warning	Network or Port Scan	
7002	Warning	TCP Null Scan	
7003	Warning	TCP SYNFIN Scan	
7004	Warning	TCP Xmas Scan	
Download Security Update Events			

ID	Severity	Event	Notes
9050	Info	Update of Anti-Malware Component on Agent Succeeded	
9051	Error	Update of Anti-Malware Component on Agent Failed	
9100	Info	Security Update Successful	
9101	Error	Security Update Failure	
9102	Error	Security Update Failure	Specific information recorded in error message.
Relay Events			
9103	Info	Relay Web Server Disabled	
9104	Info	Relay Web Server Enabled	
9105	Error	Enable Relay Web Server Failed	
9106	Error	Disable Relay Web Server Failed	
9107	Error	Relay Web Server failed	
9108	Info	Unable to Connect to Update Source	
9109	Error	Component Update Failure	
9110	Error	Anti-Malware license is expired	
9111	Info	Security Update Rollback Success	
9112	Error	Security Update Rollback Failure	
9113	Info	Relay Replicated All Packages	
9114	Error	Relay Failed to Replicate All Packages	
9115	Info	Failed to download from the Relay Web Server	
Integrity Scan Status Events			
9201	Info	Integrity Scan Started	
9203	Info	Integrity Scan Terminated Abnormally	
9204	Info	Integrity Scan Paused	
9205	Info	Integrity Scan Resumed	
9208	Warning	Integrity Scan failed to start	
9209	Warning	Integrity Scan Stalled	
Smart Protection Server Status Events			
9300	Warning	Smart Protection Server Disconnected for Web Reputation	See "Troubleshoot "Smart Protection Server disconnected" errors" on page 1374.
9301	Info	Smart Protection Server Connected for Web	See "Troubleshoot "Smart Protection Server disconnected" errors" on page 1374.

ID	Severity	Event	Notes
		Reputation	
9302	Warning	Census, Good File Reputation, and Predictive Machine Learning Service Disconnected	
9303	Info	Census, Good File Reputation, and Predictive Machine Learning Service Connected	

System events

To view system events, go to **Events & Reports > Events**.

To configure system events, go to the **Administration > System Settings > System Events** tab. On this tab you can set whether to record individual events and whether to [forward them to a SIEM server](#). If you select **Record**, then the event is saved to the database. If you deselect **Record**, then the event won't appear under the **Events & Reports** tab (or anywhere in Deep Security Manager) and it won't be forwarded either.

Depending on whether it's a system configuration change or security incident, each log will appear in either the **System Events** sub-menu, or the sub-menu corresponding to the event's protection module, such as **Anti-Malware Events**.

These events sometimes also appear in the Status column on **Computers**.

ID	Severity	Event	Description or Solution
0	Error	Unknown Error	
100	Info	Deep Security Manager Started	
101	Info	License Changed	
102	Info	Trend Micro Deep Security Customer Account Changed	
103	Warning	Check For Updates Failed	
104	Warning	Automatic Software Download Failed	
105	Warning	Scheduled Rule Update Download and Apply Failed	
106	Info	Scheduled Rule	

ID	Severity	Event	Description or Solution
		Update Downloaded and Applied	
107	Info	Rule Update Downloaded and Applied	
108	Info	Script Executed	
109	Error	Script Execution Failed	
110	Info	System Events Exported	
111	Info	Firewall Events Exported	
112	Info	Intrusion Prevention Events Exported	
113	Warning	Scheduled Rule Update Download Failed	
114	Info	Scheduled Rule Update Downloaded	
115	Info	Rule Update Downloaded	
116	Info	Rule Update Applied	
117	Info	Deep Security Manager Shutdown	
118	Warning	Deep Security Manager Offline	
119	Info	Deep Security Manager Back Online	
120	Error	Heartbeat Server Failed	The server within Deep Security Manager that listens for incoming agent heartbeats did not start. Check that the manager's incoming heartbeat port number is not in use by another application on the server. Once the port is free, the manager's heartbeat server should bind to it, and this error should be fixed.
120	Error	Scheduler Failed	
122	Error	Manager Message Thread Failed	An internal thread has failed. There is no resolution for this error. If it persists, please contact customer support.
123	Info	Deep Security Manager Forced Shutdown	

ID	Severity	Event	Description or Solution
124	Info	Rule Update Deleted	
130	Info	Credentials Generated	
131	Warning	Credential Generation Failed	
140	Info	Discover Computers	
141	Warning	Discover Computers Failed	
142	Info	Discover Computers Requested	
143	Info	Discover Computers Canceled	
150	Info	System Settings Saved	
151	Info	Software Added	
152	Info	Software Deleted	
153	Info	Software Updated	
154	Info	Software Exported	
155	Info	Software Platforms Changed	
156	Error	Agent Installer Digital Signature Verification Failed	<p>'<agent>.zip' has been deleted because the digital signature verification failed. The failure indicates that the file may have been tampered with. Details:</p> <p><detailed_message></p> <p>Please contact Trend Micro support for more help.</p> <p>See "Check digital signatures on software packages" on page 427 for details.</p>
160	Info	Authentication Failed	
161	Info	Rule Update Exported	
162	Info	Log Inspection Events Exported	
163	Info	Anti-Malware Event Exported	
164	Info	Security Update Successful	
165	Error	Security Update	

ID	Severity	Event	Description or Solution
		Failed	
166	Info	Check for New Software Success	
167	Error	Check for New Software Failed	
168	Info	Manual Security Update Successful	
169	Error	Manual Security Update Failed	
170	Error	Manager Available Disk Space Too Low	The manager does not have enough free disk space to function and will shut down. Either expand the disk space or delete unused files to free some disk space, then " Restart the Deep Security Manager " on page 1694.
171	Info	Anti-Malware Spyware Item Exported	
172	Info	Web Reputation Events Exported	
173	Info	Anti-Malware Identified Files List Exported	
174	Info	Anti-Malware Unauthorized Change Targeted Item Exported	
175	Info	Creating Heap Dump	
176	Info	Heap Dump Created	
177	Error	Failed to create Heap Dump	
180	Info	Alert Type Updated	
190	Info	Alert Started	
191	Info	Alert Changed	
192	Info	Alert Ended	
197	Info	Alert Emails Sent	
198	Warning	Alert Emails Failed	An alert email could not be sent. Verify that your SMTP settings are correct.
199	Error	Alert Processing Failed	The current alert status could be inaccurate because an alert was not completely processed. If the problem persists, contact your support provider.
247	Warning	Agent Integrity Check Failed	
248	Info	Software Update: Disable Relay	

ID	Severity	Event	Description or Solution
		Requested	
249	Info	Software Update: Enable Relay Requested	
250	Info	Computer Created	
251	Info	Computer Deleted	
252	Info	Computer Updated	
253	Info	Policy Assigned to Computer	
254	Info	Computer Moved	
255	Info	Activation Requested	
256	Info	Send Policy Requested	
257	Info	Locked	
258	Info	Unlocked	
259	Info	Deactivation Requested	
260	Info	Scan for Open Ports	
261	Warning	Scan for Open Ports Failed	
262	Info	Scan for Open Ports Requested	
263	Info	Scan for Open Ports Canceled	
264	Info	Agent Software Upgrade Requested	
265	Info	Agent Software Upgrade Cancelled	
266	Info	Warnings/Errors Cleared	
267	Info	Check Status Requested	
268	Info	Get Events Requested	
269	Info	Computer Added to Cloud Connector	
270	Error	Computer Creation Failed	
271	Info	Agent Software	

ID	Severity	Event	Description or Solution
		Upgrade Timed Out	
272	Info	Appliance Software Upgrade Timed Out	
273	Info	Security Update: Security Update Check and Download Requested	
274	Info	Security Update: Security Update Rollback Requested	
275	Warning	Duplicate Computer	
276	Info	Update: Summary Information	
277	Info	Upgrade on Activation Skipped	The agent was eligible for an automatic upgrade, but the upgrade did not occur. For more information, see "Automatically upgrade agents on activation" on page 1462.
278	Info	Software Update: Reboot to Complete Agent Software Upgrade	
280	Info	Computers Exported	
281	Info	Computers Imported	
286	Info	Computer Log Exported	
287	Info	Relay Group Assigned to Computer	
290	Info	Group Added	
291	Info	Group Removed	
292	Info	Group Updated	
293	Info	Interface Renamed	
294	Info	Computer Bridge Renamed	
295	Info	Interface Deleted	
296	Info	Interface IP Deleted	
297	Info	Recommendation Scan Requested	

ID	Severity	Event	Description or Solution
298	Info	Recommendations Cleared	
299	Info	Asset Value Assigned to Computer	
300	Info	Recommendation Scan Completed	
301	Info	Agent Software Deployment Requested	
302	Info	Agent Software Removal Requested	
303	Info	Computer Renamed	
304	Info	Computer Moved To Datacenter	The virtual machine (VM) was placed in its root data center folder because Deep Security Manager couldn't determine the VM's parent folder due to a permission issue. To have the VM appear in the correct folder in Deep Security Manager, check the permissions of the VM on the vCenter server.
305	Info	Scan for Integrity Requested	
306	Info	Rebuild Baseline Requested	
307	Info	Cancel Update Requested	
308	Info	Integrity Monitoring Rule Compile Issue	
309	Info	Integrity Monitoring Rule Compile Issue Resolved	
310	Info	Directory Added	
311	Info	Directory Removed	
312	Info	Directory Updated	
320	Info	Directory Synchronization	
321	Info	Directory Synchronization Finished	
322	Error	Directory Synchronization Failed	

ID	Severity	Event	Description or Solution
323	Info	Directory Synchronization Requested	
324	Info	Directory Synchronization Cancelled	
325	Info	User Synchronization	Synchronization of the user accounts with Microsoft Active Directory has been started.
326	Info	User Synchronization Finished	Synchronization of the user accounts with Microsoft Active Directory has completed.
327	Error	User Synchronization Failed	
328	Info	User Synchronization Requested	
329	Info	User Synchronization Cancelled	
330	Info	SSL Configuration Created	
331	Info	SSL Configuration Deleted	
332	Info	SSL Configuration Updated	
333	Info	Host Merge Finished	
334	Error	Host Merge Failed	
338	Warning	Directory Synchronization Limit Exceeded	Reached the limit of total group members for Active Directory synchronization. Skipping any remaining members. Consider adjusting the limit in the system setting.
350	Info	Policy Created	
351	Info	Policy Deleted	
352	Info	Policy Updated	
353	Info	Policies Exported	
354	Info	Policies Imported	
355	Info	Scan for Recommendations Canceled	
356	Error	Secure Boot Public Key Not Enrolled	<p>This error can occur if the public key required to check the signature on the Trend Micro kernel module is not successfully enrolled on the agent computer.</p> <p>For details, see "Configure Linux Secure Boot for agents" on</p>

ID	Severity	Event	Description or Solution
			page 504.
357	Error	Secure Boot 'On' Not Supported	Deep Security Agent does not support this OS with Secure Boot enabled. For details, see " Configure Linux Secure Boot for agents " on page 504.
360	Info	VMware vCenter Added	
361	Info	VMware vCenter Removed	
362	Info	VMware vCenter Updated	
363	Info	VMware vCenter Synchronization	
364	Info	VMware vCenter Synchronization Finished	
365	Error	VMware vCenter Synchronization Failed	
366	Info	VMware vCenter Synchronization Requested	
367	Info	VMware vCenter Synchronization Cancelled	
368	Warning	Interfaces Out of Sync	Interfaces reported by the Deep Security Virtual Appliance are different than the interfaces reported by the vCenter. This can typically be resolved by rebooting the VM.
369	Info	Interfaces in Sync	
370	Info	Filter Driver Installed	
371	Info	Filter Driver Removed	The VMware ESXi server has been restored to the state it was in before the filter driver software was installed.
372	Info	Filter Driver Upgraded	
373	Info	Virtual Appliance Deployed	
374	Info	Virtual Appliance Upgraded	
375	Warning	Virtual Appliance Upgrade Failed	
376	Warning	Virtual Machine Moved to Unprotected ESXi	

ID	Severity	Event	Description or Solution
377	Info	Virtual Machine Moved to Protected ESXi	
378	Warning	Virtual Machine unprotected after move to another ESXi	A VM was moved to an ESXi where there is no Deep Security Virtual Appliance.
379	Info	Virtual Machine unprotected after move to another ESXi Resolved	
380	Error	Filter Driver Offline	The filter driver on an ESXi server is offline. Use the VMware vCenter console to troubleshoot problems with the hypervisor and the ESXi.
381	Info	Filter Driver Back Online	
382	Info	Filter Driver Upgrade Requested	
383	Info	Appliance Upgrade Requested	
384	Warning	Prepare ESXi Failed	
385	Warning	Filter Driver Upgrade Failed	
386	Warning	Removal of Filter Driver from ESXi Failed	
387	Error	Connection to Filter Driver Failure	
388	Info	Connection to Filter Driver Success	
389	Error	Multiple Activated Appliances Detected	
390	Info	Multiple Activated Appliances Detected Resolved	
391	Error	Network Settings Out of Sync With vCenter Global Settings	

ID	Severity	Event	Description or Solution
392	Info	Network Settings in Sync With vCenter Global Settings	
393	Error	Anti-Malware Engine Offline	The anti-malware protection module is not functioning. This is probably because the VMware environment does not meet the requirements. See "System requirements" on page 329 .
394	Info	Anti-Malware Engine Back Online	
395	Error	Virtual Appliance is Incompatible With Filter Driver	
396	Info	Virtual Appliance is Incompatible With Filter Driver Resolved	
397	Warning	VMware NSX Callback Authentication Failed	
398	Error	VMware Tools Not Installed	
399	Info	VMware Tools Not Installed Resolved	
410	Info	Firewall Rule Created	
411	Info	Firewall Rule Deleted	
412	Info	Firewall Rule Updated	
413	Info	Firewall Rule Exported	
414	Info	Firewall Rule Imported	
420	Info	Firewall Stateful Configuration Created	
421	Info	Firewall Stateful Configuration Deleted	
422	Info	Firewall Stateful Configuration Updated	
423	Info	Firewall Stateful Configuration	

ID	Severity	Event	Description or Solution
		Exported	
424	Info	Firewall Stateful Configuration Imported	
460	Info	Application Type Created	An administrator configured a new IPS network application definition.
461	Info	Application Type Deleted	An administrator removed an IPS network application definition.
462	Info	Application Type Updated	An administrator changed an existing IPS network application definition.
463	Info	Application Type Exported	An administrator downloaded an IPS network application definition.
464	Info	Application Type Imported	An administrator uploaded an IPS network application definition.
470	Info	Intrusion Prevention Rule Created	
471	Info	Intrusion Prevention Rule Deleted	
472	Info	Intrusion Prevention Rule Updated	
473	Info	Intrusion Prevention Rule Exported	
474	Info	Intrusion Prevention Rule Imported	
480	Info	Integrity Monitoring Rule Created	
481	Info	Integrity Monitoring Rule Deleted	
482	Info	Integrity Monitoring Rule Updated	
483	Info	Integrity Monitoring Rule Exported	
484	Info	Integrity Monitoring Rule Imported	
490	Info	Log Inspection Rule Created	

ID	Severity	Event	Description or Solution
491	Info	Log Inspection Rule Deleted	
492	Info	Log Inspection Rule Updated	
493	Info	Log Inspection Rule Exported	
494	Info	Log Inspection Rule Imported	
495	Info	Log Inspection Decoder Created	
496	Info	Log Inspection Decoder Deleted	
497	Info	Log Inspection Decoder Updated	
498	Info	Log Inspection Decoder Exported	
499	Info	Log Inspection Decoder Imported	
505	Info	Context Created	
506	Info	Context Deleted	
507	Info	Context Updated	
508	Info	Context Exported	
509	Info	Context Imported	
510	Info	IP List Created	
511	Info	IP List Deleted	
512	Info	IP List Updated	
513	Info	IP List Exported	
514	Info	IP List Imported	
520	Info	Port List Created	
521	Info	Port List Deleted	
522	Info	Port List Updated	
523	Info	Port List Exported	
524	Info	Port List Imported	
525	Info	Scan Cache Configuration Created	
526	Info	Scan Cache Configuration Exported	
527	Info	Scan Cache Configuration Updated	
530	Info	MAC List Created	
531	Info	MAC List Deleted	

ID	Severity	Event	Description or Solution
532	Info	MAC List Updated	
533	Info	MAC List Exported	
534	Info	MAC List Imported	
540	Info	Proxy Created	
541	Info	Proxy Deleted	
542	Info	Proxy Updated	
543	Info	Proxy Exported	
544	Info	Proxy Imported	
550	Info	Schedule Created	
551	Info	Schedule Deleted	
552	Info	Schedule Updated	
553	Info	Schedule Exported	
554	Info	Schedule Imported	
560	Info	Scheduled Task Created	
561	Info	Scheduled Task Deleted	
562	Info	Scheduled Task Updated	
563	Info	Scheduled Task Manually Executed	
564	Info	Scheduled Task Started	
565	Info	Backup Finished	
566	Error	Backup Failed	
567	Info	Sending Outstanding Alert Summary	
568	Warning	Failed To Send Outstanding Alert Summary	
569	Warning	Email Failed	An e-mail notification could not be sent. Verify that your SMTP settings are correct.
570	Info	Sending Report	
571	Warning	Failed To Send Report	
572	Error	Invalid Report Jar	
573	Info	Asset Value Created	
574	Info	Asset Value Deleted	
575	Info	Asset Value Updated	

ID	Severity	Event	Description or Solution
576	Error	Report Uninstall Failed	
577	Error	Report Uninstalled	
578	Warning	Integrity Monitoring Rules Require Configuration	
580	Warning	Application Type Port List Misconfiguration	
581	Warning	Application Type Port List Misconfiguration Resolved	
582	Warning	Intrusion Prevention Rules Require Configuration	
583	Info	Intrusion Prevention Rules Require Configuration Resolved	
584	Warning	Application Types Require Configuration	IPS rules require network application definitions, and cannot correctly scan traffic until you define them.
585	Info	Integrity Monitoring Rules Require Configuration Resolved	
586	Warning	Log Inspection Rules Require Configuration	
587	Info	Log Inspection Rules Require Configuration Resolved	
588	Warning	Log Inspection Rules Require Log Files	
589	Info	Log Inspection Rules Require Log Files Resolved	
590	Warning	Scheduled Task Unknown Type	

ID	Severity	Event	Description or Solution
591	Info	Relay Group Created	
592	Info	Relay Group Updated	
593	Info	Relay Group Deleted	
594	Info	Event-Based Task Created	
595	Info	Event-Based Task Deleted	
596	Info	Event-Based Task Updated	
597	Info	Event-Based Task Triggered	
600	Info	User Signed In	
601	Info	User Signed Out	
602	Info	User Timed Out	
603	Info	User Locked Out	
604	Info	User Unlocked	
605	Info	User Session Terminated	
608	Error	User Session Validation Failed	Deep Security Manager could not confirm that a session was initiated after successful authentication. The user will be redirected to the login page, and asked to re-authenticate. This could be normal if the authenticated session list was cleared.
609	Error	User Made Invalid Request	Deep Security Manager received invalid request to access audit data (events). Access was denied.
610	Info	User Session Validated	
611	Info	User Viewed Firewall Event	
613	Info	User Viewed Intrusion Prevention Event	
615	Info	User Viewed System Event	
616	Info	User Viewed Integrity Monitoring Event	
617	Info	User Viewed Log Inspection Event	
618	Info	User Viewed Identified File Detail	

ID	Severity	Event	Description or Solution
619	Info	User Viewed Anti-Malware Event	
620	Info	User Viewed Web Reputation Event	
621	Info	User Signed In As Tenant	
622	Info	Access from Primary Tenant Enabled	
623	Info	Access from Primary Tenant Disabled	
624	Info	Access from Primary Tenant Allowed	
625	Info	Access from Primary Tenant Revoked	
626	Info	Access from Primary Tenant Expired	
630	Info	Syslog Configuration Created	
631	Info	Syslog Configuration Deleted	
632	Info	Syslog Configuration Updated	
633	Info	Syslog Configuration Exported	
634	Info	Syslog Configuration Imported	
650	Info	User Created	
651	Info	User Deleted	
652	Info	User Updated	
653	Info	User Password Set	
656	Info	API Key Created	
657	Info	API Key Deleted	
658	Info	API Key Updated	
660	Info	Role Created	

ID	Severity	Event	Description or Solution
661	Info	Role Deleted	
662	Info	Role Updated	
663	Info	Roles Imported	
664	Info	Roles Exported	
670	Info	Contact Created	
671	Info	Contact Deleted	
672	Info	Contact Updated	
673	Info	API Key Locked Out	
674	Info	API Key Unlocked	
675	Error	API Key Session Validation Failed	
676	Error	API Key Made Invalid Request	
678	Info	API Key Expired	
680	Info	Created master encryption key	For details, see the masterkey parameter.
681	Info	Exported master encryption key	For details, see the masterkey parameter.
682	Info	Imported master encryption key	For details, see the masterkey parameter.
690	Info	Microservice API Key Created	
691	Info	Microservice API Key Deleted	
692	Info	Microservice API Key Updated	
693	Info	Microservice API Key Locked Out	
694	Info	Microservice API Key Unlocked	
695	Error	Microservice API Key Session Validation Failed	
696	Info	Microservice API Key Expired	
700	Info	Agent Software Installed	
701	Error	Agent Software Installation Failed	
702	Info	Credentials Generated	
703	Error	Credential Generation Failed	

ID	Severity	Event	Description or Solution
704	Info	Activated	
705	Error	Activation Failed	This can occur if agent self-protection is enabled. On the Deep Security Manager, go to Computer editor ¹ > Settings > General . In Agent Self Protection , and then either deselect Prevent local end-users from uninstalling, stopping, or otherwise modifying the Agent or enter a password for local override.
706	Info	Software Update: Agent Software Upgraded	
707	Warning	Software Update: Agent Software Upgrade Failed	Refer to the event details for more information about why the upgrade was not successful.
708	Info	Deactivated	
709	Error	Deactivation Failed	
710	Info	Events Retrieved	
711	Info	Agent Software Deployed	
712	Error	Agent Software Deployment Failed	This can occur if agent self-protection is enabled. On the Deep Security Manager, go to Computer editor ² > Settings > General . In Agent Self Protection , and then either deselect Prevent local end-users from uninstalling, stopping, or otherwise modifying the Agent or enter a password for local override.
713	Info	Agent Software Removed	
714	Error	Agent Software Removal Failed	This can occur if agent self-protection is enabled. On the Deep Security Manager, go to Computer editor ³ > Settings > General . In Agent Self Protection , and then either deselect Prevent local end-users from uninstalling, stopping, or otherwise modifying the Agent or enter a password for local override.
715	Info	Agent/Appliance Version Changed	

¹To open the Computer editor, go to the Computers page and double-click the computer that you want to edit (or select the computer and click Details).

²To open the Computer editor, go to the Computers page and double-click the computer that you want to edit (or select the computer and click Details).

³To open the Computer editor, go to the Computers page and double-click the computer that you want to edit (or select the computer and click Details).

ID	Severity	Event	Description or Solution
716	Info	Reactivation Attempted by Unknown Agent	An agent that is currently unknown to the Deep Security Manager has attempted reactivation. This usually happens when a computer was deleted from Deep Security Manager without first removing the agent on the computer. For more information, see the 'Reactivation Attempted by Unknown Agent' section in Agent settings .
720	Info	Policy Sent	Agent/Appliance updated.
721	Error	Send Policy Failed	
722	Warning	Get Interfaces Failed	
723	Info	Get Interfaces Failure Resolved	
724	Warning	Insufficient Disk Space	An agent detected low disk space. Free space on the computer. See "Warning: Insufficient disk space" on page 1402 .
725	Warning	Events Suppressed	
726	Warning	Get Agent/Appliance Events Failed	Manager was unable to retrieve Events from Agent/Appliance. This error does not mean that the data was lost on the Agent/Appliance. This error is normally caused by a network interruption while events are being transferred. Clear the error and run a "Check Status" to retry the operation.
727	Info	Get Agent/Appliance Events Failure Resolved	
728	Error	Get Events Failed	Manager was unable to retrieve audit data from Agent/Appliance. This error does not mean that the data was lost on the Agent/Appliance. This error is normally caused by a network interruption while events are being transferred. Clear the error and run a "Get Events Now" to retry the operation.
729	Info	Get Events Failure Resolved	
730	Error	Offline	Manager cannot communicate with Computer. Usually, however, the offline Agent is still protecting the computer with its last configured settings. See Computer and Agent/Appliance Status and "Offline" agent" on page 1918 .
731	Info	Back Online	
732	Error	Firewall Engine Offline	The Firewall Engine is offline and traffic is flowing unfiltered. This is normally due to an error during installation or verification of the driver on the computer's OS platform. Check the status of the network driver at the computer to ensure it is properly loaded.

ID	Severity	Event	Description or Solution
733	Info	Firewall Engine Back Online	
734	Warning	Computer Clock Change	A clock change has occurred on the Computer which exceeds the maximum allowed specified in Computer or Policy editor ¹ > Settings > General > Heartbeat area. Investigate what has caused the clock change on the computer.
735	Warning	Misconfiguration Detected	The Agent's configuration does not match the configuration indicated in the Manager's records. This is typically because of a recent backup restoration of the Manager or the Agent. Unanticipated misconfiguration warnings should be investigated.
736	Info	Check Status Failure Resolved	
737	Error	Check Status Failed	See "Error: Check Status Failed" on page 1382 .
738	Error	Intrusion Prevention Engine Offline	The Intrusion Prevention Engine is offline and traffic is flowing unfiltered. This is normally due to an error during installation or verification of the driver on the computer's OS platform. Check the status of the network driver at the computer to ensure it is properly loaded.
739	Info	Intrusion Prevention Engine Back Online	
740	Error	Agent/Appliance Error	
741	Warning	Abnormal Restart Detected	
742	Warning	Communications Problem	The Agent is having problems communicating its status to Manager. It usually indicates network or load congestion in the Agent --> Manager direction. Further investigation is warranted if the situation persists
743	Info	Communications Problem Resolved	
745	Warning	Events Truncated	
748	Error	Log Inspection Engine Offline	
749	Info	Log Inspection Engine Back Online	
750	Warning	Last Automatic	

¹You can change these settings for a policy or for a specific computer. To change the settings for a policy, go to the Policies page and double-click the policy that you want to edit (or select the policy and click Details). To change the settings for a computer, go to the Computers page and double-click the computer that you want to edit (or select the computer and click Details).

ID	Severity	Event	Description or Solution
		Retry	
755	Info	Deep Security Manager Version Compatibility Resolved	
756	Warning	Deep Security Manager Upgrade Recommended (Incompatible Security Update (s))	Each security module rule (such as Firewall, Anti-Malware, and the others) has a specific minimum Deep Security Manager version that's required in order for the rule to run. Your current Deep Security Manager version is less than the rule's minimum supported version. Upgrade your Deep Security Manager to clear the warning and run the rule.
760	Info	Agent/Appliance Version Compatibility Resolved	
761	Warning	Agent/Appliance Upgrade Recommended	
762	Warning	Agent/Appliance Upgrade Required	Your current Deep Security Agent or Deep Security Virtual Appliance version is less than the Deep Security Manager's minimum supported version. Upgrade your Agent/Appliance.
763	Error	Incompatible Agent/Appliance Version	Your current Deep Security Manager version is less than the Deep Security Agent or Deep Security Virtual Appliance's minimum supported version. Upgrade your manager.
764	Warning	Agent/Appliance Upgrade Recommended (Incompatible Security Update (s))	Each security module rule (such as Firewall, Anti-Malware, and the others) has a specific minimum Deep Security Agent or Deep Security Virtual Appliance version that's required in order for the rule to run. Your current Deep Security Agent or Deep Security Virtual Appliance version is less than the rule's minimum supported version. Upgrade your Deep Security Agent or Deep Security Virtual Appliance to clear the warning and run the rule.
765	Error	Computer Reboot Required	
766	Warning	Network Engine Mode Configuration Incompatibility	

ID	Severity	Event	Description or Solution
767	Warning	Network Engine Mode Version Incompatibility	
768	Warning	Network Engine Mode Incompatibility Resolved	
770	Warning	Agent/Appliance Heartbeat Rejected	
771	Warning	Contact by Unrecognized Client	See " Troubleshoot event ID 771 "Contact by Unrecognized Client" " on page 1373.
780	Info	Recommendation Scan Failure Resolved	
781	Warning	Recommendation Scan Failure	See " Troubleshooting: Recommendation Scan Failure " on page 715.
782	Info	Rebuild Baseline Failure Resolved	
783	Warning	Rebuild Baseline Failure	
784	Info	Security Update: Security Update Check and Download Successful	
785	Warning	Security Update: Security Update Check and Download Failed	
786	Info	Scan For Change Failure Resolved	
787	Warning	Scan For Change Failure	
790	Info	Agent-Initiated Activation Requested	
791	Warning	Agent-Initiated Activation Failure	
792	Info	Manual Malware Scan Failure Resolved	
793	Warning	Manual Malware Scan Failure	A Malware Scan has failed. Use the VMware vCenter console to check the status of the VM on which the scan failed. See also " Anti-Malware scan failures and

ID	Severity	Event	Description or Solution
			cancellations" on page 1133.
794	Info	Scheduled Malware Scan Failure Resolved	
795	Warning	Scheduled Malware Scan Failure	A scheduled Malware Scan has failed. Use the VMware vCenter console to check the status of the VM on which the scan failed. See also "Anti-Malware scan failures and cancellations" on page 1133.
796	Warning	Scheduled Malware Scan Task has been Missed	This occurs when a scheduled Malware Scan is initiated on a computer when a previous scan is still pending. This typically indicates that Malware Scans are being scheduled too frequently.
797	Info	Malware Scan Cancellation Failure Resolved	
798	Warning	Malware Scan Cancellation Failure	A Malware Scan cancellation has failed. Use the VMware vCenter console to check the status of the VM on which the scan failed.
799	Warning	Malware Scan Stalled	A Malware Scan has stalled. Use the VMware vCenter console to check the status of the VM on which the scan stalled.
800	Info	Alert Dismissed	
801	Info	Error Dismissed	
803	Warning	Agent Configuration Package too Large	
804	Error	Intrusion Prevention Rule Compiler Failed	
805	Error	Intrusion Prevention Rules Failed to Compile	
806	Error	Intrusion Prevention Rules Failed to Compile	
850	Warning	Reconnaissance Detected: Computer OS Fingerprint Probe	See "Warning: Reconnaissance Detected" on page 1402
851	Warning	Reconnaissance Detected: Network or Port Scan	See "Warning: Reconnaissance Detected" on page 1402
852	Warning	Reconnaissance Detected: TCP Null Scan	See "Warning: Reconnaissance Detected" on page 1402
853	Warning	Reconnaissance	See "Warning: Reconnaissance Detected" on page 1402

ID	Severity	Event	Description or Solution
		Detected: TCP SYNFIN Scan	
854	Warning	Reconnaissance Detected: TCP Xmas Scan	See " Warning: Reconnaissance Detected " on page 1402
900	Info	Deep Security Manager Audit Started	
901	Info	Deep Security Manager Audit Shutdown	
902	Info	Deep Security Manager Installed	
903	Warning	License Related Configuration Change	
904	Info	Diagnostic Logging Enabled	
905	Info	Diagnostic Logging Completed	
910	Info	Diagnostic Package Generated	
911	Info	Diagnostic Package Exported	
912	Info	Diagnostic Package Uploaded	
913	Error	Automatic Diagnostic Package Error	
914	Info	Identified File Deletion Succeeded	
915	Info	Identified File Deletion Failed	
916	Info	Identified File Download Succeeded	
917	Info	Identified File Download Failed	
918	Info	Identified File Administration Utility Download Succeeded	

ID	Severity	Event	Description or Solution
919	Info	Identified File Not Found	
920	Info	Usage Information Generated	
921	Info	Usage Information Package Exported	
922	Info	Usage Information Package Uploaded	
923	Error	Usage Information Package Error	
924	Warning	File cannot be analyzed or quarantined (VM maximum disk space used to store identified files exceeded)	The Anti-Malware module was unable to analyze or quarantine a file because the VM maximum disk space used to store identified files was reached. To change the maximum disk space for identified files setting, open the computer or policy editor and go to the Anti-malware > Advanced tab.
925	Warning	File cannot be analyzed or quarantined (maximum disk space used to store identified files exceeded)	The Anti-Malware module was unable to analyze or quarantine a file because the maximum disk space used to store identified files was reached. To change the maximum disk space for identified files setting, open the computer or policy editor and go to the Anti-malware > Advanced tab.
926	Warning	Smart Protection Server Disconnected for Smart Scan	See "Troubleshoot "Smart Protection Server disconnected" errors" on page 1374.
927	Info	Smart Protection Server Connected for Smart Scan	
928	Info	Identified File Restoration Succeeded	
929	Warning	Identified File Restoration Failed	
930	Info	Certificate Accepted	
931	Info	Certificate Deleted	
932	Warning	Smart Protection Server Disconnected for Web Reputation	See "Troubleshoot "Smart Protection Server disconnected" errors" on page 1374.
933	Info	Smart Protection Server Connected	

ID	Severity	Event	Description or Solution
		for Web Reputation	
934	Info	Software Update: Anti-Malware Windows Platform Update Successful	
935	Error	Software Update: Anti-Malware Windows Platform Update Failed	See " Anti-Malware Windows platform update failed " on page 1924
936	Info	Submission of identified file to Deep Discovery Analyzer succeeded	
937	Info	Submission of identified file to Deep Discovery Analyzer failed	
938	Info	Identified File Submission Queued	
940	Info	Auto-Tag Rule Created	
941	Info	Auto-Tag Rule Deleted	
942	Info	Auto-Tag Rule Updated	
943	Info	Tag Deleted	
944	Info	Tag Created	
945	Warning	Census, Good File Reputation, and Predictive Machine Learning Service Disconnected	
946	Info	Census, Good File Reputation, and Predictive Machine Learning Service Connected	
947	Info	FIPS Mode Enabled	
948	Info	FIPS Mode Disabled	

ID	Severity	Event	Description or Solution
949	Warning	Computer reboot is required to complete the Deep Security Agent installation with Windows installer	A computer reboot is required to complete the Deep Security Agent installation with Windows installer.
950	Warning	A computer reboot is required to enable Deep Security Agent protection	A computer reboot is required to disable Windows Defender and enable Deep Security Agent protection.
970	Info	Command Line Utility Started	
978	Info	Command Line Utility Failed	
979	Info	Command Line Utility Shutdown	Deep Security Manager was manually stopped.
980	Info	System Information Exported	
990	Info	Manager Node Added	
991	Info	Manager Node Decommissioned	
992	Info	Manager Node Updated	
995	Info	Connection to the Certified Safe Software Service has been restored	
996	Warning	Unable to connect to the Certified Safe Software Service	
997	Error	Tagging Error	
998	Error	System Event Notification Error	
999	Error	Internal Software Error	
1101	Error	Plug-in Installation Failed	
1102	Info	Plug-in Installed	
1103	Error	Plug-in Upgrade Failed	
1104	Info	Plug-in Upgraded	
1105	Error	Plug-in Start	

ID	Severity	Event	Description or Solution
		Failed	
1106	Error	Plug-in Uninstall Failed	
1107	Info	Plug-in Uninstalled	
1108	Info	Plug-in Started	
1109	Info	Plug-in Stopped	
1110	Error	Software Package Not Found	Agent software package was not found or a newer package is required.
1111	Info	Software Package Found	
1112	Error	Kernel Unsupported	The Linux driver cannot be installed because your computer may have been upgraded to an unsupported kernel. For more information, see " Linux kernel compatibility " on page 349 .
1204	Info	Identified file download requested	The download request has been sent. Please check for event ID 1209 for the latest update. Files that are "Ready for download" will be available for 24 hours.
1205	Info	Identified file download request failed	The download request could not be sent successfully.
1208	Info	Identified file download request timeout	The download request has timeout due to reaching the 2-day limit.
1209	Info	Identified file is ready for download	Identified file is ready for download. Please download the file within 24 hours.
1500	Info	Malware Scan Configuration Created	
1501	Info	Malware Scan Configuration Deleted	
1502	Info	Malware Scan Configuration Updated	
1503	Info	Malware Scan Configuration Exported	
1504	Info	Malware Scan Configuration Imported	
1505	Info	Directory List Created	
1506	Info	Directory List Deleted	

ID	Severity	Event	Description or Solution
1507	Info	Directory List Updated	
1508	Info	Directory List Exported	
1509	Info	Directory List Imported	
1510	Info	File Extension List Created	
1511	Info	File Extension List Deleted	
1512	Info	File Extension List Updated	
1513	Info	File Extension List Exported	
1514	Info	File Extension List Imported	
1515	Info	File List Created	
1516	Info	File List Deleted	
1517	Info	File List Updated	
1518	Info	File List Exported	
1519	Info	File List Imported	
1520	Info	Manual Malware Scan Pending	
1521	Info	Manual Malware Scan Started	
1522	Info	Manual Malware Scan Completed	
1523	Info	Scheduled Malware Scan Started	
1524	Info	Scheduled Malware Scan Completed	
1525	Info	Manual Malware Scan Cancellation In Progress	
1526	Info	Manual Malware Scan Cancellation	This event can have several causes. See "Anti-Malware scan failures and cancellations" on page 1133.
1527	Info	Scheduled Malware Scan Cancellation In Progress	
1528	Info	Scheduled Malware Scan Cancellation	This event can have several causes. See "Anti-Malware scan failures and cancellations" on page 1133.

ID	Severity	Event	Description or Solution
1529	Info	Manual Malware Scan Paused	
1530	Info	Manual Malware Scan Resumed	
1531	Info	Scheduled Malware Scan Paused	
1532	Info	Scheduled Malware Scan Resumed	
1533	Info	A computer reboot is required to complete an Anti-Malware cleanup or restoration task	A computer reboot is required to complete an Anti-Malware cleanup or restoration task.
1534	Error	Computer reboot required for Anti-Malware protection	
1535	Info	Anti-Malware cleanup task must be performed manually	
1536	Info	Quick Malware Scan Pending	
1537	Info	Quick Malware Scan Started	
1538	Info	Quick Malware Scan Completed	
1539	Info	Quick Malware Scan Cancellation In Progress	
1540	Info	Quick Malware Scan Cancellation	This event can have several causes. See "Anti-Malware scan failures and cancellations" on page 1133.
1541	Info	Quick Malware Scan Paused	
1542	Info	Quick Malware Scan Failure Resolved	
1543	Warning	Quick Malware Scan Failure	See "Anti-Malware scan failures and cancellations" on page 1133.
1544	Info	Quick Malware Scan Resumed	
1545	Info	Files could not be scanned for	Anti-malware could not scan a file because its file path exceeded the maximum number of characters. Maximum file

ID	Severity	Event	Description or Solution
		malware	path length varies by OS and file system. To prevent this problem, try moving the file to a directory path and file name with fewer characters.
1546	Info	Files could not be scanned for malware	Anti-malware could not scan a file because its location exceeded the maximum directory depth. To prevent this problem, try reducing the number of layers of nested directories.
1547	Info	Scheduled Malware Scan Task has been cancelled	
1550	Info	Web Reputation Settings Updated	
1551	Info	Malware Scan Configuration Updated	
1552	Info	Integrity Configuration Updated	
1553	Info	Log Inspection Configuration Updated	
1554	Info	Firewall Stateful Configuration Updated	
1555	Info	Intrusion Prevention Configuration Updated	
1556	Info	Anti-Malware scan exclusion setting update	
1600	Info	Relay Group Update Requested	
1601	Info	Relay Group Update Success	
1602	Error	Relay Group Update Failed	
1603	Info	Security Update: Security Update Rollback Success	
1604	Warning	Security Update: Security Update Rollback Failure	
1605	Info	Successfully send file back up	

ID	Severity	Event	Description or Solution
		command to host	
1606	Warning	Failed to send file back up command to host	
1607	Info	Successfully back up file	
1608	Error	Failed to back up file	
1650	Warning	Anti-Malware protection is not enabled or is out of date	
1651	Info	Anti-Malware module is ready	
1660	Info	Rebuild Baseline Started	
1661	Info	Rebuild Baseline Paused	
1662	Info	Rebuild Baseline Resumed	
1663	Warning	Rebuild Baseline Failure	
1664	Warning	Rebuild Baseline Stalled	
1665	Info	Rebuild Baseline Completed	
1666	Info	Scan for Integrity Started	
1667	Info	Scan for Integrity Paused	
1668	Info	Scan for Integrity Resumed	
1669	Warning	Scan for Integrity Failure	
1670	Warning	Scan for Integrity Stalled	
1671	Info	Scan for Integrity Completed	
1675	Error	Integrity Monitoring Engine Offline	
1676	Info	Integrity Monitoring Engine Back Online	
1677	Error	Trusted Platform Module Error	

ID	Severity	Event	Description or Solution
1678	Info	Trusted Platform Module Register Values Loaded	
1679	Warning	Trusted Platform Module Register Values Changed	
1680	Info	Trusted Platform Module Checking Disabled	
1681	Info	Trusted Platform Module Information Unreliable	
1700	Info	No Agent Detected	
1800	Error	Deep Security Protection Module Failure	
1801	Info	Deep Security Protection Module Back to Normal	
1900	Info	Cloud Account Added	
1901	Info	Cloud Account Removed	
1902	Info	Cloud Account Updated	
1903	Info	Cloud Account Synchronization In Progress	
1904	Info	Cloud Account Synchronization Finished	
1905	Error	Cloud Account Synchronization Failed	
1906	Info	Cloud Account Synchronization Requested	
1907	Info	Cloud account Synchronization Cancelled	
1908	Info	AWS Account Synchronization Requested	
1909	Info	AWS Account	

ID	Severity	Event	Description or Solution
		Synchronization Finished	
1910	Error	AWS Account Synchronization Failed	
1911	Info	AWS Account Added	
1912	Info	AWS Account Removed	
1913	Info	AWS Account Updated	
1914	Info	Azure Account Added	
1915	Info	Azure Account Removed	
1916	Info	Azure Account Updated	
1917	Info	Azure Account Synchronization Finished	
1918	Error	Azure Account Synchronization Failed	
1919	Info	Azure Account Synchronization Requested	
1920	Warning	Azure Account Synchronization Completed but with Errors	
1921	Info	vCloud Account Added	
1922	Info	vCloud Account Removed	
1923	Info	vCloud Account Updated	
1924	Info	vCloud Account Synchronization Finished	
1925	Error	vCloud Account Synchronization Failed	
1926	Info	vCloud Account Synchronization Requested	
1927	Info	Upgrade	

ID	Severity	Event	Description or Solution
		Connector to AWS Account Requested	
1928	Warning	AWS Account Update Failed	
1929	Info	Upgrade Connector to AWS Account Finished	
1950	Info	Tenant Created	
1951	Info	Tenant Deleted	
1952	Info	Tenant Updated	
1953	Info	Tenant Database Server Created	
1954	Info	Tenant Database Server Deleted	
1955	Info	Tenant Database Server Updated	
1956	Info	Tenant Exported	
1957	Error	Tenant Initialization Failure	
1958	Info	Tenant Features Updated	
2000	Info	Scan Cache Configuration Object Added	
2001	Info	Scan Cache Configuration Object Removed	
2002	Info	Scan Cache Configuration Object Updated	
2100	Info	Deep Security as a Service Subscription Started	
2101	Info	Deep Security as a Service Subscription Canceled	
2102	Info	Cleverbridge Quantity Updated	
2103	Warning	Cleverbridge Quantity Not Updated	
2104	Info	Cleverbridge	

ID	Severity	Event	Description or Solution
		Quantity Reset	
2105	Warning	Cleverbridge Quantity Not Reset	
2106	Info	Cleverbridge Billing Date Set	
2107	Warning	Cleverbridge Billing Date Not Set	
2108	Info	Deep Security as a Service Subscription Payment Received	
2109	Warning	Deep Security as a Service Subscription Payment Not Received	
2110	Info	Cleverbridge Notification Received	
2111	Info	Deep Security as a Service Subscription Deactivated	
2112	Info	Account Balance Reset	
2113	Info	Agent Installation Requested	
2114	Info	AWS Billing Job Started	
2115	Info	AWS Billing Job Completed	
2116	Error	AWS Billing failure	Deep Security Manager sent a billing usage record to AWS using the AWS SDK, which the SDK returned with an exception. If the problem persists, contact your support provider.
2117	Info	Entitlement Created	
2118	Info	Entitlement Updated	
2119	Error	Agent Activation Prevented Due to AWS Metering Billing Usage Data	

ID	Severity	Event	Description or Solution
		Submission Failure	
2120	Error	AWS Billing failure	Deep Security Manager encountered an error while executing an AWS billing job. If the problem persists, contact your support provider.
2123	Error	Azure Marketplace Billing Job Failed	The job used to send host usage statistics to Azure Marketplace for consumption-based billing failed. See the description in the event for details about the error that caused this event.
2126		Event Storage Settings Publish Job Failed	
2127	Info	Account Details Publish Job Started	
2128	Info	Account Details Publish Job Completed	
2129	Error	Account Details Publish Job Failed	
2200	Info	Software Update: Anti-Malware Module Installation Started	
2201	Info	Software Update: Anti-Malware Module Installation Successful	This event is also triggered by installing Application Control or Integrity Monitoring because they share the same framework as Anti-Malware.
2202	Warning	Software Update: Anti-Malware Module Installation Failed	
2203	Info	Software Update: Anti-Malware Module Download Successful	
2204	Info	Security Update: Pattern Update on Agents/Appliances Successful	
2205	Warning	Security Update: Pattern Update on Agents/Appliances Failed	
2206	Info	Security Update: Pattern Update on	

ID	Severity	Event	Description or Solution
		Agents/Appliances Skipped	
2209	Warning	Anti-Malware Engine with Basic Functions	Anti-Malware engine has only basic functions available. See Anti-Malware Engine has only Basic Functions for details.
2300	Info	Software Update: Web Reputation Module Installation Started	
2301	Info	Software Update: Web Reputation Module Installation Successful	
2302	Warning	Software Update: Web Reputation Module Installation Failed	
2303	Info	Software Update: Web Reputation Download Successful	
2400	Info	Software Update: Firewall Module Installation Started	
2401	Info	Software Update: Firewall Module Installation Successful	
2402	Warning	Software Update: Firewall Module Installation Failed	
2403	Info	Software Update: Firewall Module Download Successful	
2500	Info	Software Update: Intrusion Prevention Module Installation Started	
2501	Info	Software Update: Intrusion Prevention Module Installation Successful	
2502	Warning	Software Update: Intrusion Prevention Module	

ID	Severity	Event	Description or Solution
		Installation Failed	
2503	Info	Software Update: Intrusion Prevention Module Download Successful	
2600	Info	Software Update: Integrity Monitoring Module Installation Started	
2601	Info	Software Update: Integrity Monitoring Module Installation Successful	
2602	Warning	Software Update: Integrity Monitoring Module Installation Failed	
2603	Info	Software Update: Integrity Monitoring Module Download Successful	
2604	Info	A computer reboot is required to complete Integrity Monitoring protection	
2700	Info	Software Update: Log Inspection Module Installation Started	
2701	Info	Software Update: Log Inspection Module Installation Successful	
2702	Warning	Software Update: Log Inspection Module Installation Failed	
2703	Info	Software Update: Log Inspection Module Download Successful	
2800	Info	Software Update: Software	

ID	Severity	Event	Description or Solution
		Automatically Downloaded	
2801	Error	Software Update: Unable to retrieve Download Center inventory	
2802	Error	Software Update: Unable to download software from Download Center	
2803	Info	Online Help Update Started	
2804	Info	Online Help Update Ended	
2805	Info	Online Help Update Success	
2806	Warning	Online Help Update Failed	
2900	Info	Software Update: Relay Module Installation Started	
2901	Info	Software Update: Relay Module Installation Successful	
2902	Warning	Software Update: Relay Module Installation Failed	
2903	Info	Software Update: Relay Module Download Successful	
2904	Info	VMware NSX Synchronization Finished	
2905	Error	VMware NSX Synchronization Failed	
2906	Info	Agent Self-Protection enabled	Agent self-protection was enabled via the Deep Security Manager.
2907	Info	Agent Self-Protection disabled	
2908	Info	Agent Self-Protection enabled	Agent self-protection was enabled via the command line on the Deep Security Agent.

ID	Severity	Event	Description or Solution
2909	Info	Agent Self-Protection disabled	
2915	Info	Data migration complete	
2916	Warning	Data migration finished with error	
2920	Info	Querying report from DDAn Finished	
2921	Error	Querying report from DDAn Failed	
2922	Info	Submission to Deep Discovery Analyzer processed	
2923	Error	File submission to Deep Discovery Analyzer Failed	
2924	Info	Security Update: Suspicious Object Check and Update Successful	
2925	Error	Security Update: Suspicious Object Check and Update Failed	
2926	Warning	Submission to Deep Discovery Analyzer queued	
2930	Info	File back up pending	
2931	Info	Smart Folder Added	
2932	Info	Smart Folder Removed	
2933	Info	Smart Folder Updated	
2934	Error	Failed to send Amazon SNS message	
2935	Info	System resumed sending SNS messages	
2936	Info	Inactive User Deleted	

ID	Severity	Event	Description or Solution
2937	Info	SAML Identity Provider Created	
2938	Info	SAML Identity Provider Updated	
2939	Info	SAML Identity Provider Deleted	
2940	Info	SAML Service Provider Updated	
2941	Error	Failed to Update News	
2942	Info	Performance Profile Created	
2943	Info	Performance Profile Updated	
2944	Info	Performance Profile Deleted	
2945	Info	System Upgrade Started	
2946	Info	System Update Succeeded	
2947	Error	System Upgrade Failed	
2948	Info	Manager Node Upgrade Started	
2949	Info	Manager Node Update Succeeded	
2950	Error	Manager Node Upgrade Failed	A node in a multi-node environment failed to upgrade.
2951	Error	Failed to send TIC message	Managed Detection and Response events failed to send.
2952	Info	System resumed sending TIC messages	
2953	Info	Inactive Agent Cleanup Completed Successfully	Inactive agent cleanup removed computers that have been offline and inactive for a specified period of time. For more information on inactive agent cleanup, see "Automate offline computer removal with inactive agent cleanup" on page 1470.
2954	Warning	Dropped events recorded in the future	
2955	Info	The public CA chain was imported (via the dsm_c command)	

ID	Severity	Event	Description or Solution
2656	Info	The public CA chain was deleted (via the dsm_c command)	
2957	Info	The manager's certificate authority cert was renewed (happens automatically, by default every 10 yrs)	
2958	Info	The default TLS certificate was renewed (happens automatically, by default every 2 yrs)	
2960	Info	Appliance (SVM) Upgrade Requested	Deep Security Manager has received the upgrade request.
2961	Info	Appliance (SVM) Upgrade Started	Deep Security Manager is processing the upgrade.
2962	Info	Appliance (SVM) Upgrade Canceled	The appliance SVM is not available so the upgrade cannot be done. See the description of the system event for the reason.
2963	Info	Appliance (SVM) Upgraded	The appliance SVM is upgraded to the new version and is activated successfully. All guest VMs are auto-activated three minutes after the appliance activation.
2964	Warning	Appliance (SVM) Upgrade Failed	Deep Security Manager encountered one or more errors and failed the upgrade process. For details, see "Troubleshooting the 'Appliance (SVM) Upgrade Failed' system event" on page 1640.
2965	Error	Appliance (SVM) Upgraded but Not Ready	The appliance SVM was upgraded to the newer version but has not yet been activated, or the appliance SVM was activated but your guest VMs have not yet been auto-activated. See the description of the system event for details. You may need to confirm the appliance deployment and manually trigger activation of the appliance or guest VMs.
2969	Info	Scheduled Task Skipped	
2970	Info	GCP Account Added	GCP Account: <GCPaccountname> successfully added. For details, see "Add a Google Cloud Platform account" on page 677.

ID	Severity	Event	Description or Solution
2971	Info	GCP Account Removed	GCP Account: <GCPaccountname> successfully removed. For details, see "Remove a GCP account" on page 680 .
2972	Info	GCP Account Updated	GCP Account: <GCPaccountname> successfully updated. For details, see "Add a Google Cloud Platform account" on page 677 .
2973	Info	GCP Account Synchronization Finished	Synchronize computers completed for GCP Account: <GCPaccountname> For details, see "Synchronize a GCP account" on page 681 .
2974	Error	GCP Account Synchronization Failed	Deep Security Manager was unable to synchronize computers with GCP Account: <GCPaccountname> <detailed_message> For example: Root URL is not valid For details, see "Synchronize a GCP account" on page 681 .
2975	Info	GCP Account Synchronization Requested	A request has been made to synchronize computers with GCP Account: <GCPaccountname> For details, see "Synchronize a GCP account" on page 681 .
2976	Warning	GCP Account Synchronization Completed but with Errors	The GCP Account <GCPaccountname> synchronization operation completed, but information for the following hosts or groups could not be updated with following message: <detailed_message> For example: Project <GCPprojectname>: 403 Required 'compute.machineTypes.list' permission for 'projects/<GCPprojectname>' For details, see "Synchronize a GCP account" on page 681 .
2988	Warning	MQTT Connection Offline	
2989	Info	MQTT Connection Online	
2990	Info	XDR Service	

ID	Severity	Event	Description or Solution
		Registered	
2991	Info	XDR Service Deleted	
2992	Warning	VMware NSX Policy Configuration Conflict	<p>Deep Security Manager has detected that the following NSX-T groups are using different security policies for Endpoint Protection and Network Introspection (E-W):</p> <p><group_names></p> <p>Go to NSX-T and reconfigure the group to use the same security policy.</p> <p>For details, see "Method 3: Synchronize your Deep Security policies to NSX-T 3.x" on page 586.</p>
2993	Warning	XDR Certificate Expired	
2994	Warning	XDR Product Connector Missing	
2995	Info	XDR Certificate Updated	
2996	Warning	XDR Certificate Update Failed	
2997	Warning	MQTT Connection Configuration Failed	
2998	Warning	MQTT Connection Configured	
3000	Info	Software Update: SAP Module Installation Started	
3001	Info	Software Update: SAP Module Installation Successful	
3002	Error	Software Update: SAP Module Installation Failed	
3003	Info	Software Update: SAP Module Download Successful	
3004	Info	SAP VSA is installed	
3005	Error	SAP VSA is not	

ID	Severity	Event	Description or Solution
		installed	
3006	Info	SAP VSA is up-to-date	
3007	Info	SAP VSA is not up-to-date	
3008	Info	SAP: Anti-Malware module is ready	
3009	Error	SAP: Anti-Malware module is not ready	
3200	Info	A computer reboot is required to complete the installation of Activity Monitoring	
3300	Info	Computer Added to vCenter Account	
3301	Warning	Duplicate Hosts with Same Virtual UUID Found	Cannot move the standalone host to vCenter (<vCenter's name>). Deep Security found the following hosts with same virtual UUID (<The UUID>): <Hosts>
3400	Info	Device Control USB device created.	
3401	Info	Device Control USB device updated.	
3402	Info	Device Control USB device deleted.	
3403	Error	Device Control engine offline	The Device Control Engine is offline, so device policies may not be working and may not being applied. This is normally due to an error during engine initializing or the platform being offline (the platform is sometimes called the Anti-Malware Solution Platform, or AMSP, and sometimes called the Trend Micro Solution Platform). Check the status of the platform at the computer.
3404	Info	Device Control engine back online.	
3405	Info	Device Control event exported.	
3406	Info	User viewed Device Control event.	

ID	Severity	Event	Description or Solution
3500	Info	Service Gateway Added	
3501	Info	Service Gateway Removed	
3502	Info	Service Gateway Updated	
7000	Info	Application Control Security Events Exported	An administrator downloaded application control event logs in CSV format.
7007	Info	User Viewed Application Control Event	An administrator dismissed an application control alert. This is normal unless your system has been compromised by an intruder that has gained an administrator login.
7008	Error	Application Control Engine Offline	An agent's application control engine failed to come online. This could happen if you have enabled application control on a computer whose kernel is not supported.
7009	Info	Application Control Engine Online Again	An agent's application control engine restarted.
7010	Info	Application Control Configuration Updated	Deep Security Manager updated the application control settings on an agent.
7011	Info	Software Update: Application Control Module Installation Started	The agent received a policy from Deep Security Manager where application control was selected, but detected that it did not have the application control engine installed or needed to update it, so it began to download it. This is normal when you enable application control on a computer for the first time, or when it has been disabled while application control engine updates were released.
7012	Info	Software Update: Application Control Module Installation Successful	The agent installed the application control engine. The application control engine is also used by the integrity monitoring feature.
7013	Error	Software Update: Application Control Module Installation Failed	The agent could not install the application control engine. This is not normal.
7014	Info	Software Update: Application Control Module Download Successful	The agent finished downloading the application control engine.
7015	Info	Application Control Ruleset Rules Updated	The legacy REST API was used to allow or block software. This message does not occur when administrators perform the same action in the GUI.

ID	Severity	Event	Description or Solution
7020	Info	Application Control Inventory Retrieved	The legacy REST API uploaded a computer's initial allow rules to Deep Security Manager.
7021	Info	Application Control Inventory Scan Started	The application control engine was enabled, and the agent detected that it did not have any allow rules for that computer, so it began to build initial rules based on the currently installed software. This is normal when you enable application control for the first time. This message does not occur when you use the legacy REST API to replace the allow rules.
7022	Info	Application Control Inventory Scan Completed	The agent finished building the initial allow rules for that computer. After this, any new software that is detected which is not in the allow or block rules will, if configured, cause an alert.
7023	Error	Application Control Inventory Scan Failed	The agent could not build the initial allow rules for that computer. This is not normal.
7024	Info	Application Control Software Changes Detected	An administrator allowed or blocked software in the Actions tab, or changed a rule by clicking Change rule in an application control log message. This message does not occur when you use the legacy REST API to replace the allow rules.
7025	Info	Application Control Inventory Scan Requested	You manually forced application control to delete the current rules and rebuild them based on the currently installed software. This could be normal if you needed to change many rules at the same time.
7026	Info	Application Control Maintenance Mode Start Requested	Either an administrator sent or the legacy REST API received the command to enable maintenance mode.
7027	Info	Application Control Maintenance Mode Stop Requested	Either an administrator sent or the legacy REST API received the command to disable maintenance mode.
7028	Info	Application Control Maintenance Mode Started	Maintenance mode was enabled. While enabled, the agent automatically adds updated or newly installed software to its allow rules, indicating that you know and want to allow the software update. The agent continues to apply block rules during this time.
7029	Info	Application Control Maintenance Mode Stopped	Maintenance mode was disabled. Once maintenance mode is stopped, all new or changed software will be considered "unrecognized" until you specifically allow or block it.
7030	Info	Application Control Inventory	The agent began to build the initial allow rules, but an administrator canceled the process.

ID	Severity	Event	Description or Solution
		Scan Cancelled	
7031	Error	Sending Application Control Ruleset Failed	An agent could not download a shared ruleset for application control. This can occur if network connectivity is interrupted (such as a firewall or proxy between the agent and relay), or if there isn't enough free disk space on the agent.
7032	Info	Sending Application Control Ruleset Succeeded	An agent downloaded a shared ruleset for application control. This normally occurs whenever an administrator or the legacy REST API allows or blocks software, or when a different shared ruleset is applied.
7033	Info	Application Control Ruleset Created	The legacy REST API was used to create an application control ruleset. This message does not occur when administrators perform the same action in the GUI.
7034	Info	Application Control Ruleset Updated	The legacy REST API was used to allow or block software via an application control ruleset. This message does not occur when administrators perform the same action in the GUI.
7035	Info	Application Control Ruleset Deleted	The legacy REST API was used to delete an application control ruleset. This message does not occur when administrators perform the same action in the GUI.
7036	Info	Application Control Maintenance Mode Reset Duration Requested	An administrator changed the time period for when maintenance mode is active.
7037	Error	Newly applied ruleset will block some running processes on restart	An administrator applied a new ruleset, but some of the currently running processes exist in block rules. Application control will not terminate the processes, but the next time you reboot or restart those services, depending on your configuration, it will either alert you or block them. If the processes are not authorized, you should terminate them manually. If they are authorized, but are missing from the ruleset, you should add them to the ruleset.
7038	Error	Unresolved software change limit reached	Software changes detected on the file system exceeded the maximum amount. Application control will continue to enforce existing rules, but will not record any more changes, and it will stop displaying any of that computer's software changes. You must resolve and prevent excessive software change.
7040	Error	Incompatible Application Control Ruleset	An application control ruleset could not be assigned to one or more computers because the ruleset is not supported by the installed version of the agent. Typically, the problem is that a hash-based ruleset (which is compatible only with Deep Security Agent 11.0 or newer) has been assigned to an older Deep Security Agent. Deep Security Agent 10.x supports only file-based rulesets. (For details, see "Differences in how Deep Security Agent 10 and 11 compare

ID	Severity	Event	Description or Solution
			files" on page 1075.) To fix this issue, upgrade the Deep Security Agent to version 11.0 or newer. Alternatively, if you are using local rulesets, reset application control for the agent. Or if you are using a shared ruleset, use a shared ruleset that was created with Deep Security 10.x until all agents using the shared ruleset are upgraded to Deep Security Agent 11.0 or newer.
7041	Info	Application Control Ruleset Upgraded	An application control ruleset was upgraded from a file-based ruleset to a hash-based ruleset. (For details, see "Differences in how Deep Security Agent 10 and 11 compare files" on page 1075.)
7042	Info	Application Control Software Inventory Deleted	
7043	Info	A computer reboot is required to complete Application Control protection	
7044	Info	Sending Application Control Ruleset	The Manager is sending Application Control rulesets to the remote agent.
7045	Error	Failed to send Application Control Ruleset	The Manager failed to send the Application Control rulesets to the remote agent.
9100	Info	Move Requested	
9101	Info	Moving	
9102	Warning	Move Failed	See "Migrate agents to Workload Security" on page 1720.
9103	Warning	Move Failed (No Response)	See "Migrate agents to Workload Security" on page 1720.
9104	Warning	Move Failed (Failed to activate)	See "Migrate agents to Workload Security" on page 1720.
9105	Info	Move Complete	
9106	Error	Move Failed (Unmanaged)	See "Migrate agents to Workload Security" on page 1720.
9107	Info	Workload Security Link Created	
9108	Info	Workload Security Link Updated	
9109	Info	Workload Security Link Deleted	

Application Control events

For general best practices related to events, see ["About Deep Security event logging" on page 1125](#).

To see the Application Control events captured by Deep Security, go to **Events & Reports > Events > Application Control Events > Security Events**.

What information is displayed for Application Control events?

These columns can be displayed on the Application Control Events page. You can click **Columns** to select which columns are displayed in the table.

- **Time:** Time the event took place on the computer.
- **Computer:** The computer on which this event was logged. (If the computer has been removed, this entry will read "Unknown Computer".)
- **Event:** The name of the event.
- **Rules:** View event details and change the rule from Allow to Block or vice versa.
- **Ruleset:** Ruleset that's associated with the event.
- **Action:** The action that caused the event to be triggered.
- **Reason:** The reason the event was triggered.
- **Repeat count:** The number of events that are aggregated.
- **Tag(s):** Event tags associated with this event.
- **Path:** Path to the affected file.
- **File:** File affected by the event.
- **User Name:** User that's responsible for executing the unrecognized software.
- **Event Origin:** The Deep Security component from which the event originated.
- **MD5:** MD5 hash.
- **SHA1:** SHA-1 hash.
- **SHA256:** SHA-256 hash.
- **Group:** The name of the group.
- **Group ID:** The ID of the group.
- **User ID:** User ID of the file owner.
- **Process ID:** ID of process that ran the execution.
- **Process Name:** Process that ran the execution.

List of all Application Control events

Note: For system events related to Application Control, see "[System events](#)" on page 1298.

Events
Execution of Unrecognized Software Allowed
Execution of Unrecognized Software Blocked
Execution of Software Blocked by Rule

Anti-malware events

For general best practices related to events, see "[About Deep Security event logging](#)" on page 1125.

To see the anti-malware events captured by Deep Security, go to **Events & Reports > Events > Anti-Malware Events**.

What information is displayed for anti-malware events?

These columns can be displayed on the Anti-Malware Events page. You can click **Columns** to select which columns are displayed in the table.

- **Time:** Time the event took place on the computer.
- **Computer:** The computer on which this event was logged. (If the computer has been removed, this entry will read "Unknown Computer".)
- **Infected File(s):** The location and name of the infected file.
- **Tag(s):** Event tags associated with this event.
- **Malware:** The name of the malware that was found.
- **Action Taken:** Displays the results of the actions specified in the malware scan configuration associated with the event.
 - **Cleaned:** Deep Security successfully terminated processes or deleted registries, files, cookies, or shortcuts, depending on the type of malware.
 - **Clean Failed:** Malware could not be cleaned for a variety of possible reasons.
 - **Deleted:** An infected file was deleted.
 - **Delete Failed:** An infected file could not be deleted for a variety of possible reasons. For example, the file may be locked by another application, is on a CD, or is in use. If possible, Deep Security will delete the infected file once it is released.

- **Quarantined:** An infected file was moved to the identified files folder.
 - **Quarantine Failed:** An infected file could not be quarantined for a variety of possible reasons. For example, the file may be locked by another application, is on a CD, or is in use. If possible, Deep Security will quarantine the infected file once it is released. It is also possible that the "Maximum disk space used to store identified files" (specified on the **Policy/Computer Editor > Anti-Malware > Advanced** tab) has been exceeded.
 - **Access Denied:** Deep Security has prevented the infected file from being accessed without removing the file from the system.
 - **Passed:** Deep Security did not take any action but logged the detection of the malware.
- **Scan Type:** The type of scan that found the malware (Real-Time, Scheduled, or Manual).
 - **Event Origin:** Indicates from which part of the Deep Security system the event originated.
 - **Reason:** The malware scan configuration that was in effect when the malware was detected.
 - **Major Virus Type:** The type of malware detected. Possible values are: Joke, Trojan, Virus, Test, Spyware, Packer, Generic, or Other. For information on these types of malware, see the anti-malware event details or see ["About Anti-Malware" on page 798](#)
 - **Target(s):** The file, process, or registry key (if any) that the malware was trying to affect. If the malware was trying to affect more than one, this field will contain the value "Multiple."
 - **Target Type:** The type of system resource that this malware was trying to affect, such as the file system, a process, or Windows registry.
 - **Container ID:** ID of the Docker container where the malware was found.
 - **Container Image Name:** Image name of the Docker container where the malware was found.
 - **Container Name:** Name of the Docker container where the malware was found.
 - **File MD5:** The MD5 hash of the file.

List of all anti-malware events

ID	Severity	Event
9001	Info	Anti-Malware Scan Started
9002	Info	Anti-Malware Scan Completed
9003	Info	Anti-Malware Scan Terminated Abnormally
9004	Info	Anti-Malware Scan Paused
9005	Info	Anti-Malware Scan Resumed
9006	Info	Anti-Malware Scan Cancelled

ID	Severity	Event
9007	Warning	Anti-Malware Scan Cancel Failed
9008	Warning	Anti-Malware Scan Start Failed
9009	Warning	Anti-Malware Scan Stalled
9010	Error	File cannot be analyzed or quarantined (VM maximum disk space used to store identified files exceeded)
9011	Error	File cannot be analyzed or quarantined (maximum disk space used to store identified files exceeded)
9012	Warning	Smart Protection Server Disconnected for Smart Scan
9013	Info	Smart Protection Server Connected for Smart Scan
9014	Warning	Computer reboot is required for Anti-Malware protection
9016	Info	Anti-Malware Component Update Successful
9017	Error	Anti-Malware Component Update Failed
9018	Error	Files could not be scanned for malware
9019	Error	Directory could not be scanned for malware

Device Control events

For general best practices related to events, see [Events in Workload Security](../events).

To see the Device Control events captured by Workload Security, go to **Events & Reports > Events > Device Control Events > Security Events**.

What information is displayed for Device Control events?

These columns can be displayed on the Device Control Events page. You can click **Columns** to select which columns are displayed in the table.

- **Time:** The time that the event took place on the computer.
- **Computer:** The computer on which this event was logged. (If the computer has been removed, this entry will read "Unknown Computer".)
- **Device Type:** The device type that was accessed to cause the event; for example, USB.
- **Target:** The file name that was accessed that caused the event to be triggered.
- **Accessed By:** The process name that caused the event to be triggered.
- **Action Taken:** The action that Device Control took.
- **Vendor:** The name of the vendor of the device.
- **Model:** The model name or number of the device.
- **Serial Number:** The serial number of the device.
- **Product:** The device name that was accessed to cause the event.





- **Tag(s):** Any event tags associated with this event.
- **Event Origin:** The Workload Security component from which the event originated.

Firewall events

For general best practices related to events, see ["About Deep Security event logging" on page 1125](#).

To see the firewall events captured by Deep Security, go to **Events & Reports > Events > Firewall Events**.

Firewall event icons:

-  Single event
-  Single event with data
-  Folded event
-  Folded event with data

Note: Event folding occurs when multiple events of the same type occur in succession. This saves disk space and protects against DoS attacks that may attempt to overload the logging mechanism.

What information is displayed for firewall events?

These columns can be displayed on the firewall events page. You can click **Columns** to select which columns are displayed in the table.

- **Time:** Time the event took place on the computer.
- **Computer:** The computer on which this event was logged. (If the computer has been removed, this entry will read "Unknown Computer".)
- **Reason:** Log entries on this page are generated either by firewall rules or by firewall stateful configuration settings. If an entry is generated by a firewall rule, the column entry will be prefaced by "Firewall Rule:" followed by the name of the firewall rule. Otherwise the column entry will display the firewall stateful configuration setting that generated the log entry.
- **Tag(s):** Event tags that are applied to this event.

- **Action:** The action taken by the firewall rule or firewall stateful configuration. Possible actions are: Allow, Deny, Force Allow, and Log Only.
- **Rank:** The ranking system provides a way to quantify the importance of intrusion prevention and firewall events. By assigning "asset values" to computers, and assigning "severity values" to intrusion prevention rules and firewall rules, the importance ("rank") of an event is calculated by multiplying the two values together. This allows you to sort events by rank when viewing intrusion prevention or firewall events.
- **Direction:** The direction of the affected packet (incoming or outgoing).
- **Interface:** The MAC address of the interface through which the packet was traveling.
- **Frame Type:** The frame type of the packet in question. Possible values are "IPV4", "IPV6", "ARP", "REVARP", and "Other: XXXX" where XXXX represents the four digit hex code of the frame type.
- **Protocol:** Possible values are "ICMP", "ICMPV6", "IGMP", "GGP", "TCP", "PUP", "UDP", "IDP", "ND", "RAW", "TCP+UDP", AND "Other: nnn" where nnn represents a three digit decimal value.
- **Flags:** Flags set in the packet.
- **Source IP:** The packet's source IP.
- **Source MAC:** The packet's source MAC address.
- **Source Port:** The packet's source port.
- **Destination IP:** The packet's destination IP address.
- **Destination MAC:** The packet's destination MAC address.
- **Destination Port:** The packet's destination port.
- **Packet Size:** The size of the packet in bytes.
- **Repeat Count:** The number of times the event was sequentially repeated.
- **Time (microseconds):** Microsecond resolution for the time the event took place on the computer.
- **Event Origin:** The Deep Security component from which the event originated.

The following columns are also available. They display information for events that are triggered from containers on computers that are protected by Deep Security Agent 12 FR or newer:

- **Interface Type:** Container interface type.
- **Container Name:** Name of the container where the event occurred.
- **Container ID:** Container ID of the container where the event occurred.

- **Image Name:** Image name that was used to create the container where the event occurred.
- **RepoDigest:** A unique digest that identifies the container image.
- **Process Name:** Name of the process (from the container) that caused the event.

Note: Log-only rules will only generate a log entry if the packet in question is not subsequently stopped either by a **deny** rule, or an **allow** rule that excludes it. If the packet is stopped by one of those two rules, *those* rules will generate a log entry and *not* the **log-only** rule. If no subsequent rules stop the packet, the log-only rule will generate an entry.

List of all firewall events

ID	Event	Notes
100	Out Of Connection	A packet was received that was not associated with an existing connection.
101	Invalid Flags	Flag(s) set in a packet were invalid. This event can indicate that a flag does not make sense within the context of a current connection (if any), or that a nonsensical combination of flags. "Firewall Stateful Configuration" must be On for connection context to be assessed.
102	Invalid Sequence	A packet with an invalid sequence number or out-of-window data size was encountered.
103	Invalid ACK	A packet with an invalid acknowledgment number was encountered.
104	Internal Error	
105	CE Flags	A packet has congestion flags set and the policy's Anti Evasion settings use a custom configuration where the TCP Congestion Flags property is set to Log or Deny. (See " Configure anti-evasion settings " on page 921.)
106	Invalid IP	Packet's source IP was not valid.
107	Invalid IP Datagram Length	The length of the IP datagram is less than the length specified in the IP header.
108	Fragmented	A fragmented packet was encountered and fragmented packets are not allowed.
109	Invalid Fragment Offset	
110	First Fragment Too Small	A fragmented packet was encountered, and the size of the first fragment is less than the size of a TCP packet (no data). A packet is dropped with this event when the packet header has the following configuration:

ID	Event	Notes
		<ul style="list-style-type: none"> • Fragment Offset = 0 (The fragment is the first in the packet) • Total length (maximum combined header length) < 120 bytes (the default allowed minimum fragment size) <p>To prevent this event from occurring, configure the policy's Advanced Network Engine settings to use a lower value for the Minimum Fragment Size property, or set it to 0 to turn off this inspection. (See "Advanced Network Engine Options" in "Network engine settings" on page 725.)</p>
111	Fragment Out Of Bounds	The offsets(s) specified in a fragmented packet sequence is outside the range of the maximum size of a datagram.
112	Fragment Offset Too Small	A fragmented packet was encountered, the size of the fragment was less than the size of a TCP packet (no data).
113	IPv6 Packet	An IPv6 Packet was encountered, and IPv6 blocking is enabled. See the "Block IPv6 on Agents and Appliances versions 9 and later" property in the Advanced Network Engine Options (see " Network engine settings " on page 725.)
114	Max Incoming Connections	The number of incoming connections has exceeded the maximum number of connections allowed. See the "Enable TCP stateful inspection" property in " TCP packet inspection " on page 967.
115	Max Outgoing Connections	The number of outgoing connections has exceeded the maximum number of connections allowed. See the "Enable TCP stateful inspection" property in " TCP packet inspection " on page 967.
116	Max SYN Sent	The number of half open connections from a single computer exceeds that specified in the firewall stateful configuration. See the "Limit the number of half-open connections from a single computer to" property in " TCP packet inspection " on page 967.
118	IP Version Unknown	An IP packet other than IPv4 or IPv6 was encountered.
119	Invalid Packet Info	
120	Internal Engine Error	Insufficient system memory. Add more system resources to fix this issue.
121	Unsolicited UDP	Incoming UDP packets that were not solicited by the computer are rejected.
122	Unsolicited ICMP	ICMP stateful has been enabled (in firewall stateful configuration) and an unsolicited packet that does not match any Force Allow rules was received.
123	Out Of Allowed Policy	The packet does not meet any of the Allow or Force Allow rules and so is implicitly denied.
124	Invalid Port Command	An invalid FTP port command was encountered in the FTP control channel data stream.
125	SYN Cookie Error	The SYN cookies protection mechanism encountered an error.

ID	Event	Notes
126	Invalid Data Offset	Invalid data offset parameter.
127	No IP Header	The packet IP header is invalid or incomplete.
128	Unreadable Ethernet Header	Data contained in this Ethernet frame is smaller than the Ethernet header.
129	Undefined	
130	Same Source and Destination IP	Source and destination IPs were identical.
131	Invalid TCP Header Length	
132	Unreadable Protocol Header	The packet contains an unreadable TCP, UDP or ICMP header.
133	Unreadable IPv4 Header	The packet contains an unreadable IPv4 header.
134	Unknown IP Version	Unrecognized IP version.
135	Invalid Adapter Configuration	An invalid adapter configuration has been received.
136	Overlapping Fragment	This packet fragment overlaps a previously sent fragment.
138	Packet on Closed Connection	A packet was received belonging to a connection already closed.
139	Dropped Retransmit	<p>The network engine detected a TCP Packet that overlaps with data already received on the same TCP connection but does not match the already-received data. (The network engine compares the packet data that was queued in the engine's connection buffer to the data in the packet that was re-transmitted.)</p> <p>The network engine reconstructs the sequenced data stream of each TCP connection it processes. The sequence number and length in the received packet specify a specific region in this data stream. The note field in the log indicates the location of the changed content in the TCP stream: prev-full, prev-part, next-full and next-part:</p> <ul style="list-style-type: none"> "prev-full" and "prev-part": The changed area is in the packet that immediately precedes the retransmitted packet in the sequenced data stream. "prev-full" indicates that the changed area is completely contained in the packet which immediately precedes the

ID	Event	Notes
		<p>retransmitted packet in the sequenced data stream. Otherwise, the note is "prev-part".</p> <ul style="list-style-type: none"> • "next-full" and "next-part": The changed area is in the packet that immediately follows the retransmitted packet in the sequenced data stream. "next-full" indicates that the changed area is completely contained in the packet that immediately follows the retransmitted packet in the sequenced data stream. Otherwise, the note is "next-part".
140	Undefined	
141	Out of Allowed Policy (Open Port)	
142	New Connection Initiated	
143	Invalid Checksum	
144	Invalid Hook Used	
145	IP Zero Payload	
146	IPv6 Source Is Multicast	
147	Invalid IPv6 Address	
148	IPv6 Fragment Too Small	
149	Invalid Transport Header Length	
150	Out of Memory	
151	Max TCP Connections	The maximum number of TCP connections has been exceeded. See "Event: Max TCP connections" on page 1397 .
152	Max UDP Connections	
200	Region Too Big	A region (edit region, uri etc) exceeded the maximum allowed buffering size (7570 bytes) without being closed. This is usually because the data does not conform to the protocol.
201	Insufficient Memory	The packet could not be processed properly because resources were exhausted. This can be because too many concurrent connections require buffering (max 2048) or matching resources (max 128) at the same time or because of excessive matches in a single IP packet (max 2048) or simply because the system is out of memory.

ID	Event	Notes
202	Maximum Edits Exceeded	The maximum number of edits (32) in a single region of a packet was exceeded.
203	Edit Too Large	Editing attempted to increase the size of the region above the maximum allowed size (8188 bytes).
204	Max Matches in Packet Exceeded	There are more than 2048 positions in the packet with pattern match occurrences. An error is returned at this limit and the connection is dropped because this usually indicates a garbage or evasive packet.
205	Engine Call Stack Too Deep	
206	Runtime Error	Runtime error.
207	Packet Read Error	Low level problem reading packet data.
257	Fail Open: Deny	Log the packet that should be dropped but not when Fail-Open feature is on and in Inline mode.
300	Unsupported Cipher	An unknown or unsupported cipher suite has been requested.
301	Error Generating Master Key(s)	Unable to derive the cryptographic keys, Mac secrets, and initialization vectors from the master secret.
302	Record Layer Message (not ready)	The SSL state engine has encountered an SSL record before initialization of the session.
303	Handshake Message (not ready)	The SSL state engine has encountered a handshake message after the handshake has been negotiated.
304	Out Of Order Handshake Message	A well formatted handshake message has been encountered out of sequence.
305	Memory Allocation Error	The packet could not be processed properly because resources were exhausted. This can be because too many concurrent connections require buffering (max 2048) or matching resources (max 128) at the same time or because of excessive matches in a single IP packet (max 2048) or simply because the system is out of memory.
306	Unsupported SSL Version	A client attempted to negotiate an SSL V2 session.
307	Error Decrypting Pre-master Key	Unable to un-wrap the pre-master secret from the ClientKeyExchange message.
308	Client Attempted to Rollback	A client attempted to rollback to an earlier version of the SSL protocol than that which was specified in the ClientHello message.
309	Renewal Error	An SSL session was being requested with a cached session key that could not be located.

ID	Event	Notes
310	Key Exchange Error	The server is attempting to establish an SSL session with temporarily generated key.
311	Maximum SSL Key Exchanges Exceeded	The maximum number of concurrent key exchange requests was exceeded.
312	Key Too Large	The master secret keys are larger than specified by the protocol identifier.
313	Invalid Parameters In Handshake	An invalid or unreasonable value was encountered while trying to decode the handshake protocol.
314	No Sessions Available	
315	Compression Method Unsupported	
316	Unsupported Application-Layer Protocol	An unknown or unsupported SSL Application-Layer Protocol has been requested.
385	Fail Open: Deny	Log the packet that should be dropped but not when Fail-Open feature is on and in Tap mode.
500	URI Path Depth Exceeded	Too many "/" separators. Max 100 path depth.
501	Invalid Traversal	Tried to use "../" above root.
502	Illegal Character in URI	Illegal character used in uri.
503	Incomplete UTF8 Sequence	URI ended in middle of utf8 sequence.
504	Invalid UTF8 encoding	Invalid or non-canonical encoding attempt.
505	Invalid Hex Encoding	%nn where nn are not hex digits.
506	URI Path Length Too Long	Path length is greater than 512 characters.
507	Invalid Use of Character	Use of disabled characters
508	Double Decoding Exploit	Double decoding exploit attempt (%25xx, %25%xxd, etc).
700	Invalid Base64 Content	Packet content that was expected to be encoded in Base64 format was not encoded correctly.
710	Corrupted	Packet content that was expected to be encoded in Base64 format was

ID	Event	Notes
	Deflate/GZIP Content	not encoded correctly.
711	Incomplete Deflate/GZIP Content	Incomplete Deflate/GZIP content
712	Deflate/GZIP Checksum Error	Deflate/GZIP checksum error.
713	Unsupported Deflate/GZIP Dictionary	Unsupported Deflate/GZIP dictionary.
714	Unsupported GZIP Header Format/Method	Unsupported GZIP header format or method.
801	Protocol Decoding Search Limit Exceeded	A protocol decoding rule defined a limit for a search or pdu object but the object was not found before the limit was reached.
802	Protocol Decoding Constraint Error	A protocol decoding rule decoded data that did not meet the protocol content constraints.
803	Protocol Decoding Engine Internal Error	
804	Protocol Decoding Structure Too Deep	A protocol decoding rule encountered a type definition and packet content that caused the maximum type nesting depth (16) to be exceeded.
805	Protocol Decoding Stack Error	A rule programming error attempted to cause recursion or use too many nested procedure calls.
806	Infinite Data Loop Error	
10002	Log Reason Reset with Zero Sequence	Multiple TCP Reset (RST) packets with zero sequence have been sent.

Intrusion prevention events

For general best practices related to events, see ["About Deep Security event logging" on page 1125](#).

To see the intrusion prevention events captured by Deep Security, go to **Events & Reports > Events > Intrusion Prevention Events**.

What information is displayed for intrusion prevention events?

These columns can be displayed on the Intrusion Prevention Events page. You can click **Columns** to select which columns are displayed in the table.

- **Time:** Time the event took place on the computer.
- **Computer:** The computer on which this event was logged. (If the computer has been removed, this entry will read "Unknown Computer".)
- **Reason:** The intrusion prevention rule associated with this event.
- **Tag(s):** Any tags attached with the event.
- **Application Type:** The application type associated with the intrusion prevention rule which caused this event.
- **Action:** What action the intrusion prevention rule took (Block or Reset). If the rule is in **Detect Only** mode, the action is prefaced with "Detect Only:").

Note: Intrusion prevention rules created before Deep Security 7.5 SP1 could also perform Insert, Replace, and Delete actions. These actions are no longer performed. If an older rule is triggered and attempts to perform those actions, the event will indicate that the rule was applied in detect-only mode.

- **Rank:** The ranking system provides a way to quantify the importance of intrusion prevention and firewall events. By assigning "asset values" to computers, and assigning "severity values" to intrusion prevention rules and firewall rules, the importance ("rank") of an event is calculated by multiplying the two values together. This allows you to sort events by rank when viewing intrusion prevention or firewall events.
- **Severity:** The intrusion prevention rule's severity value.
- **Direction:** The direction of the packet (incoming or outgoing)
- **Flow:** whether the packets(s) that triggered this event was travelling with ("Connection Flow") or against ("Reverse Flow") the direction of traffic being monitored by the intrusion prevention rule.
- **Interface:** The MAC address of the interface through which the packet was passing.
- **Frame Type:** The frame type of the packet in question. Possible values are "IPV4", "IPV6", "ARP", "REVARP", and "Other: XXXX" where XXXX represents the four digit hex code of the frame type.

- **Protocol:** Possible values are "ICMP", "ICMPV6", "IGMP", "GGP", "TCP", "PUP", "UDP", "IDP", "ND", "RAW", "TCP+UDP", AND "Other: nnn" where nnn represents a three digit decimal value.
- **Flags:** Flags set in the packet.
- **Source IP:** The packet's source IP.
- **Source MAC:** The packet's source MAC address.
- **Source Port:** The packet's source port.
- **Destination IP:** The packet's destination IP address.
- **Destination MAC:** The packet's destination MAC address.
- **Destination Port:** The packet's destination port.
- **Packet Size:** The size of the packet in bytes.
- **Repeat Count:** The number of times the event was sequentially repeated.
- **Time (microseconds):** Microsecond resolution for the time the event took place on the computer.
- **Event Origin:** The Deep Security component from which the event originated.

The following columns are also available. They display information for events that are triggered from containers on computers that are protected by Deep Security Agent 12 FR or newer:

- **Interface Type:** Container interface type.
- **Container Name:** Name of the container where the event occurred.
- **Container ID:** Container ID of the container where the event occurred.
- **Image Name:** Image name that was used to create the container where the event occurred.
- **RepoDigest:** A unique digest that identifies the container image.
- **Process Name:** Name of the process (from the container) that caused the event.

View additional Intrusion Prevention event information

When [exporting](#) Intrusion Prevention events, the exported data includes the fields listed above, as well as additional fields, which are not visible from the Deep Security Manager console. The single exception is the **Severity field**, which is not available in the CSV file.

- **Note:** Meaningful string for the event, such as CVE code.
- **End Time:** Time the packet was most recently seen.

- **Position In Buffer:** Position in packet.
- **Position In Stream:** Position of packet in TCP/IP stream.
- **Data Flags:** Refer to the table below for details on Data Flags values:

Code	Flag	Notes
0x01	dataTruncated	Indicates data could not be logged.
0x02	logOverflow	Logs overflowed after this entry.
0x04	suppressed	Logs threshold suppression occurred after this entry.
0x08	haveData	Packet Data is logged.
0x10	refData	DataId is logged. Packet payload is not logged in this event. The payload is only logged in the event with the 0x08 flag and the same Data Index.
0x20	haveRawPkt	Data is the complete, raw packet.

- **Data Index:** A unique ID for packet data (dataId). All records with the same dataId are from the same packet.
- **Data:** Payload of the packet.
- **Original IP (XFF):** Displays original IP address of the client. To obtain data for this field, enable the rule **1006450 - Enable X-Forwarded-For HTTP Header Logging**.

The following fields are also available. They display information for events that are triggered from containers on computers that are protected by Deep Security Agent 12 FR or newer:

- **Process ID:** Process ID reported by the container.
- **Thread ID:** Thread ID reported by the container.
- **Image ID:** The local ID of the container image.
- **Pod ID:** The Pod ID (if applicable).

List of all intrusion prevention events

ID	Event	Notes
200	Region Too Big	A region (edit region, uri etc) exceeded the maximum allowed buffering size (7570 bytes) without being closed. This is usually because the data does not conform to the protocol.
201	Insufficient Memory	The packet could not be processed properly because resources were exhausted. This can be because there are too many concurrent connections at the same time or simply because the system is out of memory.
202	Maximum Edits Exceeded	The maximum number of edits (32) in a single region of a packet was exceeded.
203	Edit Too Large	Editing attempted to increase the size of the region above the maximum allowed size (8188 bytes).

ID	Event	Notes
204	Max Matches in Packet Exceeded	There are more than 2048 positions in the packet with pattern match occurrences. An error is returned at this limit and the connection is dropped because this usually indicates a garbage or evasive packet.
205	Engine Call Stack Too Deep	
206	Runtime Error	Runtime error.
207	Packet Read Error	Low level problem reading packet data.
258	Fail Open: Reset	Log the connection that should be reset but not when Fail-Open feature is on and in Inline mode
300	Unsupported Cipher	An unknown or unsupported Cipher Suite has been requested.
301	Error Generating Master Key(s)	Unable to derive the cryptographic keys, Mac secrets, and initialization vectors from the master secret.
302	Record Layer Message (not ready)	The SSL state engine has encountered an SSL record before initialization of the session.
303	Handshake Message (not ready)	The SSL state engine has encountered a handshake message after the handshake has been negotiated.
304	Out Of Order Handshake Message	A well formatted handshake message has been encountered out of sequence.
305	Memory Allocation Error	The packet could not be processed properly because resources were exhausted. This can be because there are too many concurrent connections at the same time or simply because the system is out of memory.
306	Unsupported SSL Version	A client attempted to negotiate an SSL V2 session.
307	Error Decrypting Pre-master Key	Unable to un-wrap the pre-master secret from the ClientKeyExchange message.
308	Client Attempted to Rollback	A client attempted to rollback to an earlier version of the SSL protocol than that which was specified in the ClientHello message.
309	Renewal Error	An SSL session was being requested with a cached session key that could not be located.
310	Key Exchange Error	The server is attempting to establish an SSL session with temporarily generated key.
311	Maximum SSL Key Exchanges Exceeded	The maximum number of concurrent key exchange requests was exceeded.

ID	Event	Notes
312	Key Too Large	The master secret keys are larger than specified by the protocol identifier.
313	Invalid Parameters In Handshake	An invalid or unreasonable value was encountered while trying to decode the handshake protocol.
314	No Sessions Available	
315	Compression Method Unsupported	
316	Unsupported Application-Layer Protocol	An unknown or unsupported SSL Application-Layer Protocol has been requested.
386	Fail Open: Reset	Log the connection that should be reset but not when Fail-Open feature is on and in Tap mode.
500	URI Path Depth Exceeded	Too many "/" separators. Max 100 path depth.
501	Invalid Traversal	Tried to use "../" above root.
502	Illegal Character in URI	Illegal character used in uri.
503	Incomplete UTF8 Sequence	URI ended in middle of utf8 sequence.
504	Invalid UTF8 encoding	Invalid or non-canonical encoding attempt.
505	Invalid Hex Encoding	%nn where nn are not hex digits.
506	URI Path Length Too Long	Path length is greater than 512 characters.
507	Invalid Use of Character	Use of disabled characters
508	Double Decoding Exploit	Double decoding exploit attempt (%25xx, %25%xxd, etc).
700	Invalid Base64 Content	Packet content that was expected to be encoded in Base64 format was not encoded correctly.
710	Corrupted Deflate/GZIP Content	Packet content that was expected to be encoded in Base64 format was not encoded correctly.
711	Incomplete Deflate/GZIP Content	Incomplete Deflate/GZIP content
712	Deflate/GZIP	Deflate/GZIP checksum error.

ID	Event	Notes
	Checksum Error	
713	Unsupported Deflate/GZIP Dictionary	Unsupported Deflate/GZIP dictionary.
714	Unsupported GZIP Header Format/Method	Unsupported GZIP header format or method.
801	Protocol Decoding Search Limit Exceeded	A protocol decoding rule defined a limit for a search or pdu object but the object was not found before the limit was reached.
802	Protocol Decoding Constraint Error	A protocol decoding rule decoded data that did not meet the protocol content constraints.
803	Protocol Decoding Engine Internal Error	
804	Protocol Decoding Structure Too Deep	A protocol decoding rule encountered a type definition and packet content that caused the maximum type nesting depth (16) to be exceeded.
805	Protocol Decoding Stack Error	A rule programming error attempted to cause recursion or use too many nested procedure calls.
806	Infinite Data Loop Error	

Integrity monitoring events

For general best practices related to events, see ["About Deep Security event logging" on page 1125](#).

To see the integrity monitoring events captured by Deep Security, go to **Events & Reports > Events > Integrity Monitoring Events**.

What information is displayed for integrity monitoring events?

These columns can be displayed on the Integrity Monitoring Events page. You can click **Columns** to select which columns are displayed in the table.

- **Time:** Time the event took place on the computer.
- **Computer:** The computer on which this event was logged. (If the computer has been removed, this entry will read "Unknown Computer".)
- **Reason:** The integrity monitoring rule associated with this event.
- **Tag(s):** Event tags that are applied to this event.
- **Change:** The change detected by the integrity rule. Can be: Created, Updated, Deleted, or Renamed.
- **Rank:** The ranking system provides a way to quantify the importance of events. By assigning "asset values" to computers, and assigning "severity values" to rules, the importance ("rank") of an event is calculated by multiplying the two values together. This allows you to sort events by rank.
- **Severity:** The integrity monitoring rule's severity value
- **Type:** Type of entity from which the event originated
- **Key:** Path and file name or registry key from which the event originated
- **User:** User ID of the file owner
- **Process:** Process from which the event originated
- **Event Origin:** The Deep Security component from which the event originated

List of all integrity monitoring events

ID	Severity	Event	Notes
8000	Info	Full Baseline Created	Created when the agent has been requested to build a baseline or went from 0 integrity monitoring rules to n (causing the baseline to be built). This event includes information on the time taken to scan (ms), and number of entities catalogued.
8001	Info	Partial Baseline Created	Created when the agent had a security configuration where one or more integrity monitoring rules changed. This event includes information on the time taken to scan (ms), and number of entities catalogued.
8002	Info	Scan for Change Completed	Created when the agent is requested to do a full or partial on-demand scan. This event includes information on the time taken to scan (ms), and number of CHANGES catalogued. (Ongoing scans for changes based on the FileSystem Driver or the notify do not generate an 8002 event.)
8003	Error	Unknown Environment Variable in Integrity Monitoring Rule	Created when a rule uses a <code>\${env.EnvironmentVar}</code> and "EnvironmentVar" is not a known environment variable. This event includes the ID of the integrity monitoring rule containing the problem, the name of the integrity monitoring rule, and the name of the unknown environment variable.

ID	Severity	Event	Notes
8004	Error	Bad Base in Integrity Monitoring Rule	Created when a rule contains an invalid base directory or key. For example, specifying a FileSet with a base of "c:\foo\d:\bar" would generate this event, or the invalid value could be the result of environment variable substitution the yields a bad value. This event includes the ID of the integrity monitoring rule containing the problem, the name of the integrity monitoring rule, and the bad base value.
8005	Error	Unknown Entity in Integrity Monitoring Rule	Created when an unknown EntitySet is encountered in an integrity monitoring rule. This event includes the ID of the integrity monitoring rule containing the problem, the name of the integrity monitoring rule, and a comma-separated list of the unknown EntitySet names encountered.
8006	Error	Unsupported Entity in Integrity Monitoring Rule	Created when a known but unsupported EntitySet is encountered in an integrity monitoring rule. This event includes the ID of the integrity monitoring rule containing the problem, the name of the integrity monitoring rule, and a comma-separated list of the unsupported EntitySet names encountered. Some EntitySet types such as RegistryKeySet are platform-specific.
8007	Error	Unknown Feature in Integrity Monitoring Rule	Created when an unknown feature is encountered in an integrity monitoring rule. This event includes the ID of the integrity monitoring rule containing the problem, the name of the integrity monitoring rule, the type of entity set (for example, FileSet), and a comma-separated list of the unknown feature names encountered. Examples of valid feature values are "whereBaseInOtherSet", "status", and "executable".
8008	Error	Unsupported Feature in Integrity Monitoring Rule	Created when a known but unsupported feature is encountered in an integrity monitoring rule. This event includes the ID of the integrity monitoring rule containing the problem, the name of the integrity monitoring rule, the type of entity set (for example, FileSet), and a comma-separated list of the unsupported feature names encountered. Some feature values such as "status" (used for Windows service states) are platform-specific.
8009	Error	Unknown Attribute in Integrity Monitoring Rule	Created when an unknown attribute is encountered in an integrity monitoring rule. This event includes the ID of the integrity monitoring rule containing the problem, the name of the integrity monitoring rule, the type of entity set (for example, FileSet), and a comma-separated list of the unknown attribute names encountered. Examples of valid attribute values are "created", "lastModified" and "inodeNumber".
8010	Error	Unsupported Attribute in Integrity Monitoring Rule	Created when a known but unsupported attribute is encountered in an integrity monitoring rule. This event includes the ID of the integrity monitoring rule containing the problem, the name of the integrity monitoring rule, the type of entity set (for example, FileSet), and a comma-separated list of the unsupported attribute names encountered. Some attribute values such as "inodeNumber" are platform-specific.
8011	Error	Unknown	Created when an unknown EntitySet XML attribute is encountered

ID	Severity	Event	Notes
		Attribute in Entity Set in Integrity Monitoring Rule	in an integrity monitoring rule. This event includes the ID of the integrity monitoring rule containing the problem, the name of the integrity monitoring rule, the type of entity set (for example, FileSet), and a comma-separated list of the unknown EntitySet attribute names encountered. You would get this event if you wrote <FileSet dir="c:\foo"> instead of <FileSet base="c:\foo">
8012	Error	Unknown Registry String in Integrity Monitoring Rule	Created when a rule references a registry key that doesn't exist. This event includes the ID of the integrity monitoring rule containing the problem, the name of the integrity monitoring rule, and the name of the unknown registry string.
8013	Error	Invalid WQLSet was used. Namespace or WQL query was missing.	Indicates that the namespace is missing from a WQL query because an integrity rule XML is incorrectly formatted. This can occur only in an advanced case, with custom integrity rules that use and monitor WQL queries.
8014	Error	Invalid WQLSet was used. An unknown provider value was used.	
8015	Warning	Inapplicable Integrity Monitoring Rule	Can be caused by a number of reasons, such as platform mismatch, nonexistent target directories or files, or unsupported functionality.
8016	Warning	Suboptimal Integrity Rule Detected	
8050	Error	Regular expression could not be compiled. Invalid wildcard was used.	

Log inspection events

For general best practices related to events, see ["About Deep Security event logging" on page 1125](#).

To see the log inspection events captured by Deep Security, go to **Events & Reports > Events > Log Inspection Events**.

What information is displayed for log inspection events?

These columns can be displayed on the log inspection events page. You can click **Columns** to select which columns are displayed in the table.

- **Time:** Time the event took place on the computer.
- **Computer:** The computer on which this event was logged. (If the computer has been removed, this entry will read "Unknown Computer".)
- **Reason:** The log inspection rule associated with this event.
- **Tag(s):** Any tags attached with the event.
- **Description:** Description of the rule.
- **Rank:** The ranking system provides a way to quantify the importance of events. By assigning "asset values" to computers, and assigning "severity values" to log inspection rules, the importance ("rank") of an event is calculated by multiplying the two values together. This allows you to sort events by rank.
- **Severity:** The log inspection rule's severity value.
- **Groups:** Group that the rule belongs to.
- **Program Name:** Program name. This is obtained from the syslog header of the event.
- **Event:** The name of the event.
- **Location:** Where the log came from.
- **Source IP:** The packet's source IP.
- **Source Port:** The packet's source port.
- **Destination IP:** The packet's destination IP address.
- **Destination Port:** The packet's destination port.
- **Protocol:** Possible values are "ICMP", "ICMPV6", "IGMP", "GGP", "TCP", "PUP", "UDP", "IDP", "ND", "RAW", "TCP+UDP", AND "Other: nnn" where nnn represents a three digit decimal value.
- **Action:** The action taken within the event

- **Source User:** Originating user within the event.
- **Destination User:** Destination user within the event.
- **Event HostName:** Hostname of the event source.
- **ID:** Any ID decoded as the ID from the event.
- **Status:** The decoded status within the event.
- **Command:** The command being called within the event.
- **URL:** The URL within the event.
- **Data:** Any additional data extracted from the event.
- **System Name:** The system name within the event.
- **Rule Matched:** Rule number that was matched.
- **Event Origin:** The Deep Security component from which the event originated.

List of log inspection security events

Note: For system events related to log inspection, see "[System events](#)" on page 1298.

ID	Severity	Event
8100	Error	Log Inspection Engine Error
8101	Warning	Log Inspection Engine Warning
8102	Info	Log Inspection Engine Initialized

Web reputation events

For general best practices related to events, see "[About Deep Security event logging](#)" on page 1125.

To see the web reputation events captured by Deep Security, go to **Events & Reports > Events > Web Reputation Events**.

What information is displayed for web reputation events?

These columns can be displayed on the web reputation events page. You can click **Columns** to select which columns are displayed in the table.

- **Time:** Time the event took place on the computer.
- **Computer:** The computer on which this event was logged. (If the computer has been removed, this entry will read "Unknown Computer".)

- **URL:** The URL that triggered this event.
- **Tag(s):** Event tags associated with this event.
- **Risk:** What was the risk level of the URL that triggered the event ("Suspicious", "Highly Suspicious", "Dangerous", "Untested", or "Blocked by Administrator").
- **Rank:** Rank provides a way to quantify the importance of events. It is calculated by multiplying the asset value of the computer by the severity of the rule. (See "[Rank events to quantify their importance](#)" on page 1145.)
- **Event Origin:** Indicates from which part of the Deep Security system the event originated.

Add a URL to the list of allowed URLs

If you want to add the URL that triggered an event to the list of allowed URLs, right-click the event and select **Add to Allow List**. (To view or edit the **Allowed** and **Blocked** lists, go to the **Exceptions** tab on the main **Web Reputation** page.)

Troubleshoot common events, alerts, and errors

Why am I seeing firewall events when the firewall module is off?

If you have Intrusion Prevention or Web Reputation enabled, you may see some Firewall events because the Intrusion Prevention and Web Reputation modules leverage the Firewall's stateful configuration mechanism to perform inspections.

Troubleshoot event ID 771 "Contact by Unrecognized Client"

Event ID 771 **Contact by Unrecognized Client** appears on Deep Security Manager if a Deep Security Agent or Deep Security Virtual Appliance tries to connect to the manager, but the computer's name doesn't exist in the list of protected computers on **Computers**.

Common causes include:

- Cloned VMs or cloud instances if you haven't enabled **Reactivate cloned Agents**.
- Computers deleted from **Computers** *before* deactivating Deep Security Agent, if you haven't enabled **Reactivate unknown Agents**. The agent software continues to try to periodically connect to its manager, causing the event each time until either it is uninstalled, or you reactivate the computer.

- Interrupted sync of a connector such as vCenter, AWS, or Azure. For example, if a VMware ESXi host is not shut down gracefully due to a power failure, then the VM's information may not be correctly synchronized.

Solutions vary by the cause.

Uninstall Deep Security Agent

If you don't want to protect the unrecognized computer, you can prevent these events by deactivating or uninstalling the Deep Security Agent software. See ["Uninstall Deep Security" on page 1675](#).

Reactivate the computer or clone

If you want to protect the computer, activate it with Deep Security Manager. Re-activation re-establishes the agent's certificate so that the manager can authenticate it with the list on **Computers**, and recognize the computer. See ["Agent-initiated activation \(AIA\)" on page 1474](#).

Fix interrupted VMware connector synchronization

1. On Deep Security Manager, go to **Computers**.
2. Remove the vCenter connector.
3. On VMware vSphere, reset the Deep Security Virtual Appliance (DSVA).

This will clear the information in:

```
/var/opt/ds_agent/guests
```

4. Add the vCenter into the Deep Security Manager again.
5. Re-activate the VMs.

Troubleshoot "Smart Protection Server disconnected" errors

If you are using the anti-malware or web reputation modules, you may see either a "Smart Protection Server Disconnected for Smart Scan" or "Smart Protection Server Disconnected for Web Reputation" error in the Deep Security Manager console. To fix the error, try the following troubleshooting tips.

Check the error details

Double-click the error message to display more detailed information, including the URL that the server is trying to contact. The error may include:

- Timeout was reached
- Couldn't resolve hostname

From a command prompt, use nslookup to check whether the DNS name resolves to an IP address. If the URL doesn't resolve, then there is a DNS issue on the local server.

Use a telnet client to test connectivity to the URL on ports 80 and 443. If you can't connect, check that all of your firewalls, security groups, etc. are allowing outbound communication to the URL on those ports.

Is the issue on a Deep Security Virtual Appliance?

If the error is occurring for a Deep Security Virtual Appliance:

1. Check the virtual appliance's internet connectivity.
2. Make sure the virtual appliance has a bi-directional connection to the internet via port 80.
3. Make sure there is sufficient memory assigned to the virtual appliance. For details on memory requirements, see ["Deep Security Virtual Appliance sizing" on page 407](#).

Error: Activation Failed

Several events can trigger an "Activation Failed" alert:

- ["Protocol Error" below](#)
- ["Unable to resolve hostname" on the next page](#)
- ["No agent/appliance" on the next page](#)
- ["Blocked port" on the next page](#)
- ["Duplicate Computer" on page 1378](#)
- ["Endpoint behind proxy" on page 1378](#)
- ["Reinstallation required" on page 1378](#)

Protocol Error

This error typically occurs when you use Deep Security Manager to attempt to activate a Deep Security Agent and the manager is unable to communicate with the agent. The communication directionality that the agent uses determines the method that you should use to troubleshoot this error. (See ["Agent-manager communication" on page 1448](#).)

Agent-initiated communication

When the agent uses agent-initiated communication, you need to activate the agent from the agent computer. (See ["Activate Deep Security Agent" on page 1745.](#))

Tip: Ensure that the console allows agent-initiated activation by going to **Administration > System Settings > Agent** and selecting **Allow Agent-Initiated Activation**.

Bidirectional communication

Use the following troubleshooting steps when the error occurs and the agent uses bidirectional communication:

1. Ensure that the agent is installed on the computer and that the agent is running.
2. Ensure that the ports are open between the manager and the agent. (See ["Port numbers, URLs, and IP addresses" on page 410](#) and ["Create a firewall rule" on page 939.](#))

Unable to resolve hostname

The error: Activation Failed (Unable to resolve hostname) could be the result of an unresolvable hostname in DNS or of activating the agent from Deep Security Manager when you are not using agent-initiated activation.

If your agent is in bidirectional or manager-initiated mode, your hostname must be resolvable in DNS. Check the DNS on your Deep Security Manager to ensure it can resolve your hosts.

If you your computers are in cloud accounts, we recommend that you always use agent-initiated activation. To learn how to configure policy rules for agent-initiated communication and deploy agents using deployment scripts, see ["Activate and protect agents using agent-initiated activation and communication" on page 1460.](#)

No agent/appliance

This error message indicates that the agent software has not been installed on the computer that you would like to protect.

Review ["Get Deep Security Agent software" on page 497.](#)

Blocked port

If you are seeing 'Activation Failed' events with the following error messages in the `ds_agent.log`:

Trend Micro Deep Security On-Premise 20

- 2018-06-25 17:52:14.000000: [Error/1] | CHTTPServer::AcceptSSL (<IP>:<PORT>) - BIO_do_handshake() failed - peer closed connection. | http\HTTPServer.cpp:246:DsaCore::CHTTPServer::AcceptSSL | 1E80:1FEC:ActivateThread
- 2018-06-25 17:52:14.143355: [dsa.Heartbeat/5] | Unable to reach a manager. | .\dsa\Heartbeat.lua:149:(null) | 1E80:1FEC:ActivateThread
- 2018-06-25 17:52:14.000000: [Info/5] | AgentEvent 4012 | common\DomainPrivate.cpp:493:DsaCore::DomPrivateData::AgentEventWriteHaveLock | 1E80:1FEC:ActivateThread
- 2018-06-25 17:52:14.143355: [Cmd/5] | Respond() - sending status line of 'HTTP/1.1 400 OK' | http\HTTPServer.cpp:369:DsaCore::CHTTPServer::Respond | 1E80:1D7C:ConnectionHandlerPool_0011

...and the following messages in your packet capture software (pcap):

- [TCP Retransmission] <Ephemeral Port> -> 443 [SYN, ECN, CWR]
- [TCP Retransmission] <Ephemeral Port> -> 443 [SYN]

...it may be because you have blocked a port used by the Deep Security Agents and manager to establish communication. agent-manager communication ports could be any of the following:

Agent-manager communication type	Source / Port	Destination / Port
Agent-initiated communication	Deep Security Agent / Ephemeral port	Manager / 4119
Manager-initiated communication	Deep Security Manager / Ephemeral port	Agent / 4118

As you can see from the table above, [ephemeral ports](#) are used for the source port for outbound communication between agent and manager. If those are blocked, then the agent can't be activated and heartbeats won't work. The same problems arise if any of the destination ports are blocked.

To resolve this issue:

- Remove restrictions on client outbound ports (ephemeral) in your network configuration.
- Allow access to Deep Security Manager on port 4119.

- Allow inbound access to Deep Security Agent on port 4118 if you're using Manager-initiated communication.

For details on ports, see ["Port numbers, URLs, and IP addresses" on page 410](#).

Duplicate Computer

This error typically occurs when you activate a computer using a name that already exists, or a computer that is already active in a different connector.

To resolve this issue you can use one of the following methods:

- Remove one of the duplicate computers and reactivate the remaining computer if necessary.
- From the Deep Security Manager, go to **Administration > System Settings > Agents** and select your preferences for agent-initiated activation. If a computer with the same name already exists, there are options to re-activate the existing computer, activate a new computer with the same name, or not allow activation. For more details, see ["Agent-initiated activation \(AIA\)" on page 1474](#).

Endpoint behind proxy

If you are using a proxy, in the Deep Security Manager go to **Support > Deployment Scripts** and update the fields with your proxy, then reactivate the agent. For more information, see ["Use deployment scripts to add and protect computers" on page 1790](#).

Reinstallation required

If Deep Security Agent is not activating, you may need to ["Uninstall Deep Security Agent" on page 1676](#), then [reinstall Deep Security Agent](#).

Error: Agent version not supported

The error message "Agent version not supported" indicates that the agent version currently installed on the computer is not supported by the Deep Security Manager.

Although the unsupported agent will still protect the computer based on the last policy settings it received from the Deep Security Manager, we recommend that you upgrade the agent so that you can react quickly to the latest threats. For more information, see ["Upgrade Deep Security Agent" on page 1625](#).

Error: Anti-Malware Engine Offline

Note: A common cause for this error is having Secure Boot enabled without a public key enrolled. Before continuing, Secure Boot users should consider checking that a public key is properly enrolled as detailed in the following article: [Linux Secure Boot support for agents](#). If you encounter this error and do not want to use Secure Boot, you can simply disable it to bring the Anti-Malware Engine back online.

This error can occur for a variety of reasons. To resolve the issue, follow the instructions below for the mode of protection that is being used:

- ["Agent-based protection" below](#)
- ["Agentless protection" on page 1381](#)

For an overview of the Anti-Malware module, see ["About Anti-Malware" on page 798](#).

Agent-based protection

1. In the Deep Security Manager, check for other errors on the same machine. If errors exist, there could be other issues that are causing your Anti-Malware engine to be offline, such as communications or Deep Security Agent installation failure.
2. Check communications from the agent to the Deep Security Relay and the manager.
3. In the Deep Security Manager, view the details for the agent with the issue. Verify that the policy or setting for Anti-Malware is turned on, and that the configuration for each scan (real-time, manual, scheduled) is in place and active. (See ["Enable and configure anti-malware" on page 805](#).)
4. Deactivate and uninstall the agent before reinstalling and re-activating it. See ["Uninstall Deep Security" on page 1675](#) and ["Activate the agent" on page 538](#) for more information.
5. In the Deep Security Manager, go to the **Updates** section for that computer. Verify that the Security Updates are present and current. If not, click **Download Security Updates** to initiate an update.
6. Check if there are conflicts with another anti-virus product, such as OfficeScan. If conflicts exist, uninstall the other product and Deep Security Agent, reboot, and reinstall the Deep Security Agent. To remove OfficeScan, see [Uninstalling clients or agents in OfficeScan \(OSCE\)](#).

If your agent is on Windows:

1. Make sure the following services are running:
 - Trend Micro Deep Security Agent
 - Trend Micro Solution Platform
2. Check that all the anti-malware related drivers are running properly by running the following commands:

For all versions of Deep Security Agent:

- `# sc query AMSP`

For Deep Security Agent 12.5 or earlier, also check:

- `# sc query tmcomm`
- `# sc query tmactmon`
- `# sc query tmevtmgr`

If a driver is not running, restart the Trend Micro services. If it is still not running, continue with the steps below.

3. Verify the installation method. Only install the MSI, not the zip file.
4. The agent might need to be manually removed and reinstalled. For more information, see [Manually uninstalling Deep Security Agent, Relay, and Notifier from Windows](#)
5. The installed Comodo certificate could be the cause of the issue. To resolve the issue, see ["Anti-Malware Driver offline" status occurs due to Comodo certificate issue](#).

If your agent is on Linux:

1. To check that the agent is running, enter the following command in the command line:
 - `service ds_agent status`
2. If you're using a Linux server, your kernel might not be supported. For more information, see ["Error: Module installation failed \(Linux\)" on page 1391](#).

If the problem is still unresolved after following these instructions, create a diagnostic package and contact support. For more information, see ["Create a diagnostic package and logs" on page 1951](#).

Agentless protection

1. In the Deep Security Manager, verify synchronization to vCenter and NSX. Under the **Computers** section, right click on your vCenter and go to **Properties**. Click **Test Connection**. Then click on the NSX tab and test the connection. Click **Add/Update Certificate** in case the certificate has changed.
2. Log into the NSX manager and verify that it is synching to vCenter properly.
3. Log into your vSphere client and go to **Network & Security > Installation > Service Deployments**. Check for errors with Trend Micro Deep Security and Guest Introspection, and resolve any that are found.
4. In vSphere client, go to **Network & Security > Service Composer**. Verify that the security policy is assigned to the appropriate security group.
5. Verify that your VMware tools are compatible with Deep Security. For more information, see [VMware Tools 10.x Interoperability Issues with Deep Security](#).
6. Verify that the File Introspection Driver (vsepfilt) is installed and running on the target VM. As an admin, run `sc query vsepfilt` at the command prompt.
7. All instances and virtual machines deployed from a catalog or vApp template from vCloud Director are given the same BIOS UUID. Deep Security distinguishes different VMs by their BIOS UUID, so a duplicate value in the vCenter causes an Anti-Malware Engine Offline error. To resolve the issue, see [VM BIOS UUIDs are not unique when virtual machines are deployed from vApp templates \(2002506\)](#).
8. If the problem is still unresolved, open a case with support with the following information:
 - Diagnostic package from each Deep Security Manager. For more information, see ["Create a diagnostic package and logs" on page 1951](#).
 - Diagnostic package from the Deep Security Virtual Appliance.
 - vCenter support bundle for the effected VMs.

Error: Device Control Engine Offline

This error can occur for a variety of reasons. To resolve the issue, follow the instructions below.

For an overview of the Device Control module, see ["Configure Device Control" on page 974](#).

1. In the Deep Security Manager console, check for other errors on the same machine. If errors exist, there could be other issues that are causing your Device Control engine to be offline, such as communications or agent installation failure.
2. Check communications from the agent to the Deep Security Relay and Deep Security Manager.

3. In the Deep Security Manager console, view the details for the agent with the issue. Verify that the policy or setting for Device Control is turned on.
4. Deactivate and uninstall the agent before reinstalling and re-activating it. See ["Uninstall Deep Security" on page 1675](#) and ["Activate the agent" on page 538](#) for more information.
5. In the Deep Security Manager console, go to the Updates section for that computer. Verify that the Security Updates are present and current. If not, click Download Security Updates to initiate an update.
6. Check if there are conflicts with another anti-virus product, such as OfficeScan. If conflicts exist, uninstall the other product and Deep Security Agent, reboot, and reinstall the Deep Security Agent. To remove OfficeScan, see [Uninstalling clients or agents in OfficeScan \(OSCE\)](#)

If your agent is on Windows

1. Make sure the following services are running:
 - Trend Micro Deep Security Agent
 - Trend Micro Solution Platform
2. Check that all the Device Control related drivers are running properly by running the following commands:

For all versions of Deep Security Agent:

- `# sc query AMSP`

If a driver is not running, restart the Trend Micro services. If it is still not running, continue with the following steps below.

3. Verify the installation method. Only install the MSI, not the zip file.
4. The agent might need to be manually removed and reinstalled. For more information, see [Manually uninstalling Deep Security Agent, Relay, and Notifier from Windows](#)

Error: Check Status Failed

You can check the status of the agent / appliance on a computer from the Deep Security Manager console. On the Computers page, right-click the computer and click **Actions > Check Status**.

If you get a "Check Status Failed" error, open the error message to see a more detailed description.

If description indicates a protocol error, it's usually caused by a communication issue. There are a few possible causes:

- Check whether the computer (or the policy assigned to the computer) is configured for agent-initiated communication or bidirectional communication. The "Check Status" operation will fail if you are using agent-initiated communication.
- Check that the Deep Security Manager can communicate with the agent. The manager should be able to reach the agent. See "[Port numbers, URLs, and IP addresses](#)" on [page 410](#).
- Check the resources on the agent computer. Lack of memory, CPU, or disk space can cause this error.

If the description indicates a SQLITE_IOERR_WRITE[778]: disk I/O error, there is likely a problem with the agent computer. The most common problem is that the disk is full or write-protected.

Error: Installation of Feature 'dpi' failed: Not available: Filter

The error message "Installation of Feature 'dpi' failed: Not available: Filter" indicates that your operating system kernel version is not supported by the network driver. You will typically get this message when installing Intrusion Prevention, Web Reputation, or Firewall because the Deep Security Agent installs a network driver at the same time in order to examine traffic. The same circumstances can cause **engine offline** alerts.

An update may be on its way. Trend Micro actively monitors a variety of operating system vendors for new kernel releases. After completing quality assurance tests, we will release an update with support for these kernels.

Your system will install the required support automatically when an update for your operating system kernel version becomes available.

Contact technical support (sign in Deep Security, and click **Support** in the top right-hand corner) to find out when support for your operating system kernel version will be released.

Additional information

This only affects Intrusion Prevention, Web Reputation, and Firewall. All other protection modules (Anti-Malware, Integrity Monitoring, and Log Inspection) will operate correctly.

To review supported operating system kernel versions, visit the [Deep Security 9.6 Supported Linux Kernels](#) page and look for your operating system distribution.

Error: Integrity Monitoring Engine Offline and other errors occur after activating a virtual machine

The following errors are displayed in Deep Security Manager when activating a virtual machine protected by Deep Security Virtual Appliance. These errors appear even when the activation is successful:

- Anti-Malware Engine Offline
- Rebuild Baseline Failure (Agent or Appliance error)
- Integrity Monitoring Engine Offline

The issue remains unresolved even when the following troubleshooting tasks are performed:

- Confirm that vSphere Endpoint is already installed.
- Confirm that VMware tools are installed and up to date.
- Confirm that VMCI and VSEPFLT drivers are installed and running on the VM.
- Synchronize vCenter on the DSM console.
- Deactivate and reactivate the Deep Security Virtual Appliance.
- Deactivate and reactivate the particular VM with issue.
- Reinstall VMware tools.

These errors appear because the virtual machine is not running VMversion 7 or above. To resolve the issue, you need to [upgrade the VM to the latest hardware version](#).

Error: Interface out of sync

This error occurs when the network interface information (such as different MAC addresses) that the Deep Security Manager has stored in its database for the guest virtual machine (VM) is not the same as the interface information being reported by the Deep Security Virtual Appliance.

To determine the root cause of this issue, you need to find out where the information has become out of sync.

The first step is to check the error message from Deep Security Manager to determine which VM and which interface has the issue.

Check the interfaces on the VM

1. Log into the VM.
2. Open a command prompt.
3. Enter the command to display all network interfaces' information. For example, on Windows, enter: `ipconfig /all`
4. Verify all of the NICs and MAC addresses and make sure that the NICs have the correct driver and that they are working properly.

Check the VM's interface information in vCenter

Check the VM interface information from the Managed Object Reference (MoRef) in the vCenter Server.

1. Go to the virtual computer MOB at: `https://<VC_SERVER>/mob/?moid=<OBJECT_ID>`

For example, you might go to this URL: `https://192.168.100.100/mob/?moid=vm-1136&doPath=config`

where:

<VC_SERVER> is the FQDN or IP of the vCenter Server

=<OBJECT_ID> is the ID of the object you are looking up

For more information on accessing the VC MOB see [Looking up Managed Object Reference \(MoRef\) in vCenter Server](#).

2. Go to `Config > extraConfig["ethernet0.filter0....."] > hardware` to check all the NICs and MAC address.
3. Compare the MAC addresses with [the MAC in the VM's OS](#).

Check the vmx file and the VM's interface information in Deep Security Manager

1. Use the vCenter Server datastore browser to download the VM's vmx file.
2. Open the vmx file using a plain text editor such as Notepad.
3. Check the IPs, uuid.bios, and MAC addresses.

For example:

```
Check virtual computer UUID
- uuid.bios = "42 23 d6 5d f2 d5 22 41-87 41 86 83 ea 2f 23 ac"
Check EPSec Settings
- VFILE.globaloptions = "svmip=169.254.50.39 svmport=8888"
- scsi0:0.filters = "VFILE"
Check DvFilter Settings
- ethernet0.filter0.name = "dvfilter-dsa"
- ethernet0.filter0.onFailure = "failOpen"
- ethernet0.filter0.param0 = "4223d65d-f2d5-2241-8741-8683ea2f23ac"
- ethernet0.filter0.param2 = "1"
- ethernet0.filter0.param1 = "00:50:56:A3:02:D8"
```

4. Go to the Deep Security Manager dashboard, double-click the **VM > Interfaces**, and verify the IPs and MAC addresses.
5. Compare the IP and MAC address with the results from above.

Check the VM's interface information in the Deep Security Virtual Appliance

1. Use the vCenter Server datastore browser to download the specific vmx file of the virtual computer.
2. Open the vmx file using a plain text editor such as Notepad.
3. Check the uuid.bios value.
4. Log on to the Deep Security Virtual Appliance console and press **Alt + F2** to switch to command mode and then enter the Deep Security Virtual Appliance user name and password.
5. Run the following command to determine whether the VM's network interface was recognized by Deep Security Virtual Appliance. (Note: Replace \$uuid with your actual bios uuid.)

```
cd /var/opt/ds_agent/guests/$uuid
```

```
>/opt/ds_guest_agent/ratt if
```

6. Execute the **ifconfig -a** command to verify if the Deep Security Virtual Appliance NIC settings and IP are configured correctly.
7. Compare the IP and MAC address with the results from above.

Workaround Options

If any of the above items are out of sync then you need to fix this issue.

Option 1

When cloning an activated VM in Deep Security, you might receive the out-of-sync interface alert if you power on and activate the cloned computer. As a work around, clean the dvfilter settings before powering on the cloned computer.

- `ethernet0.filter0.name = "dvfilter-dsa"`
- `ethernet0.filter0.onFailure = "failOpen"`
- `ethernet0.filter0.param0 = "4223d65d-f2d5-2241-8741-8683ea2f23ac"`
- `ethernet0.filter0.param2 = "1"`
- `ethernet0.filter0.param1 = "00:50:56:A3:02:D8"`

Option 2

1. Suspend the VM and power it on again.
2. Restart the Deep Security Virtual Appliance.
3. Deactivate the VM and then activate it again.

Option 3

Use vMotion to move the VM to a protected ESXi host and then dismiss the warning message.

Note: The vCenter must be connected to the Deep Security Manager all the time. Otherwise, the out-of-sync interface issue will happen repeatedly.

Further Troubleshooting

1. Provide the results of the step from above where you [verified the IP and MAC Addresses](#) in "Check the VM's interface information in the Deep Security Virtual Appliance " on the [previous page](#)
2. Get the rattif.txt file from the step from above where you [verified that the VM's interface was recognized by Deep Security Virtual Appliance](#).
3. Get the output from the following commands:

```
$ ls -alR > /home/dsva/ls.txt
$ netstat -an > /home/dsva/netstat.txt
$ ps auxww > /home/dsva/ps.txt
$ lsof > /home/dsva/lsof.txt
$ ifconfig -a > /home/dsva/ifconfig.txt
$ cp /var/log/syslog /home/dsva/syslog.txt
```

4. Get the [diagnostic packages for the Deep Security Manager, Deep Security Agent, and the Deep Security Virtual Appliance](#).
5. Collect the following files and send them to [Trend Micro Technical Support](#).
 - rattif.txt
 - ls.txt
 - netstat.txt
 - ps.txt
 - lsof.txt
 - ifconfig.txt
 - syslog.txt

If you cannot find the MAC address of the virtual computer from the output of the `ratt if` command, then use the following workaround:

1. Deploy a virtual computer from a template in vCenter.
2. Delete the existing NIC.
3. Power on this virtual computer but there is no need to log on.
4. Power off this virtual computer.
5. Add a new NIC.
6. Power on the virtual computer.

Error: Intrusion Prevention Rule Compilation Failed

This error can occur for a variety of reasons. Perform the following to confirm that the error is legitimate:

Resend the policy:

1. On the Deep Security Manager, click **Computers**.
2. Right-click the computer where the error occurred.
3. Go to **Actions > Send Policy**.

Verify status:

1. On the Deep Security Manager, click **Computers**.
2. Right-click the computer where the error occurred.
3. Go to **Actions > Clear Warnings/Errors**.
4. Once the warnings and errors are cleared, go to **Actions > Check Status**.

If the error continues to occur after completing the preceding steps, troubleshoot the issue with the solutions using the following solutions:

- ["Apply Intrusion Prevention best practices" below](#)
- ["Manage rules" below](#)
- ["Unassign application types from a single port" on the next page](#)

If the error persists, contact technical support.

Apply Intrusion Prevention best practices

The Intrusion Prevention Rule Compilation Failed error can occur due to a lack of resources on the machine, such as space, memory, or CPU. To help resolve this issue, apply the best practices on ["Performance tips for intrusion prevention" on page 924](#).

Manage rules

The Intrusion Prevention Rule Compilation Failed error can occur when the number of assigned Intrusion Prevention rules exceeds the recommended count. You should not have more than 400 Intrusion Prevention rules on an endpoint. It is recommended to only apply the Intrusion Prevention rules that a [recommendation scan](#) suggests in order to avoid applying unnecessary rules. If you are applying Intrusion Prevention rules manually, apply them to the computer rather than the policy to avoid adding too many application types to a single port.

To resolve the issue, reduce the number of assigned rules, as follows:

1. Access the Intrusion Prevention rules depending on how you assigned them. Do either of the following:
 - At the computer level, go to the **Computers** tab, right-click the computer and select **Details**.
 - At the policy level, go to the **Policies** tab, right-click the policy and select **Details**.
2. Go to **Intrusion Prevention** and click **Scan for Recommendations**.
3. Once the scan is complete, click **Assign/Unassign**. At the top of the window, filter the rules by **Recommended for Unassignment**.
4. To unassign a rule, select the check box next to the rule name. Alternatively, to unassign several rules at once use the Shift or Control keys to select the rules.

5. Right-click the rule or selection of rules to be removed and go to **Unassign Rule(s) > From All Interfaces**, then click **OK**. Close the window.
6. On the **Computers** tab right-click the computer, and go to **Actions > Clear Warnings/Errors**. The Intrusion Prevention engine will automatically attempt a rule compilation. The duration of the process will depend on the heartbeat interval and communication settings between Deep Security Manager and Agent.

Tip: If you applied Intrusion Prevention rules through a policy and are unsure which computers are affected, open the **Policy editor**¹ and go to **Overview > Computer(s) Using This Policy**.

Unassign application types from a single port

The Intrusion Prevention Rule Compilation Failed error can occur when a single port is assigned with too many application types. Currently, a port can only be assigned to sixteen application types.

To resolve the issue, remove an assigned application type from a port, as follows:

1. To determine which rule encountered the issue, double-click the error to open the **Event Viewer**.
2. Go to the **Computers** tab.
3. Right-click the computer with the misconfigured Intrusion Prevention rule and select **Details**.
4. Go to **Intrusion Prevention**.
5. Click **Assign/Unassign**. In the search bar, enter the name of the misconfigured rule.
6. Right-click the rule and select **Application Type Properties**.
7. Deselect the **Inherited** check box.
8. Delete the port and enter a new one.
9. Click **Apply** and **OK**.

Error: Log Inspection Rules Require Log Files

If a log inspection rule requires you to add the location of the files to be monitored, or if you add an unnecessary log inspection rule and the files do not exist on your machine, the following error will occur in the **Computer**² or **Policy editor**³:

¹To open the Policy editor, go to the Policies page and double-click the policy that you want to edit (or select the policy and click Details).

²To open the Computer editor, go to the Computers page and double-click the computer that you want to edit (or select the computer and click Details).

³To open the Policy editor, go to the Policies page and double-click the policy that you want to edit (or select the policy and click Details).

To resolve the error:

1. Click on the **Log Inspection Rules Require Log Files** error. A window will open with more information about the error. Under **Description**, the name of the rule causing the error will be listed.
2. In the Deep Security Manager, go to **Policies > Common Objects > Rules > Log Inspection Rules** and locate the rule that is causing the error.
3. Double-click the rule. The rule's properties window will appear.
4. Go to the **Configuration** tab.

If the file's location is required:

1. Enter the location under **Log Files to monitor** and click **Add**.
2. Click **OK**. Once the agent receives the policy, the error will clear.

If the files listed do not exist on the protected machine:

1. Go to the **Computer**¹ or **Policy editor**² > **Log Inspection**.
2. Click **Assign/Unassign**.
3. Locate the unnecessary rule and uncheck the checkbox.
4. Click **OK**. Once the agent receives the policy, the error will clear.

To prevent this error, run a recommendation scan for suggested rules:

1. On the Deep Security Manager, go to **Computers**.
2. Right-click the computer you'd like to scan and click **Actions > Scan for Recommendations**.
3. View the results on the **General** tab of the protection module in the **Computer**³ or **Policy editor**⁴.

Error: Module installation failed (Linux)

The error message "Module Installation Failed" indicates that your operating system's kernel version is not supported by the Deep Security network driver, or file system hook. These

¹To open the Computer editor, go to the Computers page and double-click the computer that you want to edit (or select the computer and click Details).

²To open the Policy editor, go to the Policies page and double-click the policy that you want to edit (or select the policy and click Details).

³To open the Computer editor, go to the Computers page and double-click the computer that you want to edit (or select the computer and click Details).

⁴To open the Policy editor, go to the Policies page and double-click the policy that you want to edit (or select the policy and click Details).

circumstances can cause **engine offline** alerts. Lack of a compatible network driver is the most common cause of this message.

When you apply intrusion prevention, web reputation, or firewall, the Deep Security Agent installs a network driver so it can examine traffic. Anti-malware and integrity monitoring install a file system hook module. This is required to monitor file system changes in real time. (Scheduled scans do not require the same file system hook.)

An update may be in progress. Trend Micro monitors many vendors for new kernel releases. After completing quality assurance tests, we release an update with support for these kernels. To ask when support for your kernel version will be supported, contact technical support. (When logged in, you can click **Support** in the top right corner.)

Your system will install the module support update automatically when it becomes available.

To view supported operating system kernel versions, see ["Linux kernel compatibility" on page 349](#).

Error: There are one or more application type conflicts on this computer

This error message appears in the DPI Events tab in Deep Security Manager when updating the Deep Security Agents:

There are one or more application type conflicts on this computer. One or more DPI rules associated with one application type are dependent on one or more DPI rules associated with another application type. The conflict exists because the two application types use different ports.

The conflicting application types are:

```
[A] "Web Application Tomcat" Ports: [80,8080,4119]
```

```
[B] "Web Server Common" Ports:  
[80,631,8080,7001,7777,7778,7779,7200,7501,8007,  
8004,4000,32000,5357,5358,9000]
```

```
[A] "Web Server Miscellaneous" Ports:  
[80,4000,7100,7101,7510,8043,8080,8081,8088,8300,8500,  
8800,9000,9060,19300,32000,3612,10001,8093,8094]
```

```
[B] "Web Server Common" Ports:  
[80,631,8080,7001,7777,7778,7779,7200,7501,8007,  
8004,4000,32000,5357,5358,9000]"
```

Resolution

To resolve the conflict, edit the port numbers used by application types B so that they include the port numbers used by application types A. The two application types (Web Application Tomcat and Web Server Miscellaneous) are both dependent on the application type Web Server Common. This is why the ports listed in the first two application types should also appear in the Web Server Common ports.

If you consolidate the port numbers for these three application types, the result is as follows:

```
80, 631, 3612, 4000, 4119, 5357, 5358, 7001, 7100, 7101, 7200, 7501, 7510, 7777, 7778, 7779,
8004, 8007, 8043, 8080, 8081, 8088, 8093, 8094, 8300, 8500, 8800, 9000, 9060, 10001, 19300, 32000
```

After adding this to the Web Server Common port list, you will see the following message in the Events tab: *The Application Type Port List Misconfiguration has been resolved.*

Consolidate ports

1. Log on to Deep Security Manager and go to **Policies > Rules > Intrusion Prevention Rules**.
2. Search for **Web Server Common** in the search box in the and double-click the Web Server Common application type.
3. Go to **General > Details > Application type > Edit > Web server common**.
4. Go to **General > Connection > Port** and click **Edit** to replace all of the ports with this consolidated entry: 80, 631, 3612, 4000, 4119, 5357, 5358, 7001, 7100, 7101, 7200, 7501, 7510, 7777, 7778, 7779, 8004, 8007, 8043, 8080, 8081, 8088, 8093, 8094, 8300, 8500, 8800, 9000, 9060, 10001, 19300, 32000
5. Click **OK**.

Disable the inherit option

It is also recommended that administrators disable the inherit option for DPI for a security profile. Any change you make to the application type will only affect this particular security profile.

1. Log on to Deep Security Manager and go to **Security Profiles**.
2. Double-click a security profile in the right pane.
3. Go to the **DPI** section and click to clear **Inherit**.
4. Click **OK**.

Check the IPS rule 1000128.

1. Right-click **Application Type Properties**.
2. Click to clear **Inherit**.
3. Verify that the current inherited port list contains the [listening port number for the Deep Security Manager's GUI](#). If not, add this port to the Web Server Common port group.
4. Click **Inherit**.

Error: Unable to connect to the cloud account

When adding an Amazon Cloud account, the error "Unable to connect to the cloud account" can occur. The cause can be:

- invalid key ID or secret
- incorrect permissions
- failed network connectivity

Your AWS account access key ID or secret access key is invalid

To resolve this:

Verify the security credentials that you entered.

The incorrect AWS IAM policy has been applied to the account being used by Deep Security

To resolve this:

Go to your AWS account and review the IAM policy for that account.

The AWS IAM policy must have these permissions:

- Effect: Allow
- AWS Service: Amazon EC2
- Select the following Actions:
 - DescribeImages
 - DescribeInstances
 - DescribeTags
- Amazon Resource Name (ARN) to: *

NAT, proxy, or firewall ports are not open, or settings are incorrect

This can occur in a few cases, including if you are deploying a new Deep Security Manager installation using the AMI on AWS Marketplace.

Your Deep Security Manager must be able to connect to the Internet, specifically to Amazon Cloud, on the [required port numbers](#).

To resolve this:

You may need to:

- configure NAT or port forwarding on a firewall or router between your AMI and the Internet
- get an external IP address for your AMI

The network connection must also be reliable. If it is intermittent, this error message may occur sometimes (but not every time).

Error: Unable to resolve instance hostname

The error message "Unable to Resolve Instance Hostname" may occur as a result of activating the Agent from Deep Security Manager when you are not using agent-initiated activation.

We recommend that you always use **Agent-Initiated Activation**. To learn how to configure policy rules for agent-initiated communication and deploy agents using deployment scripts, see ["Activate and protect agents using agent-initiated activation and communication" on page 1460](#).

Alert: Integrity Monitoring information collection has been delayed

This alert indicates that the rate at which integrity monitoring information is collected has been temporarily delayed. The delay is due to an increase in the volume of integrity monitoring data that is being transmitted from agents to Deep Security Manager. During this time the baseline and integrity monitoring event views may not be current for some computers.

This alert is automatically dismissed when the collection of integrity monitoring data is no longer delayed.

For more information about integrity monitoring, see ["Set up Integrity Monitoring" on page 977](#).

Alert: Manager Time Out of Sync

The system time on the Deep Security Manager operating system must be synchronized with the time on the database computer. This alert appears in the Alert Status widget of the manager console when the computer times are more than 30 seconds out of sync.

To synchronize the times, apply the following configurations:

- Configure the database and all manager nodes to use the same time zone.
- Ensure that the database and all manager nodes are synchronizing time to the same time source.
- If the manager runs on a Linux operating system, ensure the ntpd daemon is running.

Alert: The memory warning threshold of Manager Node has been exceeded

The **Memory Warning Threshold Exceeded** or **Memory Critical Threshold Exceeded** alerts appear in Deep Security to alert you that a host's memory usage has exceeded a certain amount. A warning alert indicates that 70% of the host's memory is used, and a critical alert indicates that usage has exceeded 85%.

To resolve this issue, determine whether there are processes unexpectedly consuming a large amount of memory:

- If the identified process **is not Deep Security Manager**, remove or eliminate the processes from the host. Deep Security Manager should run on a dedicated host computer.
- If the process **is Deep Security Manager**, increase the amount of the host memory. Refer to ["Sizing" on page 401](#) for guidelines.

Note: By default, the maximum heap size of Deep Security Manager is 4 GB. That means Deep Security Manager allocates a maximum 4 GB heap; however, the JVM allocates not only heap but also non-heap. Consequently, the maximum total memory size of the Deep Security Manager process will be larger than 4 GB.

Note: If the host is a VM, we strongly suggest that you reserve all guest memory for the VM.

Event: Max TCP connections

Deep Security is configured to allow a maximum number of TCP connections to protected computers. When the number of connections exceeds the maximum, network traffic is dropped and Max TCP Connections firewall events occur. To prevent dropped connections, increase the maximum allowed TCP connections on the computer where the Max TCP Connection event occurs.

Note: The intrusion protection module enables the network engine which enforces the allowed number of TCP connections.

1. In Deep Security Manager, click **Policies**.
2. Determine which policy to configure to affect the computer in question. See "[Policies, inheritance, and overrides](#)" on page 701.
3. To open the policy that you want to configure, double-click the policy.
4. In the left-hand pane, click **Settings** and then click the **Advanced** tab.
5. In the **Advanced Network Engine Settings** area, if Inherit is selected clear the checkbox to enable changes.
6. Increase the value of the **Maximum TCP Connections** property to 10000 or more, according to your needs.
7. Click **Save**.

Warning: Anti-Malware Engine has only Basic Functions

When new kernel versions are released, Trend Micro creates and releases kernel support packages for them. If your kernel version is not supported by the Linux agent, the Linux Anti-Malware Engine provides only basic protection to your computers. The Anti-Malware engine will return back to normal status from the basic function mode when your kernel version is supported.

Basic functions

Category	Feature name	Supported
Scan / Detection	Document exploit protection	✓
	Predictive machine learning	(1)
	Behavior monitoring	
	Spyware/Grayware	✓
	IntelliTrap	✓
	Scan compressed file	✓
	Smart scan	✓
	Connected threat defense	✓
Inclusion / Exclusion	Document exploit protection	✓
	Directories inclusion	✓
	File inclusion	✓
	Directories exclusion	✓
	File exclusion	✓
	File extension exclusion	✓
	Process image file exclusion (2)	✓
Quarantine	Quarantine file	✓
	Restore file	✓
Container	Container protection	(3)

(1) Predictive machine learning: Even though this may occasionally work (if Trend Micro can get the process image path), it is not reliable and therefore not supported.

(2) **Process image file exclusion:** This is moved to user-mode match. This mode may have performance impact.

(3) **Container protection:** Trend Micro cannot protect runtime container workloads in this mode.

Reason IDs

In a case where partial functionality is in operation, to ensure that the Linux agent returns to full functionality, it is necessary to take other steps that depend on the reason ID. The reason ID is included in events forwarded to an external Syslog, SIEM server, or to Amazon SNS. It is also displayed in event description for Linux agent (either Anti-Malware Engine Offline or Anti-Malware Engine with Basic Functions).

- **Reason ID 7:** No driver is available for the particular kernel version causes a driver offline error. To resolve this: **Check if latest Kernel Support Package (KSP) is released for that particular kernel. File a case to request KSP support.**
- **Reason ID 11:** The Trend Micro public key--on the system when SecureBoot is enabled--is **missing**, so loading the driver failed, which caused a driver offline error. To resolve this: ["Configure Linux Secure Boot for agents" on page 504.](#)
- **Reason ID 12:** The Trend Micro public key--on the system when SecureBoot is enabled--is **expired**, so loading the driver failed, which caused a driver offline error. To resolve this: ["Configure Linux Secure Boot for agents" on page 504.](#)
- For **all other reason IDs:** ["Create a diagnostic package and logs" on page 1951](#) and contact support.

Reason ID	Event reason	Description
1	Unknown reason	The malware scan failed for an unknown reason.
2	Incomplete Anti-Malware installation	Incomplete installation of the Anti-Malware service has caused a driver offline error.
3	Failed process communication between DSA and AM service	The process communication between the Deep Security Agent and Anti-Malware service failed and had caused a driver offline error.
4	Timeout of restart	Windows Anti-Malware service (AMSP) restarted timeout (that is, the sign check process has hung).
5	Stopped Anti-	The Anti-Malware service has stopped unexpectedly and

Reason ID	Event reason	Description
	Malware service	has caused a driver offline error.
6	Failed sign check	A Windows files (binaries/DLL) sign check failed unexpectedly.
7	Unavailable kernel version	No driver is available for the particular kernel version and has caused a driver offline error.
8	Failed driver loading	Load driver (tmhook/bmhook) into kernel has failed and has caused a driver offline error.
9	Failed driver unloading	<p>Unloading a driver from kernel failed and has caused a driver offline error.</p> <p>Note: No such scenario is needed currently, therefore, Trend Micro never reports this code in DsspState on Linux platforms.</p>
10	Failed driver device opening	Opening a driver device file failed and has caused a driver offline error.
11	Missing machine owner key Trend Micro public key	Missing machine owner key Trend Micro public key on the system when SecureBoot is enabled results in a driver load failed and this has caused a driver offline error.
12	Expired machine owner key Trend Micro public key	The machine owner key Trend Micro public key on the system is expired when SecureBoot is enabled results in a driver load failed and this has caused a driver offline error.
13	Signed with unauthorized public key	The driver was signed with an unknown/unsupported public key.

Warning: Census, Good File Reputation, and Predictive Machine Learning Service Disconnected

The Census, Good File Reputation, and Predictive Machine Learning Services are security services hosted by the Trend Micro Smart Protection Network. They are necessary for the full

and successful operation of the Deep Security behavior monitoring, predictive machine learning, and process memory scan features.

The following table maps the services to features.

Service name	Required for these features
Global Census Service	behavior monitoring , predictive machine learning
Good File Reputation Service	behavior monitoring , predictive machine learning , process memory scans
Predictive Machine Learning Service	predictive machine learning

If you see the alert...

Census, Good File Reputation, and Predictive Machine Learning Service Disconnected

...there are a few causes:

- ["Cause 1: The agent or relay-enabled agent doesn't have Internet access"](#) below
- ["Cause 2: A proxy was enabled but not configured properly"](#) below

Cause 1: The agent or relay-enabled agent doesn't have Internet access

If your agent or relay-enabled agent doesn't have access to the Internet, then it can't reach these services.

Solutions:

- Check your firewall policies and ensure that the outbound HTTP and HTTPS ports (by default, 80 or 443) are open.
- If you are unable to open those ports, see ["Configure agents that have no internet access" on page 1453](#) for other solutions.

Cause 2: A proxy was enabled but not configured properly

The Census, Good File Reputation and Predictive Machine Learning Services can be accessed using a proxy.

To check whether a proxy was enabled and make sure it was configured properly:

1. Open the **Computer or Policy editor**¹.
2. On the left, click Settings.
3. In the main pane, click the General tab.
4. Find the heading titled, **Network Setting for Census, Good File Reputation Service, and Predictive Machine Learning**.
5. If a proxy was specified, click **Edit** and make sure its **Proxy Protocol, Address, Port** and optional **User Name** and **Password** are accurate.

Warning: Insufficient disk space

An "Insufficient Disk Space" warning indicates that the computer where the Deep Security Agent or Appliance is running is low on disk space and may not be able to store more events. If you open the warning to display its details, it will show you the location of the agent or appliance, how much free space is left, and how much is required by the agent or appliance.

To fix this issue, check the drive or file system that's affected and clear anything you can.

Note: The agent or appliance will continue to protect your instance even if the drive is out of space; however, it will stop recording events.

Tips

- Even though the warning is generated by the Deep Security Agent or Appliance, another program that shares the same file system could be causing the space issue.
- Deep Security Agent automatically truncates and rotates its log files during normal operation. (This truncation and rotation is not related to issues with low disk space.)
- Deep Security Agent will clean up its own log files, but not those of other applications.
- Deep Security Manager does not automatically clear the "Insufficient Disk Space" warnings, but you can manually clear them from Deep Security Manager.

Warning: Reconnaissance Detected

The reconnaissance scan detection feature serves as an early warning of a potential attack or intelligence gathering effort against a network.

¹You can change these settings for a policy or for a specific computer. To change the settings for a policy, go to the Policies page and double-click the policy that you want to edit (or select the policy and click Details). To change the settings for a computer, go to the Computers page and double-click the computer that you want to edit (or select the computer and click Details).

Types of reconnaissance scans

Deep Security can detect several types of reconnaissance scans:

- **Computer OS Fingerprint Probe:** The agent or appliance detects an attempt to discover the computer's OS.
- **Network or Port Scan:** The agent or appliance reports a network or port scan if it detects that a remote IP is visiting an abnormal ratio of IPs to ports. Normally, an agent or appliance computer will only see traffic destined for itself, so a port scan is the most common type of probe that will be detected. The statistical analysis method used in computer or port scan detection is derived from the "TAPS" algorithm proposed in the paper "Connectionless Port Scan Detection on the Backbone" presented at IPCCC in 2006.
- **TCP Null Scan:** The agent or appliance detects packages with no flags set.
- **TCP SYNFIN Scan:** The agent or appliance detects packets with only the SYN and FIN flags set.
- **TCP Xmas Scan:** The agent or appliance detects packets with only the FIN, URG, and PSH flags set or a value of 0xFF (every possible flag set).

Suggested actions

When you receive a Reconnaissance Detected alert, double-click it to display more detailed information, including the IP address that is performing the scan. Then, you can try one of these suggested actions:

- The alert may be caused by a scan that is not malicious. If the IP address listed in the alert is known to you and the traffic is okay, you can add the IP address to the reconnaissance allow list:
 - a. In the **Computer or Policy editor**¹, go to **Firewall > Reconnaissance**.
 - b. The **Do not perform detection on traffic coming from** list should contain a list name. If a list name hasn't already been specified, select one.
 - c. You can edit the list by going to **Policies > Common Objects > Lists > IP Lists**. Double-click the list you want to edit and add the IP address.

¹You can change these settings for a policy or for a specific computer. To change the settings for a policy, go to the Policies page and double-click the policy that you want to edit (or select the policy and click Details). To change the settings for a computer, go to the Computers page and double-click the computer that you want to edit (or select the computer and click Details).

- You can instruct the agents and appliances to block traffic from the source IP for a period of time. To set the number of minutes, open the **Computer or Policy editor**¹, go to **Firewall > Reconnaissance** and change the **Block Traffic** value for the appropriate scan type.
- You can use a firewall or Security Group to block the incoming IP address.

Note: Deep Security Manager does not automatically clear the "Reconnaissance Detected" alerts, but you can manually clear the issue from Deep Security Manager.

For more information on reconnaissance scans, see ["Firewall settings" on page 954](#).

Configure proxies

Configure proxies

You can configure proxies between various Trend Micro servers and services.

In this topic:

- ["Register a proxy in the manager" on the next page](#)
- ["Supported proxy protocols" on the next page](#)
- ["Connect to the Primary Security Update Source via proxy" on page 1406](#)
- ["Connect to Deep Security Relays via proxy" on page 1408](#)
- ["Connect to Deep Security Manager via proxy" on page 1407](#)
- ["Connect to Deep Security Software Updates, CSSS, and more via proxy" on page 1409](#)
- ["Connect to cloud accounts via proxy" on page 1410](#)
- ["Connect to Deep Discovery Analyzer via proxy" on page 1410](#)
- ["Connect to Apex Central via proxy" on page 1410](#)
- ["Connect to the Smart Protection Network via proxy" on page 1411](#)
- ["Connect to Workload Security via proxy" on page 1412](#)
- ["Remove a proxy " on page 1412](#)

¹You can change these settings for a policy or for a specific computer. To change the settings for a policy, go to the Policies page and double-click the policy that you want to edit (or select the policy and click Details). To change the settings for a computer, go to the Computers page and double-click the computer that you want to edit (or select the computer and click Details).

Register a proxy in the manager

1. In Deep Security Manager, go to **Administration > System Settings > Proxies**.
2. In the **Proxy Servers** area, click **New > New Proxy Server**.
3. In the **Name** and **Description** fields, enter a friendly name and description for your proxy.
4. For the **Proxy Protocol**, select either **HTTP**, **SOCKS4**, or **SOCKS5**. Not all protocols are supported by all components. See "[Supported proxy protocols](#)" below for details.
5. In the **Address** and **Port** fields, enter the IP address or URL of the proxy as well its port (by default 8080 or 80 for HTTP; 3128 for the Squid HTTP proxy; 443 for HTTPS; and 1080 for SOCKS 4 and 5).
6. Enable **Proxy requires authentication credentials** if you previously set up your HTTP or SOCKS 5 proxy to require authentication from connecting components. Enter those credentials in the **User Name** and **Password** fields.

Supported proxy protocols

The following table lists the proxy protocols supported by the Trend Micro services and clients. You need this information to register and configure a proxy through `dsa_control`.

Service	Origin (client)	HTTP Support	SOCKS4 Support	SOCKS5 Support
Deep Security Manager	Agents/Relays	Yes	No	No
Deep Security Relays	Agents/Relays	Yes	Yes	Yes
Deep Security Software Updates, Certified Safe Software Service (CSSS), News Updates, Product Registration and Licensing	Manager	Yes	No	No
Deep Security Protected Product Usage Data Collection	Manager	Yes	No	No
Cloud accounts (AWS, Azure, Google Cloud Platform, VMware vCloud)	Manager	Yes	No	No
Deep Discovery Analyzer	Manager	Yes	No	No
Apex Central (formerly "Control Manager")	Manager	Yes	No	No
Smart Protection Network - Census, Good File Reputation, and Predictive Machine Learning	Agents	Yes	No	No
Smart Protection Network - Global Smart Protection Service	Agents	Yes	No	No
Smart Protection Network - Smart Feedback	Manager	Yes	No	Yes

Connect to the Primary Security Update Source via proxy

You can connect your agents, appliances, and relays to your primary security update source via a proxy. By default, the [primary security update source](#) is the Trend Micro Update Server (also known as Active Update).

Note that the **agents and appliances**¹ only use the proxy if their assigned relay is not available and they have been [granted explicit permission to access the primary update source](#).

1. Make sure that you are using Deep Security Agent 10.0 or later, as connections through a proxy are not supported in earlier versions.
2. ["Register a proxy in the manager" on the previous page](#).
3. If you are setting the security update proxy for the default relay group, perform the following:
 - In Deep Security Manager, select the **Administration > System Settings > Proxies** tab.
 - In the **Proxy Server Use** area, change the **Primary Security Update Proxy used by Agents, Appliances, and Relays** setting to point to the new proxy.
4. If you are setting the security update proxy for a non-default relay group, perform the following:
 - In Deep Security Manager, select the **Administration > Updates > Relay Management** tab.
 - Select the target relay group. In the **Relay Group Properties** area, change the **Update Source Proxy** setting to point to the new proxy.
5. Click **Save**.
6. Restart the agents.

Note:

The proxy should not replace the TLS certificate used to communicate with the primary security update source, as this can cause the security update to fail.

¹The Deep Security Agent and Deep Security Virtual Appliance are the components that enforce the Deep Security policies that you have defined. Agents are deployed directly on a computer. Appliances are used in VMware vSphere environments to provide agentless protection. They are not available with Deep Security as a Service.

Connect to Deep Security Manager via proxy

Agents connect to their manager during agent activation and heartbeats. There are two ways to connect an agent to its manager via a proxy:

Connect an agent to the manager via a proxy using a deployment script

1. Make sure you are using Deep Security Agent 10.0 or later, as connections through a proxy are not supported in earlier versions.
 2. ["Register a proxy in the manager" on page 1405.](#)
 3. In the top right of Deep Security Manager, click **Support > Deployment Scripts**.
 4. From **Proxy to contact Deep Security Manager**, select a proxy.
 5. Copy the script or save it.
 6. Run the script on the computer. The script installs the agent and configures it to connect to the manager through the specified proxy.
-

Connect an agent to the manager via a proxy using `dsa_control`

On a Windows agent:

- Open a command prompt (`cmd.exe`) as Administrator and enter the following:

```
cd C:\Program Files\Trend Micro\Deep Security Agent\  
dsa_control -u myUserName:MTPassw0rd  
dsa_control -x dsm_proxy://squid.example.com:443
```

On a Linux agent:

- Enter the following:

```
/opt/ds_agent/dsa_control -u myUserName:MTPassw0rd  
/opt/ds_agent/dsa_control -x dsm_proxy://squid.example.com:443
```

Regardless of the agent platform:

- Make sure the proxy uses one of the ["Supported proxy protocols" on page 1405.](#)
 - For details on `dsa_control` and its `-u` and `-x` options, see ["dsa_control" on page 1731.](#)
-

- Repeat these commands on each agent that needs to connect through a proxy to the manager.
 - Run commands to update the agent's local configuration. No policy or configuration changes are made in the manager as a result of running these commands.
-

Connect to Deep Security Relays via proxy

Agents connect to their relay to obtain software and security updates. There are two ways to connect an agent to a relay via a proxy:

Connect an agent to relays via a proxy using a deployment script

1. Make sure you are using Deep Security Agent 10.0 or later, as connections through a proxy are not supported in earlier versions.
 2. ["Register a proxy in the manager" on page 1405](#)
 3. In the top right of Deep Security Manager, click **Support > Deployment Scripts**.
 4. From **Proxy to contact Relay(s)**, select a proxy.
 5. Copy the script or save it.
 6. Run the script on the computer. The script installs the agent and configures it to connect to the relay through the specified proxy.
-

Connect an agent to relays via a proxy using dsa_control

On a Windows agent:

- Open a command prompt (cmd.exe) as Administrator and enter the following commands:

```
cd C:\Program Files\Trend Micro\Deep Security Agent\  
dsa_control -w myUserName:MTPassw0rd  
dsa_control -y relay_proxy://squid.example.com:443
```

On a Linux agent:

- Enter the following:

```
/opt/ds_agent/dsa_control -w myUserName:MTPassw0rd
```

```
/opt/ds_agent/dsa_control -y relay_proxy://squid.example.com:443
```

Regardless of the agent platform:

- Make sure the proxy uses one of the ["Supported proxy protocols" on page 1405](#).
- For details on `dsa_control` and its `-w` and `-y` options, see ["dsa_control" on page 1731](#).
- Repeat these commands on each agent that needs to connect through a proxy to the manager.
- Run commands to update the agent's local configuration. No policy or configuration changes are made in the manager as a result of running these commands.

Connect to Deep Security Software Updates, CSSS, and more via proxy

You can connect your agents to the following Deep Security cloud-based servers and services via a proxy:

- Software Update server (also known as the Download Center)
 - Certified Safe Software Service (CSSS), which is a feature of the Integrity Monitoring module
 - News Update service
 - Product Registration service
 - Licensing service
 - Deep Security Protected Product Usage Data Collection service (also known as the Telemetry service)
1. ["Register a proxy in the manager" on page 1405](#).
 2. In Deep Security Manager, click **Administration** at the top.
 3. In the main pane, select the **Proxies** tab.
 4. Next to **(Software Updates, CSSS, News Updates, Product Registration and Licensing)**, select your proxy.

5. Click **Save**.
6. ["Restart the Deep Security Manager" on page 1694](#) and all manager nodes so that the CSSS proxy settings take effect.

Connect to cloud accounts via proxy

You can connect the manager to an AWS, Azure, or GCP cloud account via a proxy. For more on these accounts, see ["About adding AWS accounts" on page 640](#), ["Add a Microsoft Azure account to Deep Security" on page 665](#), and ["Add a Google Cloud Platform account" on page 677](#).

1. ["Register a proxy in the manager" on page 1405](#).
2. In Deep Security Manager, click **Administration** at the top.
3. In the main pane, select the **Proxies** tab.
4. Next to **Deep Security Manager (Cloud Accounts - HTTP Protocol Only)**, select your proxy.
5. Click **Save**.

Connect to Deep Discovery Analyzer via proxy

You can connect your manager to Deep Discovery Analyzer via a proxy. For more on Deep Discovery Analyzer, see ["Detect emerging threats using Threat Intelligence" on page 833](#).

1. ["Register a proxy in the manager" on page 1405](#).
2. In Deep Security Manager, click **Administration** at the top.
3. In the main pane, select the **Threat Intelligence** tab.
4. In the **Sandbox Analysis** section, select **Proxy** and then select your proxy from the list.
5. Click **Save**.

Connect to Apex Central via proxy

You can connect your manager to Apex Central via a proxy. For more on Apex Central, see ["Detect emerging threats using Threat Intelligence" on page 833](#).

1. ["Register a proxy in the manager" on page 1405](#).
2. In Deep Security Manager, click **Administration** at the top.
3. In the main pane, select the **Threat Intelligence** tab.
4. In the **Suspicious Objects List** section, select the **Proxy** check box and then in the list, select your proxy.
5. Click **Save**.

Connect to the Smart Protection Network via proxy

Use the following procedure to configure a proxy between agents and the following services in the Smart Protection Network - Global Census, Good File Reputation, Predictive Machine Learning, and the Smart Protection Network itself:

1. ["Register a proxy in the manager" on page 1405.](#)
2. In Deep Security Manager, click **Policies** at the top.
3. In the main pane, double-click the policy that you use to protect computers that are behind the proxy.
4. Set up a proxy to the Global Census, Good File Reputation, and Predictive Machine Learning Services as follows:
 - a. Click **Settings** on the left.
 - b. In the main pane, click the **General** tab.
 - c. In the main pane, look for the **Network Setting for Census and Good File Reputation Service, and Predictive Machine Learning** section.
 - d. If the **Inherited** check box is selected, the proxy settings are inherited from the parent policy. To change the settings for this policy or computer, clear the check box.
 - e. Select **When accessing Global Server, use proxy** and in the list, select your proxy, or select **New** to specify another proxy.
 - f. Save your settings.
5. Set up a proxy to the Smart Protection Network for use with Anti-Malware:
 - a. Click **Anti-Malware** on the left.
 - b. In the main pane, click the **Smart Protection** tab.
 - c. Under **Smart Protection Server for File Reputation Service**, if the **Inherited** check box is selected, the proxy settings are inherited from the parent policy. To change the settings for this policy or computer, clear the check box.
 - d. Select **Connect directly to Global Smart Protection Service**.
 - e. Select **When accessing Global Smart Protection Service, use proxy** and in the list, select your proxy or select **New** to specify another proxy.
 - f. Specify your proxy settings and click **OK**.
 - g. Save your settings.
6. Set up a proxy to the Smart Protection Network for use with Web Reputation:
 - a. Click **Web Reputation** on the left.
 - b. In the main pane, click the **Smart Protection** tab.
 - c. Under **Smart Protection Server for Web Reputation Service**, set up your proxy, the same way you did under **Anti-Malware** in a previous step.
 - d. With **Web Reputation** still selected on the left, click the **Advanced** tab.
 - e. In the **Ports** section, select a group of port numbers that includes your proxy's listening port number, and then click **Save**. For example, if you're using a Squid proxy server,

you would select the **Port List Squid Web Server**. If you don't see an appropriate group of port numbers, go to **Policies > Common Objects > Lists > Port Lists** and then click **New** to set up your ports.

f. Save your settings.

7. Send the new policy to your agents. See ["Send policy changes manually" on page 700](#).

Your agents now connect to the Smart Protection Network through a proxy.

Connect to Workload Security via proxy

You can connect Deep Security Manager to Trend Cloud One - Endpoint & Workload Security via a proxy. See ["Migrate from Deep Security to Workload Security" on page 1697](#) for details.

1. ["Register a proxy in the manager" on page 1405](#).
2. In Deep Security Manager, go to **Administration > Proxies**.
3. Next to **Trend Cloud One Workload Security Link (HTTP Protocol Only)**, select your proxy.
4. Click **Save**.

Remove a proxy

To remove a proxy between agent and manager, or agent and relay

- Redeploy agents using new deployment scripts that no longer contain proxy settings. For details, see ["Use deployment scripts to add and protect computers" on page 1790](#).

or

- Run the following `dsa_control` commands on the agents:

```
dsa_control -x ""
```

```
dsa_control -y ""
```

These commands remove the proxy settings from the agent's local configuration. No policy or configuration changes are made in the manager as a result of running these commands.

For details on `dsa_control` and its `-x` and `-y` options, see ["dsa_control" on page 1731](#).

To remove a proxy between any other components

Run through the instructions on connecting through a proxy, but complete them in reverse, so that you remove the proxy.

Proxy settings

You can configure proxies between various Trend Micro components. For details, see ["Configure proxies" on page 1404](#).

Proxy server use

To view and edit the list of available proxies, go to **Administration > System Settings > Proxies**.

- **Primary Security Update Proxy used by Agents, Appliances, and Relays:** For information on this setting, see ["Connect to the Primary Security Update Source via proxy" on page 1406](#).
- **Deep Security Manager (Software Updates, CSSS, News Updates, Product Registration and Licensing):** For information on this setting, see ["Connect to Deep Security Software Updates, CSSS, and more via proxy" on page 1409](#).
- **Deep Security Manager (Cloud Accounts - HTTP Protocol Only):** For information on this setting, see ["Connect to cloud accounts via proxy" on page 1410](#)

Configure relays

How relays work

[Relays](#) redistribute both software updates and security updates to your agents and virtual appliances to help your deployment perform well at scale. (Alternatively, software updates – but not security updates – can be [distributed by a local mirror web server](#).) Relays can:

- Reduce WAN bandwidth costs by reducing external update traffic
- Speed up update distribution in large scale deployments
- Provide update distribution redundancy

- Temporarily store Integrity Monitoring data and some other files during VMware vMotion of a protected computer

Update sources are different for relays and agents or virtual appliances, depending on their parent relay group and the type of update.

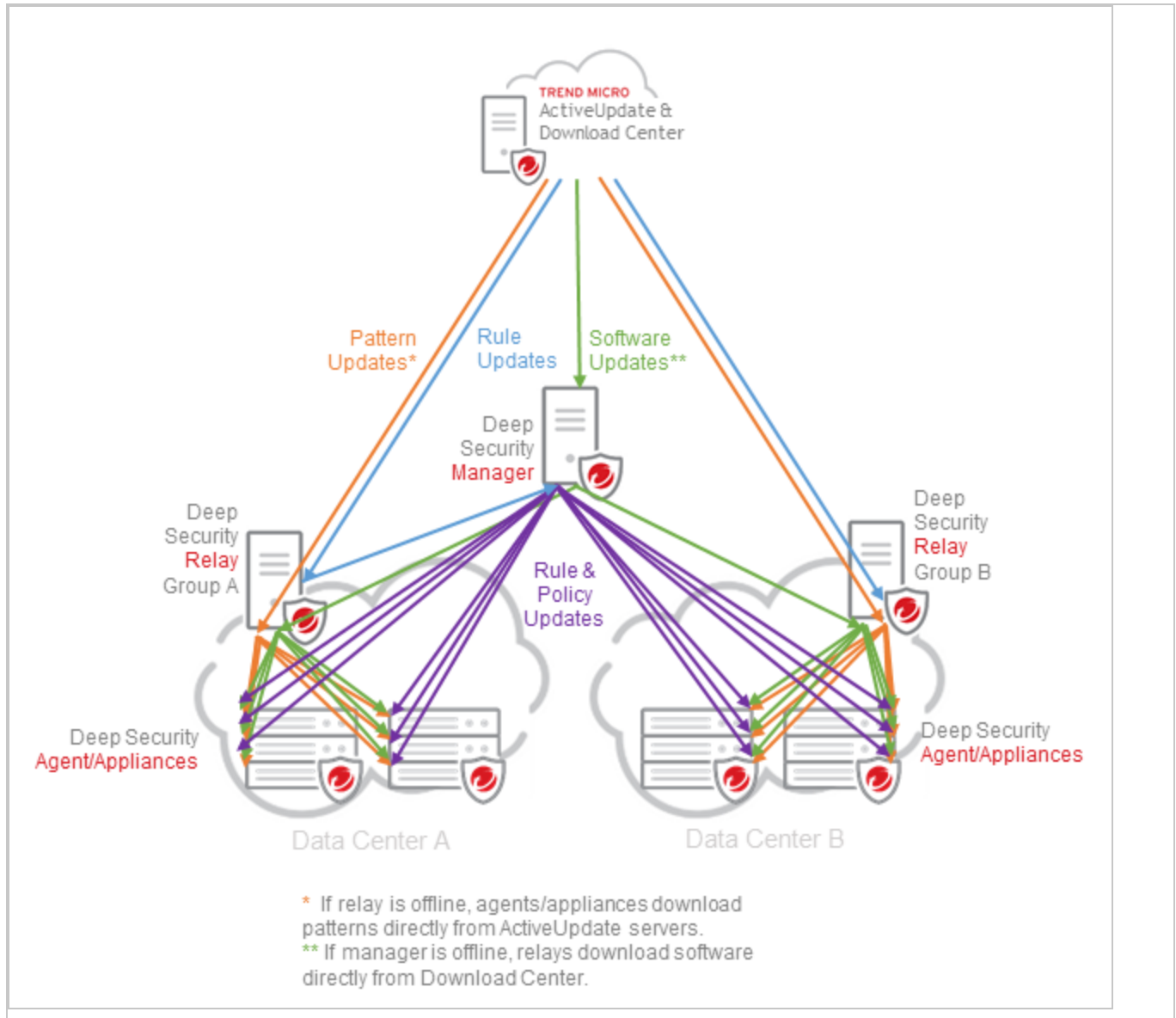

Agents get a randomly ordered list of relays for their assigned relay group. When an agent needs to download an update, they try the first relay. If there's no response, the agent tries the next in the list until it can successfully download the update. Because the list is random for each agent, this distributes update load evenly across relays in a group.

Note: If relays/agents and virtual appliances can't connect to their the manager/relay, they will use their [fallback update sources](#). For best performance, network connectivity between Deep Security components should be reliable.

Unlike other rule updates, Application Control rules are *not* downloaded from Trend Micro. However relays can similarly redistribute shared (not local) Application Control rulesets. See [Deploy application control rulesets via relays](#).

Relay hierarchy, cost, and performance

Relay groups can be organized in a hierarchy: one or more first-level ("parent") relay groups download updates *directly* from the manager and [Primary Security Update Source](#) (usually via their Internet/WAN connection), and then second-level ("child") relay groups download updates *indirectly* via the first-level group, and so on. If you put a child relay on each local network, then agent updates usually use the local network connection – not remote connections to the Internet. This saves external connection bandwidth (a typical performance bottleneck) and makes updates faster, especially for large deployments with many networks or data centers.

Performance and bandwidth usage can be affected by relay group hierarchy. Hierarchy can specify:

- **Update order** – Child relay sub-groups download from their parent group, which must finish its own download first. So a chain of sub-groups can be useful if you want a delay, so that all updates aren't at the exact same time.
- **Cost** – If large distances or regions are between your parent and child relay groups, it might be cheaper for them to download directly instead of via parent relay groups.
- **Speed** – If many or low-bandwidth subnets are between your parent and child relay groups, it might be faster for them to download directly or via a grandparent instead of via parent relay groups. However if too many relays do this, it will consume external connection bandwidth and eventually *decrease* speed.

Hierarchies are set up during relay group creation. For details, see ["Create relay groups" on page 1420](#).

Deploy additional relays

After [deploying your first Deep Security Relay](#), you should deploy at least one more for redundancy and load-balancing reasons. You may even need to deploy more depending on the

size and scope of your deployment.

When deploying relays, you need to do the following:

1. ["Plan the best number and location of relays" below](#)
2. ["Configure the update source" on page 1418](#)
3. ["Configure relays" on page 1420](#)

Warning: Too many relays on your network decrease performance – not improve it. A relay requires more system resources than an ordinary agent. Extra relays might be competing for bandwidth, too, instead of minimizing external connections. If required, you can convert a relay back to a regular Deep Security Agent. For more information, see ["Remove relay functionality from an agent" on page 1423](#).

Plan the best number and location of relays

The optimal number and placement of relays depends on the following factors:

- ["Geographic region and distance" on the next page](#)
- ["Network architecture and bandwidth limits" on the next page](#)
- ["Air-gapped environments" on page 1418](#)

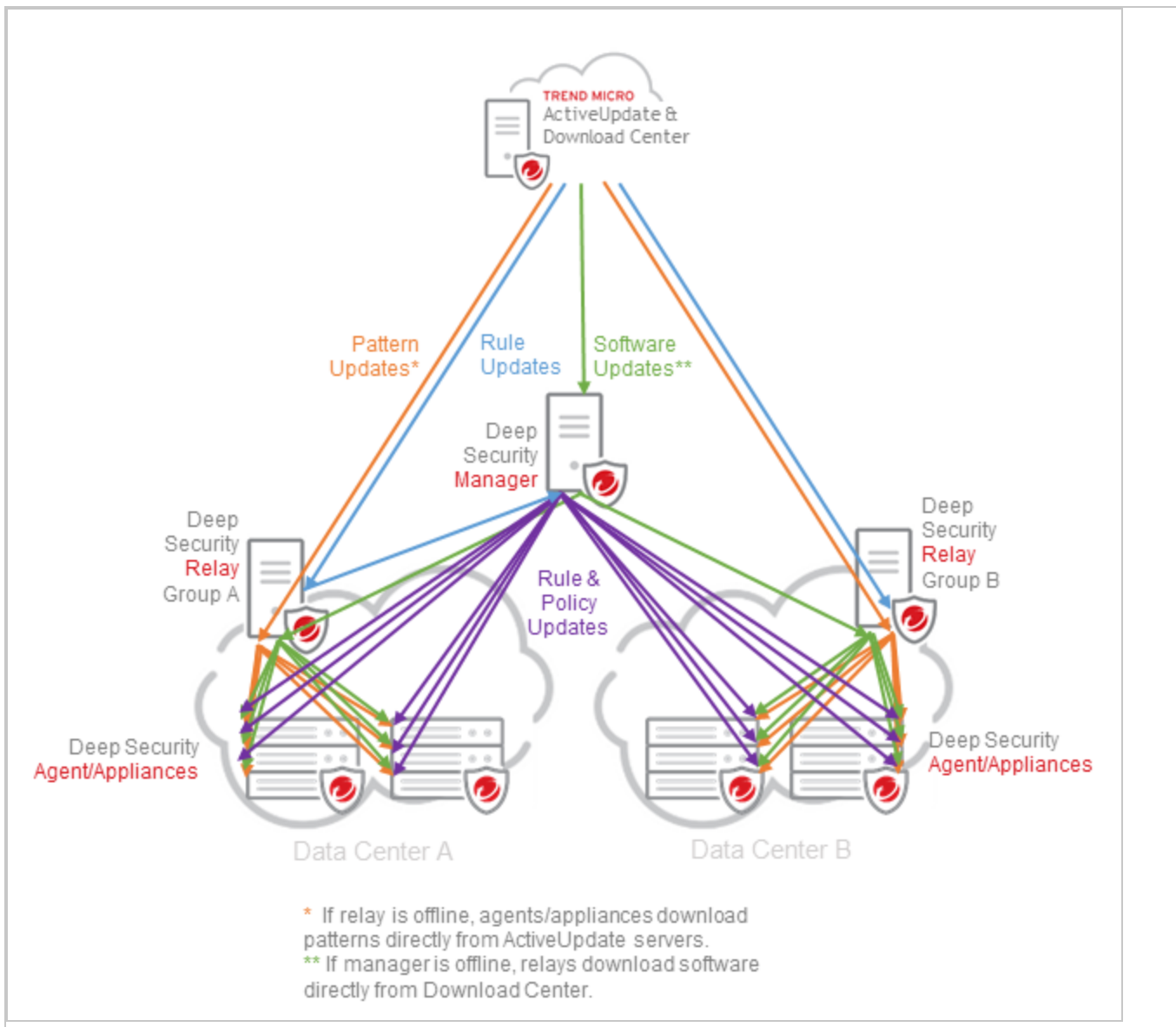

Geographic region and distance

Ideally, each geographic region should have its own [relay group](#) with at least two relays.

Agents should use local relays in the same geographic region. Long distance and network latency can slow down update redistribution. Downloading from other geographic regions can also increase network bandwidth and/or cloud costs.

Network architecture and bandwidth limits

Ideally, each network segment of agents or virtual appliances with limited bandwidth should have its own relay group with at least two relays.

Low bandwidth Internet/WAN connections, routers, firewalls, VPNs, VPCs, or proxy devices (which can all define a network segment) can be bottlenecks when large traffic volumes travel between the networks. Bottlenecks slow down update redistribution. Agents therefore usually should use local relays inside the same network segment – not relays outside on bottlenecked external networks.

For example, your relay group hierarchy could minimize Internet and internal network bandwidth usage. Only one parent relay group might use the Internet connection; subgroups would download from the parent, over their local network connection. Agents and virtual appliances would download from their local relay group.

Large scale deployments might have many agents and virtual appliances connect to each relay. This requires relays on more powerful, dedicated servers, as opposed to more relays on shared servers. For more information, see ["Deep Security Agent and Relay sizing" on page 405](#).

Air-gapped environments

Most deployments can connect to the Internet. But if your relays cannot connect to the Trend Micro ActiveUpdate server on the Internet because they are on an isolated network (an "air-gapped" deployment), then you need to do the following:

1. Add a separate relay in a demilitarized zone (DMZ) (which can connect to the Internet) to get the security updates.
2. Copy updates from the DMZ relay to your other, air-gapped relays.

For details, see ["Configure agents that have no internet access" on page 1453](#).

Configure the update source

Before setting up relays, perform the following to define the source of updates and when to bypass the usual [relay hierarchy](#) to get updates:

1. Go to **Administration > System Settings > Updates**.
2. Optionally, configure **Primary Security Update Source** and **Secondary Source**.

By default, the primary source is **Trend Micro Update Server** which is accessed via the Internet. Do not change the setting, unless your support provider has told you to configure **Other update source**. Alternative update source URLs must include "http://" or "https://".

3. Typically, agents and virtual appliances connect to a relay to get security updates when

Deep Security Manager tells them to. But if computers cannot always connect with the manager or relays (such as during scheduled maintenance times) *and* enough Internet/WAN bandwidth is available, you can select the following:

- **Allow Agents/Appliances to download security updates directly from Primary Security Update Source if Relays are not accessible**
- **Allow Agents/Appliances to download security updates when Deep Security Manager is not accessible**

Tip: If you protect laptops and portable computers, they might sometimes be far from support services. To avoid risk of a potentially problematic security update while they travel, deselect these options.

4. If you require security updates for older agents, select **Allow supported 8.0 and 9.0 Agents to be updated**. By default, Deep Security Manager does not download updates for Deep Security Agent 9.0 and earlier because most of these agents are no longer supported. For details on which older agents are still supported, see "[Deep Security LTS life cycle dates](#)" on page 109.
5. If you use multi-tenancy:
 - a. Typically, a relay only downloads and distributes patterns for the region (locale) in which Deep Security Manager was installed. This minimizes disk space usage. However, if you have tenants in other regions, select **Download Patterns for all Regions**.
 - b. Typically, the primary tenant shares its relays with other tenants. This simplifies setup for other tenants, as they do not need to set up their own relays. If you do not want to do this, deselect **Use the Primary Tenant Relay Group as my Default Relay Group (for unassigned Relays)**.

Note: If this option is deselected, when you click **Administration > Updates > Relay Groups**, then the relay group name will be **Default Relay Group** as opposed to **Primary Tenant Relay Group**.

6. If you would like Deep Security Manager to auto-import agent update builds to your local inventory, select **Automatically download updates to imported software**.

This setting imports the software to Deep Security Manager but does not automatically update your agent or appliance software. See "[Upgrade Deep Security Agent](#)" on page 1625 for more information.

- Typically, relays connect to Deep Security Manager to get software updates to redistribute. However, if relays cannot always connect with the manager (such as during scheduled maintenance times or when there is an enterprise firewall between the manager and relays), you can select **Allow Relays to download software updates from Trend Micro Download Center when Deep Security Manager is not accessible**. Relays will get software updates directly from the Download Center instead.

Tip: Hybrid cloud environments often have some agents and relays in a public cloud, while others (and the manager) are inside your private network. To avoid the risk of opening [port numbers](#) on your private network firewall, or manually copying software packages to your relays in the cloud, select this option.

- Configure **Alternate software update distribution server(s) to replace Deep Security Relays** to specify an alternative source for software updates, noting that security updates still need to come from a relay. Consider an alternative server if your relay has an elastic IP address, if you plan on [configuring your relays to only receive security updates](#) (not software updates), or if you want to [host software on a web server](#) for efficiency and availability reasons. Enter `https://<IP_or_hostname>:<port>/` replacing `<IP_or_hostname>:<port>` with one of the following:
 - The private network IP address and port of the relay that has an elastic IP address.
 - The web server and port where you plan to host the Deep Security software.

Configure relays

After determining the location and the number relays, as well as what update sources they should use, you can do the following:

- "[Create relay groups](#)" below
- "[Enable relays](#)" on the next page
- "[Assign agents to a relay group](#)" on page 1422
- "[Connect agents to a relay's private IP address](#)" on page 1423

Create relay groups

Relays must be organized into relay groups. The relay groups themselves can be further organized into [hierarchies](#).

If you installed a co-located relay during the Deep Security Manager installation, then it automatically created a default relay group. But if you need more groups for other locations (see "[Plan the best number and location of relays](#)" on page 1416), you can create more.

1. Go to **Administration > Updates > Relay Management** to open the **Relay Group Properties** pane.
2. Click **New Relay Group**.
3. Type a **Name** for the relay group.
4. In **Update Source**, select either [Primary Security Update Source](#) or, in case of a subgroup, the name of the parent relay group.

Note that the Default Relay Group is not included in the list of update sources, and therefore cannot be configured as a parent.

Consider selecting the update source with the best cost and speed. Even if a relay group is part of a hierarchy, sometimes it might be cheaper and faster to download updates from the Primary Security Update Source instead, not the parent relay group.

5. If this relay group must use a proxy when connecting to the Primary Security Update Source, select **Update Source Proxy**. For details, see "[Connect to the Primary Security Update Source via proxy](#)" on page 1406.

Unlike other relay groups, **Default Relay Group** uses **Primary Security Update Proxy used by Agents, Appliances, and Relays** setting available in the **Administration > System Settings > Proxies** tab.

If this relay group usually connects to a parent relay group, then the subgroup does not use the proxy unless the parent relay group is unavailable and it is configured to [fall back to using the Primary Security Update Source](#).

6. Under **Update Content**, select either **Security and software updates** or **Security updates only**. If you select **Security updates only**, you must configure an alternative software update source. For details, see "[Configure the update source](#)" on page 1418.

Tip: To minimize latency and external/Internet bandwidth usage, create a relay group for each geographic region and/or network segment.

Enable relays

1. Make sure the relay computer meets the requirements. See "[Deep Security Agent and Relay sizing](#)" on page 405 and "[Deep Security Relay requirements](#)" on page 333.
2. Make sure you allow inbound and outbound communication to and from the relay on the appropriate port numbers. See "[Deep Security port numbers](#)" on page 411.
3. If the relay must connect through a proxy, see "[Connect to the Primary Security Update Source via proxy](#)" on page 1406.

4. Deploy an agent on the chosen computer. See "[Get Deep Security Agent software](#)" on [page 497](#) and "[Install the agent](#)" on [page 515](#).
5. Enable the agent as a relay:
 - a. Log in to Deep Security Manager.
 - b. Click **Administration** at the top.
 - c. Click **Relay Management** in the left navigation pane.
 - d. If you are using Linux, before enabling the relay, create a user **nobody** and a relay group **nogroup**.
 - e. Select the relay group into which the relay will be placed. If a relay group does not exist, [create one](#). If you are using Linux, create a user **nobody** and a relay group **nogroup**.
 - f. Click **Add Relay**.
 - g. In **Available Computers**, select the agent you just deployed.
 - h. Click **Enable Relay and Add to Group**.

The agent is enabled as a relay and is displayed with a relay icon (.

Tip: To minimize latency and the Internet bandwidth usage, group together relays that are in the same geographic region and network segment.

Tip: You can use the search field to filter the list of computers.

Assign agents to a relay group

You must indicate which relay group each agent should use. Either assign each agent to a relay group manually, or set up an [event-based task](#) to assign new agents automatically.

1. Go to **Computers**.
2. Right-click the computer and select **Actions > Assign Relay Group**.

To assign multiple computers, Shift-click or Ctrl-click computers in the list, and then select **Actions > Assign Relay Group**.

3. Select the relay group that computer should use.

To minimize latency and external/Internet bandwidth usage, assign agents to relays that are in the same geographic region and/or network segment.

Connect agents to a relay's private IP address

If your relay has an elastic IP address, agents within an AWS VPC may not be able to reach the relay via that IP address. Instead, they must use the private IP address of the relay group.

1. Go to **Administration > System Settings**.
2. In the **System Settings** area, click the **Updates** tab.
3. Under **Software Updates**, in the window **Alternate software update distribution server(s) to replace Deep Security Relays**, type:

```
https://<IP>:<port>/
```

where `<IP>` is the private network IP address of the relay, and `<port>` is the [relay port number](#)

4. Click **Add**.
5. Click **Save**.

If your relay group's private IP changes, you must manually update this setting, as it does not update automatically.

Remove relay functionality from an agent

You might want to convert a relay back to being an ordinary Deep Security Agent if:

- Too many relays are causing communication delays
- Relays don't meet minimum system requirements to be a Deep Security Relay anymore

Warning: Deep Security Relays store data when a virtual machine (VM) protected by a Deep Security Virtual Appliance is being migrated by VMware vMotion. If your deployment uses vMotion, converting a relay back to a normal agent might cause the migrated VM to lose protection, and the virtual appliance to lose security events.

1. Go to **Administration > Updates > Relay Management**.
2. Click the arrow next to the relay group whose relay you want to convert back to an agent.
3. Click the computer.
4. Click **Remove Relay**.

The agent status will change to "Disabling" and the relay functionality will be removed from the agent.

It can take up to 15 minutes. If the agent is in the "Disabling" state for longer than this, you can deactivate and reactivate the agent to finish removing the relay feature.

Manage agents (protected computers)

Computer and agent statuses

On the **Computers** page in Deep Security Manager:

- The **Status** column displays the state of the computer's network connectivity and the state (in parentheses) of the agent or appliance providing protection, if present. The status column might also display system or agent events. See ["Status column - computer states" below](#) and ["Status column - agent or appliance states" on the next page](#)
- The **Task(s)** column displays the state of the tasks. See ["Task\(s\) column" on page 1426](#).

For a list of the events, see ["Agent events" on page 1292](#) and [" System events" on page 1298](#).

Also on this page:

- ["Computer errors" on page 1430](#)
- ["Protection module status" on page 1431](#)
- ["Perform other actions on your computers" on page 1432](#)
- ["Computers icons" on page 1436](#)
- ["Status information for different types of computers" on page 1438](#)

Status column - computer states

State	Description
Activated	The agent or appliance is activated. See "Perform other actions on your computers" on page 1432 .
Discovered	Computer has been added to the computers list via the discovery process. (See "Discover computers" on page 634 .)
Filter Driver Offline	The filter driver on the ESXi is offline.
Managed	An agent is present and activated, with no pending operations or errors.
Multiple Errors	Multiple errors have occurred on this computer. See the computer's system events for details.
Multiple Warnings	Multiple warnings are in effect on this computer. See the computer's system events for details.

State	Description
Prepared	The ESXi has been prepared for the installation of the virtual appliance. (The filter driver has been installed.)
Reactivation Required	The agent or appliance is installed and listening and is waiting to be reactivated a Deep Security Manager.
Unmanaged	The computer's agent is not managed by this Deep Security Manager because it hasn't been activated. Deep Security Manager can't communicate with the agent until you activate it.
Unprepared	The ESXi has not been prepared for the installation of the virtual appliance. (The Filter Driver has not been installed.)
Upgrade Recommended	A newer version of the agent or appliance is available. An software upgrade is recommended.
Upgrading Agent	The agent software on this computer is in the process of being upgraded to a newer version.

Status column - agent or appliance states

State	Description
Activated	The agent or appliance has been successfully activated and is ready to be managed by the Deep Security Manager.
Activation Required	An unactivated agent or appliance has been detected on the target machine. It must be activated before it can be managed by the Deep Security Manager.
Deactivation Required	The manager has attempted to activate an agent or appliance that has already been activated by another Deep Security Manager. The original Deep Security Manager must deactivate the agent or appliance before it can be activated by the new manager.
No Agent /Appliance	No agent or appliance was detected on the computer.
Offline	<p>The agent or appliance has not connected to the manager for the number of heartbeats specified on Computer or Policy editor¹ > Settings > General.</p> <p>This can occur when connectivity is interrupted by a network firewall or proxy, AWS security group, agent software update, or when a computer is powered down for repair.</p> <p>Verify that firewall settings allow the required port numbers, and that the computer is powered on.</p>
Online	The agent or appliance is online and operating as expected.

¹You can change these settings for a policy or for a specific computer. To change the settings for a policy, go to the Policies page and double-click the policy that you want to edit (or select the policy and click Details). To change the settings for a computer, go to the Computers page and double-click the computer that you want to edit (or select the computer and click Details).

State	Description
Unknown	No attempt has been made to determine whether an agent or appliance is present.
VM Paused	The virtual machine is in a "paused" state.
VM Stopped	The virtual machine is in a "stopped" state.

Task(s) column

State	Description
Activating	The manager is activating the agent or appliance.
Activating (Delayed)	The activation of the agent or appliance is delayed by the amount of time specified in the relevant event-based task.
Activation Pending	A command to activate the agent or appliance has been queued.
Agent Software Deployment Pending	An instruction to deploy the agent software is queued to be sent to the computer.
Agent Software Removal Pending	An instruction to remove the agent software is queued to be sent to the computer.
Application Control Inventory Scan In Progress	An application control inventory scan is being performed.
Application Control Inventory Scan Pending (Heartbeat)	An instruction to start an application control inventory scan will be sent from the manager during the next heartbeat.
Application Control Inventory Scan Pending (Offline)	The agent or appliance is currently offline. The manager will initiate an application control inventory scan when communication is reestablished.
Application Control Ruleset Update In Progress	The application control ruleset is being updated.
Application Control Ruleset Update Pending (Heartbeat)	An instruction to perform an application control ruleset update will be sent from the manager during the next heartbeat.
Application Control Ruleset Update Pending (Offline)	The agent or appliance is currently offline. The manager will initiate an application control ruleset update when communication is reestablished.
Baseline Rebuild In Progress	The Integrity Monitoring engine is currently rebuilding a system baseline.
Baseline Rebuild Paused	A baseline rebuild has been paused
Baseline Rebuild Pending	An instruction to rebuild a system baseline for Integrity Monitoring is queued to be sent.
Baseline Rebuild Pending (Offline)	The agent or appliance is currently offline. The Integrity Monitoring engine will rebuild a system baseline when communication between the manager and this computer is reestablished.

State	Description
Baseline Rebuild Queued	The instruction to perform a baseline rebuild is queued.
Checking Status	The agent state is being checked.
Deactivate Pending (Heartbeat)	A deactivate instruction will be sent from the manager during the next heartbeat.
Deactivating	The manager is deactivating the agent or appliance. This means that the agent or appliance is available for activation and management by another Deep Security Manager.
Deploying Agent Software	Agent software is being deployed on the computer.
File Backup Cancellation In Progress	A file backup is being canceled.
File Backup Cancellation Pending	An instruction to cancel a file backup is queued to be sent.
File Backup Cancellation Pending (Offline)	The agent or appliance is currently offline. The manager will initiate the cancellation of the file backup when communication is reestablished.
File Backup In Progress	A file backup is being performed.
File Backup Pending	An instruction to start a file backup is queued to be sent.
File Backup Pending (Offline)	The agent or appliance is currently offline. The manager will initiate a file backup when communication is reestablished.
File Backup Queued	The instruction to perform a file backup is queued.
Getting Events	The manager is retrieving events from the agent or appliance.
Integrity Scan In Progress	An Integrity Scan is currently in progress.
Integrity Scan Paused	An integrity scan has been paused.
Integrity Scan Pending	A command to start an integrity scan is queued to be sent.
Integrity Scan Pending (Offline)	The agent or appliance is currently offline. The manager will initiate an Integrity Scan when communication is reestablished.
Integrity Scan Queued	An instruction to start an integrity scan is queued to be sent.
Malware Manual Scan Cancellation In Progress	The instruction to cancel a manually-initiated Malware Scan has been sent.
Malware Manual Scan Cancellation Pending	The command to cancel a manually-initiated malware scan is queued to be sent.
Malware Manual Scan Cancellation	The appliance is offline. The instruction to cancel a manually-initiated Malware Scan will be sent when communication is reestablished.

State	Description
Pending (Offline)	
Malware Manual Scan In Progress	A manually-initiated Malware Scan is in progress.
Malware Manual Scan Paused	A manually-initiated Malware Scan has been paused.
Malware Manual Scan Pending	The instruction to perform a manually-initiated Malware Scan has not yet been sent.
Malware Manual Scan Pending (Offline)	The agent or appliance is offline. The instruction to start a manually-initiated Malware Scan will be sent when communication is reestablished.
Malware Manual Scan Queued	The instruction to perform a manually-initiated Malware Scan is queued.
Malware Scheduled Scan Cancellation In Progress	The instruction to cancel a scheduled Malware Scan has been sent.
Malware Scheduled Scan Cancellation Pending	The instruction to cancel a scheduled Malware Scan is queued to be sent.
Malware Scheduled Scan Cancellation Pending (Offline)	The agent or appliance is offline. The instruction to cancel a scheduled Malware Scan will be sent when communication is reestablished.
Malware Scheduled Scan In Progress	A scheduled Malware Scan is in progress.
Malware Scheduled Scan Paused	A scheduled Malware Scan has been paused.
Malware Scheduled Scan Pending	The command to cancel a scheduled malware scan has not yet been sent.
Malware Scheduled Scan Pending (Offline)	The agent or appliance is offline. The instruction to start a scheduled Malware Scan will be sent when communication is reestablished.
Malware Scheduled Scan Queued	The instruction to cancel a scheduled Malware Scan is queued.
Quick Malware Scan Cancellation In Progress	A quick malware scan is being canceled.
Quick Malware Scan Cancellation Pending	An instruction to cancel a quick malware scan is queued to be sent.
Quick Malware Scan Cancellation Pending (Offline)	The agent or appliance is currently offline. The manager will initiate the cancellation of a quick malware scan when communication is reestablished.
Quick Malware Scan In Progress	A quick malware scan is being performed.
Quick Malware Scan Paused	A quick malware scan has been paused.
Quick Malware	An instruction to start a quick malware scan is queued to be sent.

State	Description
Scan Pending	
Quick Malware Scan Pending (Offline)	The agent or appliance is currently offline. The manager will initiate a quick malware scan when communication is reestablished.
Quick Malware Scan Queued	The instruction to perform a quick malware scan is queued.
Removing Agent Software	The agent software is being removed from the computer.
Rollback of Security Update In Progress	A security update is being rolled back.
Rollback of Security Update Pending	An instruction to roll back a security update is queued to be sent.
Rollback of Security Update Pending (Heartbeat)	An instruction to roll back a security update will be sent from the manager during the next heartbeat.
Rollback of Security Update Pending (Offline)	The agent or appliance is currently offline. The manager will initiate a rollback of the security update when communication is reestablished.
Scan for Recommendations Pending (Heartbeat)	The manager will initiate a recommendation scan at the next heartbeat.
Scan for Recommendations Pending (Offline)	The agent or appliance is currently offline. The manager will initiate a recommendation scan when communication is reestablished.
Scan for Recommendations Pending (VM Offline)	The appliance is currently offline. The manager will initiate a recommendation scan when communication is reestablished.
Scanning for Open Ports	The manager is scanning the computer for open ports.
Scanning for Recommendations	A recommendation scan is underway.
Security Update In Progress	A security update is being performed.
Security Update Pending	An instruction to perform a security update is queued to be sent.
Security Update Pending (Heartbeat)	An instruction to perform a security update will be sent from the manager during the next heartbeat.
Security Update Pending (Offline)	The agent or appliance is currently offline. The manager will initiate a security update when communication is reestablished.
Sending Policy	A policy is being sent to the computer.
Update of Configuration Pending	An instruction to update the configuration to match the policy changes will be sent from the manager during the next heartbeat.

State	Description
(Heartbeat)	
Update of Configuration Pending (Offline)	The agent or appliance is currently offline. The manager will initiate the configuration update to match the policy changes when communication is reestablished.
Upgrading Software (In Progress)	A software upgrade is being performed.
Upgrading Software (Install Program Sent)	A software upgrade is being performed. The install program has been sent to the computer.
Upgrading Software (Pending)	An instruction to perform a software upgrade is queued to be sent.
Upgrading Software (Reboot to Complete Upgrade)	A software upgrade has been requested but will not be complete until the agent computer is rebooted. When the computer is in this state, it is still being protected by the older version of the Deep Security Agent.
Upgrading Software (Results Received)	A software upgrade is being performed. The results have been received.
Upgrading Software (Schedule)	A software upgrade will be performed once the computer's access schedule permits.

Computer errors

State	Description
Communication error	General network error.
No route to computer	Typically the computer cannot be reached because of a firewall between the manager and computer, or if a router between them is down.
Unable to resolve hostname	Unresolved socket address.
Activation required	An instruction was sent to the agent or appliance when it was not yet activated.
Unable to communicate with Agent /Appliance	Unable to communicate with agent or appliance.
Protocol Error	<p>Communication failure at the IP, TCP, or HTTP layer.</p> <p>For example, if the Deep Security Manager IP address is unreachable because the connection is being blocked by a firewall, router, or AWS security group, then it would cause a connection to fail. To resolve the error, verify that the activation port number is allowed and that a route exists.</p>
Deactivation	The agent or appliance is currently activated by another Deep Security

State	Description
Required	Manager.
No Agent /Appliance	No agent or appliance was detected on the target.
No valid software version	Indicates that no installer can be found for the platform and version requested.
Send software failed	There was an error in sending a binary package to the computer.
Internal error	Internal error. Please contact your support provider.
Duplicate Computer	Two computers in the Deep Security Manager's computers list share the same IP address.
VMware Tools Not Installed	VMware Tools (with the VMware Endpoint Driver) is not installed on a guest virtual machine. The VMware Endpoint Driver is required to provide Deep Security anti-malware and integrity monitoring protection. This error status will only be displayed when Deep Security is deployed in a VMware NSX environment.
Unresolved software change limit reached	Software changes detected on the file system exceeded the maximum amount. Application control will continue to enforce existing rules, but will not record any more changes, and it will stop displaying any of that computer's software changes. See "Reset Application Control after too much software change" on page 1118.

Protection module status

When you hover over a computer name on the **Computers** page, the **Preview** icon () is displayed. Click the icon to display the state of the computer's protection modules.

On and Off States:

State	Description
On	Module is configured in Deep Security Manager and is installed and operating on the Deep Security Agent.
Off	Module is either not configured in Deep Security Manager, not installed and operating on the Deep Security Agent, or both.
Unknown	Indicates an error with the protection modules.

Install state:

State	Description
Not Installed	The software package containing the module has been downloaded in Deep Security Manager, but the module has not been turned on in Deep Security Manager or installed on the agent.
Installation Pending	Module is configured in the manager but is not installed on the agent.
Installation in Progress	Module is being installed on the agent.
Installed	Module is installed on the agent. This state is only displayed when the state of the module is "Off". (If the state is "On", the module has been installed on the agent.)
Matching Module Plug-In Not Found	The version of the software package containing the module imported into the manager does not match the version reported by the agent.
Not Supported/Update Not Supported	A matching software package was found on the agent, but it does not contain a module supported by the platform. "Not Supported" or "Update Not Supported" is displayed depending on whether there is already a version of this module installed on the agent.

Perform other actions on your computers

On the **Computers** page, the **Actions** button provides several actions that you can perform on the selected computers.

Action	Description
Check Status	Checks the status of a computer without performing a scan or activation attempt.
Activate/Reactivate	Activates or reactivates the agent or appliance on the computer. See "Activate the agent" on page 538
Deactivate	You may want to transfer control of a computer from one Deep Security Manager installation to another. If so, the agent or appliance has to be deactivated and then activated again by the new manager.
Assign Policy	<p>Opens a window with a list that allows you to assign a policy to the computer. The name of the policy assigned to the computer will appear in the Policy column on the Computers page.</p> <p>Note: If you apply other settings to a computer (for example, adding additional Firewall Rules, or modifying Firewall Stateful Configuration settings), the name of the policy will be in bold,</p>

Action	Description
	indicating that the default settings have been changed.
Send Policy	When you use Deep Security Manager to change the configuration of an agent or appliance on a computer (apply a new intrusion prevention rule, change logging settings, etc.), the Deep Security Manager has to send the new information to the agent or appliance. This is a Send Policy instruction. Policy updates usually happen immediately but you can force an update by clicking Send Policy .
Download Security Update	Downloads the latest security update from the configured relay to the agent or appliance. See "Apply security updates" on page 1611 .
Rollback Security Update	Rolls back the latest security update for the agent or appliance.
Get Events	Override the normal event retrieval schedule (usually every heartbeat) and retrieve the event logs from the computer(s) now.
Clear Warnings/Errors	Use this command to clear all warnings and errors for the computer. This command is useful in these situations: <ul style="list-style-type: none"> • If the agent for the computer has been reset locally • If the computer has been removed from the network before you had a chance to deactivate or delete it from the list of computers
Upgrade Agent Software	To upgrade an agent or appliance, you first need to import a newer version of the agent or appliance software package into the Deep Security Manager (see "About upgrades" on page 1607).
Scan for Recommendations	Deep Security Manager can scan computers and then make recommendations for Security Rules. The results of a recommendation scan appear in the computer's Details window in the Rules pages. See "Manage and run recommendation scans" on page 705 .
Clear Recommendations	Clears rule recommendations resulting from a recommendation scan on this computer. Clearing also removes the computer from those

Action	Description
	<p>listed in an alert produced as a result of a recommendation scan.</p> <p>Note: This action will not un-assign any rules that were assigned because of past recommendations.</p>
Full Scan for Malware	<p>Performs a full malware scan on the selected computers. The actions taken by a full scan depend on the Malware Manual Scan Configuration in effect on this computer. See "Configure malware scans and exclusions" on page 808.</p>
Quick Scan for Malware	<p>Scans critical system areas for currently active threats. Quick Scan looks for currently-active malware but does not perform deep file scans to look for dormant or stored infected files. On larger drives, Quick Scan is significantly faster than a Full Scan.</p> <p>Note: Quick Scan is only available on-demand. You cannot schedule a Quick Scan as part of a scheduled task.</p>
Scan for Open Ports	<p>Performs a port scan on all selected computers and checks the agent installed on the computer to determine whether its state is either Deactivation Required, Activation Required, Agent Reactivate Required, or Online. The scan operation, by default, scans ports 1-1024. This range can be changed in Computer or Policy editor¹ > Settings > General.</p> <p>Note: The agent's listening port number for heartbeats is always scanned regardless of port range settings. When the Manager connects to communicate with the agent, it uses that port number. If communication direction is set to "Agent/Appliance Initiated" for a</p>

¹You can change these settings for a policy or for a specific computer. To change the settings for a policy, go to the Policies page and double-click the policy that you want to edit (or select the policy and click Details). To change the settings for a computer, go to the Computers page and double-click the computer that you want to edit (or select the computer and click Details).

Action	Description
	<p>computer (Computer or Policy editor¹ > Settings > General > Communication Direction), however, that port number will not be open. For a list of ports used, see "Deep Security port numbers" on page 411.</p> <p>N o t e :</p>

¹You can change these settings for a policy or for a specific computer. To change the settings for a policy, go to the Policies page and double-click the policy that you want to edit (or select the policy and click Details). To change the settings for a computer, go to the Computers page and double-click the computer that you want to edit (or select the computer and click Details).

Action	Description
	New computers on the network will not be detected. To find new computers, use the Discover tool.
Cancel Currently Executing Port Scans	If you have initiated a set of port scans to a large number of computers or over a large range of ports and the scan is taking too long, use the Cancel Currently Executing Port Scans option to cancel the scans.
Scan for integrity	Integrity Monitoring tracks changes to a computer's system and files. It does by creating a baseline and then performing periodic scans to compare the current state of the computer to the baseline. For more information see " Set up Integrity Monitoring " on page 977.
Rebuild Integrity Baseline	Rebuilds a baseline for Integrity Monitoring on this computer.
Assign Asset Value	Asset values allow you to sort computers and events by importance. The various security rules have a severity value. When rules are triggered on a computer, the severity values of the rules are multiplied by the asset value of the computer. This value is used to rank events in order of importance. See " Rank events to quantify their importance " on page 1145.
Assign a Relay Group	To select a relay group for this computer to download updates from, right-click the computer and choose Actions > Assign a Relay Group .

Computers icons



Ordinary computer



Deep Security Relay (a computer with a Relay-enabled Agent)













Deep Security Scanner (a computer with a Scanner-enabled agent)













Docker host (physical computer)









Azure virtual machine with Docker

-  Amazon EC2 with Docker
-  VMware virtual machine with Docker
-  Azure virtual machine with Scanner
-  Azure virtual machine with Scanner (started)
-  Azure virtual machine with Scanner (stopped)
-  Azure virtual machine with Scanner (suspended)
-  Amazon EC2 with Scanner
-  Amazon EC2 with Scanner (started)
-  Amazon EC2 with Scanner (stopped)
-  Amazon EC2 with Scanner (suspended)
-  Amazon WorkSpace (started)

Additional computer icons for vSphere environments:

-  ESXi server
-  Virtual computer (a virtual machine managed by VMware vCenter)
-  Virtual computer (started)
-  Virtual computer (stopped)
-  Virtual computer (suspended)
-  Virtual computer (with Relay enabled)
-  Virtual computer (started, Relay enabled)
-  Virtual computer (stopped, Relay enabled)
-  Virtual computer (suspended, Relay enabled)
-  Virtual computer (Scanner enabled)

-  Virtual computer (started, Scanner enabled)
-  Virtual computer (stopped, Scanner enabled)
-  Virtual computer (suspended, Scanner enabled)
-  Virtual Appliance
-  Virtual Appliance (started)
-  Virtual Appliance (stopped)
-  Virtual Appliance (suspended)

















Status information for different types of computers

The circular icon indicates the overall status for the agent or the module:

- Green: No issues
- Yellow: An issue has been found
- Red: A critical issue has been found
- Gray: Unable to find or to check for issues. It may be that a module has been turned off, or that even though the module has been turned on, there are no rules associated with the module and the module can therefore not report any result.

















Ordinary computer

The preview pane for an ordinary computer displays the presence of an agent, its status, and the status of the protection modules.

		Agent
		Managed (Online)
		On, Real Time
		On
		On, 41 rules
		On, Prevent, 193 rules
		On, no rules
		On, 5 rules
		Off, not supported

















Relay

The preview pane for a Deep Security relay-enabled agent displays its status, the number of security update components it has available for distribution, and the status of the protection modules provided by its embedded Deep Security agent.

		Agent	
		Managed (Online)	 Relay 192 components available
		On, Real Time	
		On	
		On, 41 rules	
		On, Prevent, 316 rules	
		On, 30 rules	
		On, 6 rules	
		Off, not supported	

















Deep Security Scanner

The preview pane for a Deep Security Scanner displays the presence of an agent or combined mode (agent and appliance), its status, the status of the protection modules, and the scanner status (SAP).

	 Agent	
	 Managed (Online)	 Scanner(SAP): On
 Anti-Malware	 On, Real Time	
 Web Reputation	 On	
 Firewall	 On, 41 rules	
 Intrusion Prevention	 On, Prevent, 316 rules	
 Integrity Monitoring	 On, 30 rules	
 Log Inspection	 On, 6 rules	
 Application Control	 Off, not supported	







Docker, Podman, and CRI-O hosts

The preview pane for a host displays the presence of an agent and its status, the status of the protection modules, and the host status.

	 Agent	
	 Managed (Online)	 Docker Host detected
 Anti-Malware	 On, Real Time	
 Web Reputation	 On	
 Firewall	 On, 16 rules	
 Intrusion Prevention	 On, Prevent, 145 rules	
 Integrity Monitoring	 On, 21 rules	
 Log Inspection	 On, 4 rules	
 Application Control	 Off, not supported	





ESXi server

The preview pane for an ESXi server displays its status and the version number of the ESXi software. In the **Guests** area are displayed the presence of a Deep Security Virtual Appliance, and the virtual machines running on this host.

 ESXi	Guests
 Managed	 bh-2012r2-1.matrix.local (bh-2012r2-1)
ESXi Version 6.0.0	 bh-rhel-71-64-2 (bh-rhel-7.1-64-2)
	 localhost (Guest Introspection (1))
	 localhost.localdom (Trend Micro Deep Security (











Virtual appliance







The preview pane for a Virtual Appliance displays its status and the version number of the Appliance. In the **Protected Guests On** area the protected virtual machines are displayed.

 Appliance	Protected Guests On  lab1-esx1a.matrix.local
 Managed (Online)	 bh-rhel-71-64-2 (bh-rhel-7.1-64-2)
Appliance Version 10.0.0.2074	

Virtual machine with agentless protection

The preview pane for a virtual machine displays whether it is being protected by a Virtual Appliance, an in-guest Agent, or both. It displays details about the components running on the virtual machine.

 Appliance	 ESXi lab1-esx1a.matrix.local
 Managed (Online)	 Appliance localhost.localdom (Trend Micro Deep Security (
 Anti-Malware	
 Web Reputation	
 Firewall	
 Intrusion Prevention	
 Integrity Monitoring	
 Log Inspection	

 Managed (Online)	
 On, Real Time	
 Off	
 On, 22 rules	
 On, Prevent, 595 rules	
 On, 28 rules	
 Not Supported	

Configure agent version control

Agent version control is a feature that gives you and your security operations team control over the specific versions of the Deep Security Agent that will be deployed when:

- using [deployment scripts](#)
- upgrading the agent through an [upgrade alert](#), button, check box or other widget in the manager (the exceptions are listed [in the FAQ](#))
- upgrading the agent through the [agent upgrade on activation](#) feature

This allows security operations teams who do not have control over Deep Security Manager's local inventory of agents or the relays the ability to declare exactly what agents will be used at any given time.

As new agents are released by Trend Micro, your security operations team can test them in controlled environments before changing the version control settings to expose the new agents to downstream applications teams in their production environment.

Topics:

- ["Set up agent version control" below](#)
- ["Use agent version control with URL requests" on page 1444](#)
- ["Agent version control FAQs" on page 1444](#)

Set up agent version control

1. Before you begin, [import the agent](#) versions you want to use.
2. Go to Deep Security Manager.
3. Click **Administration** at the top.
4. On the left, expand **Updates > Software > Agent Version Control**.

All the agent platforms appear in the main pane.

5. (Optional) Use the **Show/Hide Platforms** section on the right to restrict the agent platforms that are visible.
6. Make your agent version selections and click **Save**. Follow this guidance:

Note: Only agent versions 9.0 or later are displayed. For Solaris specifically, only versions 11.0 or later are displayed. If you want to deploy earlier agents, you'll have to

use the `agentVersion=` setting available in the deployment scripts. For details, see ["Use deployment scripts to add and protect computers" on page 1790](#).

Column	Description
PLATFORM	This column lists the platforms for which Deep Security Agent software is available.
VERSION CONTROL	<p>This column is where you select which version of the agent will be used by deployment scripts and so on. It has the following options:</p> <ul style="list-style-type: none"> • Latest: Indicates to use the latest agent software build available in your local inventory, either long-term support (LTS) or feature release (FR). The logic to determine the latest agent is based on the agent version number: the highest version is used. For example, a Deep Security 12 update agent with version 12.0.0.460 is higher than the Deep Security 12 General Availability (GA) agent. However, the Deep Security 12 feature release agents with version 12.5.0.350 is considered later than an LTS agent with version 12.0.0.460. In summary, choose Latest if you want the latest LTS or FR agent for the platform. For details on LTS and FR releases, see "Deep Security 20 release strategy and life cycle policy" on page 104. • Latest LTS: (default) Indicates to use the latest long-term support (LTS) software build available in your local inventory. Latest LTS can be the original LTS release, or can be an update to the original LTS release. Any FRs in your inventory are ignored. LTS build versions always have '0' as the minor version number. For details on LTS and FR releases, see "Deep Security 20 release strategy and life cycle policy" on page 104. • <agent_version> for example, 11.0.0.760: Indicates to use a specific agent version available in your local inventory. Other agents in your inventory are ignored. If no agent version appears in the list, it's because there is

Column	Description
	<p>no agent in your local inventory that matches the OS. To fix this issue, import an agent to your inventory.</p> <p>Note: The latest version of the agent is sometimes a few releases behind your manager version. For example, the latest LTS for Windows Server 2003 is 10.0.0.3377 as of this writing. Although a release may be behind your manager's, it is still supported if you can see it on the Agent Version Control page. For details, see "Agent platform support policy" on page 108.</p>
RESULTING AGENT	<p>This column shows the agent that will be deployed based on your selection under VERSION CONTROL.</p> <p>If the column shows an N/A (No agent in inventory) message, it's because there is no agent in your local inventory that matches the selection in VERSION CONTROL. To fix this issue, import an agent to your inventory or change the VERSION CONTROL selection.</p> <p>If the column shows an N/A (Removed from inventory) message, it's because the primary tenant (T0) deemed the agent unsuitable for deployment and removed it.</p>

Use agent version control with URL requests

Agent version control provides the ability to control what agents are returned when any URL request is made to Deep Security Manager to download the agent. For details, see "[Using agent version control to define which agent version is returned](#)" on page 1801.

Agent version control FAQs

How does version control interact with agent import?

Prior to the introduction of agent version control, the primary way to control the agent

version was to selectively [import](#) only those agents that you were confident you wanted to deploy. Once the agents were imported, the latest one for each platform was distributed to relays. The latest agents were then picked up from the relays by features like [upgrade on activation](#) and [deployment scripts](#).

If you want to continue on this functionality (pre-12 functionality):

1. As before, import the agents you want to deploy to your inventory, and remove the old ones. See ["Get Deep Security Agent software" on page 497](#) for details.
2. Go to the **Agent Version Control** page and make sure all platforms are set to the default, **Latest**. For instructions, see ["Set up agent version control" on page 1442](#).

The **Latest** setting instructs the manager to continue using the latest agents in its local inventory, and you can continue to use your existing processes without any changes.

Is version control supported in multi-tenant deployments?

Yes.

You, as the primary tenant (t0), must import newer agent versions into your local inventory, and then allow each of your tenants to make decisions about what agents they want to deploy using the **Agent Version Control** page. If a tenant only wants to use LTS agents, or lock in to a specific agent version, they can do so independent of other tenants.

Do I need to update my deployment scripts to use this feature?

Yes.

To update your deployment scripts:

1. In Deep Security Manager 12 or later, go to **Support > Deployment Scripts** and generate new deployment scripts. For instructions, see ["Use deployment scripts to add and protect computers" on page 1790](#).
 2. Re-distribute and re-run the new scripts as necessary.
-

The latest deployment scripts pass additional information to Deep Security Manager (for example, tenant information and platform information) that is required for the version control feature to work properly.

What happens if I don't update existing deployment scripts?

If you have existing deployment scripts that you generated prior to the availability of the agent version control feature, and you do not take any action to update them, they will default to **Latest**. This default will be used for any older deployment scripts regardless of how you have set your agent version control settings. Replace the older deployment scripts with new deployment scripts to leverage the settings you define in the agent version control settings.

Deployment scripts that are generated after the availability of the agent version control feature will use your agent version control settings.

What features are out of scope (exceptions)?

By design, the features listed below are out of scope for the agent version control feature. These features are typically accessed by the Deep Security Manager administrator directly, in many cases to test a specific agent version in a development or staging environment prior to deploying the agent version into production.

We have left full access to all agent versions accessible in these specific scenarios:

- the **Computer** details page > **Upgrade Agent** button
- the **Computers > Actions > Upgrade Agent Software** page

Selecting either of the above options launches a wizard with a drop-down list that always defaults to 'Use latest version for platform' regardless of your version control settings. For details, see "[Upgrade the agent from the Computers page](#)" on [page 1628](#).

- agent upgrades that are not initiated directly from Deep Security Manager. For example, if you export an agent package, transfer it to the server, and initiate the upgrade from the command line, the agent version control settings will not be involved in this upgrade.
-

Configure teamed NICs

"Teamed NICs" or "link aggregation" describes forming a network link on a computer by using multiple network interface cards (NICs) together. This is useful to increase the total network bandwidth, or to provide link redundancy.

You can configure teamed NICs on Windows or Solaris so that they are compatible with Deep Security Agent.

Windows

On Windows, when you team NICs, it creates a new virtual interface. This virtual interface adopts the MAC address of its first teamed physical interface.

By default, during installation or upgrade, the Windows Agent will bind to *all* virtual and physical interfaces. This includes the virtual interface created by NIC teaming. However, Deep Security Agent doesn't function properly if multiple interfaces have the same MAC address, which happens with NIC teaming on Windows

To avoid that, bind the agent *only* to the teamed virtual interface - *not* the physical interfaces.

Note: NIC teaming with Deep Security Agent requires Windows 2003 requires SP 2 or later.

Warning: Don't add or remove network interfaces from a teamed NIC *except* immediately before running the installer. Otherwise network connectivity may fail or the computer may not be correctly detected with Deep Security Manager. The agent's network driver is bound to network interfaces when you install or upgrade; the agent does not continuously monitor for changes after.

Solaris

IPMP failover (active-standby) mode in Solaris allows two NICs to have the same hardware (MAC) address. Since the Deep Security Agent identifies network adapters by their MAC address, such duplication prevents the agent from functioning properly.

To avoid that, manually assign a unique MAC address to each network adapter.

For example, you could use `ifconfig` to view the current MAC addresses:

```
# ifconfig -a  
hme0: flags=1000843<BROADCAST,RUNNING,MULTICAST,IPv4> mtu 1500 index 2
```

```
inet 10.20.30.40 netmask 0  
ether 8:0:20:f7:c3:f
```

```
hme1: flags=1000842<BROADCAST,RUNNING,MULTICAST,IPv4> mtu 1500 index 8  
inet 0.0.0.0 netmask 0  
ether 8:0:20:f7:c3:f
```

The "ether" line displays the adapter's MAC address. If any interfaces have the same MAC addresses, and are connected to the same subnet, you must manually set new unique MAC addresses:

```
# ifconfig <interface> ether <new MAC address>
```

Although the chance of a MAC address conflict is extremely small, you should verify that there isn't one by using the snoop command to search for the MAC address, then use the ping command to test connectivity to the subnet's broadcast address.

Note: On Solaris, if multiple interfaces are on the same subnet, the operating system may route packets through any of the interfaces. Because of this, Deep Security's firewall stateful configuration options and IPS rules should be applied to all interfaces equally.

Agent-manager communication

Deep Security Manager and the agent or appliance communicate using the latest mutually-supported version of TLS.

Topics in this article:

- ["Configure the heartbeat" below](#)
- ["Configure communication directionality" on page 1450](#)
- ["Supported cipher suites for agent-manager communication" on page 1452](#)

Configure the heartbeat

A 'heartbeat' is a periodic communication between the Deep Security Manager and agent(or appliance). During a heartbeat, the manager collects this information:

- the status of the drivers (on- or off-line)
- the status of the agent or appliance (including clock time)
- agent or appliance logs since the last heartbeat

- data to update counters
- a fingerprint of the agent or appliance security configuration (used to determine if it is up to date)

The heartbeat can be configured on a base or parent policy, on a sub-policy, or on an individual computer.

You can configure the following properties of the heartbeat:

- **Heartbeat Interval:** How much time passes between heartbeats.
- **Number of Heartbeats that can be missed before an alert is raised:** The number of consecutively missed heartbeats that triggers an alert. For example, a value of three causes the manager to trigger an alert on the fourth missed heartbeat.)

Note: If the computer is a server, too many missed heartbeats in a row may indicate a problem with the agent/appliance or the computer itself. However if the computer is a laptop or any other system that is likely to experience a sustained loss of connectivity, this setting should be set to "unlimited".

- **Maximum change (in minutes) of the local system time on the computer between heartbeats before an alert is raised:** For agents that are capable of detecting changes to the system clock (Windows agents only) these events are reported to the manager as agent event 5004. If the change exceeds the clock change listed here then an alert is triggered. For agents that do not support this capability, the manager monitors the system time reported by the agent at each heartbeat operation and triggers an alert if it detects a change greater than the permissible change specified in this setting.

Note: Once a **Computer-Clock-Changed** alert is triggered, it must be dismissed manually.

- **Raise Offline Errors For Inactive Virtual Machines:** Sets whether an offline error is raised if the virtual machine is stopped.

1. Open the **Policy editor**¹ or the **Computer editor**² for the policy or computer to configure.
2. Go to **Settings > General > Heartbeat**.

¹To open the Policy editor, go to the Policies page and double-click the policy that you want to edit (or select the policy and click Details).

²To open the Computer editor, go to the Computers page and double-click the computer that you want to edit (or select the computer and click Details).

3. Change the properties as required.
4. Click **Save** .

Configure communication directionality

Note: Bidirectional communication is enabled by default.

Configure whether the agent or appliance or the manager initiates communication. 'Communication' includes the heartbeat and all other communications. The following options are available:

Bidirectional: The agent or appliance normally initiates the heartbeat and also listens on the agent's listening port number for connections from the Deep Security Manager. (See ["Deep Security port numbers" on page 411](#).) The manager can contact the agent or appliance to perform required operations. The manager can apply changes to the security configuration of the agent or appliance.

Note: The Deep Security Virtual Appliance can only operate in bidirectional mode. Changing this setting to any other mode for a virtual appliance will disrupt functionality.

- **Manager Initiated:** The manager initiates all communication with the agent or appliance. These communications include security configuration updates, heartbeat operations, and requests for event logs. If you choose this option, we strongly recommend that you ["Protect Deep Security Agent" on page 1567](#) so that it only accepts connections from known Deep Security Managers.
- **Agent/Appliance Initiated:** The agent or appliance does not listen for connections from the manager. Instead they contact the manager on the port number where the Manager listens for agent heartbeats. (See ["Deep Security port numbers" on page 411](#).) Once the agent or appliance has established a TCP connection with the manager, all normal communication takes place: the manager first asks the agent or appliance for its status and for any events. (This is the heartbeat operation.) If there are outstanding operations that need to be performed on the computer (for example, the policy needs to be updated), these operations are performed before the connection is closed. Communications between the manager and the agent or appliance only occur on every heartbeat. If an agent or appliance's security configuration has changed, it is not updated until the next heartbeat.

Note: For instructions on how to configure agent-initiated activation and use deployments scripts to activate agents, see "[Activate and protect agents using agent-initiated activation and communication](#)" on page 1460.

Note: To enable communications between the Manager and the agents and appliances, the manager automatically implements a (hidden) firewall rule (priority four, Bypass) that opens the listening port number for heartbeats on the agents and appliances to incoming TCP/IP traffic. By default, it will accept connection attempts from any IP address and any MAC address. You can restrict incoming traffic on this port by creating a new priority 4, Force Allow or Bypass firewall rule that only allows incoming TCP/IP traffic from specific IP or MAC addresses, or both. This new firewall rule would replace the hidden firewall rule if the settings match these settings:

action: force allow or bypass

priority: 4 - highest

packet's direction: incoming

frame type: IP

protocol: TCP

packet's destination port: agent's listening port number for heartbeat connections from the manager, or a list that includes the port number. (See [agent listening port number](#).)

While these settings are in effect, the new rule will replace the hidden rule. You can then type packet source information for IP or MAC addresses, or both, to restrict traffic to the computer.

1. Open the **Policy editor**¹ or the **Computer editor**² for the policy or computer to configure.
2. Go to **Settings > General > Communication Direction**.
3. In the **Direction of Deep Security Manager to Agent/Appliance communication** menu, select one of the three options ("Manager Initiated", "agent/appliance Initiated", or "Bidirectional"), or choose "Inherited". If you select "Inherited", the policy or computer inherits the setting from its parent policy. Selecting one of the other options overrides the

¹To open the Policy editor, go to the Policies page and double-click the policy that you want to edit (or select the policy and click Details).

²To open the Computer editor, go to the Computers page and double-click the computer that you want to edit (or select the computer and click Details).

inherited setting.

4. Click **Save** to apply the changes.

Note: Agents and appliances look for the Deep Security Manager on the network by the Manager's hostname. Therefore the Manager's hostname **must** be in your local DNS for agent- or appliance-initiated or bidirectional communication to work.

Supported cipher suites for agent-manager communication

Deep Security Manager and the agent or appliance communicate using the latest mutually-supported version of TLS.

The Deep Security Agent supports the following cipher suites for communication with the manager. If you need to know the cipher suites supported by the Deep Security Manager, contact Trend Micro. If you need to know the cipher suites supported by the Deep Security Virtual Appliance, determine the version of the agent that's embedded on the appliance, and then look up that agent in the list below.

The cipher suites consist of a key exchange asymmetric algorithm, a symmetric data encryption algorithm and a hash function.

- ["Deep Security Agent 9.6 cipher suites" below](#)
- ["Deep Security Agent 10.0 cipher suites" below](#)
- ["Deep Security Agent 11.0, 12.0, and 20 cipher suites" on the next page](#)

Deep Security Agent 9.6 cipher suites

Deep Security Agent 9.6 supports these TLS 1.0 cipher suites:

- TLS_RSA_WITH_AES_256_CBC_SHA
- TLS_RSA_WITH_AES_128_CBC_SHA

Deep Security Agent 10.0 cipher suites

Deep Security Agent 10.0 supports these TLS 1.2 cipher suites, out-of-box:

- TLS_RSA_WITH_AES_256_CBC_SHA256
- TLS_RSA_WITH_AES_128_CBC_SHA256

Deep Security Agent 10.0 Update 16 and later supports these TLS 1.2 cipher suites, and only these suites, if [strong cipher suites are enabled](#):

- TLS_ECDHE_RSA_WITH_AES_256_GCM_SHA384
- TLS_ECDHE_RSA_WITH_AES_128_GCM_SHA256
- TLS_ECDHE_RSA_WITH_AES_256_CBC_SHA384
- TLS_ECDHE_RSA_WITH_AES_128_CBC_SHA256

Deep Security Agent 11.0, 12.0, and 20 cipher suites

Deep Security Agent 11.0 and later supports these TLS 1.2 cipher suites:

- TLS_ECDHE_RSA_WITH_AES_256_GCM_SHA384
- TLS_ECDHE_RSA_WITH_AES_128_GCM_SHA256
- TLS_ECDHE_RSA_WITH_AES_256_CBC_SHA384
- TLS_ECDHE_RSA_WITH_AES_128_CBC_SHA256

[In FIPS mode](#), these TLS 1.2 suites are supported:

- TLS_RSA_WITH_AES_256_CBC_SHA256
- TLS_RSA_WITH_AES_128_CBC_SHA256

Configure agents that have no internet access

If your agents or relays don't have access to the internet (also called "air-gapped agents"), then they won't be able to access several of the security services provided by the Trend Micro Smart Protection Network. These security services are necessary for the full and successful operation of the Deep Security Anti-Malware and Web Reputation features.

The Trend Micro Smart Protection Network security services are:

Service name	Required for these features
Smart Scan Service	Smart Scan
Web Reputation Service	Web Reputation
Global Census Service	behavior monitoring , predictive machine learning
Good File Reputation Service	behavior monitoring , predictive machine learning , process

Service name	Required for these features
	memory scans
Predictive Machine Learning Service	predictive machine learning

In addition to the above services, the agent and relay-enabled agent also need access to the Trend Micro Update Server (also called "Active Update"), which is not part of the Smart Protection Network, but is a component that is hosted by Trend Micro and accessed over the internet.

If any of your agents or relay-enabled agents can't reach the services above, you have several solutions, described below.

Solutions

- Solution 1: ["Use a proxy" below](#)
- Solution 2: ["Install a Smart Protection Server locally " below](#)
- Solution 3: ["Get updates in an isolated network" on the next page](#)
- Solution 4: ["Disable the features that use Trend Micro security services" on page 1458](#)

Use a proxy

If your agents or relay-enabled agents can't connect to the internet, you can install a proxy that can. Your Deep Security Agents and relays connect to the proxy, and the proxy then connects outbound to the Trend Micro security services in the Smart Protection Network.

Note: With a proxy, each Smart Scan or Web Reputation request goes out over the internet to the Smart Protection Network. Consider instead [using a Smart Protection Server inside your LAN](#) to keep these requests within your network and reduce extranet bandwidth usage.

To use a proxy, see ["Configure proxies" on page 1404](#).

Install a Smart Protection Server locally

If your agents and relay-enabled agents can't connect to the internet, you can install a Smart Protection Server in your local area network (LAN) to which they *can* connect. The local Smart

Protection Server periodically connects outbound over the internet to the Smart Protection Network to retrieve the latest Smart Scan Anti-Malware patterns and Web Reputation information. This information is cached on the Smart Protection Server and queried by your agents and relay-enabled agents. The Smart Protection Server does not push updates to the agents or relay-enabled agents.

If you decide to use this solution, remember that:

- Functionality is limited. Only the [Smart Scan](#) and [Web Reputation](#) features are supported with a local Smart Protection Server.
- Use the proxy solution if you need the [behavior monitoring](#), [predictive machine learning](#), and [process memory scanning](#) features. See "Use a proxy" on the previous page above for details. If you decide not to use these features, you must disable them to prevent a query failure and to improve performance. For instructions on disabling these features, see ["Disable the features that use Trend Micro security services" on page 1458](#)

To deploy a Smart Protection Server:

- install it manually. See the [Smart Protection Server documentation](#) for details.
OR
- if your agents or relay-enabled agents are inside AWS, install it using an AWS CloudFormation template created by Trend Micro. See ["Integrate with Smart Protection Server" on page 1894](#) for details.

The scenario described above applies when only the Deep Security Agent and relay-enabled agent are air-gapped, but Deep Security Manager has internet access or proxy access as described in ["Port numbers, URLs, and IP addresses" on page 410](#). If Deep Security Manager is also air-gapped, you will need to use a proxy to receive security updates from the Trend Micro Active Update Server. Alternatively, use Solution 3: ["Get updates in an isolated network" below](#).

Get updates in an isolated network

If your Deep Security Manager is in an isolated network without connection to the internet and your agents or relay-enabled agents also can't connect to the internet, you can install an additional stand-alone Deep Security Manager with database and a relay-enabled agent in your [demilitarized zone \(DMZ\)](#) or another area where internet access is available.

Once all the components are installed, you can configure the relay-enabled agent in the DMZ to automatically obtain the latest malware scan updates from the Update Server on the internet.

These updates must be extracted to a .zip file, and then manually copied to your air-gapped relay. (Detailed instructions follow.)

If you decide to use this solution, remember that:

- The .zip file contains traditional (large) malware patterns, which give you basic Anti-Malware capabilities.
- The .zip file also contains Deep Security Rule Updates, which are used for [Intrusion Prevention](#), [Integrity Monitoring](#), and [Log Inspection](#). You can also choose to obtain those updates separately (See "[Get rules updates in an isolated network](#)" on page 1458).
- The following advanced Anti-Malware features are *not* available: [Smart Scan](#), [behavior monitoring](#), [predictive machine learning](#), [process memory scans](#), and [Web Reputation](#). These features all require access to Trend Micro security services.
- You should [disable the advanced Anti-Malware features](#) (Solution 4) since they cannot be used.
- You should have a plan in place to periodically update the .zip file on your air-gapped relay to ensure you always have the latest malware patterns.

To deploy this solution, follow these steps (for upgrade steps, see below):

1. Install a Deep Security Manager and its associated database in your DMZ. We'll call these internet-facing components the 'DMZ manager' and 'DMZ database'.
2. Install a Deep Security Agent in your DMZ and configure it as a relay. We'll call this agent the 'DMZ relay'. For information on setting up relays, see "[Deploy additional relays](#)" on [page 1415](#).

The following items are now installed:

- a DMZ manager
 - a DMZ database
 - a DMZ relay
 - an air-gapped manager
 - an air-gapped database
 - an air-gapped relay
 - multiple air-gapped agents
3. On the DMZ relay, create a .zip file containing the latest malware patterns by running this command:

```
dsa_control -b
```

The command line output shows the name and location of the .zip file that was generated.

4. Copy the .zip file to the air-gapped relay. Place the file in the relay's installation directory.
 - On Windows the default directory is `C:\Program Files\Trend Micro\Deep Security Agent`.
 - On Linux the default directory is `/opt/ds_agent`.

Note: Do not rename the .zip file.

5. On the air-gapped manager, initiate a security update download:
 - a. Click **Computers** at the top.
 - b. In the list of computers, find your air-gapped relay where you copied the .zip file, right-click it and select **Download Security Update**.

The air-gapped relay checks its configured update source (typically the Update Server on the internet). Since it can't connect to this server, it checks the .zip file in its installation directory. When it finds the .zip file, it extracts it and imports the updates. The updates are then disseminated to the air-gapped agents that are configured to connect to the relay.
 - c. Delete the .zip file after the updates are imported to the air-gapped relay.
6. Configure the air-gapped relay to connect to itself instead of the Update Server (to prevent connection error alerts):
 - a. Log in to the air-gapped manager.
 - b. Click **Administration** on the top.
 - c. On the left, click **System Settings**.
 - d. In the main pane, click the **Updates** tab.
 - e. Under **Primary Security Update Source**, select **Other update source** and enter `https://localhost:[port]` where `[port]` is the [configured port number for security updates](#), by default 4122.
 - f. Click **OK**.

The air-gapped relay no longer tries to connect to the Update Server on the internet.
7. (Optional but recommended.) To improve performance, "[Disable the features that use Trend Micro security services](#)" on the next page.
8. On a periodic basis, download the latest updates to your DMZ relay, zip them up, copy them to your air-gapped relay, and initiate a security update download on the relay.

You have now deployed a Deep Security Manager, associated database, and relay in your DMZ from which to obtain malware scan updates.

To upgrade this solution, upgrade in this order:

1. DMZ manager (and its database, if the database software also needs to be upgraded)
2. DMZ relay

3. air-gapped manager (and its database, if the database software also needs to be upgraded)
4. air-gapped relay
5. air-gapped agents

Warning: If you do not upgrade relays first, security component upgrades and software upgrades may fail.

For details on upgrading, see ["Install Deep Security Manager" on page 442](#) (for manager upgrade steps), ["Upgrade Deep Security Relay" on page 1624](#), and ["Upgrade Deep Security Agent" on page 1625](#).

Get rules updates in an isolated network

The .zip file that you created in the previous section contains the Deep Security Rule Updates that are used for Intrusion Prevention, Integrity Monitoring, and Log Inspection. However, if you would like to get those updates separately:

1. On the DMZ manager, go to **Administration > Updates > Security > Rules**.
2. Click a rule update (.dsru file) and click **Export**. The file is downloaded locally.
3. Repeat the export for each .dsru file that you want to apply to the air-gapped manager.
4. Copy the .dsru files to the air-gapped manager.
5. On the air-gapped manager, go to **Administration > Updates > Security > Rules**.
6. Click **Import**, select the .dsru file, and click **Next**.
7. The manager validates the file and displays a summary of the rules it contains. Click **Next**.
8. A message displays, saying that the rule update was imported successfully. Click **Close**.
9. Repeat the import for each .dsru file that you want to apply to the air-gapped manager.

Disable the features that use Trend Micro security services

You can disable the features that use Trend Micro security services. Doing so improves performance because the air-gapped agent no longer tries (and fails) to query the services.

Note: Without Trend Micro security services, your malware detection is downgraded significantly, ransomware is not detected at all, and process memory scans are also affected. It is therefore strongly recommended that you use one of the other solutions to allow access to Trend Micro security services. If this is impossible, only then should you disable features to realize performance gains.

- To disable Smart Scans:
 - a. Open the **Computer or Policy editor**¹.
 - b. On the left, click **Anti-Malware**.
 - c. In the main pane, click **Smart Protection**.
 - d. Under **Smart Scan**, deselect **Inherited** (if it is selected) and then select **Off**.
 - e. Click **Save**.
- To disable web reputation:
 - a. Open the **Computer or Policy editor**².
 - b. On the left, click **Web Reputation**.
 - c. In the main pane, make sure the **General** tab is selected.
 - d. From the **Configuration** drop-down list, select **Off**.
 - e. Click **Save**.
- To disable Smart Feedback:
 - a. In Deep Security Manager, click **Administration** at the top.
 - b. Click **System Settings** on the left.
 - c. In the main pane, click the **Smart Feedback** tab.
 - d. Deselect **Enable Trend Micro Smart Feedback (recommended)**.
 - e. Click **Save**.
- To disable process memory scans:
 - a. In Deep Security Manager, click **Policies** at the top.
 - b. On the left, expand **Common Objects > Other** and then click **Malware Scan Configurations**.
 - c. Double-click a malware scan configuration with a **SCAN TYPE** of **Real-Time**.
 - d. On the **General** tab, under **Process Memory Scan**, deselect **Scan process memory**

¹You can change these settings for a policy or for a specific computer. To change the settings for a policy, go to the Policies page and double-click the policy that you want to edit (or select the policy and click Details). To change the settings for a computer, go to the Computers page and double-click the computer that you want to edit (or select the computer and click Details).

²You can change these settings for a policy or for a specific computer. To change the settings for a policy, go to the Policies page and double-click the policy that you want to edit (or select the policy and click Details). To change the settings for a computer, go to the Computers page and double-click the computer that you want to edit (or select the computer and click Details).

for malware.

- e. Click **OK**.
- To disable predictive machine learning:
 - a. Make sure you still have a real-time malware scan configuration open.
 - b. On the **General** tab, under **Predictive Machine Learning**, deselect **Enable Predictive Machine Learning**.
 - c. Click **OK**.
- To disable behavior monitoring:
 - a. Make sure you still have a real-time malware scan configuration open.
 - b. On the **General** tab, under **Behavior Monitoring**, deselect **Enable Behavior Monitoring**.
 - c. Click **OK**.

Also disable the census and grid queries on the Deep Security Manager if you want performance gains. If you leave them enabled, a lot of unnecessary background processing takes place. To disable these queries:

1. Disable the census query:

```
dsm_c -action changesetting -name settings.configuration.enableCensusQuery -value false
```

2. Disable the grid query:

```
dsm_c -action changesetting -name settings.configuration.enableGridQuery -value false
```

Activate and protect agents using agent-initiated activation and communication

When you enable agent-initiated activation (AIA), instead of the Deep Security Manager contacting the agents directly, the agents initiate communication with the manager and establish an encrypted TCP connection over the manager heartbeat [port](#) (4120 by default).

Enabling AIA can prevent communication issues between the manager and agents, and simplify agent deployment when used with deployment scripts. Trend Micro recommends that you use AIA if:

- Your network environment prevents the manager from initiating connections to agents.
- You need to deploy many agents at once.
- You are protecting computers in cloud accounts.

Note: Before enabling AIA, ensure that agents can reach the manager URL and heartbeat port. You can find the manager URL(s) and heartbeat port under **Administration > System Information > System Details > Manager Node**.

Enable agent-initiated activation and communication

Proceed with the following steps:

1. "Create or modify policies with agent-initiated communication enabled" below.
2. "Enable agent-initiated activation" below.
3. "Assign the policy to agents" on the next page.
4. "Use a deployment script to activate the agents" on the next page.

Create or modify policies with agent-initiated communication enabled

For your agents to continue initiating communication with the manager after activation, you'll need to enable agent-initiated communication on any policies the agents will use. You can do this by either modifying an existing policy or by creating a new one, which you'll assign to the agents.

Tip: You can quickly create a new policy from an existing policy by right-clicking it and selecting **Duplicate**.

1. On the **Policies** page, double-click the policy.
2. Go to **Settings > General**.
3. Under Communication Direction, select **Agent/Appliance Initiated**.
4. Click **Save**.

Enable agent-initiated activation

1. Go to **Administration > System Settings > Agents**.
2. Select **Allow Agent-Initiated Activation**.
3. Select **Allow Agent to specify hostname**.
4. From the **If a computer with the same name exists** list, select **Re-activate the existing**

computer.

5. Click **Save**.

Note: For a full description of each AIA setting, see the [Agent-Initiated Activation](#) section of "Agent settings" on page 1474.

Assign the policy to agents

You can either assign the policy to the agents during the deployment script configuration, or by using an event-based task after the deployment script has been run.

If all the agents will use the same policy, you can assign the policy in the deployment script as part of the next step. If groups of agents need to use different policies, [create an event-based task to assign the policies](#) before proceeding with the next step.

Use a deployment script to activate the agents

See the [Generate a deployment](#) section of "Generate a deployment script" on page 1790 to learn how to use a deployment script to activate the agents. If you are assigning a policy during deployment script configuration, you'll select it from the **Security Policy** list.

Automatically upgrade agents on activation

'Upgrade on activation' is a feature that can be used to automatically upgrade Deep Security Agents to a newer version of software based on a check of the agent version during the activation process. This feature is especially useful if you want to distribute the agent using the baking process (see ["Install the agent on an AML or WorkSpace bundle" on page 528](#)). When agents are baked it can be difficult for you to update your 'golden' images each time a new version of the Deep Security Agent is released. In this case, 'upgrade on activation' can be used so that each time the older agent from the baked image activates, Deep Security Manager instructs the agent to upgrade to the version you specify as part of the activation process keeping the running agents used in your environment up-to-date.

Note: This feature complies with your [agent version control](#) settings.

Note: This feature is currently available only on Linux and Windows computers. Support for Unix is planned for a future release.

This feature works with these operating systems:

- Red Hat Enterprise Linux
- Ubuntu
- CentOS
- Debian
- Amazon Linux
- Oracle Linux
- SUSE Linux Enterprise Server
- Cloud Linux
- Windows

Enable automatic agent upgrade

1. Make sure the latest agent software and kernel support packages are available in Deep Security Manager. You can configure Deep Security Manager to automatically download software updates, or import them manually. For details, see ["Get Deep Security Agent software" on page 497](#).
2. Go to **Administration > System Settings > Agents**.
3. Under **Agent Upgrade**, select any of the following: **Automatically upgrade Linux agents on activation**, **Automatically upgrade Windows agents on activation**, **Automatically upgrade Unix agents on activation**.
4. Click **Save**.

Check that agents were upgraded successfully

The **Version** column on the **Computers** page displays the installed Deep Security Agent version for each computer.

In addition, when an automatic agent upgrade is triggered, [" System events" on page 1298](#) are generated that you can use to track the status of the upgrade. You can check for these system events:

ID	Event	Description
264	Agent Software Upgrade Requested	An agent software upgrade has been triggered, either manually or by an automatic agent upgrade.

ID	Event	Description
277	Upgrade on Activation Skipped	<p>The agent was eligible for an automatic upgrade, but the upgrade did not occur.</p> <p>The event details list the existing agent version and the attempted upgrade version, along with the reason the upgrade failed. The reasons can be:</p> <ul style="list-style-type: none"> • Upgrade on activation was skipped for this computer because there is a pending reboot request. Please restart the computer to resolve this issue. The upgrade request will be serviced during the next activation after the reboot. • Upgrade on activation is not currently supported for use on Windows servers when the target version to upgrade to is earlier than Deep Security Agent 12. There are improvements in the 12 agent that are required for this feature. Please update the agent version control configuration to use a 12 or later agent for this platform to allow the upgrade to succeed. • The agent was not upgraded automatically because a required Linux kernel support file was not found. Deep Security Manager usually downloads required Linux kernel support packages automatically, but you can also download and import packages to Deep Security Manager manually and then upgrade the agent. See "Get Deep Security Agent software" on page 497. • The agent was not upgraded automatically because the upgrade on activation feature does not support the currently installed OS. You may be able to upgrade the agent manually. See "Install the agent" on page 515.
706	Software Update: Agent Software Upgraded	The upgrade was successful.
707	Software Update: Agent Software Upgrade	The upgrade was not successful. Refer to the event details for more information about why it was not successful.

ID	Event	Description
	Failed	

Using Deep Security with iptables

When Deep Security Agent 10.1 or earlier was installed on Linux, it disabled the iptables service to avoid firewall conflicts unless you added a configuration file that prevented that change. However, the iptables service is used for more than just firewall (for example, Docker manages iptables rules as part of its normal operation), so disabling it sometimes had negative consequences.

With Deep Security 10.2 and higher (including Deep Security 11), the functionality around iptables has changed. Deep Security Agent no longer disables iptables. (If iptables is enabled, it stays enabled after the agent installation. If iptables is disabled, it stays disabled.) However, if the iptables service is running, Deep Security Agent and Deep Security Manager require certain iptables rules, as described below.

Rules required by Deep Security Manager

If iptables is enabled on the computer where Deep Security Manager is being installed, there are two required iptables rules. By default, these rules are added when Deep Security Manager starts up and removed when the manager is stopped or uninstalled. Alternatively, you can ["Prevent Deep Security from automatically adding iptables rules" on the next page](#) and add them manually instead:

- Allow incoming traffic on port 4119. This is required for access to the Deep Security Manager web UI and API.
- Allow incoming traffic on port 4120. This is required to listen for agent heartbeats. (For more information, see ["Agent-manager communication" on page 1448.](#))

Note: These are the default port numbers - yours may be different. For a complete list of ports used in Deep Security, see ["Port numbers, URLs, and IP addresses" on page 410.](#)

Rules required by Deep Security Agent

If iptables is enabled on the computer where Deep Security Agent is being installed, iptables may require additional rules. By default, these rules are added when Deep Security Agent starts

up and removed when the agent is stopped or uninstalled. Alternatively, you can ["Prevent Deep Security from automatically adding iptables rules" below](#) and add them manually instead:

- Allow incoming traffic on port 4118. This is required when the agent uses manager-initiated or bidirectional communication. (For more information, see ["Agent-manager communication" on page 1448.](#))
- Allow incoming traffic on port 4122. This is required when the agent is acting as a relay, so that the relay can distribute software updates. (For more information, see ["Deploy additional relays" on page 1415.](#))

Note: These are the default port numbers - yours may be different. For a complete list of ports used in Deep Security, see ["Port numbers, URLs, and IP addresses" on page 410.](#)

Prevent Deep Security from automatically adding iptables rules

You can prevent Deep Security Manager and Deep Security Agent from modifying iptables if you would rather add the required rules manually. To prevent the automatic modification of iptables, create the following file on the computers where you plan to install Deep Security Manager and Deep Security Agent:

```
/etc/do_not_open_ports_on_iptables
```

Enable or disable agent self-protection on Windows

Agent self-protection prevents local users from tampering with the agent. When enabled, if a user tries to tamper with the agent, a message such as "Removal or modification of this application is prohibited by its security settings" is displayed.

To update or uninstall Deep Security Agent or relay, or if you are a local user trying to create a diagnostic package for support from the command line, as described in [Create a diagnostic package and logs](#), you must temporarily disable agent self-protection.

Anti-Malware protection must be enabled to prevent users from stopping the agent, as well as from modifying agent-related files and Windows registry entries. However, it is not required to prevent uninstalling the agent.

You can configure agent self-protection using either Deep Security Manager or the command line on the agent's computer.

Note: The agent self-protection feature is also available for agents on Linux. For more information, see [Enable or disable agent self-protection on Linux](#).

Configure self-protection through Deep Security Manager

1. Open the **Computer or Policy editor**¹ where you want to enable agent self-protection.
2. Select **Settings > General**.
3. In the **Agent Self-Protection** section, select **Yes** to prevent local end-users from uninstalling, stopping, or otherwise modifying the agent.
4. For **Local override requires password**, select **Yes** and type an authentication password. The authentication password is highly recommended because it prevents an unauthorized use of the [dsa_control command](#). After specifying the password, it must be entered with the `dsa_control` command using the `-p` or `--passwd=` option whenever a command is run on the agent.
5. Click **Save**.
6. To disable the setting, select **No**.
7. Click **Save**.

Configure agent self-protection using the command line

You can enable and disable self-protection using the command line, with one limitation: you cannot specify an [authentication password](#). You need to use Deep Security Manager for that. See "[Configure self-protection through Deep Security Manager](#)" above for details.

1. Log in to the Windows agent locally.
2. Open the command prompt (`cmd.exe`) as an Administrator.
3. Change the current directory to the Deep Security Agent installation folder. The following shows the default installation folder:

```
cd C:\Program Files\Trend Micro\Deep Security Agent
```

4. Enter one of the following commands:

To enable agent self-protection, enter:

¹You can change these settings for a policy or for a specific computer. To change the settings for a policy, go to the Policies page and double-click the policy that you want to edit (or select the policy and click Details). To change the settings for a computer, go to the Computers page and double-click the computer that you want to edit (or select the computer and click Details).

```
dsa_control --selfprotect=1
```

To disable agent self-protection, enter:

```
dsa_control --selfprotect=0 -p <password>
```

where `-p <password>` is the authentication password, if one was previously specified in Deep Security Manager. For details, see "[Configure self-protection through Deep Security Manager](#)" on the previous page.

Enable or disable agent self-protection on Linux

Note: The agent self-protection feature is supported by Deep Security Agent version 20.0.0.5953 and later. This feature is available for agents on both Linux and Windows. For more information, see [Enable or disable agent self-protection on Windows](#).

Agent self-protection prevents local users from tampering with the agent. When enabled, if the user is prevented from tampering.

To uninstall Deep Security Agent, user must first disable agent self-protection.

You can configure agent self-protection by using either Deep Security Manager or the command line on the agent's computer. However, you must configure agent self-protection through Deep Security Manager for the first time.

Before using agent self-protection, you must enable at least one of the following:

- Anti-Malware
- Application Control
- Integrity Monitoring with Real Time enabled
- Activity Monitoring

Configure self-protection through Deep Security Manager

1. Click **Settings > General**.
2. In the **Agent Self-Protection** section, for **Prevent local end-users from uninstalling, stopping, or otherwise modifying the Agent**, select **Yes**.
3. For **Local override requires password**, select **Yes** and type an authentication password. An authentication password is highly recommended because it prevents the unauthorized

use of the [dsa_control command](#). When a password is required, it must be entered with the `dsa_control` command using the `-p` or `--passwd=` option whenever a command is run on the agent.

4. Click **Save**.

Configure self-protection using the command line

You can enable and disable self-protection using the command line, with one limitation: you cannot specify an authentication password. You need to use Deep Security Manager for that. See [Configure self-protection through Deep Security Manager](#) for details.

1. Open the command prompt as an Administrator.
2. Change the current directory to the Deep Security Agent installation folder. The following shows the default install folder:

```
cd /opt/ds_agent
```

3. Enter one of the following commands:

To enable agent self-protection, enter:

```
dsa_control --selfprotect=1
```

To disable agent self-protection, enter:

```
dsa_control --selfprotect=0 -p <password>
```

where `-p <password>` is the authentication password, if one was specified previously in Deep Security Manager. For details on this password, see ["Configure self-protection through Deep Security Manager" on the previous page](#).

Limitations

- The agent service cannot be stopped when the system is shutting down or rebooting. Stopping the service may prevent it from working properly after the reboot.
- The status of the agent service may be inconsistent. If you try to stop the agent service running the command `stop`, the result returned as successful, however the agent service still runs as normal.
- If there is a running process that has the same name as an agent process in the system, it

is added to the self-protection list. The protected process is protected from tampering.

- The agent service cannot be killed when Out-Of-Memory (OOM) happens.
- Oracle 6 (32-bit) platform does not support self protection.
- If you have enabled secure boot and self-protection is not working, check your machine's kernel version. If the kernel version is 5.4 or earlier, upgrade to a kernel version that is later than 5.4.

Troubleshooting

To recover the service status back to normal, follow these steps:

1. Stop agent self-protection.
2. Restart the agent service.

Agent self-protection resumes after the agent service restarts.

Are "Offline" agents still protected by Deep Security?

Agents showing as "Offline" in the Deep Security Manager are still being protected according to their last known configuration. However, they will not receive any software, security or policy updates until communication with the Deep Security Manager is restored.

For more information on how to bring an agent out of "Offline" status, see ["Offline" agent](#) on page 1918.

Automate offline computer removal with inactive agent cleanup

If your Deep Security deployment has a large number of offline computers not communicating with the Deep Security Manager, first try using a connector (see ["About adding AWS accounts" on page 640](#), ["Add a Microsoft Azure account to Deep Security" on page 665](#), or ["Add a Google Cloud Platform account" on page 677](#)). When you use a connector, the complete life cycle of your computers is managed automatically, meaning that computers deleted from your cloud accounts are also automatically removed from Deep Security. If you can't use a connector in your environment, you can automate the removal of inactive computers using **inactive agent**

cleanup. Inactive agent cleanup will check hourly for computers that have been offline and inactive for a specified period of time (from 2 days to 12 months) and remove them.

Note: Inactive agent cleanup will remove a maximum of 1000 offline computers at each hourly check. If there are more offline computers than this, 1000 will be removed at each consecutive check until all of the offline computers have been removed.

After enabling inactive agent cleanup, you can also

- ["Ensure computers that are offline for extended periods of time remain protected with Deep Security" below](#) (optional but recommended).
- ["Set an override to prevent specific computers from being removed" on the next page](#) (optional).
- ["Check the audit trail for computers removed by an inactive cleanup job" on the next page.](#)

Note: Inactive agent cleanup does not remove offline computers that have been added by a cloud connector.

Enable inactive agent cleanup

1. Go to the **Administration** page.
2. Under **System Settings > Agents > Inactive Agent Cleanup**, select **Delete Agents that have been inactive for**.
3. From the list, select the period that a computer must be inactive before being removed.
4. ["Ensure computers that are offline for extended periods of time remain protected with Deep Security" below](#) (optional but recommended).
5. Click **Save**.

Ensure computers that are offline for extended periods of time remain protected with Deep Security

If you have offline computers that are active but communicate irregularly with the Deep Security Manager, inactive agent cleanup will remove them if they don't communicate within the period of inactivity you defined. To ensure that these computers reconnect to Deep Security Manager, we recommend enabling both **Agent-Initiated Activation** and **Reactivate unknown Agents**. To do so, under **System Settings > Agents > Agent Initiated Activation**, first select **Allow Agent-Initiated Activation** and then select **Reactivate Unknown Agents**.

Note: When a removed computer reconnects, it will not have a policy, and will be added as a new computer. Any direct links to the computer will be removed from the Deep Security Manager event data.

Tip: You can automatically assign a policy assigned to a computer upon agent-initiated activation with an [event-based task](#).

Set an override to prevent specific computers from being removed

You can set an override at the computer or policy level to explicitly prevent computers from being removed by inactive agent cleanup.

To set an override

1. Open the **Computer or Policy editor**¹ for the computer or policy you want to set an override on.
2. Go to **Settings > General**.
3. Under **Inactive Agent Cleanup Override**, select **Yes**.
4. Click **Save**.

Check the audit trail for computers removed by an inactive cleanup job

When an inactive agent cleanup job runs, system events will be generated that you can use to track removed computers.

You'll need to check the following system events:

- ["2953 - Inactive Agent Cleanup Completed Successfully" on the next page](#)
- ["251 - Computer Deleted" on the next page](#)
- ["716 - Reactivation Attempted by Unknown Agent" on the next page](#) (if 'Reactivate Unknown Agents' is enabled)

Search system events

To view the system events generated by an inactive agent cleanup job, you need to create a search that filters for them:

¹You can change these settings for a policy or for a specific computer. To change the settings for a policy, go to the Policies page and double-click the policy that you want to edit (or select the policy and click Details). To change the settings for a computer, go to the Computers page and double-click the computer that you want to edit (or select the computer and click Details).

1. Go to the **Events and Reports** page.
2. In the top-right corner, click the Search field list and select **Open Advanced Search**.

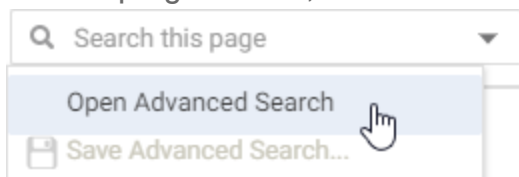

3. For the **Period**, select **Custom Range** from the list.
4. For **From**, enter the date and time just before the inactive agent cleanup job was first run. For **To**, enter the date and time just after the cleanup job finished.
5. For the **Search**, select **Event ID** and **In**, and then enter **2953, 251**. You can optionally enter **716** and any of the event IDs (**130, 790, 350, 250**) associated with computer reactivation.

This will display all the system events generated by an inactive agent cleanup job. You can sort the events by time, event ID or event name by clicking on the corresponding column. You can then double-click an event to get more information about it, as detailed below.

System event details

2953 - Inactive Agent Cleanup Completed Successfully

This event is generated when the inactive agent cleanup job runs and successfully removes computers. The description for this event will tell you how many computers were removed.

Note: If more than one check is needed to remove all computers, a separate system event will be generated for each check.

251 - Computer Deleted

In addition to the 'Inactive Agent Cleanup Completed Successfully' event, a separate 'Computer Deleted' event is generated for each computer that was removed.

716 - Reactivation Attempted by Unknown Agent

If **Reactivate Unknown Agents** is enabled, this event will be generated for an activated computer that was removed when it attempts to reconnect to the Deep Security Manager. Each reactivated computer will also generate the following system events:

- **130** - Credentials Generated
- **790** - Agent-Initiated Activation Requested
- **350** - Policy Created (if you've enabled an event-based task that assigns a policy)

- 250 - Computer Created
or
252 - Computer Updated

Agent settings

Deep Security Agent-related settings are located on **Administration > System Settings > Agents**. They include the following.

Tip: You can automate agent-related system setting changes using the Deep Security API. For examples, see [Configure Policy, Computer, and System Settings](#).

Hostnames

Update the "Hostname" entry if an IP is used as a hostname and a change in IP is detected on the computer after **Agent/Appliance-initiated communication or discovery**: Updates the IP address displayed in the computer's "Hostname" property field if an IP change is detected.

Note: Deep Security Manager identifies protected computers by using a unique fingerprint, not their IP addresses or hostnames.

Agent-initiated activation (AIA)

You can activate new agents in the Deep Security Manager using a cloud connector or by manually adding a new computer on **Computers**. Alternatively, you can allow agents to automatically activate themselves. See also "[Activate and protect agents using agent-initiated activation and communication](#)" on page 1460.

Allow Agent-Initiated Activation: Allow agents to connect to the manager to activate themselves. Then select which computers are allowed to perform agent-initiated activation.

- **For Any Computers:** Any computer, whether it is already listed on **Computers** or not.

Warning: To prevent unauthorized agent activations, don't enable this option if your network allows connections to Deep Security Manager from untrusted networks such as the Internet. To similarly protect Deep Security Agent from unauthorized managers, [only allow agent activation with your authenticated manager](#).

- **For Existing Computers:** Only computers already listed on **Computers**.
- **For Computers on the following IP List:** Only computers whose IP address has a match on the specified IP list.

Also configure initiation behavior:

- **Policy to assign (if Policy not assigned by activation script):** Security policy to assign to the computer during activation. This setting only applies if no policy is specified in the agent's activation script or an AIA event-based task.
- **Allow Agent to specify hostname:** Allow the agent to specify its hostname by providing it to Deep Security Manager during activation.
- **If a computer with the same name already exists:** How to handle the activation attempt if the new computer is trying to use the same agent GUID or certificate as an existing computer:
 - **Do not allow activation:** Don't activate the computer.
 - **Activate a new Computer with the same name:** Using a new name, create a new computer object and activate the computer.
 - **Re-activate the existing Computer:** Keeping the same name, reuse the existing computer object and activate the computer.

This setting only applies to physical computers, Azure virtual machines (VMs), Google Cloud Platform (GCP) VMs, or VMware VMs. (AWS provides a unique instance ID that Deep Security Manager uses to differentiate all AWS instances, so this setting is ignored for those computers.)

- **Reactivate cloned Agents:** Reactivate clones as new computers; assign the the policy selected in [Policy to assign \(if Policy not assigned by activation script\)](#). This can be useful when re-imaging computer hard disks, or deploying new VM instances or AMI, using a "golden image" that has an already-activated Deep Security Agent. It ensures that each computer has a unique agent GUID, despite being deployed by copying the same software image.

Clones are detected after the initial activation, during their first heartbeat. If the same agent GUID is being used on different computers, the manager detects the clones and reactivates those computers.

Note: If you disable this option, clones will *not* be automatically reactivated. You'll need to activate them either manually through the manager or using an activation script.

This setting only applies to AWS instances, Azure virtual machines (VMs), Google Cloud Platform (GCP) VMs, or VMware VMs that you added using **Computers > Add Account**.

- **Reactivate unknown Agents:** Reactivate deleted (but previously activated) computers as new computers if they connect again. The original computer's assigned policies or rules will not be assigned to the computer again by default. You should assign it again manually or use a tool such as an [event-based task](#) to assign it automatically. This setting is useful together with [inactive agent cleanup](#): any accidentally removed computers can automatically re-activate. See also "[Automate offline computer removal with inactive agent cleanup](#)" on page 1470.

Previously known agents are detected after the initial activation, during their next heartbeat. If a heartbeat has an agent GUID (indicating prior activation) but its computer is not currently listed on **Computers**, the manager reactivates the computer.

Note: Previous event messages will still link to the old computer object, not this new one.

- **Agent activation token:** Optional. Agent activation secret. If specified, agents must provide the same value when activating.

Note: If Deep Security Manager is multi-tenant, this setting applies only to the primary tenant.

To configure this, you can use the `token` parameter in the agent activation script such as:

```
/opt/ds_agent/dsa_control -a dsm://172.16.0.5:4120/ "token:secret"
```

Agent Upgrade

Automatically upgrade agents on activation: During activation, upgrade Deep Security Agent to the latest software version that's compatible with Deep Security Manager. Linux computers only. See also "[Automatically upgrade agents on activation](#)" on page 1462.

Inactive Agent Cleanup

If you have many offline computers (that is, computers not communicating with Deep Security Manager), you can automatically remove them from **Computers** using inactive agent cleanup. This setting is useful together with [reactivating currently unknown agents](#). See also "[Automate offline computer removal with inactive agent cleanup](#)" on page 1470.

Delete Agents that have been inactive for: How much time a computer must be inactive in order to be removed.

Data Privacy

Allow packet data capture in network events: This setting determines whether the agent captures and sends packet data to Deep Security Manager as part of Intrusion Prevention and Firewall events. The options for this setting are:

- **Yes (excluding encrypted traffic):** This is the default option. All unencrypted packet data is sent to Deep Security Manager.
- **Yes (all traffic):** All packet data is sent to Deep Security Manager, including encrypted packet data. The resource requirements for capture of packet data on encrypted connections is higher than for unencrypted connections. If you select this option and encounter problems with performance on your workloads, consider switching to the option that excludes encrypted traffic.
- **No:** Packet data is not captured or transmitted from the agent to Deep Security Manager. Customers in regulated environments or who are concerned about the transmission of network content to Deep Security Manager can disable this setting. For more information about data transmitted to Deep Security Manager, see the [Deep Security Data Collection Notice](#).

Note: This feature is supported with Deep Security Agent 12.5.0.1001 or later.

Agentless vCloud Protection

Allow Appliance protection of vCloud VMs: Allow virtual machines in VMware vCloud to be protected by Deep Security Virtual Appliance instead of (or in addition to) Deep Security Agent. If Deep Security Manager is multi-tenant, tenants configure the security policies of those VMs.

Deep Security notifier

The Deep Security notifier is a Windows taskbar application that communicates the state of the Deep Security Agent and Deep Security Relay to client machines. The notifier displays popup user notifications in the taskbar notification area when the Deep Security Agent blocks malware or prevents access to malicious web pages.

The notifier has a small footprint on the client machine, requiring less than 1MB of disk space and 1MB of memory. When the notifier is running, the notifier icon () appears in the taskbar. The notifier is automatically installed by default with the Deep Security Agent on Windows computers. Use the **Administration > Updates > Software > Local** page to import the latest version for distribution and upgrades.

On computers running a relay-enabled agent, the notifier displays the components that are being distributed to agents or appliances, *not* which components are in effect on the local computer.

A standalone version of the notifier can be downloaded and installed on virtual machines that are receiving protection from a Deep Security Virtual Appliance. See "[Deploy Deep Security notifier](#)" on page 630.

Note: On VMs protected by a virtual appliance, the anti-malware module must be licensed and enabled on the VM for the Deep Security Notifier to display information.

How the notifier works

When malware is detected or a malicious site is blocked, the Deep Security Agent sends a message to the notifier, which displays a popup message in the notification area of the taskbar.

If malware is detected, the notification area displays a pop-up message similar to the following:

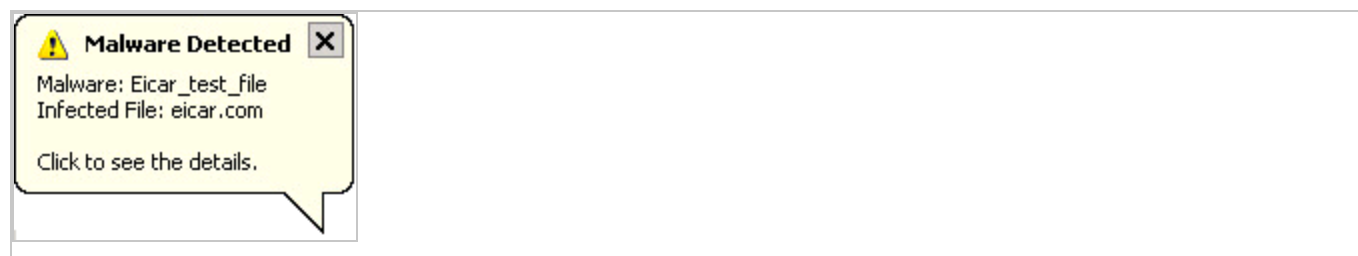

If the user clicks on the message, a dialog with detailed information about anti-malware events is displayed:

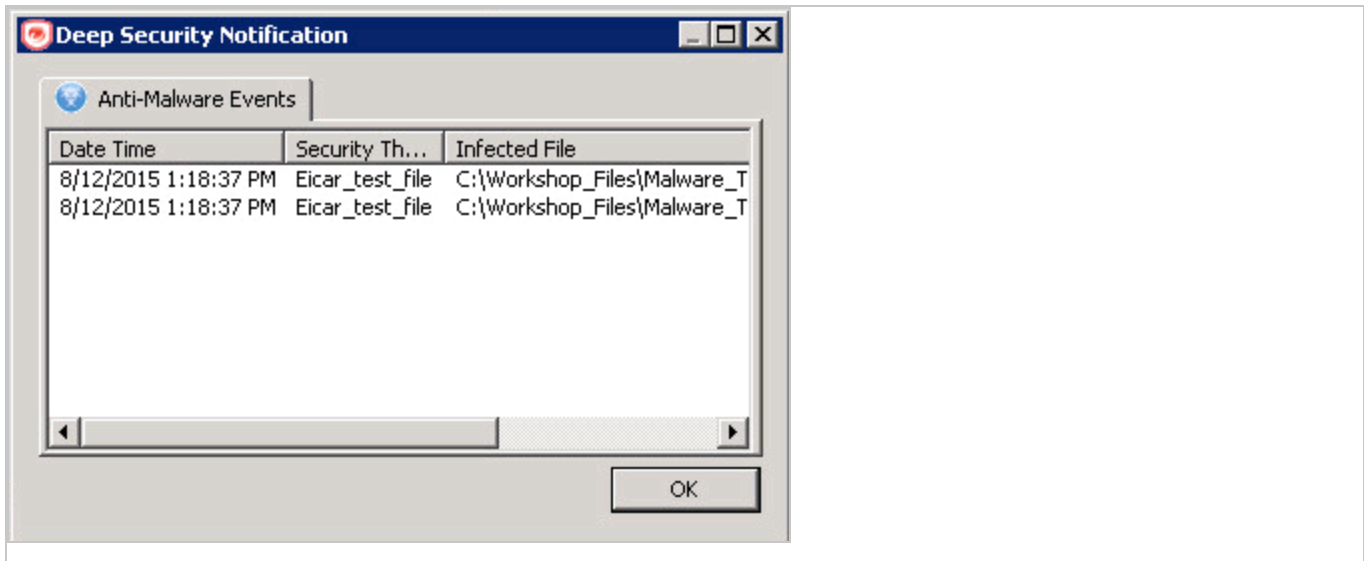

When a malicious web page is blocked, the notification area displays a pop-up message similar to the following:

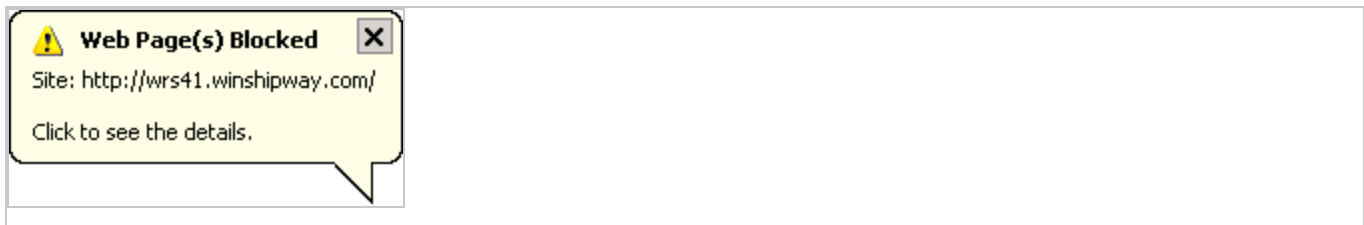

If the user clicks on the message, a dialog with detailed information about web reputation events is displayed:

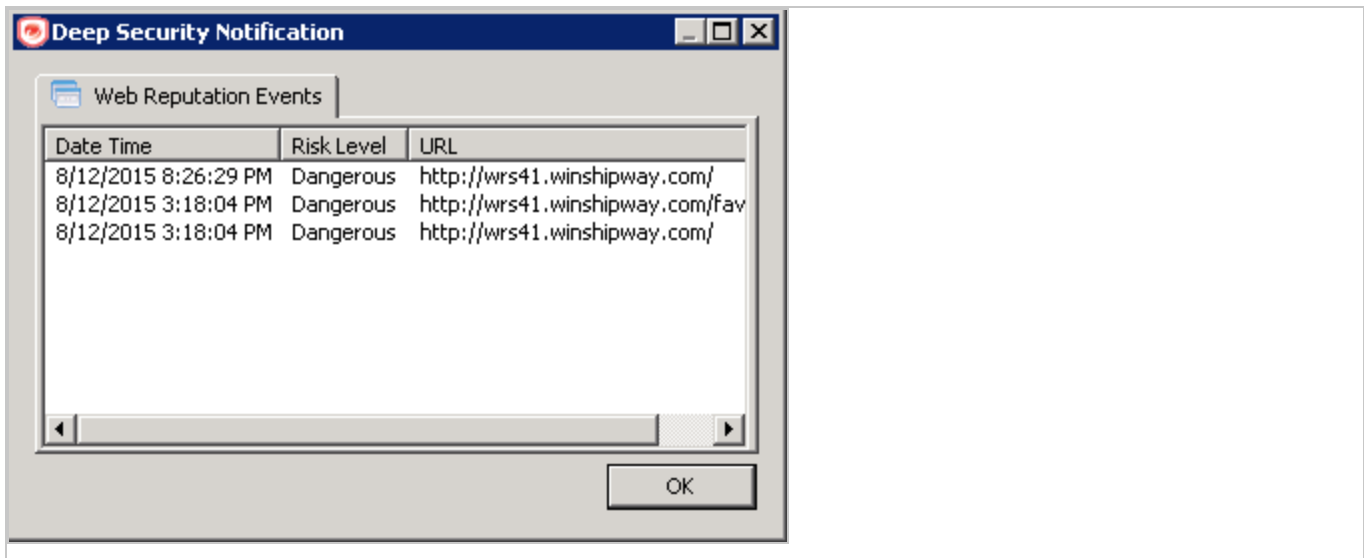

The notifier also provides a console utility for viewing the current protection status and component information, including pattern versions. The console utility allows the user to turn on and off the pop-up notifications and access detailed event information.

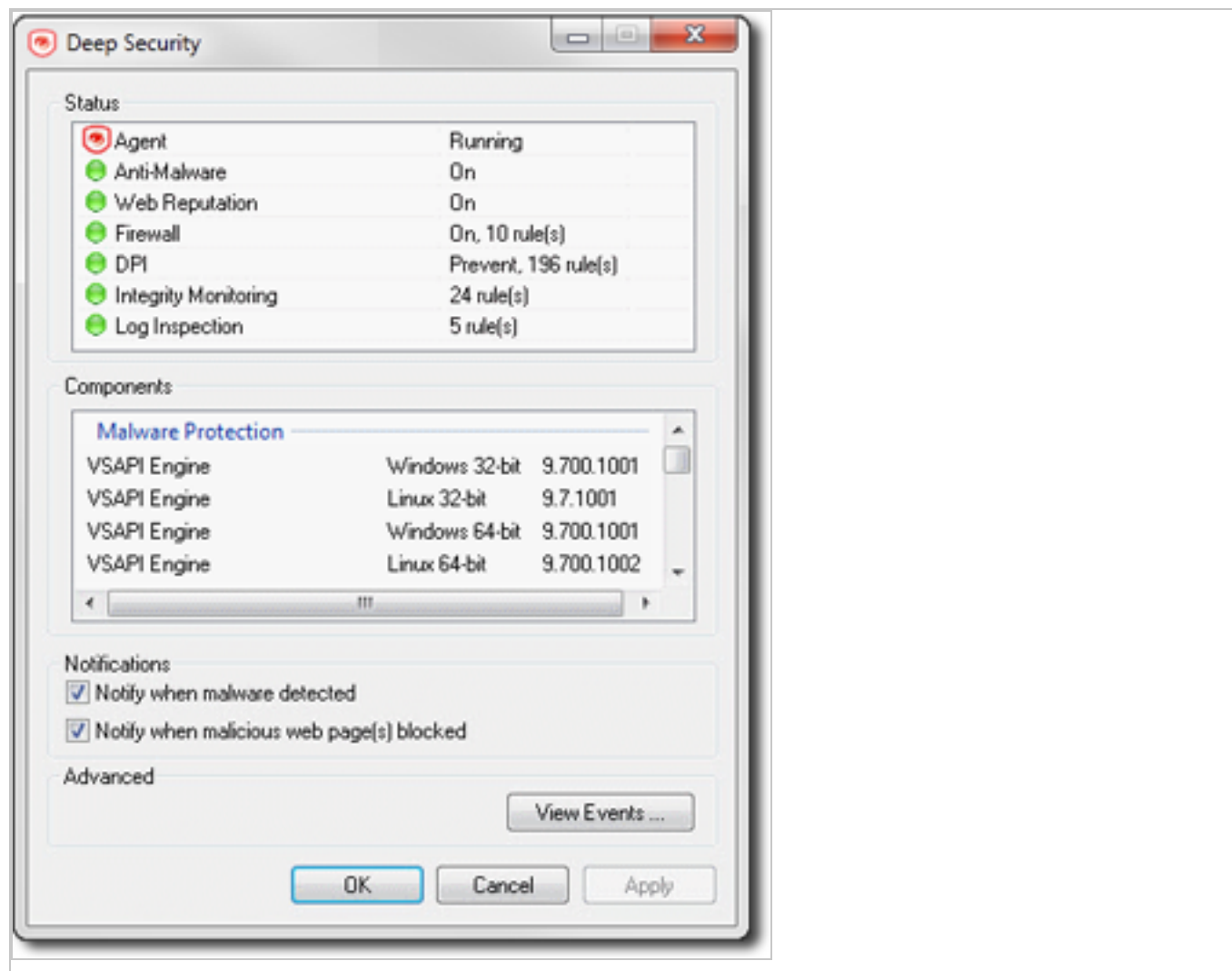

You can also turn off pop-up notifications for certain computers or for computers that are assigned a particular policy by going to the Deep Security Manager **Computer/Policy editor > Settings > General** and settings **Suppress all pop-up notifications on host** to **Yes**. The messages still appear as alerts or events in Deep Security Manager.

When the notifier is running on a computer hosting Deep Security Relay, the notifier's display shows the components being distributed by the relay and not the components that in effect on the computer.

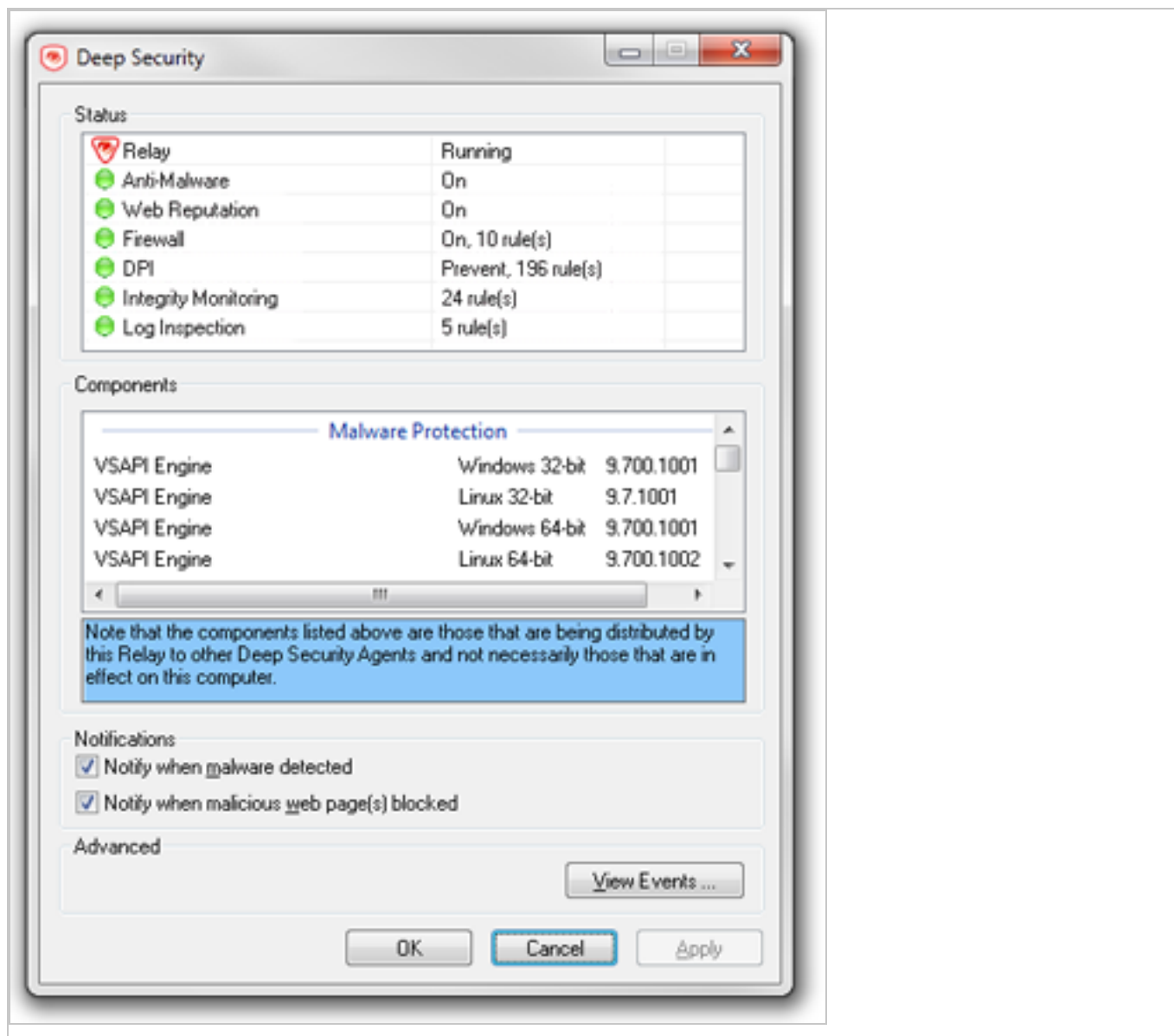

When the notifier is running on a computer hosting Deep Security Scanner, the notifier shows that the scanner feature is enabled and the computer cannot be a relay.

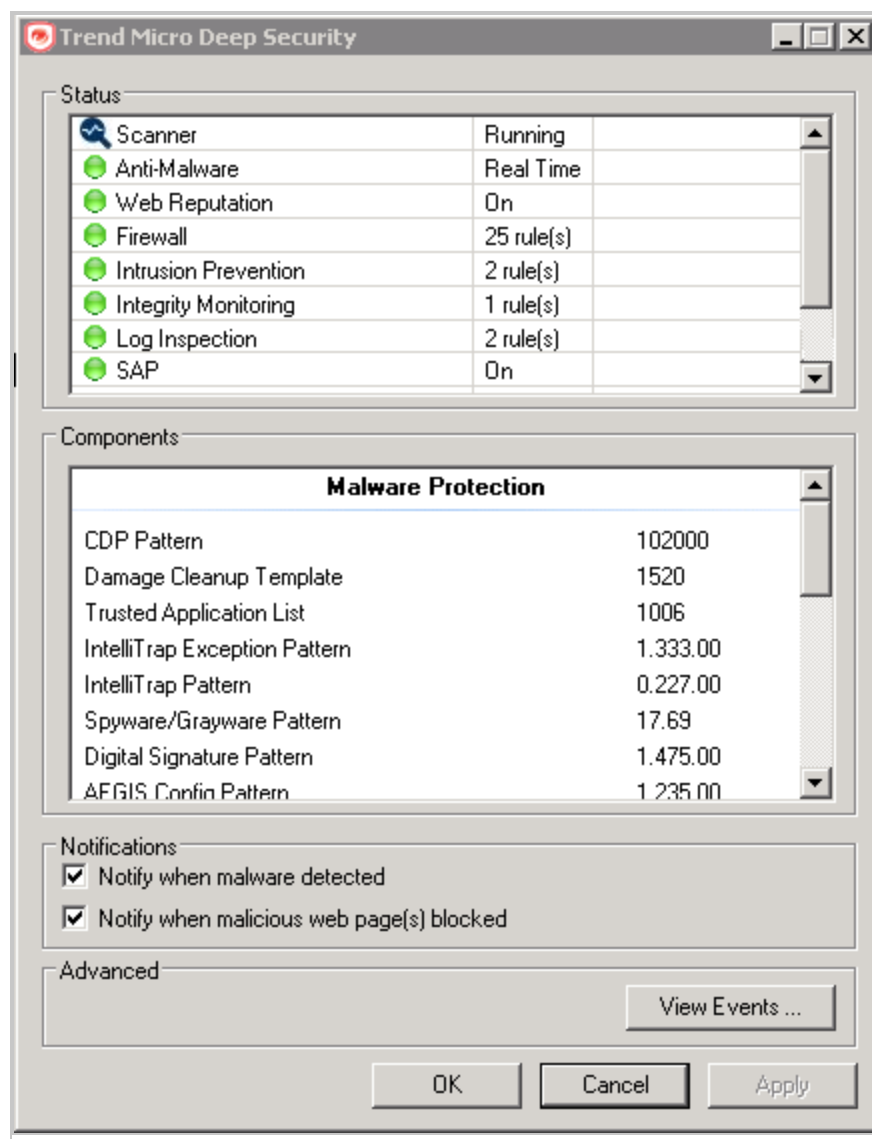

Trigger a manual scan on Windows OS

If an agent is enabled to trigger a manual scan in the notifier application, the notifier console includes a panel titled **Scan**. The notifier uses the scan configuration assigned from the **Computer** editor or the **Policy** editor, in the editor's Anti-Malware tab, in the General horizontal tab, in the **Manual Scan** section. For details, see [Create or edit a malware scan configuration](#).

A scan cannot be triggered:

- When the agent is being upgraded.
- When there is an ongoing server-side scan already taking place.

- If the scan configuration is empty.

To start a manual scan by the agent on Windows OS:

1. In the **Scan** panel, click **Scan**.
2. Select the folders to scan and click **Scan**:
 - For a Full Scan, select **This PC** to start a scan of all files.
 - For a Custom Scan, select one or more files or folders to start a scan.

Once the scan is completed, the Scan Result displays the number of detected malware items. To view details of these items, click **View Events** in the notifier's **Advanced** panel.

An ongoing scan is halted if it has been triggered on a computer that is not available. For example, the user logs out of the computer after the scan has been started.

Manage users

Add and manage users

Deep Security has users, roles, and contacts that can be created and managed under **Administration > User Management**.

- **Users** are Deep Security account holders who can sign in to the Deep Security Manager with a unique user name and password. You can ["Synchronize users with an Active Directory" below](#) or ["Add or edit an individual user" on the next page](#)
- **Roles** are a collection of permissions to view data and perform operations within Deep Security Manager. Each user is assigned a role. See ["Define roles for users" on page 1488](#).
- **Contacts** do not have a user account and cannot sign in to Deep Security Manager but they can be designated as the recipients of email notifications and scheduled reports. See ["Add users who can only receive reports" on page 1504](#).

Synchronize users with an Active Directory

If you use Active Directory to manage users, you can synchronize Deep Security with the Active Directory to populate the user list. Users can then sign into Deep Security Manager using the password stored in the directory.

To successfully import an Active Directory user account into Deep Security as a Deep Security user or contact, the Active Directory user account must have a **userPrincipalName** attribute value. The **userPrincipalName** attribute corresponds to an Active Directory account holder's User logon name.

If you are using Deep Security in FIPS mode, you must import the Active Directory's SSL certificate before synchronizing with the Directory. See ["Manage trusted certificates" on page 1603](#).

1. In Deep Security Manager go to **Administration > User Management > Users**.
2. Click **Synchronize with Directory** to open the **Synchronize with Directory** dialog.
3. Type the address of the directory server.
4. Enter your access credentials, which should at a minimum have the Active Directory READ permission. Note that members of the Domain User group have READ permissions by default.
5. Click **Next** to trigger an attempt to connect to the Active Directory.
6. Use the next dialog to enter an Active Directory group name or part of a group name into the search field, and then press enter. Move the group to the **Groups to synchronize** pane using the **>>** button.

The imported list of users are locked out of the Deep Security Manager by default. You have to modify their properties to allow them to sign in to the Deep Security Manager.

If you delete a user from Deep Security Manager who was added as a result of synchronizing with an Active Directory and then resynchronize with the directory, the user will reappear in your user list if they are still in the Active Directory.

Add or edit an individual user

1. In Deep Security Manager go to **Administration > User Management > Users**.
2. Click **New** to add a new user or double-click an existing user account to edit its settings.
3. Specify the general properties for the user, including:
 - **Username:** The username that the user will enter on the Deep Security Manager login screen.
 - **Password and Confirm Password:** Note the password requirements listed in the dialog box. You can password requirements in the user security settings (see ["Enforce user password rules" on page 1597](#)).
 - **Name:** (Optional) The name of the account holder.
 - **Description:** (Optional) A description of the account.

- **Role:** Use the list to assign a predefined role to this user. You can also assign a role to a user from the Users list, by right-clicking a user and then clicking **Assign roles**.

Deep Security Manager is preconfigured with two roles: Full Access and Auditor. The Full Access role grants users all possible privileges for managing the Deep Security system, such as creating, editing, and deleting computers, computer groups, policies, rules, and so on. The auditor role gives users the ability to view all of the information in the Deep Security system but not the ability to make any modifications except to their personal settings (password, contact information, view preferences, and so on). Roles with various levels of system access rights can be created and modified on the Roles page or by selecting **New** in the **Role** list.

- **Language:** The language that will be used in the interface when this user logs in.
 - **Time zone:** Time zone where the user is located. This time zone is used when displaying dates and times in the Deep Security Manager.
 - **Time format:** Time format used to display time in the Deep Security Manager. You can use 12-hour or 24-hour format.
 - **Password never expires:** When this option is selected, the user's password will never expire. Otherwise, it will expire as specified in the user security settings (see ["Enforce user password rules" on page 1597](#)).
4. If you want to enable multi-factor authentication (MFA), click **Enable MFA**. If MFA is already enabled for this user, you can select **Disable MFA** to disable it. For details, see ["Set up multi-factor authentication" on page 1599](#).
 5. Click the **Contact information** tab and enter any contact information that you have for the user and also indicate if they are your primary contact or not. You can also check the **Receive Alert Emails** check box to include this user in the list of users who receive email notifications when alerts are triggered.
 6. You can also edit the settings on the **Settings** tab. However, increasing some of these values will affect Deep Security Manager performance. If you make changes and aren't happy with the results, you can click **Reset to Default Settings** (at the bottom of the tab) to reset all settings on this page to their default values:

Module

- **Hide Unlicensed Modules:** This setting determines whether unlicensed modules will be hidden rather than simply grayed out for this User. This option can be set globally on the **Administration > System Settings > Advanced** tab.

Refresh Rate

- **Status Bar:** This setting determines how often the status bar of the Deep Security Manager refreshes during various operations such as discovering or scanning computers.
- **Alerts List/Summary:** How often to refresh the data on the **Alerts** page in the **List** view or **Summary** view.
- **Computers List:** How often to refresh the data on the **Computers** page.

The **Last Successful Update** column value is not recalculated unless the page is manually reloaded.

- **Computer Details:** The frequency with which an individual computer's property page refreshes itself with the latest information (if required).

List Views

- **Remember last Tag filter on each page:** Events pages let you filter displayed events by tags. This List Views setting determines if the Tag filter setting is retained when you navigate away from and return to an **Events** page.
- **Remember last Time filter on each page:** Events pages let you filter displayed events by time period and computers. These List Views settings determine if the Period and Computer filter settings are retained when you navigate away from and return to an **Events** page.
- **Remember last Computer filter on each page:** Events pages let you filter displayed events by time period and computers. These List Views settings determine if the Period and Computer filter settings are retained when you navigate away from and return to an **Events** page.
- **Remember last Advanced Search on each page:** If you have performed an Advanced Search on an **Events** page, this setting determines whether or not the search results are kept if you navigate away and then return to the page.
- **Number of items to show on a single page:** Screens that display lists of items display a certain number of items per Page. To view the next page, you must use the pagination controls. Use this setting to change the number of list items displayed per page.
- **Maximum number of items to retrieve from database:** This setting limits the number of items that can be retrieved from the database for display. This prevents the possibility of Deep Security Manager getting bogged down trying to display an excessive number of results from a database query. If a query produces more than this many results, a

message appears at the top of the display informing you that only a portion of the results are being displayed.

Note: Increasing these values affects the Deep Security Manager performance.

Reports

- **Enable PDF Encryption:** When this option is selected, reports exported in PDF format are password-protected with the **Report Password**.

Change a user's password

To change a user's password, click **Administration > User Management > Users**, right-click the user, and click **Set Password**. You will be prompted for the old password as well as the new password.

Lock out a user or reset a lockout

If a user enters the wrong password too many times when trying to sign in, they will be locked out automatically. If you have resolved the situation and want to allow the user the log in, see ["Unlock a locked out user name" on page 1506](#).

View system events associated with a user

To see any system events associated with a user, click **Administration > User Management > Users**, right-click the user, and click **View System Events**.

Delete a user

To remove a user account from Deep Security Manager, click **Administration > User Management > Users**, click the user, and then click **Delete**.

If you delete a user from Deep Security Manager who was added as a result of synchronizing with an Active Directory and then resynchronize with the directory, the user will reappear in your user list if they are still in the Active Directory.

Define roles for users

Deep Security uses role-based access control (RBAC) to restrict user permissions to parts of Deep Security. Access rights and editing privileges are attached to roles and not to users. Once you have installed Deep Security Manager, you should create individual accounts for each user and assign each user a role that will restrict their activities to all but those necessary for the completion of their duties. To change the access rights and editing privileges of an individual user, you must assign a different role to the user or edit the role.

The access that roles have to computers and policies can be restricted to subsets of computers and policies. For example, users can be permitted to view all existing computers, but only permitted to modify those in a particular group.

Deep Security comes preconfigured with two roles:

- **Full Access:** The full access role grants the user all possible privileges in terms of managing the Deep Security system including creating, editing, and deleting computers, computer groups, policies, rules, malware scan configurations, and others.
- **Auditor:** The auditor role gives the user the ability to view all the information in the Deep Security system but without the ability to make any modifications except to their own personal settings, such as password, contact information, dashboard layout preferences, and others.

Note: Depending on the level of access granted, controls in Deep Security Manager will be either visible and changeable, visible but disabled, or hidden. For a list of the rights granted in the preconfigured roles, as well as the default rights settings when creating a new role, see ["Default settings for full access, auditor, and new roles" on page 1496](#).

You can create new roles that can restrict users from editing or even seeing Deep Security objects such as specific computers, the properties of security rules, or the system settings.

Before creating user accounts, identify the roles that your users will take and itemize what Deep Security objects those roles will require access to and what the nature of that access will be (viewing, editing, creating, and so on). Once you have created your roles, you can then begin creating user accounts and assigning them specific roles.

Note: Do not create a new role by duplicating and then modifying the full access role. To ensure that a new role only grants the rights you intend, create the new role by clicking **New** in the toolbar. The rights for a new role are set at the most restrictive settings by default. You can

then proceed to grant only the rights that are required. If you duplicate the full access role and then apply restrictions, you risk granting some rights that you did not intend.

Clicking **New** (👤) or **Properties** (📄) displays the **Role properties window** with six tabs (**General**, **Computer Rights**, **Policy Rights**, **User Rights**, **Other Rights**, and **Assigned To**).

Add or edit a role

1. In Deep Security Manager, navigate to **Administration > User Management > Roles**.
2. Click **New** to add a new role or double-click an existing role to modify its settings.
3. Specify the general properties for the role, including the following:
 - **Name:** The name of the role, which will appear on the **Roles** page and in the list of available roles when adding a user.
 - **Description:** A description of the role (optional).
 - **Access Type:** Select whether users with this role will have access to Deep Security Manager, the Deep Security Manager Web service API (applies to the legacy SOAP and REST APIs), or both.

Note: To enable the legacy SOAP and REST Web service APIs, go to **Administration > System Settings > Advanced > SOAP Web Service API**.

- **Migrate to Trend Cloud One - Endpoint & Workload Security:** Select whether users with this role will have access to Workload Security Link, process migration tasks, or both.
4. Use the **Computer Rights** pane to confer viewing, editing, deleting, warnings and errors clearing, alerts dismissal, event tagging rights to users in a role. These rights can apply to all computers and computer groups or they can be restricted to specific computers. To restrict access, select the type of action the users are allowed to perform. If the action applies to **Selected Computers** only, then select the computer groups and computers to which users in this role will have access.

These rights restrictions affect not only the user's access to computers in Deep Security Manager, but also what information is visible, including events and alerts. In addition, email notifications will only be sent if they relate to data to which the user has access rights.

Note that when the rights to clear warnings and errors are granted, the role is considered as an editor, not a viewer.

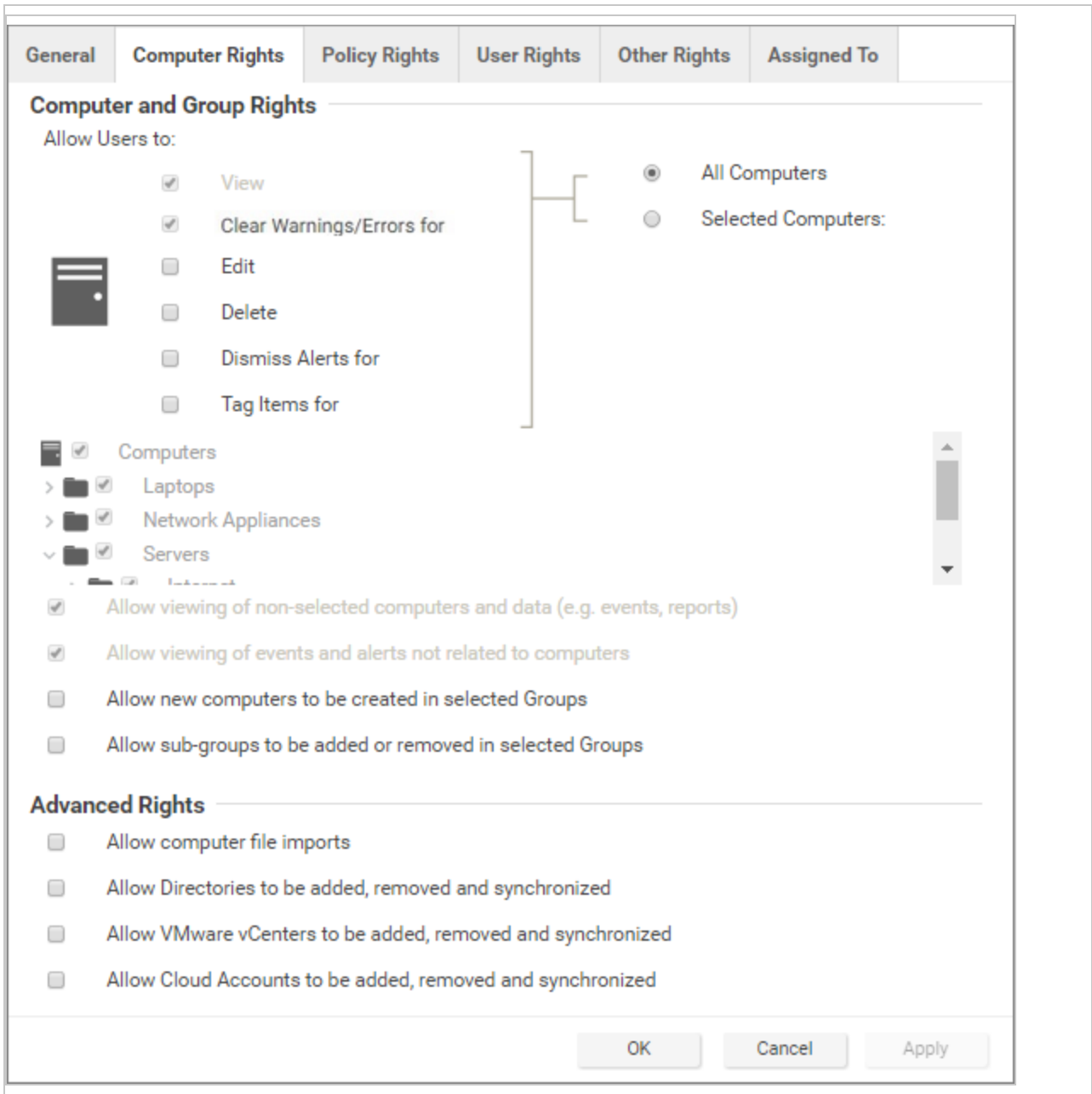

Four basic options are available:

- **Allow viewing of non-selected computers and data:** If users in this role have restricted edit, delete, or dismiss-alerts rights, you can still allow them to view but not change information about other computers by checking this box.

- **Allow viewing of events and alerts not related to computers:** Set this option to allow users in this role to view non-computer-related information (for example, system events, like users being locked out, new firewall rules being created, IP Lists being deleted, and so on)

Note: The previous two settings affect the data that users have access to. Although the ability of a user to make changes to computers have been restricted, these two settings control whether they can see information relating to computers they don't otherwise have access to. This includes receiving email notifications related to those computers.

- **Allow new computers to be created in selected Groups:** Set this option to allow users in this role to create new computers in the computer groups they have access to.
- **Allow sub-groups to be added/removed in selected Groups:** Set this option to allow users in this role to create and delete subgroups within the computer groups to which they have access.

You can also enable these in the **Advanced Rights** section:

- **Allow computer file imports:** Allow Users in this Role to import computers using files created using the Deep Security Manager's **Computer Export** option.
 - **Allow Directories to be added, removed and synchronized:** Allow Users in this Role to add, remove, and synchronize computers that are being managed using an LDAP-based directory like MS Active Directory.
 - **Allow VMware vCenters to be added, removed and synchronized:** Allow Users in this Role to add, remove and synchronize VMware vCenters.
 - **Allow Cloud Providers to be added, removed, and synchronized:** Allow Users in this Role to add, remove, and synchronize Cloud Providers.
5. Use the **Policy Rights** tab to confer viewing, editing, and deleting rights to users in a role. These rights can apply to all policies or they can be restricted to only certain policies. If you wish to restrict access, click **Selected Policies** and put a check mark next to the policies that users in this role will have access to.

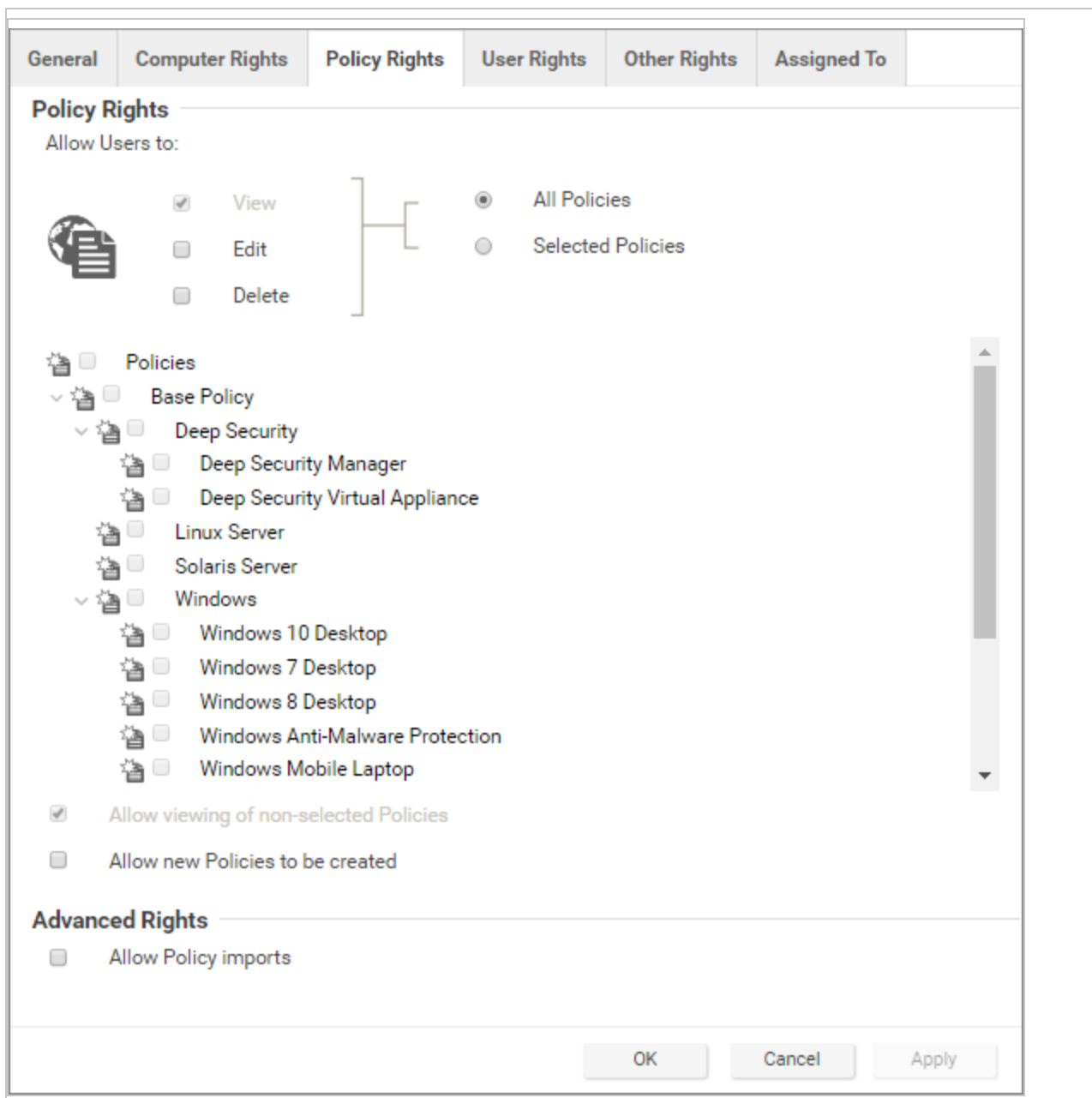

When you allow rights to a policy that has "child" policies, users automatically get rights to the child policies as well.

Two basic options are available:

- **Allow viewing of non-selected Policies:** If users in this role have restricted edit or delete rights, you can still allow them to view but not change information about other policies by checking this box.

- **Allow new Policies to be created:** Set this option to allow users in this role to create new policies.

You can also enabled this in the Advanced Rights section:

- **Allow Policy imports:** Allow users in this role to import policies using files created with the Deep Security Manager **Export** option on the **Policies** tab.
6. The options on the **User Rights** tab allow you to define permissions for administrator accounts.

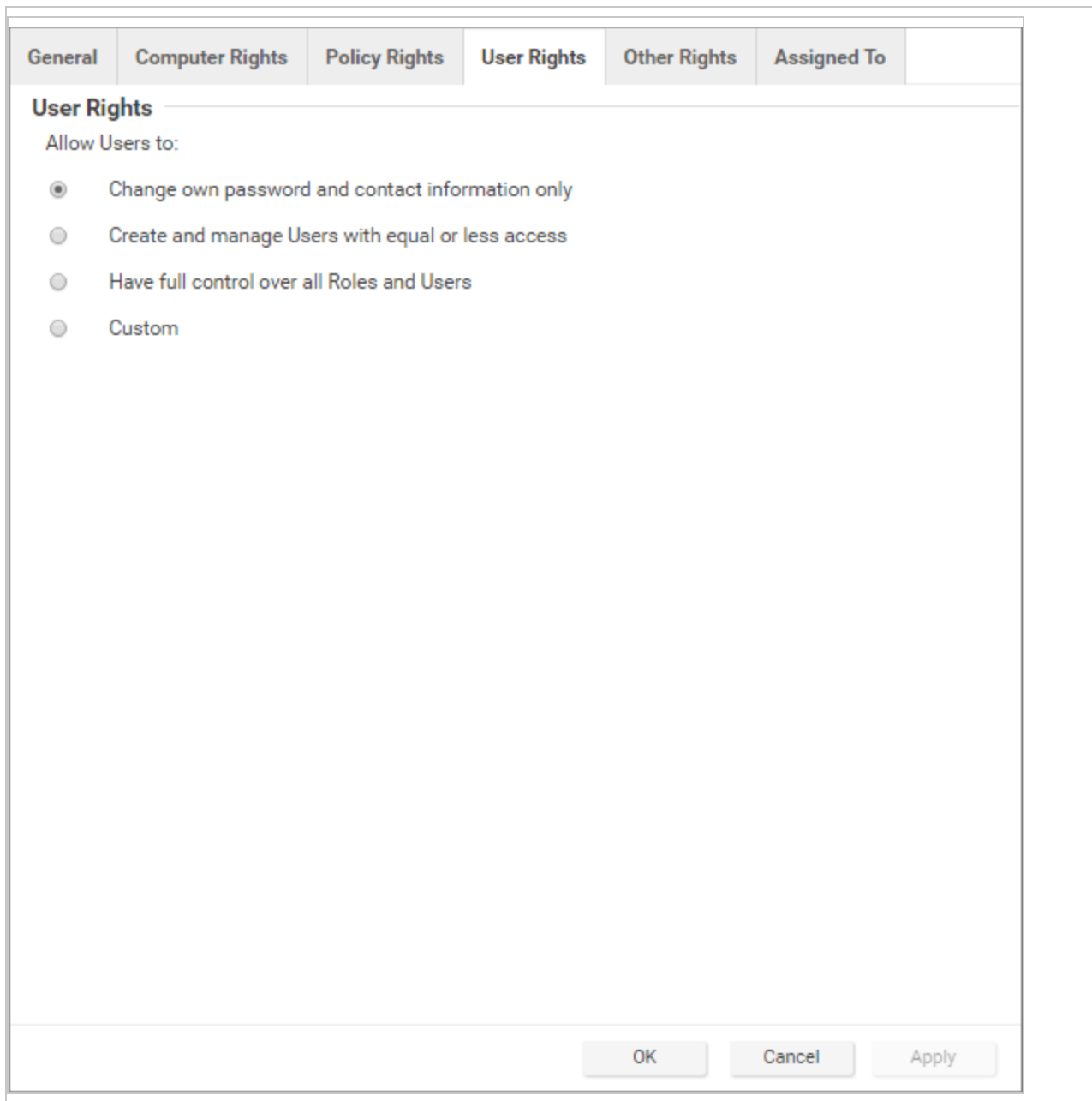

- **Change own password and contact information only:** Users in this role can change their own password and contact information only.
- **Create and manage Users with equal or less access:** Users in this role can create and manage any users who do not have any privileges greater than theirs. If there is even a single privilege that exceeds those of the users with this role, the users with this role will not be able to create or manage them.
- **Have full control over all Roles and Users:** Gives users in this role the ability to create and edit and users or roles without restrictions. Be careful when using this option. If you assign it to a role, you may give a user with otherwise restricted privileges the ability to create and then sign in as a user with full unrestricted access to all aspects of the Deep Security Manager.
- **Custom:** You can further restrict the ability of a user to view, create, edit, or delete users and roles by selecting **Custom** and using the options in the **Custom Rights** section. Some options may be restricted for certain users if the **Can only manipulate Users with equal or lesser rights** option is selected.

The **Can only manipulate Users with equal or lesser rights** option limits the authority of users in this role. They will only be able to effect changes to users that have equal or lesser rights than themselves. Users in this Role will not be able to create, edit, or delete roles. Selecting this option also places restrictions on some of the options in the **Custom Rights** section:

- **Can Create New Users:** Can only create users with equal or lesser rights.
 - **Can Edit User Properties:** Can only edit a user (or set or reset password) with equal or lesser rights.
 - **Can Delete Users:** Can only delete users with equal or lesser rights.
7. The **Other Rights** tab enables you to restrict roles' permissions so that they can only access specific Deep Security features, and sometimes specific actions with those features. This can be useful if, for example, you have a team of administrators, and you want to make sure that they don't accidentally overwrite each others' work. By default, roles are **View Only** or **Hide** for each feature. To allow to full control or customized access,

select **Custom** from the list.

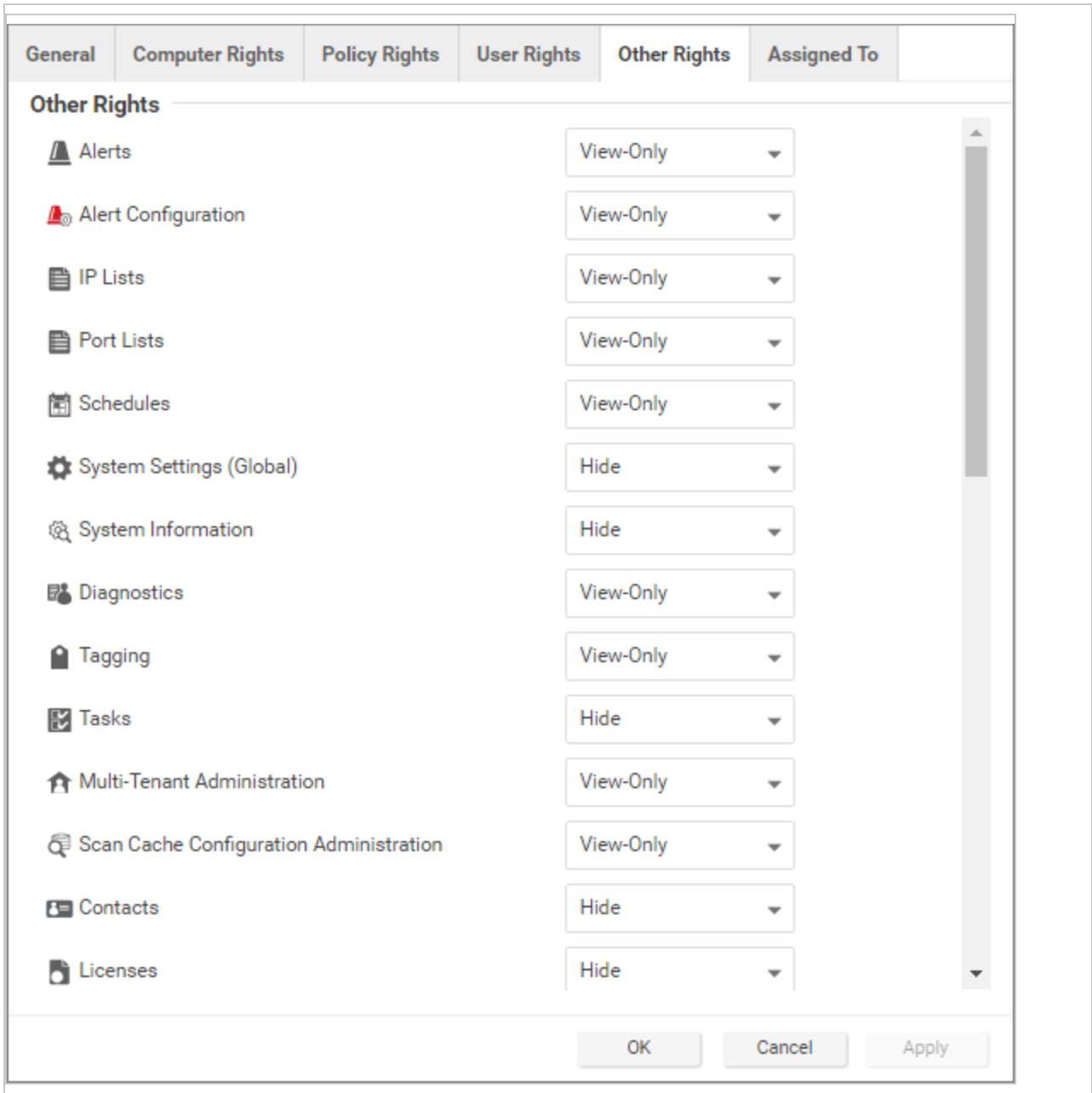

8. The **Assigned To** tab displays a list of the users who have been assigned this role. If you want to test that roles are working correctly, sign in as a newly created user and verify the functionality.

Default settings for full access, auditor, and new roles

The following table identifies the default rights settings for the full access role and the auditor role. Also listed are the rights settings that are in place when creating a new role by clicking New in the toolbar on the Roles page.

RIGHTS	SETTINGS BY ROLE		
	Full Access Role	Auditor Role	New Role Defaults
General	Full Access Role	Auditor Role	New Role Defaults
Access to DSM User Interface	Allowed	Allowed	Allowed
Access to Web Service API	Allowed	Allowed	Not allowed
Computer Rights	Full Access Role	Auditor Role	New Role Defaults
View	Allowed, All Computers	Allowed, All Computers	Allowed, All Computers
Clear Warnings/Errors for	Allowed, All Computers,	Not allowed, All Computers	Not allowed, All Computers
Edit	Allowed, All Computers	Not allowed, All Computers	Not allowed, All Computers
Delete	Allowed, All Computers	Not allowed, All Computers	Not allowed, All Computers
Dismiss Alerts for	Allowed, All Computers	Not allowed, All Computers	Not allowed, All Computers
Tag Items for	Allowed, All Computers	Not	Not

RIGHTS	SETTINGS BY ROLE		
		allowed, All Computers	allowed, All Computers
Allow viewing of non-selected computers and data (e.g. events, reports)	Allowed	Allowed	Allowed, All Computers
Allow viewing of events and alerts not related to computers	Allowed	Allowed	Allowed, All Computers
Allow new computers to be created in selected Groups	Allowed	Not allowed	Not allowed
Allow sub-groups to be added or removed in selected Groups	Allowed	Not allowed	Not allowed
Allow computer file imports	Allowed	Not allowed	Not allowed
Allow Cloud Accounts to be added, removed and synchronized	Allowed	Not allowed	Not allowed
Policy Rights	Full Access Role	Auditor Role	New Role Defaults
View	Allowed, All Policies	Allowed, All Policies	Allowed, All Policies
Edit	Allowed, All Policies	Not allowed, All	Not allowed, All

RIGHTS	SETTINGS BY ROLE		
		Policies	Policies
Delete	Allowed, All Policies	Not allowed, All Policies	Not allowed, All Policies
View non-selected Policies	Allowed	Allowed	Allowed
Create new Policies	Allowed	Not allowed	Not allowed
Import Policies	Allowed	Not allowed	Not allowed
User Rights (See note on User rights below)	Full Access Role	Auditor Role	New Role Defaults
View Users	Allowed	Allowed	Not allowed
Create Users	Allowed	Not allowed	Not allowed
Edit User Properties	Allowed	Not allowed	Not allowed
Delete Users	Allowed	Not allowed	Not allowed
View Roles	Allowed	Allowed	Not allowed
Create Roles	Allowed	Not allowed	Not allowed
Edit Role Properties	Allowed	Not allowed	Not allowed

RIGHTS	SETTINGS BY ROLE		
Delete Roles	Allowed	Not allowed	Not allowed
Delegate Authority	Allowed	Not allowed	Not allowed
Other Rights	Full Access Role	Auditor Role	New Role Defaults
Alerts	Full (Can Dismiss Global Alerts)	View-Only	View-Only
Alert Configuration	Full (Can Edit Alert Configurations)	View-Only	View-Only
IP Lists	Full (Can Create, Edit, Delete)	View-Only	View-Only
Port Lists	Full (Can Create, Edit, Delete)	View-Only	View-Only
Schedules	Full (Can Create, Edit, Delete)	View-Only	View-Only
System Settings (Global)	Full (Can View, Edit System Settings (Global))	Hide	Hide
Diagnostics	Full (Can Create Diagnostic Packages)	View-Only	View-Only
Tagging	Full (Can Tag (Items not belonging to Computers), Can Delete Tags, Can Update Non-Owned Auto-Tag Rules, Can Run Non-Owned Auto-Tag Rules, Can Delete Non-Owned Auto-Tag Rules)	View-Only	View-Only
Tasks	Full (Can View, Add, Edit, Delete Tasks, Execute Tasks)	Hide	Hide
Multi-Tenant Administration	Full	Hide	Hide
Scan Cache Configuration Administration	Full	View-Only	View-Only

RIGHTS	SETTINGS BY ROLE		
Contacts	Full (Can View, Create, Edit, Delete Contacts)	Hide	Hide
Licenses	Full (Can View, Change License)	Hide	Hide
Updates	Full (Can Add, Edit, Delete Software; Can View Update For Components; Can Download, Import, Apply Update Components; Can Delete Deep Security Rule Updates)	Hide	Hide
Asset Values	Full (Can Create, Edit, Delete Asset Values)	View-Only	View-Only
Certificates	Full (Can Create, Delete SSL Certificates)	View-Only	View-Only
Relay Groups	Full	View-Only	View-Only
Proxy	Full	View-Only	View-Only
SAML Identity Providers	Full	Hide	Hide
Malware Scan Configuration	Full (Can Create, Edit, Delete Malware Scan Configuration)	View-Only	View-Only
Quarantined File	Full (Can Delete, Download Quarantined File)	View-Only	View-Only
Web Reputation Configuration	Full	View-Only	View-Only
Directory Lists	Full (Can Create, Edit, Delete)	View-Only	View-Only
File Lists	Full (Can Create, Edit, Delete)	View-Only	View-Only
File Extension Lists	Full (Can Create, Edit, Delete)	View-Only	View-Only
Firewall Rules	Full (Can Create, Edit, Delete Firewall Rules)	View-Only	View-Only

RIGHTS	SETTINGS BY ROLE		
Firewall Stateful Configurations	Full (Can Create, Edit, Delete Firewall Stateful Configurations)	View-Only	View-Only
Intrusion Prevention Rules	Full (Can Create, Edit, Delete)	View-Only	View-Only
Application Types	Full (Can Create, Edit, Delete)	View-Only	View-Only
MAC Lists	Full (Can Create, Edit, Delete)	View-Only	View-Only
Contexts	Full (Can Create, Edit, Delete)	View-Only	View-Only
Integrity Monitoring Rules	Full (Can Create, Edit, Delete)	View-Only	View-Only
Log Inspection Rules	Full (Can Create, Edit, Delete)	View-Only	View-Only
Log Inspection Decoders	Full (Can Create, Edit, Delete)	View-Only	View-Only
Application Control Rulesets	Full (Can Create, View, Edit, or Delete Application Control rulesets)	Hide	Hide
Application Control Rule	Full (Can Create, View, Edit, or Delete Application Control rules)	Hide	Hide
Application Control Unrecognized Software	Full (Can View or Allow/Block unrecognized software)	Hide	Hide
Application Control Software Inventory	Full (Can Create, View, or Delete software inventory)	Hide	Hide

The custom settings corresponding to the **Change own password and contact information only** option are listed in the following table:

Custom settings corresponding to "Change own password and contact information only" option
Users

Custom settings corresponding to "Change own password and contact information only" option	
Can View Users	Not allowed
Can Create New Users	Not allowed
Can Edit User Properties (User can always edit select properties of own account)	Not allowed
Can Delete Users	Not allowed
Roles	
Can View Roles	Not allowed
Can Create New Roles	Not allowed
Can Edit Role Properties (Warning: conferring this right will let Users with this Role edit their own rights)	Not allowed
Can Delete Roles	Not allowed
Delegate Authority	
Can only manipulate Users with equal or lesser rights	Not allowed

The custom settings corresponding to the **Create and manage Users with equal or less access** option are listed in the following table:

Custom settings corresponding to "Create and manage Users with equal or less access" option	
Users	
Can View Users	Allowed
Can Create New Users	Allowed
Can Edit User Properties (User can always edit select properties of own account)	Allowed

Custom settings corresponding to "Create and manage Users with equal or less access" option	
Can Delete Users	Allowed
Roles	
Can View Roles	Not allowed
Can Create New Roles	Not allowed
Can Edit Role Properties (Warning: conferring this right will let Users with this Role edit their own rights)	Not allowed
Can Delete Roles	Not allowed
Delegate Authority	
Can only manipulate Users with equal or lesser rights	Allowed

The custom settings corresponding to the **Have full control over all Roles and Users** option are listed in the following table:

Custom settings corresponding to "Have full control over all Roles and Users" option	
Users	
Can View Users	Allowed
Can Create New Users	Allowed
Can Edit User Properties (User can always edit select properties of own account)	Allowed
Can Delete Users	Allowed
Roles	
Can View Roles	Allowed
Can Create New Roles	Allowed

Custom settings corresponding to "Have full control over all Roles and Users" option	
Can Edit Role Properties (Warning: conferring this right will let Users with this Role edit their own rights)	Allowed
Can Delete Roles	Allowed
Delegate Authority	
Can only manipulate Users with equal or lesser rights	Not applicable

Add users who can only receive reports

"Contacts" are users who cannot sign in to the Deep Security Manager but can periodically be sent reports (using scheduled tasks). Contacts can be assigned a "clearance" level that maps to existing roles. When a contact is sent a report, the report will not contain any information not accessible to a user of the same level. For example, three contacts may each be listed as the recipients of a weekly summary report but the contents of the three reports could be entirely different for each contact depending on their computer rights.

Add or edit a contact

1. In Deep Security Manager go to **Administration > User Management > Contacts**.
2. Click **New** to add a new contact or double-click an existing contact to edit its settings.
3. In the **General Information** section, specify the name, description, and preferred language of this contact.
4. In the **Contact Information** section, enter the email address to which reports will be sent if this contact is included in a report distribution list. (See the **Reports** page for more information.)
5. In the **Clearance** section, specify the role that determines the information this contact will be allowed to see. For example, if a computer report has been scheduled to be sent to this contact, only information on the computers that his role permits him access to will be included in the report.
6. In the **Password Protected Reports** section, select **Reports generated by this user are password protected** to password-protect exported PDF reports with the **Report Password**.

Delete a contact

To remove a contact from Deep Security Manager, click **Administration > User Management > Contacts**, click the contact, and then click **Delete**.

Create an API key for a user

To use the Deep Security Manager API, you will need an API key.

Note: API keys can only be used with the new "[Use the Deep Security API to automate tasks](#)" on page 1764 available in Deep Security Manager 11.1 and later.

Note: Trend Micro recommends creating one API key for every user needing API access to the Deep Security Manager.

Tip: You can automate API key creation using the Deep Security API. For examples, see the [Create and Manage API Keys](#) guide in the Deep Security Automation Center.

To create a new API key:

1. Go to **Administration > User Management > API Keys**.
2. Click **New**.
3. In the Properties window, enter a **Name** and **Description** for the API key.
4. Click on the **Role** list and select a role. **Auditor** grants read-only access to the Deep Security Manager through the API, while **Full Access** grants both read and write access. If you need more specific roles for API key users, you can select **New** and define one. See "[Define roles for users](#)" on page 1488 for more information on doing so.
5. Select a **Language**.
6. Select a **Time Zone**.
7. Optionally select **Expires on** and select an expiry date for the API key.
8. Click **OK**.
9. Copy the **Secret key value**.

Note: Make sure to copy the secret key value now, this is the only time it will be shown.

Lock out an existing API key

If an existing API key has been compromised you can lock it out:

1. Double click on the API key you want to lock out.
2. Optionally select **Locked Out (Denied permission to authenticate)** to block usage of the API key.
3. Click **OK**.

Unlock a locked out user name

If you have attempted to sign in multiple times to Deep Security Manager with an incorrect password, your user account will be locked out. The number of sign-in attempts allowed before lock out is configured in **Administration > System Settings > Security > Number of incorrect sign-in attempts allowed (before lock out)**.

You can unlock users in different ways, depending on the following situations:

- If an administrator user is available, see ["Unlock users as an administrator" below](#).
- If all the administrative users are locked out, see ["Unlock administrative users from a command line" below](#).

Unlock users as an administrator

1. Log in to Deep Security Manager with a working administrator user name and password.
2. Go to **Administration > User Management > Users**. Select the user you want to unlock, right-click, and click **Properties**.
3. In the wizard, go to **General > Sign-In Credentials**. Deselect the **Locked Out (Denied permission to sign in)** check box.
4. Click **Save**.

Unlock administrative users from a command line

1. Go to your local command line interface.

If your Deep Security Manager is Windows, go to the `..\Program Files\Trend Micro\Deep security Manager` directory.

If your Deep Security Manager is Linux, go to the `/opt/dsm` directory.

2. Enter the following command:

```
dsm_c -action unlockout -username <username>
```

Implement SAML single sign-on (SSO)

About SAML single sign-on (SSO)

Note: SAML single sign-on is not available when FIPS mode is enabled. See ["FIPS 140 support" on page 1811](#).

To implement SAML single sign-on, see ["Configure SAML single sign-on" on page 1509](#) or ["Configure SAML single sign-on with Microsoft Entra ID" on page 1515](#).

What are SAML and single sign-on?

Security Assertion Markup Language (or **SAML**) is an open authentication standard that allows for the secure exchange of user identity information from one party to another. SAML supports **single sign-on**, a technology that allows for a single user login to work across multiple applications and services. For Deep Security, implementing SAML single sign-on means that users signing in to your organization's portal would be able to seamlessly sign in to Deep Security without an existing Deep Security account.

How SAML single sign-on works in Deep Security

Establishing a trust relationship

In SAML single sign-on, a trust relationship is established between two parties: the **identity provider** and the **service provider**. The identity provider has the user identity information stored on a directory server. The service provider (which in this case is Deep Security) uses the identity provider's user identities for its own authentication and account creation.

The identity provider and the service provider establish trust by exchanging a **SAML metadata document** with one another.

Note: At this time, Deep Security supports **only** the HTTP POST binding of the SAML 2.0 identity provider (IdP)-initiated login flow, and not the service provider (SP)-initiated login flow

Creating Deep Security accounts from user identities

Once Deep Security and the identity provider have exchanged SAML metadata documents and established a trust relationship, Deep Security can access the user identities on the identity provider's directory server. However, before Deep Security can actually create accounts from the

user identities, account types need to be defined and instructions for transforming the data format need to be put in place. This is done using **groups**, **roles** and **claims**.

Groups and roles specify the tenant and access permissions that a Deep Security user account will have. Groups are created on the identity provider's directory server. The identity provider assigns user identities to one or more of the groups. Roles are created in the Deep Security Manager. There must be both a group and a role for each Deep Security account type, and their access permissions and tenant assignment must match.

Once there are matching groups and roles for each user type, the group data format needs to be transformed into a format Deep Security can understand. This is done by the identity provider with a claim. The claim contains instructions for transforming the group data format into the matching Deep Security role.

Tip: Learn more about the "[SAML claims structure](#)" on page 1512 required by Deep Security.

Below is a representation of this process:

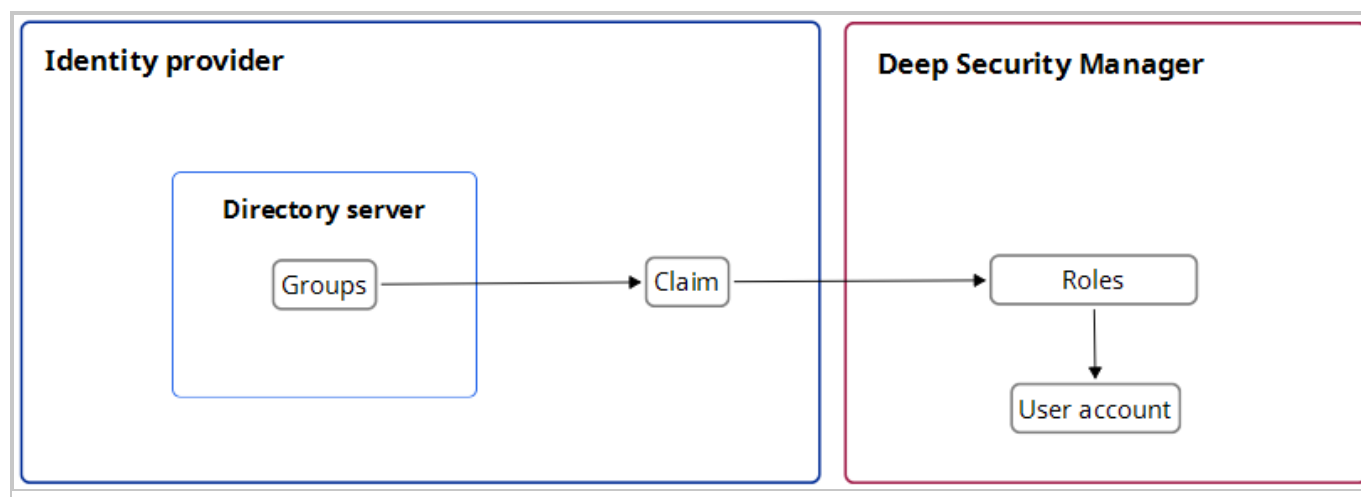

Implement SAML single sign-on in Deep Security

Once trust has been established between Deep Security and an identity provider with a SAML metadata document exchange, matching groups and roles have been created, and a claim put in place to translate the group data into roles, Deep Security can use SAML single sign-on to automatically make Deep Security accounts for users signing in through your organization's portal.

For more information on implementing SAML single sign-on, see "[Configure SAML single sign-on](#)" on the next page.

Configure SAML single sign-on

Note: SAML single sign-on is not available when FIPS mode is enabled. See ["FIPS 140 support" on page 1811](#).

When you configure Deep Security to use SAML single sign-on (SSO), users signing in to your organization's portal can seamlessly sign in to Deep Security without an existing Deep Security account. SAML single sign-on also makes it possible to implement user authentication access control features such as:

- Password strength or change enforcement.
- One-Time Password (OTP).
- Two-Factor Authentication (2FA) or Multi-Factor Authentication (MFA).

For a more detailed explanation of Deep Security's implementation of the SAML standard, see ["About SAML single sign-on \(SSO\)" on page 1507](#). If you are using Microsoft Entra ID as your identity provider, see ["Configure SAML single sign-on with Microsoft Entra ID" on page 1515](#).

Note: At this time, Deep Security supports **only** the HTTP POST binding of the SAML 2.0 identity provider (IdP)-initiated login flow, and not the service provider (SP)-initiated login flow

To use SAML single sign-on with Deep Security, you will need to do the following:

1. ["Configure pre-set up requirements" below](#)
2. ["Configure Deep Security as a SAML service provider" on the next page](#)
3. ["Configure SAML in Deep Security" on page 1511](#)
4. ["Provide information for your identity provider administrator" on page 1511](#)
5. ["SAML claims structure" on page 1512](#)
6. ["Test SAML single sign-on" on page 1515](#)
7. ["Service and identity provider settings" on page 1515](#)

Configure pre-set up requirements

1. Ensure your Deep Security Manager is functioning properly.
2. Contact the identity provider administrator to:
 - Establish a naming convention for mapping directory server groups to Deep Security roles.
 - Obtain their identity provider SAML metadata document.

- Ask them to add any required user authentication access control features to their policy.

Support is available to assist with the following identity providers that have been tested in Deep Security with SAML single sign-on:

- Active Directory Federation Services (ADFS)
- Okta
- PingOne
- Shibboleth
- [Microsoft Entra ID](#)

Configure Deep Security as a SAML service provider

First, set up Deep Security as a service provider.

Note: In multi-tenant Deep Security installations, only the primary tenant administrator can configure Deep Security as a SAML service provider.

1. In Deep Security Manager, go to **Administration > User Management > Identity Providers > SAML**.
2. Click **Get Started**.
3. Enter an **Entity ID** and a **Service Name**, and then click **Next**.

Note: The **Entity ID** is a unique identifier for the SAML service provider. The SAML specification recommends that the entity ID is a URL that contains the domain name of the entity, and industry practices use the SAML metadata URL as the entity ID. The SAML metadata is served from the /saml endpoint on the Deep Security Manager, so an example value might be `https://<DSMServerIP:4119>/saml`.

4. Select a certificate option, and click **Next**. The SAML service provider certificate is not used at this time, but would be used in the future to support service-provider-initiated login or single sign-out features. You can import a certificate by providing a PKCS #12 keystore file and password, or create a new self-signed certificate.
5. Follow the steps until you are shown a summary of your certificate details and then click **Finish**.

Configure SAML in Deep Security

Import your identity provider's SAML metadata document

Note: Your Deep Security account must have both administrator and "Create SAML identity provider" permissions.

1. On the Administration page, go to **User Management > Identity Providers > SAML**.
2. Click **Get Started**.
3. Click **Choose File**, select the SAML metadata document provided by your identity provider, and click **Next**.
4. Enter a **Name** for the identity provider, and then click **Finish**.

You will be brought to the Roles page.

Create Deep Security roles for SAML users

You need to create a role for each of your expected user types. Each role must have a corresponding group in your identity provider's directory server, and match the group's access permissions and tenant assignment.

Your identity provider's SAML integration will have a mechanism to transform group membership into SAML claims. Consult the documentation that came with your identity provider to learn more about claim rules.

For information on how to create roles, see ["Define roles for users" on page 1488](#).

Provide information for your identity provider administrator

Download the Deep Security Manager service provider SAML metadata document

1. On the Administration page, go to **User Management > Identity Providers > SAML**.
2. Under SAML Service Provider, click **Download**.
Your browser will download the Deep Security service provider SAML metadata document (`ServiceProviderMetadata.xml`).

Send URNs and the Deep Security SAML metadata document to the identity provider administrator

You need to give the identity provider administrator Deep Security's service provider SAML metadata document, the identity provider URN and the URN of each Deep Security role you created.

Tip:

To view role URNs, go to **Administration > User Management > Roles** and look under the URN column.

To view identity provider URNs, go to **Administration > User Management > Identity Providers > SAML > Identity Providers** and look under the URN column.

Once the identity provider administrator confirms they have created groups corresponding to the Deep Security roles and any required rules for transforming group membership into SAML claims, you are done with configuring SAML single sign-on.

Note: If necessary, you can inform the identity provider administrator about the ["SAML claims structure" below](#) required by Deep Security.

SAML claims structure

The following SAML claims are supported by Deep Security:

- ["Deep Security user name \(required\)" below](#)
- ["Deep Security user role \(required\)" on the next page](#)
- ["Maximum session duration \(optional\)" on the next page](#)
- ["Preferred language \(optional\)" on page 1514](#)

Deep Security user name (required)

The claim must have a SAML assertion that contains an `Attribute` element with a `Name` attribute of

`https://deepsecurity.trendmicro.com/SAML/Attributes/RoleSessionName` and a single `AttributeValue` element. The Deep Security Manager will use the `AttributeValue` as the Deep Security user name.

Sample SAML data (abbreviated)

```
<samlp:Response xmlns:samlp="urn:oasis:names:tc:SAML:2.0:protocol">
  <Assertion xmlns="urn:oasis:names:tc:SAML:2.0:assertion">
    <AttributeStatement>
      <Attribute
Name="https://deepsecurity.trendmicro.com/SAML/Attributes/RoleSessionName">
        <AttributeValue>alice</AttributeValue>
      </Attribute>
    </AttributeStatement>
  </Assertion>
</samlp:Response>
```



```

    </Attribute>
  </AttributeStatement>
</Assertion>
</samlp:Response>

```

Deep Security user role (required)

The claim must have a SAML assertion that contains an `Attribute` element with a `Name` attribute of `https://deepsecurity.trendmicro.com/SAML/Attributes/Role` and between one and ten `AttributeValue` elements. The Deep Security Manager uses the attribute value(s) to determine the tenant, identity provider, and role of the user. A single assertion may contain roles from multiple tenants.

Note: The `AttributeValue` contains two URNs, separated by a comma. The URNs are case sensitive.

Sample SAML data (abbreviated)

Note: The line break in the `AttributeValue` element is present for readability; in the claim it must be on a single line.

```

<samlp:Response xmlns:samlp="urn:oasis:names:tc:SAML:2.0:protocol">
  <Assertion xmlns="urn:oasis:names:tc:SAML:2.0:assertion">
    <AttributeStatement>
      <Attribute
Name="https://deepsecurity.trendmicro.com/SAML/Attributes/Role">
        <AttributeValue>urn:tmds:identity:[pod ID]:[tenant ID]:saml-
provider/[IDP name],
          urn:tmds:identity:[pod ID]:[tenant ID]:role/[role
name]</AttributeValue>
      </Attribute>
    </AttributeStatement>
  </Assertion>
</samlp:Response>

```

Maximum session duration (optional)

If the claim has a SAML assertion that contains an `Attribute` element with a `Name` attribute of `https://deepsecurity.trendmicro.com/SAML/Attributes/SessionDuration` and an

integer-valued `AttributeValue` element, the session will automatically terminate when that amount of time (in seconds) has elapsed.

Sample SAML data (abbreviated)

```
<samlp:Response xmlns:samlp="urn:oasis:names:tc:SAML:2.0:protocol">
  <Assertion xmlns="urn:oasis:names:tc:SAML:2.0:assertion">
    <AttributeStatement>
      <Attribute
Name="https://deepsecurity.trendmicro.com/SAML/Attributes/SessionDuration">
        <AttributeValue>28800</AttributeValue>
      </Attribute>
    </AttributeStatement>
  </Assertion>
</samlp:Response>
```

Preferred language (optional)

If the claim has a SAML assertion that contains an `Attribute` element with the `Name` attribute of `https://deepsecurity.trendmicro.com/SAML/attributes/PreferredLanguage` and a string-valued `AttributeValue` element that is equal to one of the supported languages, the Deep Security Manager will use the value to set the user's preferred language.

The following languages are supported:

- `en-US` (US English)
- `ja-JP` (Japanese)

Sample SAML data (abbreviated)

```
<samlp:Response xmlns:samlp="urn:oasis:names:tc:SAML:2.0:protocol">
  <Assertion xmlns="urn:oasis:names:tc:SAML:2.0:assertion">
    <AttributeStatement>
      <Attribute
Name="https://deepsecurity.trendmicro.com/SAML/Attributes/PreferredLanguage">
        <AttributeValue>en-US</AttributeValue>
      </Attribute>
    </AttributeStatement>
```

```
</Assertion>  
</samlp:Response>
```

Test SAML single sign-on

Navigate to the single sign-on login page on the identity provider server, and log in to the Deep Security Manager from there. You should be redirected to the Deep Security Manager console. If SAML single sign-on is not functioning, follow the steps below:

Review the set-up

1. Review the "[Configure pre-set up requirements](#)" on page 1509 section.
2. Ensure that the user is in the correct directory group.
3. Ensure that the identity provider and role URNs are properly configured in the identity provider federation service.

Create a Diagnostic Package

1. Go to **Administration > System Information** and click **Diagnostic Logging**.
2. Select **SAML integration Issues** and click **Save**.
3. Generate logs. Replicate the issue by logging in to the Deep Security Manager through your identity provider.
4. After the login fails, generate a diagnostic package by navigating to **Administration > System Information** and clicking on **Create Diagnostic Package**.
5. Once the diagnostic package has been created, navigate to <https://success.trendmicro.com> to open a Technical Support Case, and upload the diagnostic package during the case creation.

Service and identity provider settings

You can set how far in advance Deep Security will alert you to the expiry date of the server and identity provider certificates, as well as how much time must pass before inactive user accounts added through SAML single sign-on are automatically deleted.

To change these settings, go to **Administration > System Settings > Security > Identity Providers**.

Configure SAML single sign-on with Microsoft Entra ID

For a detailed explanation of Deep Security's implementation of the SAML standard, see "[About SAML single sign-on \(SSO\)](#)" on page 1507. For instructions on configuring it with other identity providers, see "[Configure SAML single sign-on](#)" on page 1509.

Note:

- SAML single sign-on is not available when FIPS mode is enabled. See ["FIPS 140 support" on page 1811](#).
- At this time, Deep Security supports **only** the HTTP POST binding of the SAML 2.0 identity provider (IdP)-initiated login flow, and not the service provider (SP)-initiated login flow.

Who is involved in this process?

Typically, there are two people required to configure Deep Security Manager to use Microsoft Entra ID for SAML single sign-on (SSO): a Deep Security administrator and a Microsoft Entra ID administrator.

The Deep Security administrator must be assigned a Deep Security role with the **SAML Identity Providers** right set to either **Full** or to **Custom** with **Can Create New SAML Identity Providers** enabled.

These are the steps required to set up SAML single sign-on with Deep Security using Microsoft Entra ID, and the person who performs each step:

Step	Performed by
"Configure Deep Security as a SAML service provider" below	Deep Security administrator
"Download the Deep Security service provider SAML metadata document" on the next page	Deep Security administrator
"Configure Microsoft Entra ID" on the next page	Microsoft Entra ID administrator
"Configure SAML in Deep Security" on page 1518	Deep Security administrator
"Define a role in Microsoft Entra ID" on page 1519	Microsoft Entra ID administrator

Configure Deep Security as a SAML service provider

First, set up Deep Security as a service provider.

Note: In multi-tenant Deep Security installations, only the primary tenant administrator can configure Deep Security as a SAML service provider.

1. In Deep Security Manager, go to **Administration > User Management > Identity Providers > SAML**.
2. Click **Get Started**.
3. Enter an **Entity ID** and a **Service Name**, and then click **Next**.

Note: The **Entity ID** is a unique identifier for the SAML service provider. The SAML specification recommends that the entity ID is a URL that contains the domain name of the entity, and industry practices use the SAML metadata URL as the entity ID. The SAML metadata is served from the /saml endpoint on the Deep Security Manager, so an example value might be `https://<DSMServerIP:4119>/saml`.

4. Select a certificate option, and click **Next**. The SAML service provider certificate is not used at this time, but would be used in the future to support service-provider-initiated login or single sign-out features. You can import a certificate by providing a PKCS #12 keystore file and password, or create a new self-signed certificate.
5. Follow the steps until you are shown a summary of your certificate details and then click **Finish**.

Download the Deep Security service provider SAML metadata document

In Deep Security Manager, go to **Administration > User Management > Identity Providers > SAML** and click **Download**. The file is downloaded as `ServiceProviderMetadata.xml`. Send the file to your Microsoft Entra ID administrator.

Configure Microsoft Entra ID

The steps in this section are performed by a Microsoft Entra ID administrator.

Refer to [Configure single sign-on to non-gallery applications in Microsoft Entra ID](#) for details on how to perform the steps below.

1. In the Microsoft Entra ID portal, add a new non-gallery application.
2. Configure single sign-on for the application. We recommend that you upload the metadata file, `ServiceProviderMetadata.xml`, that was downloaded from Deep Security Manager. Alternatively, you can enter a reply URL (the Deep Security Manager URL + `/saml`).

3. Configure SAML claims. Deep Security requires these two:

- `https://deepsecurity.trendmicro.com/SAML/Attributes/RoleSessionName`
This is a unique user ID that will be the username in Deep Security. For example, you could use the User Principal Name (UPN).
- `https://deepsecurity.trendmicro.com/SAML/Attributes/Role`
The format is "IDP URN,Role URN". The IDP has not been created in Deep Security Manager yet, so you can configure this SAML claim later, in ["Define a role in Microsoft Entra ID" on the next page](#).

You can also configure other optional claims, as described in ["SAML claims structure" on the next page](#).

4. Download the **Federation Metadata XML** file and send it to the Deep Security administrator.

If there are multiple roles defined in Deep Security, repeat these steps to create a separate application for each role.

Configure SAML in Deep Security

Import the Microsoft Entra ID metadata document

1. In Deep Security Manager, go to **Administration > User Management > Identity Providers > SAML**.
2. Click **Get Started** or **New**.
3. Click **Choose File**, select the Federation Metadata XML file that was downloaded from Microsoft Entra ID and click **Next**.
4. Enter a **Name** for the identity provider, and then click **Finish**.

You will be brought to the **Roles** page.

Create Deep Security roles for SAML users

Make sure the **Administration > User Management > Roles** page in Deep Security contains appropriate roles for your organization. Users should be assigned a role that limits their activities to only those necessary for the completion of their duties. For information on how to create roles, see ["Define roles for users" on page 1488](#). Each Deep Security role requires a corresponding Microsoft Entra ID application.

Get URNs

In Deep Security Manager, gather this information, which you will need to provide to your Microsoft Entra ID administrator:

- The identity provider URN. To view identity provider URNs, go to **Administration > User Management > Identity Providers > SAML > Identity Providers** and check the URN column.
- The URN of the Deep Security role to associate with the Microsoft Entra ID application. To view role URNs, go to **Administration > User Management > Roles** and check the URN column. If you have multiple roles, you will need the URN for each role, because each one requires a separate Microsoft Entra ID enterprise application.

Define a role in Microsoft Entra ID

The steps in this section must be performed by a Microsoft Entra ID administrator.

In Microsoft Entra ID, use the identity provider URN and role URN identified in the previous section to define the "role" attribute in the enterprise application. This must be in the format "IDP URN,Role URN". See "Deep Security user role (required)" in the ["SAML claims structure" below](#) section.

Use the Validate button in Microsoft Entra ID to test the setup, or assign the new application to a user and test that it works.

Service and identity provider settings

You can set how far in advance Deep Security will alert you to the expiry date of the server and identity provider certificates, as well as how much time must pass before inactive user accounts added through SAML single sign-on are automatically deleted.

To change these settings, go to **Administration > System Settings > Security > Identity Providers**.

SAML claims structure

The following SAML claims are supported by Deep Security:

- ["Deep Security user name \(required\)" on the next page](#)
- ["Deep Security user role \(required\)" on the next page](#)

- "Maximum session duration (optional)" on the next page
- "Preferred language (optional)" on page 1522

Deep Security user name (required)

The claim must have a SAML assertion that contains an `Attribute` element with a `Name` attribute of

`https://deepsecurity.trendmicro.com/SAML/Attributes/RoleSessionName` and a single `AttributeValue` element. The Deep Security Manager will use the `AttributeValue` as the Deep Security user name.

Sample SAML data (abbreviated)

```
<samlp:Response xmlns:samlp="urn:oasis:names:tc:SAML:2.0:protocol">
  <Assertion xmlns="urn:oasis:names:tc:SAML:2.0:assertion">
    <AttributeStatement>
      <Attribute
Name="https://deepsecurity.trendmicro.com/SAML/Attributes/RoleSessionName">
        <AttributeValue>alice</AttributeValue>
      </Attribute>
    </AttributeStatement>
  </Assertion>
</samlp:Response>
```

Deep Security user role (required)

The claim must have a SAML assertion that contains an `Attribute` element with a `Name` attribute of `https://deepsecurity.trendmicro.com/SAML/Attributes/Role` and between one and ten `AttributeValue` elements. The Deep Security Manager uses the attribute value(s) to determine the tenant, identity provider, and role of the user. A single assertion may contain roles from multiple tenants.

Note: The `AttributeValue` contains **two** URNs, separated by a comma. The URNs are case sensitive.

Sample SAML data (abbreviated)

Note: The line break in the `AttributeValue` element is present for readability; in the claim it must be on a single line.

```
<samlp:Response xmlns:samlp="urn:oasis:names:tc:SAML:2.0:protocol">
  <Assertion xmlns="urn:oasis:names:tc:SAML:2.0:assertion">
    <AttributeStatement>
      <Attribute
Name="https://deepsecurity.trendmicro.com/SAML/Attributes/Role">
        <AttributeValue>urn:tmds:identity:[pod ID]:[tenant ID]:saml-
provider/[IDP name],
          urn:tmds:identity:[pod ID]:[tenant ID]:role/[role
name]</AttributeValue>
        </Attribute>
      </AttributeStatement>
    </Assertion>
  </samlp:Response>
```

Maximum session duration (optional)

If the claim has a SAML assertion that contains an `Attribute` element with a `Name` attribute of `https://deepsecurity.trendmicro.com/SAML/Attributes/SessionDuration` and an integer-valued `AttributeValue` element, the session will automatically terminate when that amount of time (in seconds) has elapsed.

Sample SAML data (abbreviated)

```
<samlp:Response xmlns:samlp="urn:oasis:names:tc:SAML:2.0:protocol">
  <Assertion xmlns="urn:oasis:names:tc:SAML:2.0:assertion">
    <AttributeStatement>
      <Attribute
Name="https://deepsecurity.trendmicro.com/SAML/Attributes/SessionDuratio
n">
        <AttributeValue>28800</AttributeValue>
      </Attribute>
    </AttributeStatement>
  </Assertion>
</samlp:Response>
```

Preferred language (optional)

If the claim has a SAML assertion that contains an `Attribute` element with the `Name` attribute of `https://deepsecurity.trendmicro.com/SAML/attributes/PreferredLanguage` and a string-valued `AttributeValue` element that is equal to one of the supported languages, the Deep Security Manager will use the value to set the user's preferred language.

The following languages are supported:

- `en-US` (US English)
- `ja-JP` (Japanese)

Sample SAML data (abbreviated)

```
<samlp:Response xmlns:samlp="urn:oasis:names:tc:SAML:2.0:protocol">
  <Assertion xmlns="urn:oasis:names:tc:SAML:2.0:assertion">
    <AttributeStatement>
      <Attribute
Name="https://deepsecurity.trendmicro.com/SAML/Attributes/PreferredLanguage"
      >
        <AttributeValue>en-US</AttributeValue>
      </Attribute>
    </AttributeStatement>
  </Assertion>
</samlp:Response>
```

Manage the database

General database maintenance

To improve Deep Security Manager performance, we recommend that you perform regular index maintenance on the Deep Security database to keep it from becoming overly fragmented. Follow your organization's best practices for reindexing databases, or refer to your database vendor's documentation for guidance:

- **PostgreSQL:** See <https://www.postgresql.org/docs/10/sql-reindex.html> for details on the PostgreSQL reindex command.

- **Microsoft SQL:** Refer to documentation from Microsoft for index maintenance best practices: <https://docs.microsoft.com/en-us/sql/relational-databases/indexes/reorganize-and-rebuild-indexes?view=sql-server-ver15>. See also [Options in the Back Up Database Task for Maintenance Plan](#).
- **Oracle Database:** Follow Oracle's best practices on managing indexes. For example, see https://docs.oracle.com/cd/B28359_01/server.111/b28310/indexes002.htm#ADMIN11713.

There are also open source websites that provide scripts that can help you with this task.

Tip: Reindexing may block some operations, so it's best to run it offline.

Maintain PostgreSQL

Follow these database maintenance and tuning recommendations:

1. Configure database log rotation and performance settings.

For best practices, see ["Log rotation" on the next page](#), ["Lock management" on page 1525](#), ["Maximum concurrent connections" on page 1525](#), ["Autovacuum settings" on page 1526](#), etc.

Steps vary by distribution and managed hosting:

- **Self-hosted database:** Defaults are generic values from the PostgreSQL core distribution. **Some defaults are not appropriate** for data center or customized cloud installs, especially in larger deployments.

To change settings:

- In a plain text editor, open the [postgresql.conf file](#).
 - Edit the parameters.
 - Save the file.
 - Restart the PostgreSQL service.
- **Amazon RDS:** Defaults vary by instance size. Often, you only need to fine tune [autovacuuming](#), [max_connections](#) and [effective_cache_size](#). To change settings, use [database parameter groups](#) and then restart the database instance.

- **Amazon Aurora:** Defaults vary by instance size. Often, you only need to fine tune autovacuuming, `max_connections` and `effective_cache_size`. To change settings, use [database parameter groups](#) and then restart the database instance.

Tip: When fine tuning performance, verify settings by monitoring your database IOPS with a service such as Amazon CloudWatch.

Tip: If you need additional help, PostgreSQL offers [professional support](#).

Log rotation

In PostgreSQL core distributions, by default, the database's local log file has no age or file size limit. Logs will gradually consume more disk space.

To prevent that, configure parameters for either [remote logging to a Syslog log destination](#), or local log rotation.

Log files can be rotated based on age limit, file size limit, or both (whichever occurs sooner). When a limit is reached, depending on whether a log file exists that matches the file name pattern at that time, PostgreSQL either creates a new file or reuses an existing one. Reuse can either append or (for age limit) overwrite.

Log rotation parameters are:

- `logging_collector`: Enter "on" to enable database logging.
- `log_filename`: Log file name pattern. Patterns mostly use [IEEE standard time and date formatting](#).
- `log_truncate_on_rotation`: Enter either "off" to append to the existing log file, or "on" to overwrite it. Only applies when time-based log rotation occurs. (File size-based log rotation always appends.)
- `log_rotation_age`: Maximum age in minutes of a log file. Enter "0" to disable time-based log rotation.
- `log_rotation_size`: Maximum size in kilobytes (KB) of a log file. Enter "0" to disable file size-based log rotation.

Example: Daily Database Log Rotation

These parameters create 7 rotating database log files: one for each day of the week . (File names are "postgresql-Mon.log" for Monday, etc.)

Each day (1440 minutes) either creates a file with that day's name (if none exists) or overwrites that day's log file from the previous weekly cycle.

During heavy load, logging can *temporarily exceed disk space quota* because the file size limit is disabled. However the number and names of files does not change.

```
log_collector = on
log_filename = 'postgresql-%a.log'
log_rotation_age = 1440
log_rotation_size = 0
log_truncate_on_rotation = on
```

Lock management

Increase `deadlock_timeout` to exceed your deployment's normal transaction time.

Each time a query waits for a lock for more than `deadlock_timeout`, PostgreSQL checks for a deadlock condition and (if configured) logs an error. On larger deployments during heavy load, however, it's often normal (not an error) to wait for more than 1 second. Logging these normal events decreases performance.

Maximum concurrent connections

Increase to `max_connections = 500`.

Effective cache size

Consider increasing `effective_cache_size`. This setting is used to estimate cache effects by a query. It only affects cost estimates during query planning, and doesn't cause more RAM usage.

Shared buffers

Increase `shared_buffers` to 25% of the RAM. This setting specifies how much memory PostgreSQL can use to cache data, which improves performance.

Work memory and maintenance work memory

Increase `work_mem`. This setting specifies the amount of RAM that can be used by internal sort operations and hash tables before writing to temporary disk files. More memory is required when running complex queries.

Consider increasing `maintenance_work_mem`. This setting determines the maximum amount of memory used for maintenance operations such as `ALTER TABLE`.

Checkpoints

Reduce checkpoint frequency. Checkpoints usually cause most writes to data files. To optimize performance, most checkpoints should be "timed" (triggered by `checkpoint_timeout`), not "requested" (triggered by filling all the available WAL segments or by an explicit `CHECKPOINT` command).

Parameter name	Recommended value
<code>checkpoint_timeout</code>	15min
<code>checkpoint_completion_target</code>	0.9
<code>max_wal_size</code>	16GB

Write-ahead log (WAL)

If you use database replication, consider using `wal_level = replica`.

Autovacuum settings

PostgreSQL requires periodic maintenance called "vacuuming". Usually, you don't need to change the default value for `autovacuum_max_workers`.

On the `entitys` and `attribute2s` tables, if frequent writes cause many rows to change often (such as in large deployments with short-lived cloud instances), then autovacuum should run more frequently to minimize disk space usage and maintain performance. Parameters must be set on both the overall database and those specific tables.

Database-level parameter name	Recommended value
<code>autovacuum_work_mem</code>	1GB

Table-level parameter name	Recommended value
<code>autovacuum_vacuum_cost_delay</code>	10
<code>autovacuum_vacuum_scale_factor</code>	0.01
<code>autovacuum_analyze_scale_factor</code>	0.005

To change the database-level setting, you must edit the configuration file or database parameter group, and then reboot the database server. Commands cannot change that setting while the database is running.

To change the table-level settings, you can either edit the configuration file or database parameter group, or enter these commands:

```
ALTER TABLE public.entitys SET (autovacuum_enabled = true, autovacuum_vacuum_cost_delay = 10, autovacuum_vacuum_scale_factor = 0.01, autovacuum_analyze_scale_factor = 0.005);
```

```
ALTER TABLE public.attribute2s SET (autovacuum_enabled = true, autovacuum_vacuum_cost_delay = 10, autovacuum_vacuum_scale_factor = 0.01, autovacuum_analyze_scale_factor = 0.005);
```

PostgreSQL on Linux

Transparent huge pages

Transparent huge pages (THP) is a Linux memory management system that reduces the overhead of translation lookaside buffer (TLB) lookups on computers with large amounts of RAM by using larger memory pages. By default, THP is enabled, but it isn't recommended for PostgreSQL database servers. To disable it, see your OS vendor's documentation.

Host-based authentication

Host-based authentication (HBA) can prevent unauthorized access to the database from other computers that aren't in the allowed IP address range. By default, Linux doesn't have HBA

restrictions for databases. However it's usually better to use a security group or firewall instead.

Maintain Microsoft SQL Server Express

Follow these database maintenance recommendations:

- Remove any unneeded agent software packages from the Deep Security Manager to save disk space in the database.
- Security updates and events require additional space in the database. Monitor your deployment to ensure that you stay within the [Express database size limit](#). For information on database pruning, see "[Log and event storage best practices](#)" on page 1129. You may also choose to use the SQL Server settings described in [Considerations for the "autogrow" and "autoshrink" settings in SQL Server](#).

Migrate Microsoft SQL Server Express to Enterprise

Microsoft SQL Server Express is supported in very limited deployments (see "[Microsoft SQL Server Express considerations](#)" on page 436 for details). If you are using a Microsoft SQL Server Express database but find its limitations too constricting, you can migrate it to Microsoft SQL Server Enterprise edition, or another [supported database](#).

To migrate to Enterprise:

1. Stop the Deep Security Manager service so that it stops writing to the database.

Deep Security Agents will continue to apply their current protection policies while the manager is stopped. Events will be kept and transmitted when Deep Security Manager returns online.

2. Back up the database(s).
3. Back up the database connection settings file:

```
[Deep Security install directory]/webclient/webapps/ROOT/WEB-INF/dsm.properties
```

4. Move the database to the new database engine. Restore the backup.
5. Edit `dsm.properties` to connect to the migrated database:

```
database.SqlServer.user
```



```
database.name
```

```
database.SqlServer.instance
```

```
database.SqlServer.password
```

```
database.type
```

```
database.SqlServer.server
```

If using the default instance, you can delete the `database.SqlServer.instance` setting.

You can enter a plain text password for `database.SqlServer.password`; Deep Security Manager will encrypt it when the service starts, like this:

```
database.SqlServer.password=!CRYPT!20DE3D96312D6803A53C0D1C691FE6DEB7  
476104C0A
```

6. Restart the Deep Security Manager service.
7. To verify that it has successfully reconnected to the database, log in to Deep Security Manager.

Existing protected computers and event logs should appear. As new events such as administrator logins or policy changes occur, they should be added. If not, verify that you have granted permissions to the database user account on the new database server.

Back up and restore your database

Separate from high availability or load balancing, best practices include regular database backups and a disaster recovery plan. Backups can be used to restore the database if there is a serious failure.

Back up your database

Consult your database vendor's documentation for instructions on how to back up your database.

Tip: For RDS, follow the instructions provided by AWS for backing up your database to an S3 bucket. For example, see [Amazon RDS for SQL Server - Support for Native Backup/Restore to Amazon S3](#).

Tip: For PostgreSQL databases, basic tools like `pg_dump` or `pg_basebackup` are not suitable to back up and restore in an enterprise environment. Consider other tools such as [Barman](#).

Restore the database only

1. Stop the Deep Security Manager service.
2. Restore the database.
This must be a database from the same version number of the Deep Security Manager.
3. Start the Deep Security Manager service.
4. Verify contents restored.
5. Update all of the computers to ensure they have the proper configuration.

Restore both the Deep Security Manager and the database

1. Remove any remnants of the lost or corrupted Deep Security Manager. When uninstalling Deep Security Manager, don't choose to keep configuration files.
2. Restore the database.
3. Find the version of the Deep Security Manager installer that supports your database and install it. During the installation, in the Database options, select the **Add a new Manager node** option.
4. After installing Deep Security Manager successfully, open the Deep Security Manager console, go to **Administration > Manager Nodes**, and decommission the old offline Manager node.

Export objects in XML or CSV format

- **Events:** Go to one of the Events pages and use the Advanced Search options to filter the event data. For example, you could search for all firewall events for computers in the Computers > Laptops computer group that were logged within the last hour whose reason column contains the word spoofed.

The screenshot shows the 'Firewall Events' search interface. At the top, there are two dropdown menus: 'All' and 'No Grouping'. To the right is a search bar with a magnifying glass icon and the text 'Search'. Below this, there are three rows of filters:

- Period: Last Hour
- Computers: In Group (dropdown) and Computers > Laptops (dropdown)
- Search: Reason (dropdown), Contains (dropdown), and spoofed (text input)

 On the right side of the filter area, there is a blue vertical bar containing a white right-facing arrow icon, which is the submit button.

Click the submit button (with the right-facing arrow) to execute the "query". Then click **Export** to export the filtered data in CSV format. You can export all the displayed entries or just selected data. The exporting of logs in this format is primarily for integration with third-party reporting tools.

- **Computer Lists:** Computers lists can be exported in XML or CSV format from the **Computers** page. You might want to do this if you find you are managing too many computers from a single Deep Security Manager and are planning to set up a second Deep Security Manager to manage a collection of computers. Exporting a list of selected computers will save you the trouble of rediscovering all of the computers again and arranging them into groups.

Note: Policy, firewall rule, and intrusion prevention rule settings will *not* be included. You will have to export your firewall rules, intrusion prevention rules, firewall stateful configurations, and policies as well and then reapply them to your computers.

- **Policies:** To export these in XML format, go to **Policies**.

Note: When you export a selected policy to XML, any child policies the policy might have are included in the exported package. The export package contains all of the actual objects associated with the policy except: intrusion prevention rules, log inspection rules, integrity monitoring rules, and application types.

- **Firewall Rules:** Firewall rules can be exported to an XML or CSV file using the same searching and filtering techniques as above.
- **Firewall Stateful Configurations:** Firewall stateful configurations can be exported to an XML or CSV file using the same searching and filtering techniques as above.
- **Intrusion Prevention Rules:** Intrusion prevention rules can be exported to an XML or CSV file using the same searching and filtering techniques as above.
- **Integrity Monitoring Rules:** Integrity monitoring rules can be exported to an XML or CSV file using the same searching and filtering techniques as above.
- **Log Inspection Rules:** Log inspection rules can be exported to an XML or CSV file using the same searching and filtering techniques as above.
- **Other Common Objects :** All the reusable components common objects can be exported to an XML or CSV file the same way.

When exporting to CSV, only displayed column data is included. Use the Columns tool to change which data is displayed. Grouping is ignored so the data might not be in same order as on the screen.

Import objects

To import each of the individual objects into Deep Security, next to **New** in the object page's toolbar, select **Import From File** .

Navigate and customize Deep Security Manager

Customize the dashboard

The dashboard is the first page that appears after you log in to Deep Security Manager.

Each user can customize the contents and layout of their dashboard. Deep Security Manager automatically saves your settings, and will remember your dashboard the next time that you log in. You can also configure the data's time period, and which computer's or computer group's data is displayed.

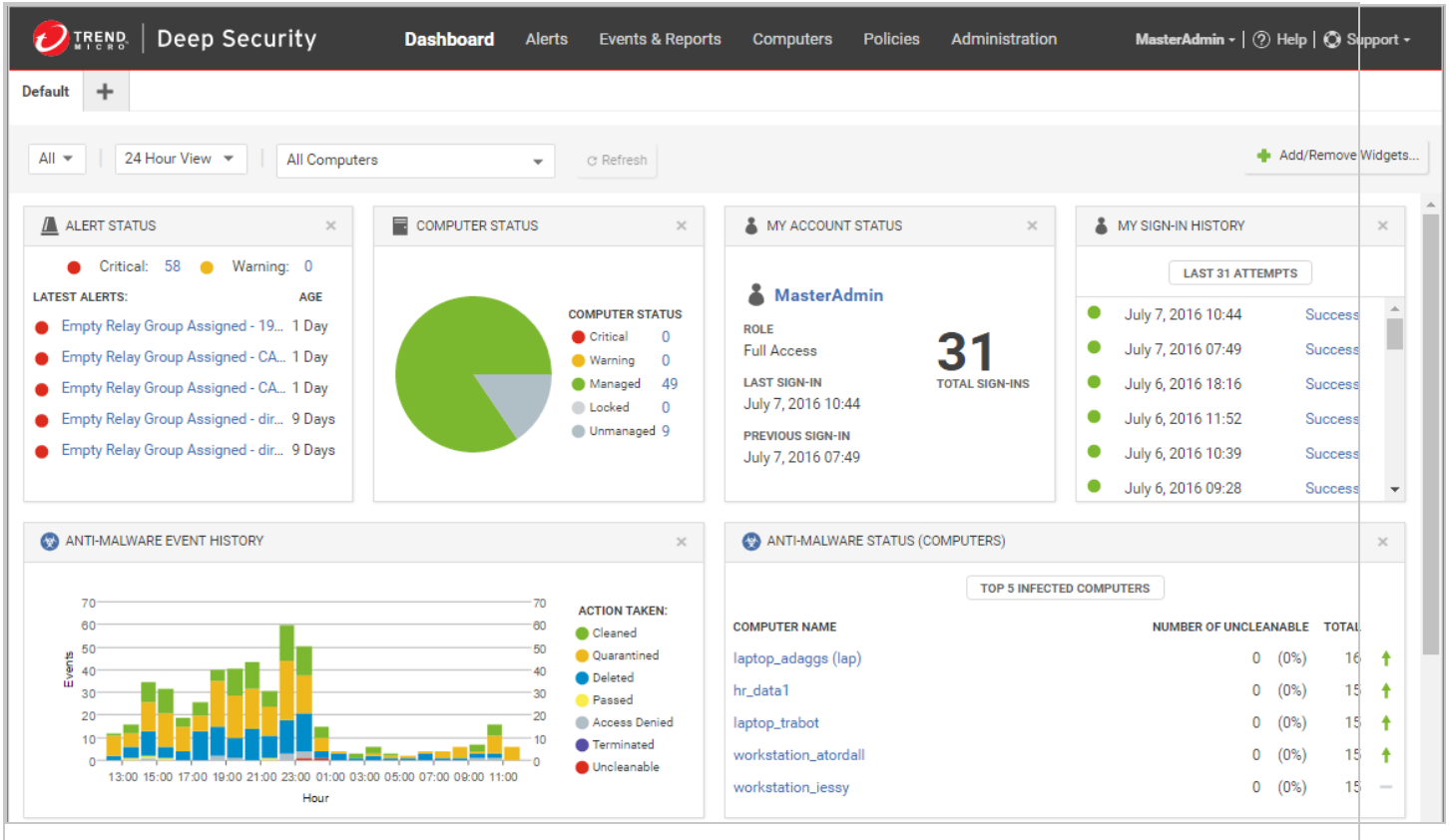

Specify date and time range

The dashboard can display data from either the last 24 hours or the last seven days, as per the following illustration:

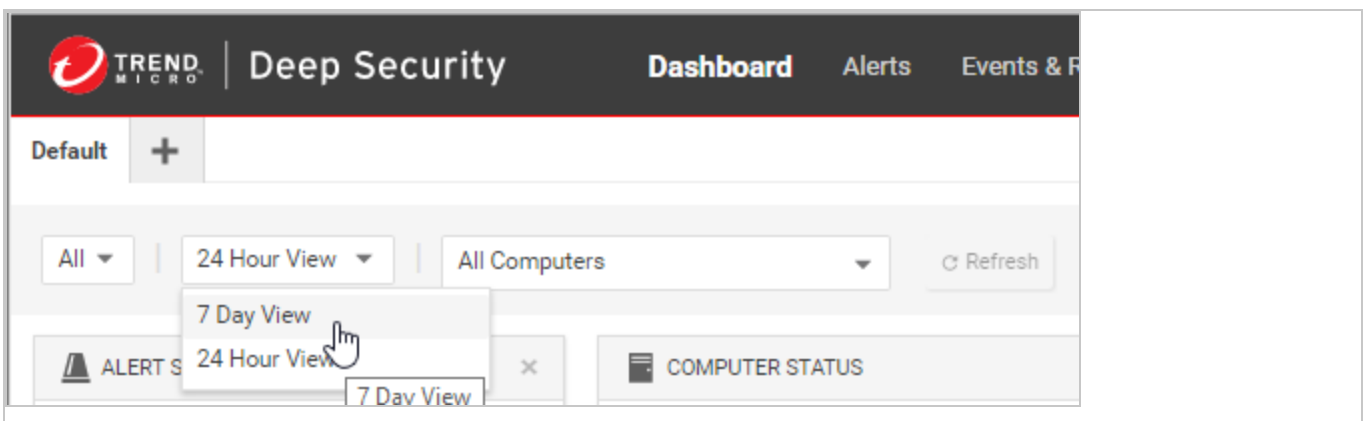

Specify computers and computer groups

You can use the **Computer** option to filter the displayed data to only data from specific computers. For example, only computers using the **Linux Server** security policy, as per the following illustration:

The screenshot displays the Trend Micro Deep Security dashboard. The top navigation bar includes 'Dashboard', 'Actions', 'Alerts', 'Events & Reports', 'Computers', 'Policies', and 'Administration'. Below the navigation bar, there are several filters: 'All', '24 Hour View', 'Using Policy:', and 'None'. A dropdown menu is open for the 'Using Policy:' filter, showing a list of policies: 'None', 'Base Policy', 'Deep Security', 'Linux Server', 'Solaris Server', and 'Windows'. A mouse cursor is pointing at the 'Linux Server' option. The dashboard also features an 'Alert Status' panel on the left with a list of alerts, a 'Computer Status' panel with a pie chart, and a 'PREVIOUS SIGN-IN' panel on the right.

Filter by tags

In Deep Security, a tag is a unit of metadata that you can apply to an event in order to create an additional attribute for the event that is not originally contained within the event itself. Tags can be used to filter events to simplify the task of event monitoring and management. A typical use of tagging is to distinguish between events that require action and those that have been investigated and found to be benign.

Data displayed in the **Dashboard** can be filtered by tags, as per the following illustration:

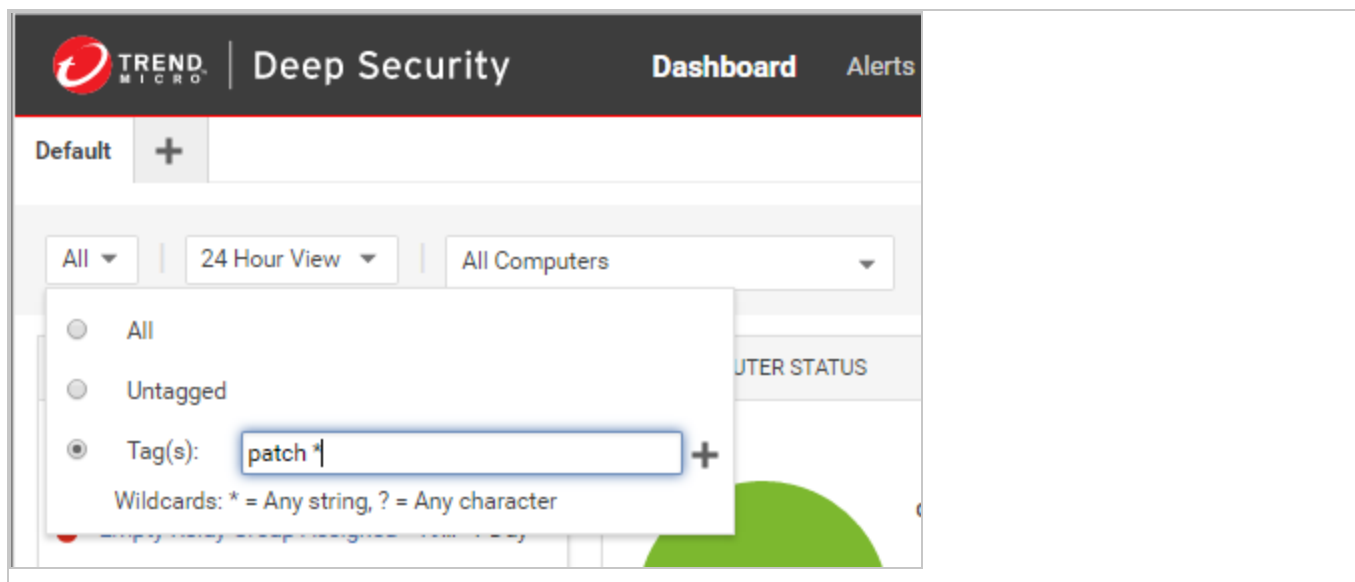

For more information, see ["Apply tags to identify and group events"](#) on page 1136.

Select dashboard widgets

Click **Add/Remove Widgets** to display the widget selection window and choose which widgets to display, as per the following illustration:

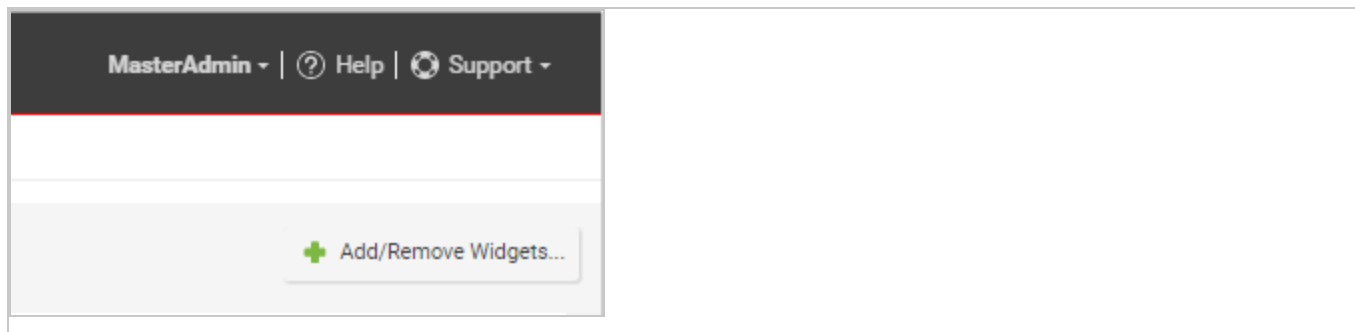

If widgets take up extra space on the dashboard (more than 1x1), their dimensions are listed next to their names.

The following widgets are available:

Monitoring:

- **Activity Overview:** Overview of activity, including the number of protected hours and size of database.
- **Alert History [2x1]:** Recent alert history, including the severity of alerts.

- **Alert Status:** Summary of alerts, including their age and severity.
- **Computer Status:** Summary of computers, including whether they are managed or unmanaged, and if there are any warnings or critical alerts.
- **Manager Node Status [3x1]:** The name, CPU usage, memory, jobs, and system events on the manager node.
- **Security Update Status:** The update status of computers, including the number of computers that are up-to-date, out-of-date, and unknown.
- **Tenant Database Usage:** The top five tenants ranked by their database size.
- **Tenant Job Activity:** The top five tenants ranked by their total number of jobs.
- **Tenant Protection Activity:** The top five tenants ranked by the hours they've been protected.
- **Tenant Security Event Activity:** The top five tenants ranked by their total number of security events.
- **Tenant Sign-In Activity:** The top five tenants ranked by their sign-in activity.
- **Tenant System Event Activity:** The top five tenants ranked by their total number of system events.
- **Tenants:** Tenant information, including the number of tenants and the amount of hours they have been protected.

Note that the out-of-date category does not include computers with the status Anti-malware Configuration Off, Anti-malware Engineer Offline, and Agent Offline. These statuses have been separated from the general out-of-date classification and categorized individually as **Out of Date (Anti-Malware Configuration Off)**, **Out of Date (Anti-Malware Offline)**, and **Out of Date (Agent Offline)**. Computers with these statuses are not counted in the total displayed on the **Security Update Status** widget under **Out-of-Date**.

System:

- **My Sign-in History:** The last 50 sign-in attempts and whether or not they were successful.
- **My User Summary [2x1]:** A summary of the user, including name, role, and sign-in information.
- **Software Updates:** Out-of-date computers.
- **System Event History [2x1]:** Recent system event history, including the number of events that are categorized as info, warning, or error.

Ransomware:

- **Ransomware Event History [3x1]:** Recent ransomware event history, including the event type.
- **Ransomware Status:** The status of ransomware, including the number of ransomware events that occurred in the last 24 hours, the last 7 days, or the last 13 weeks.

Anti-Malware:

- **Anti-Malware Event History [2x1]:** Recent anti-malware event history, including the action taken for the events.
- **Anti-Malware Protection Status:** A summary of Anti-Malware Protection status on computers, including whether they are protected, unprotected, or not capable of being protected.
- **Anti-Malware Status (Computers) [2x1]:** The top five infected computers, including the amount of uncleanable files and the total number of files affected.
- **Anti-Malware Status (Malware) [2x1]:** The top five detected malware, including their name, amount of uncleanable files, and number of times it was triggered.
- **Malware scan Status [2x1]:** The top five appliances with incomplete scheduled malware scans.

Web Reputation:

- **Web Reputation Computer Activity:** The top five computers with Web Reputation events, including the number of events.
- **Web Reputation Event History [2x1]:** Recent Web Reputation event history, including the events severity.
- **Web Reputation URL Activity:** The top five URLs that triggered Web Reputation events, including the number of times they were accessed.

Firewall:

- **Firewall Activity (Detected):** The top five reasons packets were detected, including the number of times.
- **Firewall Activity (Prevented):** The top five reasons packets were prevented, including the number of times.

- **Firewall Computer Activity (Detected):** The top five computers that generated detected Firewall events and the number of times they occurred.
- **Firewall Computer Activity (Prevented):** The top five computers that generated prevented Firewall events and the number of times they occurred.
- **Firewall Event History [2x1]:** Recent Firewall event history, including if the events were detected or prevented.
- **Firewall IP Activity (Detected):** The top five source IPs that generated detected Firewall events and the number of times they occurred.
- **Firewall IP Activity (Prevented):** The top five source IPs that generated prevented Firewall events and the number of times they occurred.
- **Firewall Port Activity (Detected):** The top five destination ports for detected Firewall events and the number of times they occurred.
- **Firewall Port Activity (Prevented):** The top five computers that generated prevented Firewall events and the number of times they occurred.
- **Reconnaissance Scan Activity:** The top five detected reconnaissance scans, including the number of times they occurred.
- **Reconnaissance Scan Computers:** The top five computers where reconnaissance scans occurred and the number of times they occurred.
- **Reconnaissance Scan History [2x1]:** Recent reconnaissance scan history, including the type of scan that occurred.

Intrusion Prevention:

- **Application Type Activity (Detected):** The top five detected application types, including the number of times they were triggered.
- **Application Type Activity (Prevented):** The top five prevented application types, including the number of times they were triggered.
- **Application Type Treemap (Detected) [2x2]:** A map of detected application types. Hover over the boxes to display the severity of the events, the number of times it was triggered, and the percentage for each severity level.
- **Application Type Treemap (Prevented) [2x2]:** A map of prevented application types. Hover over the boxes to display the severity of the events, the number of times it was triggered, and the percentage for each severity level.
- **IPS Activity (Detected):** The top five reasons Intrusion Prevention events were detected, including the number of times it was triggered.

- **IPS Activity (Prevented):** The top five reasons Intrusion Prevention events were prevented, including the number of times it was triggered.
- **IPS Computer Activity (Detected):** The top five computers with detected Intrusion Prevention events.
- **IPS Computer Activity (Prevented):** The top five computers with prevented Intrusion Prevention events.
- **IPS Event History [2x1]:** Recent Intrusion Prevention event history, including if the events were detected or prevented.
- **IPS IP Activity (Detected):** The top five source IPs that generated detected Intrusion Prevention events.
- **IPS IP Activity (Prevented):** The top five source IPs that generated prevented Intrusion Prevention events.
- **Latest IPS Activity (Detected):** The top five reasons Intrusion Prevention events were detected since the latest update.
- **Latest IPS Activity (Prevented):** The top five reasons Intrusion Prevention events were prevented since the latest update.

Integrity Monitoring:

- **Integrity Monitoring Activity:** The top five reasons Integrity Monitoring events occurred, including the number of times. In this case, the reason refers to the rule that was triggered.
- **Integrity Monitoring Computer Activity:** The top five computers where Integrity Monitoring events occurred, including the number of events.
- **Integrity Monitoring Event History [2x1]:** Recent Integrity Monitoring event history, including the severity of events.
- **Integrity Monitoring Key Activity:** The top five keys for Integrity Monitoring events. The source of the key varies by Entity Set - for files and directories, it is their path, whereas for ports, it is their unique protocol, IP, port number, or tuple.

Log Inspection:

- **Log Inspection Activity:** The top five reasons Integrity Monitoring events occurred, including the number. In this case, the reason refers to the rule that was triggered.
- **Log Inspection Computer Activity:** The top five computers where Log Inspection events occurred, including the number of events.

- **Log Inspection Description Activity:** The top five descriptions for Log Inspection events, including the number of times they occurred. The description refers to the event that was triggered.
- **Log Inspection Event History [2x1]:** Recent Log Inspection event history, including the severity of events.

Application Control:

- **Application Control Maintenance Mode Status [2x1]:** The computers in maintenance mode, including their start and end time.

Change the layout

You can move the selected widgets around the dashboard by dragging them by their title bar. That is, if you move a widget over an existing one, they will exchange places. The widget that is about to be displaced will temporarily gray out.

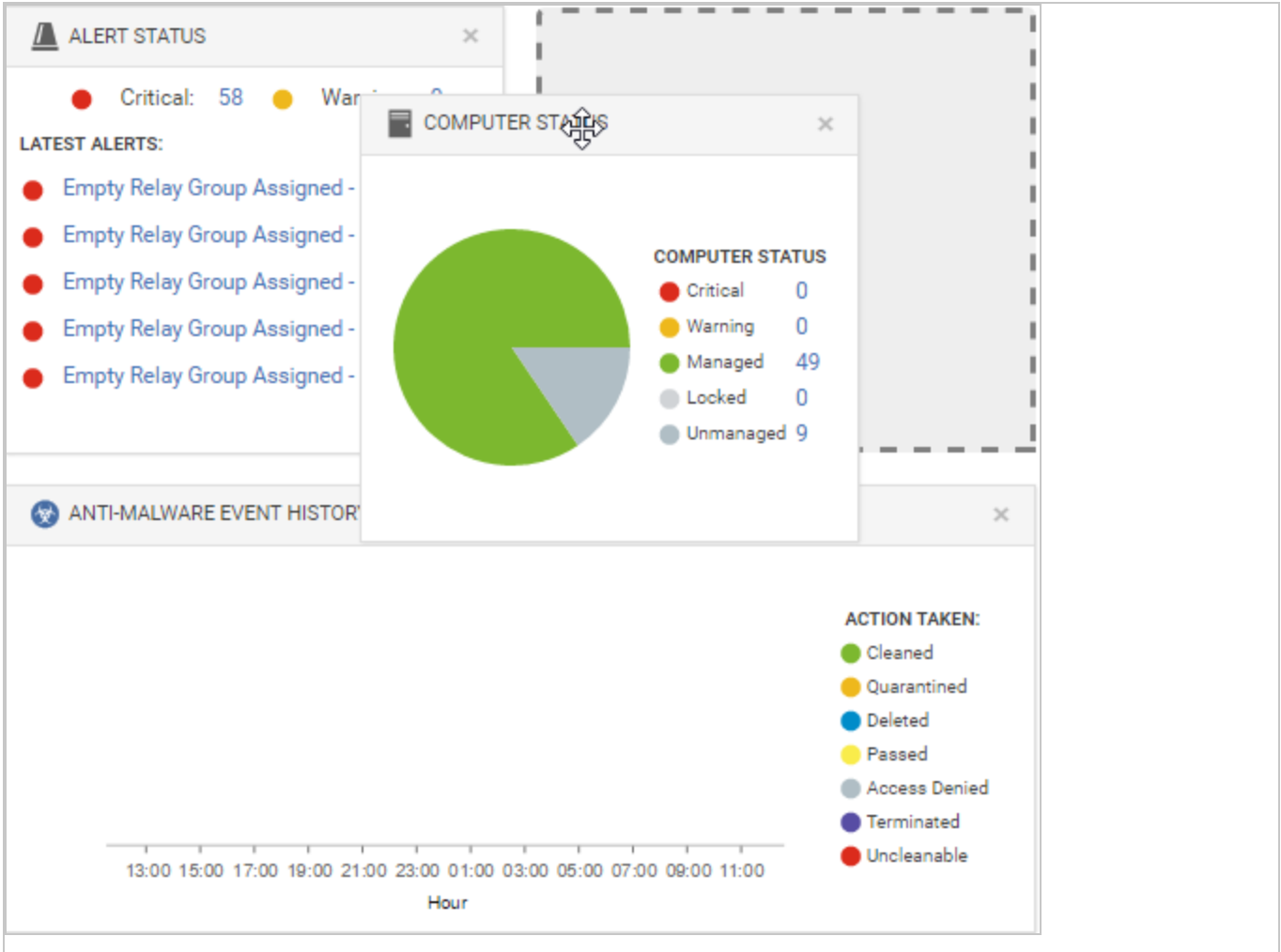

Save and manage dashboard layouts

You can create multiple dashboard layouts and save them as separate tabs. Your Dashboard settings and layouts are not visible to other users after you sign out. To create a new Dashboard tab, click the plus symbol to the right of the last tab on the Dashboard, as per the following illustration:

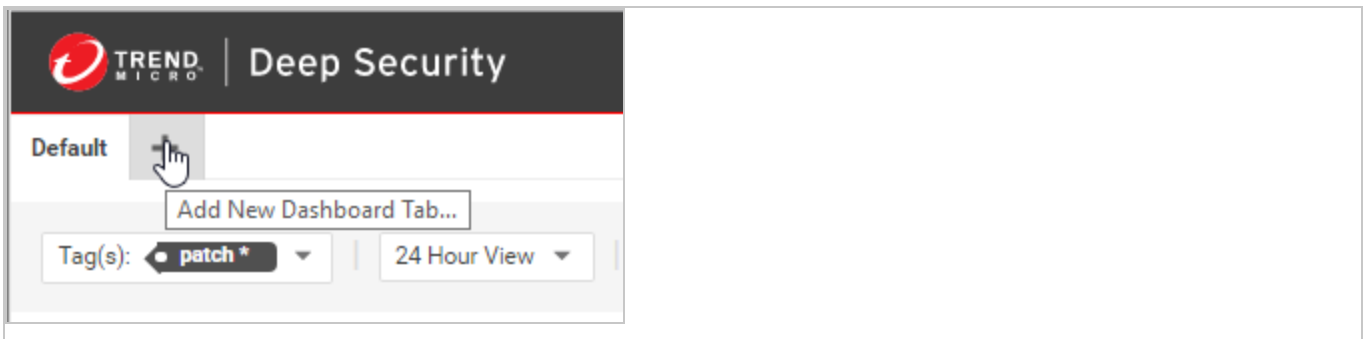

Group computers dynamically with smart folders

A smart folder is a dynamic group of computers that you define with a saved search query. It finds matching computers each time you click the group. For example, if you want to view your computers grouped by attributes such as operating system or AWS project tags, you can do this using smart folders.

Tip: If you prefer to search for resources programmatically, you can automate resource searches using the Deep Security API. For examples, see the [Search for Resources](#) guide in the Deep Security Automation Center.

You create smart folders by defining:

1. What to search (1 - computer properties)
2. How to determine a match (2 - operator)
3. What to search for (3 - value)

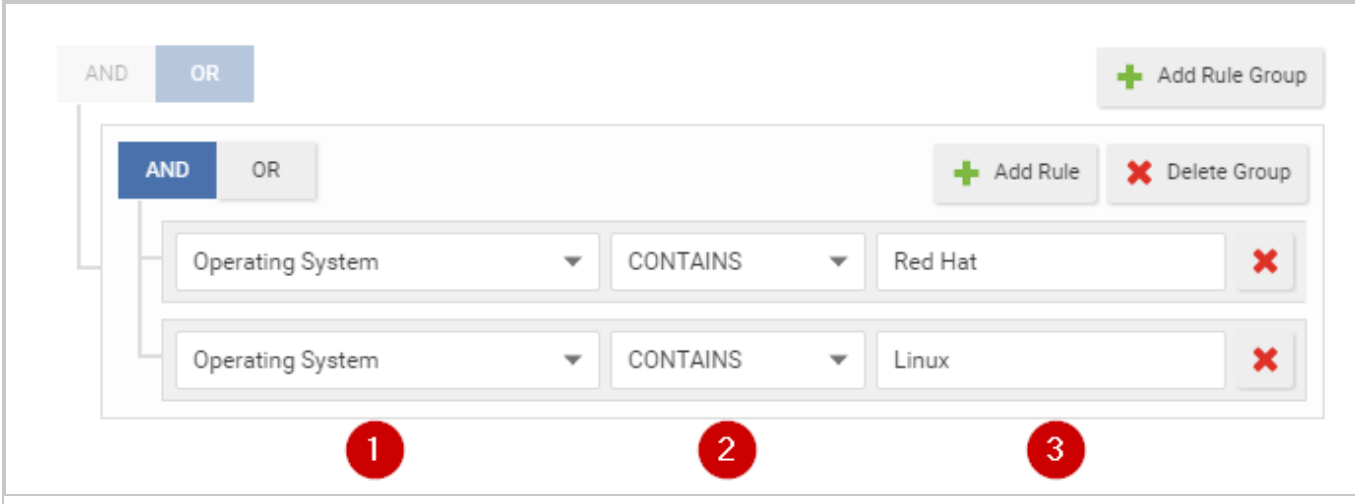

The screenshot displays the configuration interface for a smart folder. At the top, there are two buttons: "AND" and "OR", with "OR" selected. To the right is a "+ Add Rule Group" button. Below this is a nested configuration area with its own "AND" and "OR" buttons, and "+ Add Rule" and "X Delete Group" buttons. Two search rules are defined:

- Rule 1: "Operating System" (property) CONTAINS (operator) "Red Hat" (value). A red circle with the number "1" is positioned below the property field.
- Rule 2: "Operating System" (property) CONTAINS (operator) "Linux" (value). A red circle with the number "2" is positioned below the operator field, and a red circle with the number "3" is positioned below the value field.

Create a smart folder

1. Go to **Computers > Smart Folders**.
2. Click **Create a Smart Folder**.

A default, empty search criteria group ("rule group") appears. You must configure this first. If you need to define more or alternative possible matches, you can add more rule groups later.

3. Type a name for your smart folder.

4. In the first drop-down list, select a property that all matching computers have, such as **Operating System**. (See "[Searchable Properties](#)" on page 1546.)

If you selected **AWS Tag**, **Azure Tag**, or **GCP Label**, also type the tag's name or label key.

5. Select the [operator](#): whether to match identical, similar, or opposite computers, such as **CONTAINS**.

Note: Some operators are not available for all properties.

6. Type all or part of the search term.

Note: Wild card characters are not supported.

Tip: If you enter multiple words, it compares the *entire phrase* - not each word separately. No match occurs if the property's value has words in a different order, or only some of the words.

To match *any* of the words, instead click **Add Rule** and **OR**, and then add another value: one word per rule.

7. If computers must match multiple properties, click **Add Rule** and **AND**. Repeat steps 4-6.

For more complex smart folders, you can chain multiple search criteria. Click **Add Group**, then click **AND** or **OR**. Repeat steps 4-7.

For example, you might have Linux computers deployed both on-premises and in clouds such as AWS or vCloud. You could create a smart folder that contains all of them by using 3 rule groups based on:

- a. local physical computers' operating system
- b. AWS tag
- c. vCenter or vCloud name

Tip: To test the results of your query before saving your smart folder, click **Preview**.

8. Click **Save**.
9. To verify, click your new smart folder. Verify that it contains all expected computers.

Tip: For faster smart folders, remove unnecessary AND operations, and reduce sub-folder depths. They increase query complexity, which reduces performance.

Also verify that it omits computers that shouldn't match the query. If you need to edit your smart folder's query, double-click the smart folder.

Note: If your account's role doesn't have the permissions, some computers won't appear, or you won't be able to edit their properties. For more information, see ["Define roles for users" on page 1488](#).

Edit a smart folder

If you need to edit your smart folder's query, double-click the smart folder.

To reorder search criteria rules or rule groups, move your cursor onto a rule or group until it changes to a , then drag it to its destination.

Clone a smart folder

To duplicate and modify an existing smart folder as a template for a new smart folder, right-click the original smart folder, then select **Copy Smart Folder**.

Focus your search using sub-folders

You can use sub-folders to filter a smart folder's search results.

Smart folders can be nested up to 10 levels deep.

- Smart folder 1
 - Sub-folder 2
 - Sub-folder 3 ...

For example, you might have a smart folder for all your Windows computers, but want to focus on computers that are specifically Windows 7, and maybe specifically either 32-bit or 64-bit. To do this, under the "Windows" parent folder, you could create a child smart folder for Windows 7. Then, under the "Windows 7" folder, you would create two child smart folders: 32-bit and 64-bit.

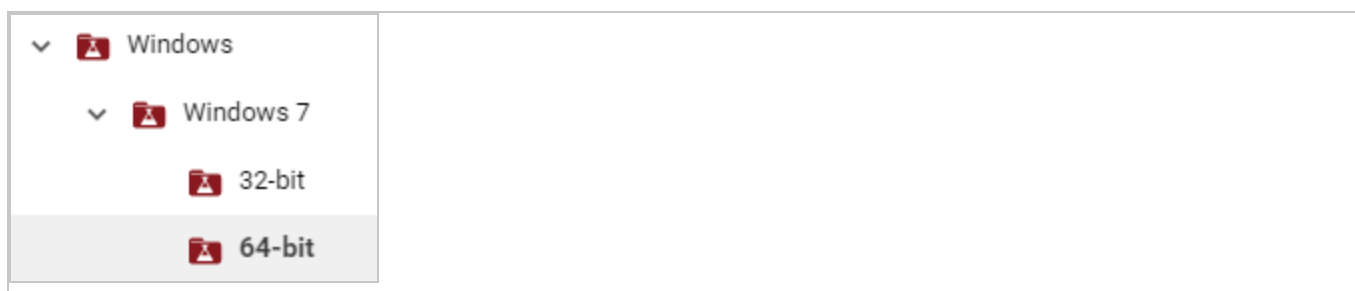

1. Right-click a smart folder and select **Create Child Smart Folder**.
2. Edit your child smart folder's query groups or rules. Click **Save**.
3. Click your new smart folder. Verify that it contains all expected computers. Also verify that it omits computers that shouldn't match the query.

Automatically create sub-folders

Note: Applies to AWS, Azure, and GCP computers only.

Instead of manually creating child folders, you can automatically create sub-folders for each value of an AWS tag, Azure tag, or GCP label that's assigned to an Amazon EC2 instance,

Amazon Workspace, Azure VM, or GCP VM instance. For information on how to apply tags/labels to your computers, refer to the documentation from your cloud provider:

- Amazon: [Tag your Amazon EC2 resources](#), [Tag WorkSpaces Resources](#)
- Azure: [Use tags to organize your Azure resources and management hierarchy](#)
- GCP: [Labeling resources](#).

Note: Tag/label-based sub-folders will replace any existing manually created child folders under the parent folder.

1. In Deep Security Manager, right-click a smart folder and select **Smart Folder Properties**.
2. In the main pane, near the bottom, select the **Automatically create sub-folders for each value of a specific tag or label key** check box.
3. Select either the AWS, Azure, or GCP cloud vendor.
4. Type the name of the AWS tag, Azure tag, or GCP label key. Sub-folders are automatically created for each of the tag or label values.
5. Click **Save**.

Tip: Empty sub-folders can appear if tag or label value is not being used anymore. To remove them, right-click the smart folder and select **Synchronize Smart Folder**.

Searchable Properties

Properties are an attribute that some or all computers you want to find have. Smart folders show computers that have the selected property, and its value matches.

Note: Type your search *exactly as that property appears in Deep Security Manager*- not, for example, vCenter/AWS/Azure/GCP. Otherwise your smart folder query won't match. To find the exact matching text, (unless otherwise noted) go to **Computers** and look in the navigation pane on the left.

General

Property	Description	Data type	Examples
Hostname	The computer's host name, as seen on Computers > Details in Hostname.	string	ca-staging-web1
Computer Display Name	The computer's display name in Deep	string	nginxTest

Property	Description	Data type	Examples
	Security (if any), as seen on Computers > Details in Display Name.		
Folder Name	The computer's assigned group.	string	US-East
Operating System	The computer's operating system, as seen on Computers > Details in Platform.	string	Microsoft Windows 7 (64 bit) Service Pack 1 Build 7601
IP Address	<p>The computer's IP address.</p> <p>You can find the IP address in Deep Security Manager. To find the IP of:</p> <ul style="list-style-type: none"> an AWS instance, GCP VM or Azure VM, that was added to Deep Security through Add > Add AWS Azure GCP Account, go the computer's details page, and under the General tab, scroll to the Virtual machine Summary section. The AWS IP addresses are listed in these fields: <ul style="list-style-type: none"> Private IP Address Public IP (PIP) Address <p>Note: If you added the AWS, GCP, or Azure computer through Add > Add Computers, its IP address is located in the same place as a physical computer's.</p> a physical computer, go to the computer's details page and on 	IPv4 or IPv6 address, or an IPv4 range	172.20.1.5-172.20.1.55 2001:db8:face::5

Property	Description	Data type	Examples
	<p>the left, click Interfaces</p> <p>Note: If "DHCP" is displayed instead of a static IP address, it won't match the smart folder query.</p> <ul style="list-style-type: none"> a vCenter or vCloud VM, go to the vCenter computer's details page, and under the General tab, scroll to the Virtual machine Summary section. The vCenter or vCloud IP address is listed in the IP Address field. 		
Policy	The computer's assigned Deep Security policy, as seen on Computers > Details .	string (option in drop-down list)	Base Policy
Activated	Whether or not the computer has been activated with Deep Security Manager, as seen on Computers > Details .	Boolean	Yes
Docker Host	Whether or not Docker is installed on the computer, as seen on Computers > Details .	Boolean	No
Computer Type	The type of computer. Options are: Physical Computer, Amazon EC2 Instance, Amazon WorkSpace, vCenter VM, Azure Instance, Azure ARM Instance, GCP VM Instance.	string (option in drop-down list)	Examples: Physical Computer, Amazon EC2 Instance
Last Successful Recommendation Scan	Whether or not the computer has had a successful recommendation scan within	Date operator	OLDER THAN, 7, DAYS

Property	Description	Data type	Examples
	a specified time period. The last recommendation scan date and results can be seen on Computers > Details > General > Intrusion Prevention or Integrity Monitoring or Log Inspection > Recommendations .	drop-down list, String, Date unit drop-down list	
Last Agent Communication	Whether or not the agent has communicated with Deep Security Manager within a specified time period. The Last Communication date can be seen on Computers > Details > General > Last Communication .	Date operator drop-down list, String, Date unit drop-down list	OLDER THAN, 3, DAYS
Agent Offline	Whether or not the agent is offline. This is displayed as Managed (Offline) or Offline on Computers > Details > General > Last Communication .	Boolean	Yes
Task(s)	State of the computer's tasks, as displayed in the Task(s) column on the Computers page. For a list of all possible tasks, see " Computer and agent statuses " on page 1424.	string	Activating
Host Created Date	Date when the computer was added to Deep Security Manager.	string (date)	2019-03-15
Version	Deep Security Agent version.	string	12.0.0.1

AWS

Property	Description	Data type	Examples
Tag	The computer's AWS tag key:value pair, as seen on Computers > Details > Overview > General under Virtual machine Summary, in Cloud Instance Metadata. Type the tag name, then its value. Case-sensitive.	string	Tag Key: env Tag Value: staging
Security Group Name	The computer's associated AWS security group name, as seen on Computers > Details > Overview > General under Virtual machine Summary, in Security Group(s).	string	SecGrp1
Security Group ID	The computer's AWS security group ID, as seen on Computers > Details > Overview > General under Virtual machine Summary, in Security Group(s).	string	sg-12345678
AMI ID	The computer's Amazon Machine AMI ID, as seen on Computers > Details > Overview > General under Virtual machine Summary, in AMI ID.	string	ami-23c44a56
Account ID	The computer's associated 12-digit AWS Account ID , as seen on Computers when you right-click Amazon Account and select Properties . Results include computers in sub-folders.	string	123456789012
Account Name	The computer's associated AWS Account Alias , as seen on Computers when you right-click the AWS Cloud Connector and select Properties . Results include computers in sub-folders.	string	MyAccount-123
Region ID	The computer's AWS region suffix . Results include computers in sub-folders.	string	us-east-1
Region Name	The computer's associated AWS region name.	string	US East (Ohio)

Property	Description	Data type	Examples
	Results include computers in sub-folders.		
VPC ID	<p>The computer's Virtual Private Cloud (VPC) ID.</p> <p>If an alias exists, the folder name is the alias, followed by the VPC ID in parentheses. Otherwise the folder's name is the VPC ID.</p> <p>Results include computers in sub-folders.</p>	string	vpc-3005e48a
Subnet ID	<p>The computer's associated Virtual Private Cloud (VPC) subnet ID.</p> <p>If an alias exists, the folder name is the alias, followed by the VPC subnet ID in parentheses. Otherwise the folder's name is the VPC subnet ID.</p> <p>Results include computers in sub-folders.</p>	string	subnet-b1c2e468
Directory ID	<p>The ID of the AWS directory where the user entry associated with an Amazon WorkSpace resides. The directory ID is seen on the Computers > Details > Virtual machine Summary, in the WorkSpace Directory field. That field takes the format <directory_alias>(<directory_ID>), for example, myworkspacedir (d-9367232d89).</p>	string	d-9367232d89

Azure

Property	Description	Data type	Examples
Subscription Name	<p>Note: As of Deep Security Manager 12.0, the Subscription Name is no longer collected. It remains visible in the drop-down list of properties in case the information was obtained through a previous version of the manager.</p>	string	MyAzureAccount

Property	Description	Data type	Examples
	<p>The computer's associated Azure subscription account ID, as seen on Computers when you right-click Azure and select Properties.</p> <p>Results include computers in sub-folders.</p>		
Resource Group	The computer's associated resource group.	string	MyResourceGroup
Location	The computer's location name	string	East US
Tag	<p>The computer's Azure tag key:value pair, as seen on Computers > Details > Overview > General under Virtual machine Summary, in Cloud Instance Metadata.</p> <p>Type the tag name, then its value. Case-sensitive.</p>	string	<p>Tag Key: env</p> <p>Tag Value: staging</p>

GCP

Property	Description	Data type	Examples
Label	<p>The computer's GCP label key:value pair, as seen on Computers > Details > Overview > General under Virtual machine Summary, in Cloud Instance Metadata.</p> <p>Type the label key, and then its value. Case-sensitive.</p>	string	<p>Label Key: env</p> <p>Label Value: staging</p>
Network Tag	The computer's network tag , as seen on Computers > Details > Overview > General under Virtual machine Summary , in Cloud Instance Metadata .	string	production

vCenter

Property	Description	Data type	Examples
Name	The computer's associated vCenter. Results include computers in sub-folders.	string	vCenter - lab13-vc.example.com
Datacenter	The computer's associated vCenter data center. Results include computers in sub-folders.	string	lab13-datacenter
Folder	The computer's vCenter folder. Results include computers in sub-folders.	string	db_dev
Parent ESX Hostname	The hostname of the ESXi hypervisor where the computer's guest VM is running, as seen on Computers .	string	lab13-esx2.example.com
Custom Attribute	The computer's assigned vCenter custom attribute, as seen on Computers > Details in Virtual machine Summary.	string (comma-separated attribute name and value)	env, production
Power State	The computer's vCenter state, as seen on Computers > Details in VMware Virtual machine Summary.	string (option in list)	Powered On

vCloud

Property	Description	Data type	Examples
Name	The computer's associated vCloud.	string	vCloud-lab23

Property	Description	Data type	Examples
	Results include computers in sub-folders.		
Datacenter	The computer's associated vCloud data center. Results include computers in sub-folders.	string	lab13- datacenter
vApp	The computer's associated vCloud data center folder. Results include computers in sub-folders.	string	db_dev

Active Directory

Property	Description	Data type	Examples
Name	The hostname of the Microsoft Active Directory or LDAP directory. Results include computers in sub-folders.	string	ad01.example.com
Folder	The computer's Microsoft Active Directory or LDAP folder name. Results include computers in sub-folders.	string	Computers

Operators

Smart folder operators indicate whether matching computers should have a property value that is identical, similar, or dissimilar to your search term. Not all operators are available for every property.

Operator	Description	Example usage
EQUALS	The search query only finds computers that are an exact match.	A search query for 'Windows' in the Operating System property does not find computers with 'Windows 7' or 'Microsoft Windows'.

Operator	Description	Example usage
DOES NOT EQUAL	The search query finds any computers that are not an exact match.	A search query for 'Amazon Linux (64 bit)' in the Operating System property finds all computers other than Amazon Linux 64-bit machines.
CONTAINS	The search query finds any computers that contain the search term.	A search query for '203.0.113.' in the IP Address property finds any computers on the 203.0.113.xxx subnet.
DOES NOT CONTAIN	The search query finds any computers that do not contain the search term.	A search query for 'Windows' in the Operating System property finds any computers that do not have 'Windows' in their operating system name.
ANY VALUE	The search query finds all computers with the selected property.	A search query in the Group Name property finds all computers in that group.
IN RANGE	The search query finds all computers between the specified start and end range.	A search query in the IP Address property with Start Range 10.0.0.0 and End Range 10.255.255.255 would find all computers with IP addresses between 10.0.0.0 and 10.255.255.255.
NOT IN RANGE	The search query finds all computers that are not between the specified start and end range.	A search query in the IP Address property with Start Range 10.0.0.0 and End Range 10.255.255.255 finds all computers that have IP addresses outside the range of 10.0.0.0 and 10.255.255.255.
Yes	The search query finds all computers with the selected property.	A search query with 'Yes' selected for the Docker property finds any computers with the Docker service running.
No	The search query finds all computers that do not have the selected property.	A search query with 'No' selected for the Docker property would find any computers that do not have the Docker service running.
OLDER THAN	The search query finds all computers	A search query with 'OLDER THAN', '7', 'DAYS' for the 'Last Successful Recommendation Scan'

Operator	Description	Example usage
	<p>prior to the specified date for the property.</p> <p>Used with an accompanying DAYS, WEEKS, HOURS, or MINUTES operator.</p>	<p>property finds computers that have had a successful recommendation scan 8 days or longer ago.</p>
MORE RECENTLY THAN	<p>The search query finds all computers more recent than the specified date for the property.</p> <p>Used with an accompanying DAYS, WEEKS, HOURS, or MINUTES operator.</p>	<p>A search query with 'MORE RECENTLY THAN', '1', 'MONTH' for the 'Last Successful Recommendation Scan' property finds computers that have had a successful recommendation scan earlier than 1 month ago.</p>
NEVER	<p>The search query finds all computers that do not match the property.</p>	<p>A search query with 'NEVER' for the 'Last Successful Recommendation Scan' property finds computers that have never had a successful recommendation scan.</p>

Customize advanced system settings

Several features for advanced users are located on **Administration > System Settings > Advanced**.

Tip: You can automate system setting changes using the Deep Security API. For examples, see the [Configure Policy, Computer, and System Settings](#) guide in the Deep Security Automation Center.

Primary Tenant Access

By default, the primary tenant can access your Deep Security environment.

If the primary tenant enabled the "Primary Tenant Access" settings in your environment, however, you can prevent the primary tenant from accessing your Deep Security environment, or grant access for a limited amount of time.

Load Balancers

Note: The load balancer settings are not available when FIPS mode is enabled. See "[FIPS 140 support](#)" on page 1811.

Agents are configured with a list of Deep Security Manager and Deep Security Relays. When multiple managers and relays are deployed *without* a [load balancer](#), agents will automatically contact the managers and relays using a round robin sequence.

To better scale your network, you can put a load balancer in front of the managers or relays. When you configure the load balancer hostname and [port numbers](#), it will override the IP address or hostname and port numbers currently used by the agents.

The script generator uses the address of the Deep Security Manager that you are connected to. This ensures that the scripts continue to function even if one of the Deep Security Manager nodes fails or is down for maintenance or upgrades.

Note: The load balancer must be non-terminating for the SSL or TLS session with the agent's heartbeat port number because it uses mutual authentication. SSL inspection that terminates (for example, if you try to use SSL offloading) will break the session.

Multi-tenant Mode

1. Select **Enable Multi-Tenant Mode**.
2. In the wizard that appears, enter your **Multi-Tenant Activation Code** and click **Next**.
3. Select the license mode, either:
 - **Inherit Licensing from Primary Tenant:** All tenants use the same licenses as the primary tenant.
 - **Per Tenant Licensing:** Tenants themselves enter a license when they log in for the first time.

4. Click **Next**.

Deep Security Manager Plug-ins

Plug-ins are modules, reports and other add-ons for the Deep Security Manager. Trend Micro occasionally produces new or additional versions of these which are distributed as self-installing packages.

SOAP Web Service API

Enable or disable the legacy SOAP API Web services. The WSDL (Web Services Description Language) can be found at the URL displayed in the panel on the page. For more information about APIs, see ["Use the Deep Security API to automate tasks" on page 1764](#).

Note: To access the Web Services APIs, a user must be assigned a role with the appropriate access rights. To configure the role, go to **Administration > User Management > Roles**, open the role properties, and select **Allow Access to web services API**.

Status Monitoring API

Enable or disable the Status Monitoring API of the legacy REST API. This API lets you query the Deep Security Manager (including individual Manager Nodes) for status information such as CPU and memory usage, number of queued jobs, total and Tenant-specific database size. For more information about APIs, see ["Use the Deep Security API to automate tasks" on page 1764](#).

Export

Export file character encoding: The character encoding used when you export data files from the Deep Security Manager. The encoding must support characters in your chosen language.

Exported Diagnostics Package Language: Your support provider may ask you generate and send them a Deep Security diagnostics package. This setting specifies the language the package will be in. The diagnostic package is generated on **Administration > System Information**.

Whois

Whois can be used to look up which domain name is associated with an IP address when you review logged intrusion prevention and firewall events. Enter the search URL using "[IP]" as a placeholder for the IP address to look up.

(For example, "http://reports.internic.net/cgi/whois?whois_nic=[IP]&type=nameserver".)

Licenses

Hide unlicensed Protection Modules for new Users determines whether unlicensed modules are hidden rather than simply grayed out for subsequently created Users. (This setting can be overridden on a per-user basis on **Administration > User Management > Users > Properties**).

Click **View Scan Cache Configurations** to display a list of saved Scan Cache Configurations. Scan Cache Configurations are settings used by the Virtual Appliance to maximize the efficiency of Anti-Malware and Integrity Scans in a virtualized environment. See "[Virtual Appliance Scan Caching](#)" on page 1035 for more information.

CPU Usage During Recommendation Scans

This setting controls the amount of CPU resources dedicated to performing Recommendation Scans. If you notice that CPU usage is reaching unreasonably high levels, try changing to a lower setting to remedy the situation. For other performance controls, see **Administration > Manager Nodes > Properties > Performance Profiles**.

NSX

If Deep Security is being used to protect virtual machines in a VMware NSX environment and if it is installed with multiple Deep Security Manager nodes, this setting will determine which Deep Security Manager node communicates with the NSX Manager. (For more information on integrating Deep Security with an NSX environment, see "[Install Deep Security Manager](#)" on page 442. For more information on multiple Deep Security Manager Nodes, see "[Install Deep Security Manager on multiple nodes](#)" on page 488.

Logo

You can replace the Deep Security logo that appears on the login page, at the top right of the Deep Security Manager GUI, and at the top of reports. Your replacement image must be in PNG

format, be 320 px wide and 35 px high, and have a file size smaller than 1 MB. A template is available in the `installfiles` directory of the Deep Security Manager.

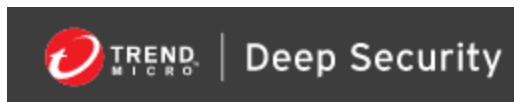

Click **Import Logo** to import your own logo, or click **Reset Logo** to reset the logo to its default image.

Manager AWS Identity

You can configure cross-account access. Select either:

- **Use Manager Instance Role:** The more secure option to configure cross-account access. Attach a policy with the `sts:AssumeRole` permission to the Deep Security Manager's instance role, then select this option. Does not appear if the Deep Security Manager does not have an instance role, or if you're using an Azure Marketplace or on-premise installation of Deep Security Manager.
- **Use AWS Access Keys:** Create the keys and attach a policy with the `sts:AssumeRole` permission before you select this option, and then type the **Access Key** and **Secret Key**. Does not appear if you're using an Azure Marketplace or on-premise installation of Deep Security Manager.

Application control

Each time you create an [Application Control](#) ruleset or change it, it must be distributed to all computers that use it. Shared rulesets are bigger than local rulesets. Shared rulesets are also often applied to many servers. If they all downloaded the ruleset directly from the manager at the same time, high load could cause slower performance. Global rulesets have the same considerations.

Using Deep Security Relays can solve this problem. (For information on configuring relays, see ["Deploy additional relays" on page 1415.](#))

Steps vary by whether or not you have a multi-tenant deployment.

Single tenant deployments

Go to **Administration > System Settings > Advanced** and then select **Serve Application Control rulesets from relays**.

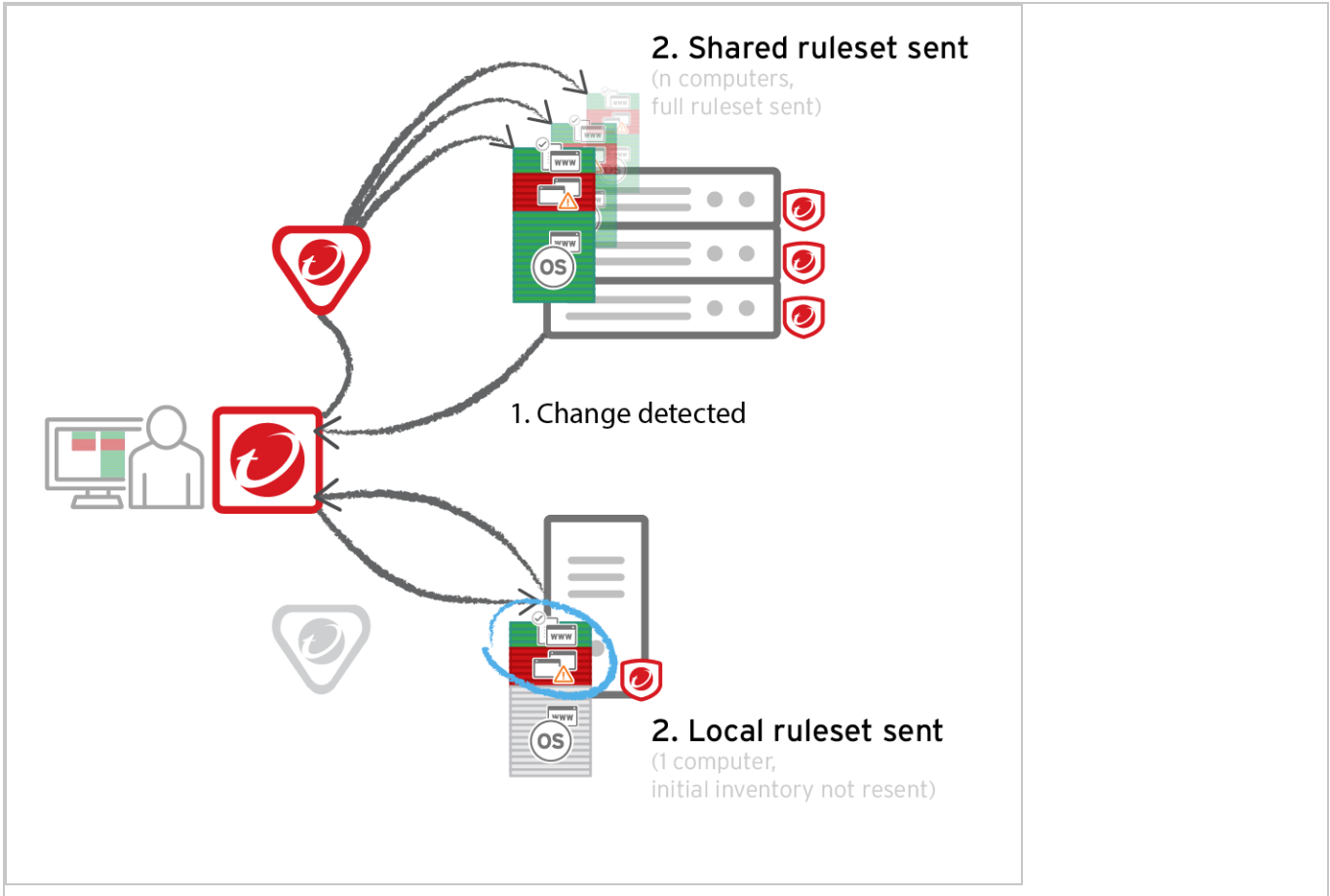

Multi-tenant deployments

The primary tenant (t0) can't access other tenants' (tN) configurations, so t0 relays don't have tN Application Control rulesets. (Other features like IPS don't have this consideration, because their rules come from Trend Micro, not a tenant.)

Other tenants (Tn) must create their own [relay group](#), then select **Serve Application Control rulesets from relays**.

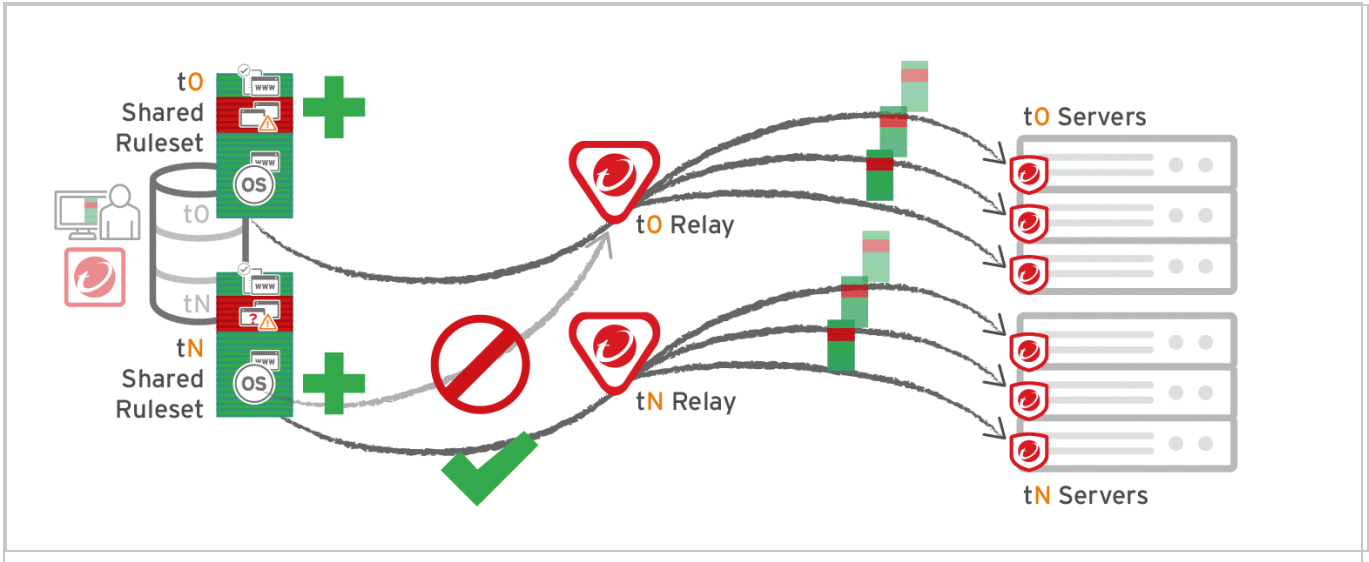

Warning:

Verify compatibility with your deployment before using relays. If the agent doesn't have any previously downloaded rulesets currently in effect, and if it doesn't receive new **Application Control rules**, then the computer won't be protected by Application Control. If an Application Control ruleset fails to download, a [ruleset download failure event will be recorded on the manager](#) and [on the agent](#).

Relays might either change performance, break Application Control ruleset downloads, or be required; it varies by proxy location, multi-tenancy, and global/shared vs. local rulesets.

Required for...	Faster performance for...	Slower performance for...	Don't enable for...
Agent > Proxy > Manager Note: In Deep Security Agent 10.0 GM	Shared rulesets Global ruleset	Local rulesets	Multi-tenant configurations when non-primary tenants (tN) use the default, primary (t0) relay group: <ul style="list-style-type: none"> • Agent (tN) > DSR (t0) > DSM (tN) • Agent (tN) > Proxy > DSR (t0) > DSM (tN)

Required for...	Faster performance for...	Slower performance for...	Don't enable for...
<p>and earlier, agents didn't have support for connections through a proxy to relays. If a ruleset download fails due to a proxy, and if your agents require a proxy to access the relay or manager, then you must either:</p> <ul style="list-style-type: none"> • upd 			

Required for...	Faster performance for...	Slower performance for...	Don't enable for...
<p>ate agents' software, then configure the proxy</p> <ul style="list-style-type: none"> • bypass the proxy • add a relay and then select Server Application Control 			

Required for...	Faster performance for...	Slower performance for...	Don't enable for...
rule sets from relays			

Harden Deep Security

About Deep Security hardening

There are several measures you can take to increase the security of your Deep Security deployment.

- ["Protect Deep Security Manager with an agent" on the next page](#)
- ["Protect Deep Security Agent" on page 1567](#)
- ["Replace the Deep Security Manager TLS certificate" on page 1570](#)
- ["Update the load balancer's certificate" on page 1580](#)
- ["Encrypt communication between the Deep Security Manager and the database" on page 1582](#)
- ["Change the Deep Security Manager database password" on page 1588](#)
- ["Configure HTTP security headers" on page 1590](#)
- ["Upgrade the Deep Security cryptographic algorithm" on page 1595](#)
- ["Enforce user password rules" on page 1597](#)
- ["Set up multi-factor authentication" on page 1599](#)
- ["Manage trusted certificates" on page 1603](#)
- ["SSL implementation and credential provisioning" on page 1606](#)

Protect Deep Security Manager with an agent

To protect the server where Deep Security Manager is installed, install an agent on it and apply the Deep Security Manager policy.

1. Install an agent on the same computer as the manager.
2. Go to **Computers**.
3. Add the manager's computer. Do not choose to apply a policy yet.
4. Turn on the **Intrusion Prevention** with no rule. Double-click the new computer to display its **Details** window and go to **Intrusion Prevention > General > Configuration > On**.
5. Wait for the **Intrusion Prevention** to turn on.
6. Go to **Intrusion Prevention > Advanced > SSL Configurations**.
7. Click **View SSL Configurations > New** to start the wizard to create a new SSL Configuration.
8. Specify the interface used by the manager. Click **Next**.
9. On the **Port** page, select whether to protect the Deep Security Manager GUI's port number. (See [the port number](#).) Click **Next**.
10. Specify whether SSL Intrusion Prevention analysis should take place on all IP addresses for this computer, or just one. (This feature can be used to set up multiple virtual computers on a single computer.)
11. Select **Use the SSL Credentials built into the Deep Security Manager**. (This option only appears when creating an SSL Configuration for the Manager's computer.) Click **Next**.
12. Finish the wizard and close the **SSL Configuration** page.
13. Return to the computer's **Details** window. Apply the **Deep Security Manager Policy**, which includes the Firewall Rules and Intrusion Prevention Rules required to protect the Deep Security Manager's GUI port number.

You have now protected the Manager's computer and are now filtering the traffic (including SSL) to the Manager.

Note: After configuring the Agent to filter SSL traffic, you may notice that the Deep Security Agent will return several **Renewal Error** events. These are certificate renewal errors caused by the new SSL certificate issued by the Manager computer. To fix this, refresh the web page and reconnect to the Deep Security Manager's GUI.

The **Deep Security Manager** Policy has the basic Firewall Rules assigned to enable remote use of the Manager. Additional Firewall Rules may need to be assigned if the Manager's computer is being used for other purposes. The Policy also includes the Intrusion Prevention Rules in the

Web Server Common Application Type. Additional Intrusion Prevention Rules can be assigned as desired.

Because the **Web Server Common** Application Type typically filters on the HTTP Port List and does not include the Deep Security Manager GUI's port number, it is added as an override to the ports setting in the **Intrusion Prevention Rules** page of the Policy's **Details** window. (See "[Port numbers, URLs, and IP addresses](#)" on page 410.)

For more information on SSL data inspection, see "[Inspect TLS traffic](#)" on page 910.

Protect Deep Security Agent

To improve security, you can bind Deep Security Agent to a specific Deep Security Manager. The instructions vary depending on if you're using manager-initiated activation or agent-initiated activation. Follow the instructions below, depending on your environment:

Manager-initiated activation

During agent-manager communications, Deep Security Agent can authenticate the identity of its manager. It does this by comparing your trusted manager's certificate to the connecting manager's certificate. If they don't match, manager authentication fails and the agent won't connect.

This prevents agents from activating with or connecting to a malicious server that is pretending to be your Deep Security Manager. This is recommended especially if agents connect through an untrusted network such as the Internet.

To do this, you must configure each agent with the trusted manager's server certificate so that they can recognize their authorized manager *before* they try to connect.

Note: If you reset or deactivate an agent, it deletes the Deep Security Manager certificate. Repeat these steps if you want to reactivate the agent.

1. On Deep Security Manager, run the command to export its server certificate:

```
dsm_c -action exportdsmcert -output ds_agent_dsm.crt [-tenantname TENANTNAME | -tenantid TENANTID]
```

where:

- `ds_agent_dsm.crt` is the name of the manager's server certificate.

Note: You must use this exact file name. You cannot rename it.

- `-tenantname TENANTNAME` is the name of a Deep Security tenant. If the Deep Security Manager is multi-tenant, either this or the `-tenantid` parameter is required. See also "[Set up a multi-tenant environment](#)" on [page 461](#).
- `-tenantid TENANTID` is the ID of a tenant.

If you have multiple tenants, run the command to export the first tenant's certificate, like this:

```
dsm_c -action exportdsmcert -output ds_agent_dsm.crt -
tenantname TENANT1
```

and then continue to the next step. (*Don't* run the export command again for TENANT2 and others *until* you are finished with the certificate for TENANT1. The command will overwrite the file.)

2. On each agent's computer, put the `ds_agent_dsm.crt` file in this folder:
 - Windows: `%ProgramData%\Trend Micro\ Deep Security Agent\dsa_core`
 - Linux: `/var/opt/ds_agent/dsa_core`

If you have multiple tenants, copy each tenant's certificate file only to its own agents. Agents cannot be activated by other tenants.

3. If you have a multi-tenant Deep Security Manager, repeat the previous 2 steps for each tenant.

Note: Initially, after completing these steps, the agent enters a 'pre-activated' state. Until the agent is fully activated, operations initiated by other Deep Security Managers or by entering commands to the agent via `dsa_control` do not work. This is intentional. Normal operation resumes upon activation.

During agent activation, Deep Security Agent can authenticate the identity of its Deep Security Manager by pinning the manager's certificate to the agent. It does this by validating the connecting manager's certificate path and ensuring it is signed by a trusted Certificate Authority (CA). If the certificate path is validated, the manager authentication passes and activates the agents. This prevents agents from activating with a malicious server that is pretending to be your Deep Security Manager.

To protect your agents, you must configure each agent so that they can recognize their authorized manager before they try to activate.

Import a Deep Security Manager certificate chain issued by a public CA

1. Prepare a chain.pem file based on the following specifications:
 - A private key in [PKCS #8](#) format.
 - The X509 certificate that corresponds to the above private key.
 - Any other intermediate X509 certificates to build a chain of trust from the above to certificate to a trusted certificate authority (CA) root. Each certificate must sign the certificate that directly precedes it, so the order is important. See certificate_list in the [RFC](#).

2. On Deep Security Manager, run the following command to import the certificate chain:

```
/opt/dsm/dsm_c -action agentHBPublicServerCertificate -set  
${path_to_pem_file}
```

Note: The `${path_to_pem_file}` must be an absolute path, not relative.

3. Copy the public CA certificate and rename it `ds_agent_dsm_public_ca.crt`.
4. On the agent computer, place the `ds_agent_dsm_public_ca.crt` file in one of these locations:
 - **Windows:** `%ProgramData%\Trend Micro\Deep Security Agent\dsa_core`
 - **Linux/Unix:** `/var/opt/ds_agent/dsa_core`

Note: If you've installed Deep Security Manager 20.0.262 and are activating Deep Security Agent 20.0.1540 or a newer agent, the following error message appears upon

activation, which indicates you have not pinned the manager's certificate to the agent:

```
[Warning/2] | SSLVerifyCallback() - verify error 20: unable to get local issuer certificate
```

Pinning a trusted certificate is optional, so you can ignore this error if it doesn't apply to you. However, if you'd like to use a trusted certificate, follow the steps in the section above before activating the Deep Security Agent.

Confirm the certificate chain is imported

To confirm the certificate chain is imported, enter the following command:

```
/opt/dsm/dsm_c -action agentHBPublicServerCertificate -isSet
```

Delete the imported certificate chain

If you'd like to stop using a Deep Security Manager certificate chain issued by a public CA, enter the following command:

```
/opt/dsm/dsm_c -action agentHBPublicServerCertificate -delete
```

By default, the Deep Security Manager will revert to using a self-signed certificate.

Replace the Deep Security Manager TLS certificate

During installation, Deep Security Manager automatically generates a self-signed X.509 certificate so that you can use TLS during your first connection to the console. Because web browsers do not know this self-signing certificate authority (CA), they cannot validate the certificate's signature, and therefore do not automatically trust it. The browser displays a security alert and asks you to manually validate the certificate in order to connect. To avoid this each time an administrator connects, you can replace this default certificate with a certificate from a trusted CA.

Warning: If you replace the default certificate with an invalid certificate or it has an incomplete [certificate signing chain](#), then you will not be able to connect to the Deep Security Manager console until you correct it. Before replacing the certificate, carefully read the instructions.

Note: The certificates are kept when you upgrade Deep Security Manager. You do not need to upload them again.

To replace the certificate, either:

- **Request a new certificate for the Deep Security Manager domain name**

- a. If FIPS mode is enabled (see ["FIPS 140 support" on page 1811](#)), then disable FIPS mode before you begin to replace the certificate.
- b. ["Generate the private key and Java keystore" below](#).
- c. ["Request a signed certificate \(CSR\)" on page 1574](#).
- d. ["Import the signed certificate into the keystore" on page 1575](#).
- e. ["Configure Deep Security Manager to use the keystore" on page 1577](#).
- f. If you disabled FIPS mode in the first step, re-enable FIPS mode now.

- **Use an existing Java keystore file or certificate**

If you have a certificate file backup from a previous installation, or if you already have a certificate because you use the same certificate for multiple domain names (a [wildcard certificate](#) such as `*.example.com`, or a [multiple-domain/Subject Alternative Name \(SAN\) field certificate](#)), then you can use it instead.

- a. If FIPS mode is enabled (see ["FIPS 140 support" on page 1811](#)), then disable FIPS mode before you begin to replace the certificate.
- b. Verify that you have the complete certificate signing chain. If necessary, ask the CA that issued your certificate.
- c. ["Configure Deep Security Manager to use the keystore" on page 1577](#).
- d. If you disabled FIPS mode in the first step, re-enable FIPS mode now.

Generate the private key and Java keystore

Many public and private CAs have a website that can generate a public and private key pair and certificate signing request (CSR) at the same time. For example, you can [generate the key pair and CSR at the same time in Microsoft Active Directory](#) or an `openssl` CA, and then download and [import the PKCS #12 file](#) with both the signed certificate and private key into the Java keystore.

If you want to do that, then skip the next steps and ["Request a signed certificate \(CSR\)" on page 1574](#), and then continue with ["Import the signed certificate into the keystore" on page 1575](#). Otherwise, use these steps to locally generate the files.

1. On the computer where Deep Security Manager is running, open a command prompt as an administrator.
2. Enter the commands to generate a new private key and keystore file.

In the following command example, the keystore entry (alias) for the new private key is named `tomcat`.

Note:

A certificate's Common Name (CN) or Subject Alternative Name (SAN) field often must be different from the domain name that appears in your browser's location bar.

For example, the URL in your browser's location bar might show

`https://dsm2.infosec.example.com`, but you want to use the same certificate for all of your Deep Security Manager nodes, so you make a wild card certificate with the common name (CN) `*.infosec.example.com`.

• **Linux:**

```
cd /opt/dsm/jre/bin
keytool -genkey \
  -alias tomcat \
  -keystore ~/.keystore \
  -keyalg RSA \
  -validity 365 \
  -keysize 2048 \
  -dname "cn=dsm.example.com, ou=IT, o=Trend Micro,
  l=Ottawa, s=Ontario, c=CA"
```

• **Windows:**

```
cd "C:\Program Files\Trend Micro\Deep Security
Manager\jre\bin"
keytool -genkey ^
  -alias tomcat ^
```

```
-keystore C:\Users\Administrator\.keystore ^
-keyalg RSA ^
-validity 365 ^
-keysize 2048 ^
-dname "cn=dsm.example.com, ou=IT, o=Trend Micro,
l=Ottawa, s=Ontario, c=CA"
```

Note: The example command uses Command Prompt (cmd.exe) syntax. If you use PowerShell instead, then replace the carrets (^) with backticks (`).

For more information about the `keytool` command, see the [Java keytool documentation](#).

3. Enter a password that Deep Security Manager will use to access the keystore. In the example commands, this is shown as `YOUR_PASSWORD`.
4. Enter the command to export the keystore in PKCS #12 format.

In this command example, the name of the exported file is `.YOUR_PKCS12_EXPORTED_KEYSTORE`.

- **Linux:**

```
keytool -importkeystore \
-srckeystore ~/.keystore \
-destkeystore ~/.YOUR_PKCS12_EXPORTED_KEYSTORE \
-deststoretype pkcs12
```

- **Windows:**

```
keytool -importkeystore ^
-srckeystore C:\Users\Administrator\.keystore ^
-destkeystore "C:\Users\Administrator\.YOUR_PKCS12_
EXPORTED_KEYSTORE" ^
-deststoretype pkcs12
```

When prompted, enter a new password for the exported (destination) keystore, and then the password for the original (source) keystore.

5. Continue with ["Request a signed certificate \(CSR\)" on the next page](#).

Request a signed certificate (CSR)

Certificate signing request (CSR) files contain your unsigned certificate and public key. Ask a CA that your web browser trusts to sign it. The CA that signs your certificate can be either a root CA that is directly trusted by web browsers, or any intermediary CA that is directly or indirectly trusted by a root CA.

1. Enter the command to use the PKCS #12 file to generate a CSR file.

You can create a multiple-domain/Subject Alternative Name (SAN) certificate by specifying matching domain names and/or IP addresses in the `san=` field of the `-ext` extension parameter. If you don't need a SAN certificate, then omit the `-ext` parameter.

For a multiple-domain/SAN certificate, browsers should ignore the CN field when validating the connection. Instead they use the SAN field that contains the comma-separated list of matching domain names and IP addresses. Required syntax is shown in the example command.

- **Linux:**

```
keytool -certreq \  
-alias tomcat \  
-keystore ~/.YOUR_PKCS12_EXPORTED_KEYSTORE \  
-file YOUR_CSR.csr \  
-keyalg RSA \  
-ext  
san=dns:dsm.example.com,dns:*.example.org,ip:10.10.10.5
```

- **Windows:**

```
keytool -certreq ^  
-alias tomcat ^  
-keystore C:\Users\Administrator\YOUR_PKCS12_EXPORTED_  
KEYSTORE ^  
-file YOUR_CSR.csr ^  
-keyalg RSA ^  
-ext  
san=dns:dsm.example.com,dns:*.example.org,ip:10.10.10.5
```

2. Upload the CSR file to your CA. When the request has been processed, download the signed certificate file.

3. If you used an intermediary CA, and if your certificate is **not** in PKCS #7 format (it does not contain the signing chain), then also download the CA certificate and the certificates of all other CAs (if any) between it and the root CA.
4. Continue with "[Import the signed certificate into the keystore](#)" below.

Import the signed certificate into the keystore

Note:

Browsers use the list of CA signatures that is added to the certificate (signing chain/chain of trust), to validate the certificate and determine if it is safe for you to connect. It evaluates each CA certificate in order. **You must import all of the CA certificates in the correct order, as shown in the following instructions.**

If the list of signatures is not in order, then web browsers cannot validate your certificate, and will block the connections to the console until you correct it.

1. If the root CA is already in the keystore, skip this step. Otherwise enter the command to import it.

Tip:

If you don't know what is in the keystore, you can view the contents:

```
keytool -list -v
```

In this command example, the certificates are in .crt format and the keystore entry (alias) for the root CA is named `rootCA`.

• Linux:

```
keytool -import \  
-alias rootCA \  
-file ~/YOUR_ROOT_CA.crt \  
-keystore ~/.YOUR_PKCS12_EXPORTED_KEYSTORE \  
-storepass YOUR_PASSWORD
```

• Windows:

```
keytool -import ^  
-alias rootCA ^
```

```
-file c:\Users\Administrator\YOUR_ROOT_CA.crt ^
-keystore c:\Users\Administrator\YOUR_PKCS12_EXPORTED_
KEYSTORE ^
-storepass YOUR_PASSWORD
```

2. If your intermediary CAs (if any) are already in the keystore, skip this step. Otherwise enter the commands to import them. Start with the one that was signed by the root CA, and end with the one that signed your certificate.

- **Linux:**

```
keytool -import \
-alias intermediateCA \
-trustcacerts \
-file ~/YOUR_INTERMEDIARY_CA.crt \
-keystore ~/.YOUR_PKCS12_EXPORTED_KEYSTORE \
-storepass YOUR_PASSWORD
```

- **Windows:**

```
keytool -import ^
-alias intermediateCA ^
-trustcacerts ^
-file c:\Users\Administrator\YOUR_INTERMEDIARY_CA.crt ^
-keystore c:\Users\Administrator\YOUR_PKCS12_EXPORTED_
KEYSTORE ^
-storepass YOUR_PASSWORD
```

3. Enter the command to import your signed certificate.

- **Linux:**

```
keytool -import \
-alias tomcat \
-trustcacerts \
-file ~/YOUR_SIGNED_CERTIFICATE.crt \
-keystore ~/.YOUR_PKCS12_EXPORTED_KEYSTORE \
-storepass YOUR_PASSWORD
```

- **Windows:**

```
keytool -import ^  
-alias tomcat ^  
-trustcacerts ^  
-file c:\Users\Administrator\YOUR_SIGNED_CERTIFICATE.crt ^  
-keystore c:\Users\Administrator\YOUR_PKCS12_EXPORTED_KEystore ^  
-storepass YOUR_PASSWORD
```

If the import is successful, then this message appears:

Certificate reply was installed in keystore

4. Continue with ["Configure Deep Security Manager to use the keystore"](#) below.

Configure Deep Security Manager to use the keystore

1. Enter the commands to back up the configuration and old keystore files, replace the keystore file, and then update the keystore password:

- **Linux:**

```
cp /opt/dsm/configuration.properties  
/opt/dsm/configuration.properties.bak  
  
cp /opt/dsm/.keystore /opt/dsm/.keystore.bak  
  
cp ~/.YOUR_PKCS12_EXPORTED_KEystore /opt/dsm/.keystore
```

- **Windows:**

```
copy "C:\Program Files\Trend Micro\Deep Security  
Manager\configuration.properties" "C:\Program Files\Trend  
Micro\Deep Security Manager\configuration.properties.bak"  
  
copy "C:\Program Files\Trend Micro\Deep Security  
Manager\keystore" "C:\Program Files\Trend Micro\Deep  
Security Manager\keystore.bak"
```

```
copy "c:\Users\Administrator\YOUR_PKCS12_EXPORTED_
KEYSTORE" "C:\Program Files\Trend Micro\Deep Security
Manager\.keystore"
```

Note: You **must** overwrite the default keystore file in its original location. Don't configure the path to point to a new filename or different location instead. Deep Security Manager upgrades do not keep keystore path changes, and this will undo the change.

2. In a plaintext editor, open the `configuration.properties` file and update the keystore password setting:

```
keystorePass=YOUR_PASSWORD
```

3. Restart the Deep Security Manager service.
4. To verify that the manager now uses the new certificate, open a web browser and connect to the Deep Security Manager console. Click the padlock icon in the location bar and examine the certificate details such as its fingerprint (SHA-256 signature).

Regenerate self-signed certificates in Deep Security Manager (summary)

Before regenerating a self-signed certificate, you need to backup the old `.keystore` by executing the following commands:

Linux:

```
cp /opt/dsm/configuration.properties /opt/dsm/configuration.properties.bak
cp /opt/dsm/.keystore /opt/dsm/.keystore.bak
```

Windows:

```
copy "C:\Program Files\Trend Micro\Deep Security
Manager\configuration.properties" "C:\Program Files\Trend Micro\Deep
Security Manager\configuration.properties.bak"
```

```
copy "C:\Program Files\Trend Micro\Deep Security Manager\.keystore"
"C:\Program Files\Trend Micro\Deep Security Manager\.keystore.bak"
```

Create a new `.keystore`, as follows:

- **Linux:**

- a. On the computer where Deep Security Manager is installed, open the command prompt as an administrator and navigate to the `/opt/dsm/jre/bin` directory.
- b. Execute the following command, replacing the `cn` value to match your Deep Security Manager:

```
keytool -genkey -alias tomcat -keystore ~/.keystore -  
keyalg RSA -validity 365 -keysize 2048 -dname  
"cn=dsm.example.com, ou=IT, o=Trend Micro, l=Ottawa,  
s=Ontario, c=CA"
```

- c. When prompted, enter a password that you will later set in the `/opt/dsm/configuration.properties` file for the `keystorePass` value.
- d. When prompted, enter a key password for tomcat or press Enter to have the same key as the keystore file.
- e. Copy the new keystore to the correct location by executing the following command:

```
cp ~/.keystore /opt/dsm/.keystore
```

- f. In the `/opt/dsm/configuration.properties` file, set the keystore password for the `keystorePass` value, and then save the file.
- g. Restart Deep Security Manager.
- h. Verify that the browser can validate the certificate.

- **Windows:**

- a. On the computer where Deep Security Manager is installed, open the command prompt as an administrator and navigate to the `C:\Program Files\Trend Micro\Deep Security Manager\jre\bin` directory.
- b. Execute the following command, replacing the `cn` value to match your Deep Security Manager:

```
keytool -genkey -alias tomcat -keystore  
C:\Users\Administrator\.keystore -keyalg RSA -validity 365  
-keysize 2048 -dname "cn=dsm.example.com, ou=IT, o=Trend  
Micro, l=Ottawa, s=Ontario, c=CA"
```

- c. When prompted, enter a password that you will later set in the `C:\Program Files\Trend Micro\Deep Security Manager\configuration.properties` file for the `keystorePass` value.
- d. When prompted, enter a key password for tomcat or press Enter to have the same key as the keystore file.
- e. Copy the new keystore to the correct location by executing the following command:

```
copy "c:\Users\Administrator\.keystore" "C:\Program Files\Trend Micro\Deep Security Manager\.keystore"
```
- f. In the `C:\Program Files\Trend Micro\Deep Security Manager\configuration.properties` file, set the keystore password for the `keystorePass` value, and then save the file.
- g. Restart Deep Security Manager.
- h. Verify that the browser can validate the certificate.

Update the load balancer's certificate

Usually, your browser should warn you with a certificate validation error whenever you try to connect to a server with a self-signed certificate. This is because with any *self*-signed certificate, the browser cannot automatically validate the certificate's signature with a trusted *third party* certificate authority (CA), and therefore the browser doesn't know if the certificate was sent by an attacker or not. When installed, Deep Security Manager is initially configured to use a self-signed certificate for HTTPS connections (SSL or TLS), so you must manually verify that the server certificate fingerprint used to secure the connection belongs to your Deep Security server. This is normal until you replace the self-signed certificate with a CA-signed certificate.

The same error will occur if you have an AWS Elastic Load Balancer (ELB) or other load balancer, and it presents a self-signed certificate to the browser.



Your connection is not private

Attackers might be trying to steal your information from **deepsecurity.example.com** (for example, passwords, messages, or credit cards). NET::ERR_CERT_AUTHORITY_INVALID

[Automatically report](#) details of possible security incidents to Google. [Privacy policy](#)

HIDE ADVANCED Back to safety

This server could not prove that it is **deepsecurity.example.com**; its security certificate is not trusted by your computer's operating system. This may be caused by a misconfiguration or an attacker intercepting your connection. [Learn more.](#)

Proceed to [deepsecurity.example.com](#) (unsafe)



You can still access Deep Security Manager if you ignore the warning and proceed (method varies by browser). However, this error will occur again each time you connect, unless you either:

- add the certificate to your computer's store of trusted certificates (not recommended) or
 - replace the load balancer's certificate with one signed by a trusted CA (strongly recommended)
1. With a CA that is trusted by all HTTPS clients, register the fully qualified domain name (*not IP address*) that administrators, relays, and agents will use to connect to Deep Security

Manager.

Specify the sub-domain (for example, deepsecurity.example.com) that will uniquely identify Deep Security Manager. For nodes behind an SSL terminator load balancer, this certificate will be presented to browsers and other HTTPS clients by the load balancer, not by each Deep Security Manager node.

When the CA signs the certificate, download both the certificate (with public key) and the private key.

Warning: Store and transmit the private key securely. If file permissions or unencrypted connections allow a third party to access your private key, then all connections secured by that certificate and key are compromised. You must revoke that certificate, remove the key, and get a new certificate and key.

2. [Add the certificate to your certificate store](#) (optional if your computer trusts the CA that signed the certificate).
3. [Update the DNS settings of the load balancer to use the new domain name](#).
4. [Replace the SSL certificate of the load balancer](#).

Encrypt communication between the Deep Security Manager and the database

If the communication channel between the Deep Security Manager and the database is not secure, you may wish to encrypt the communications between them. In the current design, Deep Security Manager first attempts to build an encrypted connection with the database server. If it fails, Deep Security Manager uses an unencrypted connection with the database server instead.

The related mechanisms are built into the database library that Deep Security Manager is based on, therefore the server certificate doesn't need to be imported and the configuration file doesn't need to be updated. You should consult with the database vendor and their supporting documentation to determine if there will be any significant performance impact when enabling encrypted sessions.

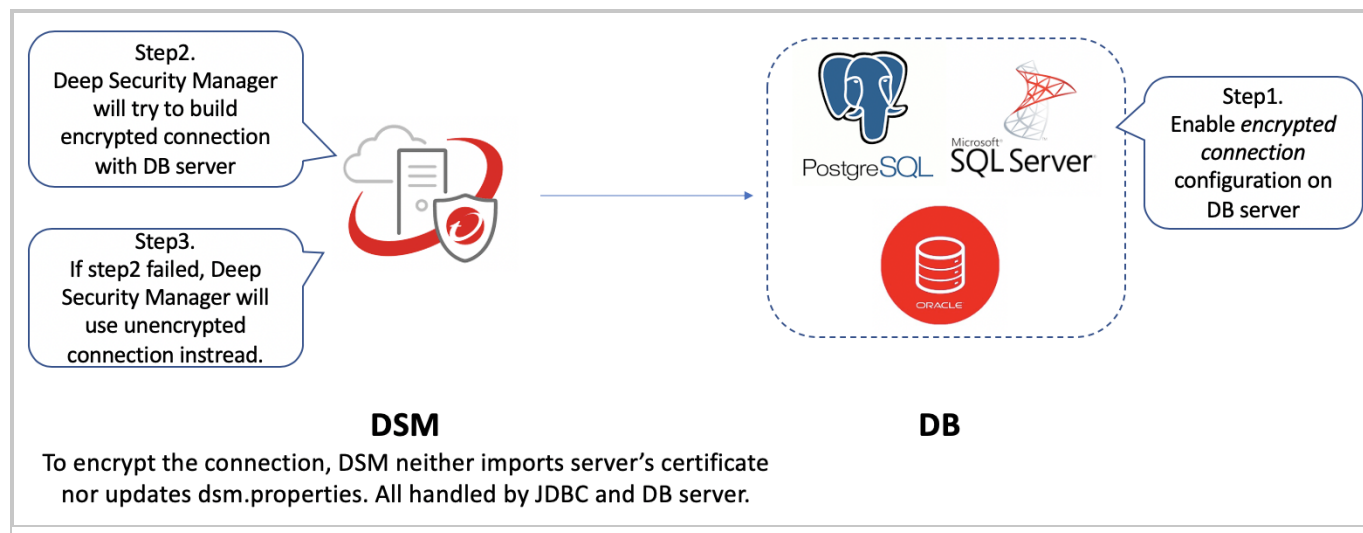

The instructions vary depending on the database you are using:

- ["Microsoft SQL Server database" below](#)
- ["Oracle database" on the next page](#)
- ["PostgreSQL" on page 1585](#)

Note: If you are running the Deep Security Manager in multi-node mode, these changes must be made on each node.

This section also provides information on ["Running an agent on the database server" on page 1585](#) how to ["Disable encryption between the manager and database" on page 1585](#), and how to ["Upgrade from an old Deep Security Manager version" on page 1587](#).

Encrypt communication between the manager and database

Microsoft SQL Server database

If you have **not** already installed Deep Security Manager 20:

1. Follow the instructions in [Enable encrypted connections to the Database Engine](#) on the Microsoft MSDN site and enable encrypted connection options on Microsoft SQL Server.
2. ["Install Deep Security Manager" on page 442](#).

By default, the communication between Deep Security Manager 20 and Microsoft SQL Server is encrypted.

If you have **already** installed Deep Security Manager 20 and you haven't enabled encryption options on your Microsoft SQL Server:

1. Stop Deep Security Manager 20.
2. Follow the instructions in [Enable encrypted connections to the Database Engine](#) on the Microsoft MSDN site and enable encrypted connection options on Microsoft SQL Server.
3. ["Restart the Deep Security Manager" on page 1694.](#)

By default, the communication between Deep Security Manager 20 and Microsoft SQL Server is encrypted.

Note: You can use SQL Server Manager Studio to connect your Microsoft SQL Server. Use the command `select client_net_address,connect_time,net_transport,protocol_type,encrypt_option from sys.dm_exec_connections` to see if your Deep Security Manager encrypted connection is working or not.

Oracle database

If you have **not** already installed Deep Security Manager 20:

1. Follow the instructions [How To Configure Data Encryption and Integrity](#) on the Oracle Help Center, and enable encrypted connection options on Oracle Database Server side.
2. ["Install Deep Security Manager" on page 442.](#)

By default, the communication between Deep Security Manager 20 and Oracle Database Server is encrypted.

If you have **already** installed Deep Security Manager 20 and you haven't enabled encryption options on your Oracle Database Server:

1. Stop Deep Security Manager 20.
2. Follow the instructions [How To Configure Data Encryption and Integrity](#) on the Oracle Help Center, and enable encrypted connection options on Oracle Database Server side.
3. ["Restart the Deep Security Manager" on page 1694.](#)

By default, the communication between Deep Security Manager 20 and Oracle Database Server is encrypted.

Note: Follow the Oracle blog article [Verifying the use of Native Encryption and Integrity](#) to see if the encrypted connection is working or not.

PostgreSQL

If you have not already installed Deep Security Manager 20:

1. Turn on SSL in PostgreSQL. For on-premises PostgreSQL database, see Secure [TCP/IP Connections with SSL](#) for more information. For an Amazon RDS for PostgreSQL, see [Using SSL with a PostgreSQL DB Instance](#) for more information.
2. ["Install Deep Security Manager" on page 442.](#)

By default, the communication between Deep Security Manager 20 and PostgreSQL Database Server is encrypted.

If you have already installed Deep Security Manager 20 and you haven't enabled encryption options on your PostgreSQL Database Server:

1. Stop Deep Security Manager 20.
2. Turn on SSL in PostgreSQL. For on-premises PostgreSQL database, see Secure [TCP/IP Connections with SSL](#) for more information. For an Amazon RDS for PostgreSQL, see [Using SSL with a PostgreSQL DB Instance](#) for more information.
3. ["Restart the Deep Security Manager" on page 1694.](#)

By default, the communication between Deep Security Manager 20 and PostgreSQL Database Server is encrypted.

Note: To check that the manager is connected using TLS, use the following query and check the SSL column: `select a.client_addr, a.application_name, a.username, s.* from pg_stat_ssl s join pg_stat_activity a using (pid) where a.datname='<Deep Security database name>';`

Running an agent on the database server

Encryption should be enabled if you are using an agent to protect the database. When you perform a security update, the Deep Security Manager stores new Intrusion Prevention rules in the database. The rule names themselves will almost certainly generate false positives as they get parsed by the agent if the data is not encrypted.

Disable encryption between the manager and database

In rare cases, you may need to disable encryption between Deep Security Manager and the database. For example, if you're using an older version of SQL Server, you may need to disable

encryption to avoid connection errors. For details, see [Error: The installer could not establish a secure connection to the database server](#).

Follow the instructions for your database type to disable encryption.

Microsoft SQL Server

1. Stop the Deep Security Manager service.
2. In the SQL Server, disable the "Force Encryption" option that was enabled in [Enable encrypted connections to the Database Engine](#).
3. (Optional) If your Deep Security Manager 20 was upgraded from Deep Security Manager 12.5 or older, remove all encryption related configurations in `dsm.properties`:

```
database.SqlServer.encrypt=true
```

```
database.SqlServer.trustServerCertificate=true
```

Note: If you upgraded from Deep Security 10.1 or a previous version, and your connection to the database uses named pipes as the transport, remove the following line instead: `database.SqlServer.ssl=require`

4. Restart Microsoft SQL Server if necessary.
5. Start Deep Security Manager.

Oracle Database

1. Stop the Deep Security Manager service.
2. Follow [How To Configure Data Encryption and Integrity](#) to disable the connection encryption in the Oracle server.
3. (Optional) If your Deep Security Manager 20 was upgraded from Deep Security Manager 12.5 or older, remove all encryption related configurations in `dsm.properties`:

```
database.Oracle.oracle.net.encrypted_types_client=(AES256)
```

```
database.Oracle.oracle.net.encrypted_client=REQUIRED
```

```
database.Oracle.oracle.net.crypto_checksum_types_client=(SHA1)
```

```
database.Oracle.oracle.net.crypto_checksum_client=REQUIRED
```

4. Restart the Oracle listener.
5. Start the Deep Security Manager service.

PostgreSQL

1. Stop the Deep Security Manager service.
2. Follow Secure TCP/IP Connections with SSL to remove `ssl=on` in `postgresql.conf` and disable the connection encryption in the PostgreSQL database.
3. (Optional) If your Deep Security Manager 20 was upgraded from Deep Security Manager 12.5 or older, remove all encryption related configurations in `dsm.properties`:

```
database.PostgreSQL.connectionParameters=ssl=true
```

4. Restart the PostgreSQL service.
5. Start the Deep Security Manager service.

Upgrade from an old Deep Security Manager version

If you're currently using Deep Security Manager 12.5 or older and meet the following criteria:

- Encrypted connection is enabled.
- Uses PostgreSQL database server.

Please follow the instructions below before upgrading.

If either of the above criteria is not satisfied, you can ignore the following section and upgrade straight to Deep Security Manager 20.0.

Upgrade Deep Security Manager

Since PostgreSQL JDBC driver has different behaviors in different versions, you need to complete the following steps before upgrading.

1. Export the certificate from your PostgreSQL database server. (This should already be completed because the old Deep Security Manager requires the certificate to enable connection encryption).
2. Rename the certificate file as `root.crt`.
3. Put it in the predefined Deep Security Manager 20 path:

In Linux, put `root.crt` in `~/.postgresql/`

In Windows, put `root.crt` in `c:\Users\{USERNAME}\AppData\Roaming\postgresql\`.

4. Run the upgrade flow. Deep Security Manager 20 will continue to use an encrypted connection with PostgreSQL server after upgrade.

Change the Deep Security Manager database password

Your organization's security policies may require that you periodically change the password that Deep Security Manager uses to access the database.

- ["Change your Microsoft SQL Server password" below](#)
- ["Change your Oracle password" on the next page](#)
- ["Change your PostgreSQL password" on the next page](#)

Change your Microsoft SQL Server password

1. On Windows, stop the Trend Micro Deep Security Manager service on each of your Deep Security Manager instances.

On Linux, the command to stop the service is:

```
# service dsm_s stop
```

2. Use SQL Server Management Studio to change the SQL user password.
3. On each Deep Security Manager instance, modify the

`/opt/dsm/webclient/webapps/ROOT/WEB-INF/dsm.properties` file to specify the new password. When you open this file, you will see an obfuscated value for the password, similar to this:

```
database.SqlServer.password=$1$4ec04f9550e0bf378fa6b1bc9698d0bbc59ac010  
bfef7ea1e6e47f30394800b1a9554fe206a3ee9ba5f774d205ba03bb86c91c0664c7f05  
f8c467e03e0d8ebbe
```

Overwrite that value with your new password (the new password will be obfuscated when the service restarts):

```
Database.SqlServer.password=NEW PASSWORD GOES HERE
```

4. On Windows, start the Trend Micro Deep Security Manager service on each of your Deep Security Manager instances.

On Linux, the command to start the service is:

```
# service dsm_s start
```

Change your Oracle password

1. On Windows, stop the Trend Micro Deep Security Manager service on each of your Deep Security Manager instances.

On Linux, the command to stop the service is:

```
# service dsm_s stop
```

2. Use your Oracle tools to change the password.
3. On each Deep Security Manager instance, modify the `/opt/dsm/webclient/webapps/ROOT/WEB-INF/dsm.properties` file to specify the new password. When you open this file, you will see an obfuscated value for the password, similar to this:

```
database.Oracle.password=$1$4ec04f9550e0bf378fa6b1bc9698d0bbc59ac010bfe  
f7ea1e6e47f30394800b1a9554fe206a3ee9ba5f774d205ba03bb86c91c0664c7f05f8c  
467e03e0d8ebbe
```

Overwrite that value with your new password (the new password will be obfuscated when the service restarts):

```
Database.Oracle.password=NEW PASSWORD GOES HERE
```

4. On Windows, start the Trend Micro Deep Security Manager service on each of your Deep Security Manager instances.

On Linux, the command to start the service is:

```
# service dsm_s start
```

Change your PostgreSQL password

1. On Windows, stop the Trend Micro Deep Security Manager service on each of your Deep Security Manager instances.

On Linux, the command to stop the service is:

```
# service dsm_s stop
```

2. Follow instructions from your PostgreSQL documentation to change the password.
3. On each Deep Security Manager instance, modify the `/opt/dsm/webclient/webapps/ROOT/WEB-INF/dsm.properties` file to specify the new password. When you open this file, you will see an obfuscated value for the

password, similar to this:

```
database.PostgreSQL.password=$1$4ec04f9550e0bf378fa6b1bc9698d0bbc59ac01  
0bfef7ea1e6e47f30394800b1a9554fe206a3ee9ba5f774d205ba03bb86c91c0664c7f0  
5f8c467e03e0d8ebbe
```

Overwrite that value with your new password (the new password will be obfuscated when the service restarts):

```
Database.PostgreSQL.password=NEW PASSWORD GOES HERE
```

4. On Windows, start the Trend Micro Deep Security Manager service on each of your Deep Security Manager instances.

On Linux, the command to start the service is:

```
# service dsm_s start
```

Configure HTTP security headers

Security headers are directives used by web applications to configure security defenses in web browsers. Based on these directives, browsers can make it harder to exploit client-side vulnerabilities such as Cross-Site Scripting or Clickjacking. Headers can also be used to configure the browser to only allow valid TLS communication and enforce valid certificates, or even enforce using a specific server certificate.

The sections below detail the various security headers and support for them in Deep Security:

- ["Customizable security headers" below](#)
- ["Enforced security headers" on page 1593](#)
- ["Unsupported security headers" on page 1594](#)

Customizable security headers

The following headers can be enabled and configured based on specific environment requirements:

- ["HTTP Strict Transport Security \(HSTS\)" on the next page](#)
- ["Content Security Policy \(CSP\)" on the next page](#)
- ["HTTP Public Key Pinning \(HPKP\)" on page 1592](#)

Note: As the primary tenant, you can ["Enable customizable security headers"](#) on the next page in the Deep Security Manager or ["Reset your configuration"](#) on page 1593.

HTTP Strict Transport Security (HSTS)

HTTP Strict Transport Security is a header that configures the web browser to always use a valid secure connection with the web application. If the server TLS certificate suddenly becomes expired or untrusted, the browser will no longer connect to the web application. Also, if the user attempts to access the web application using an `http://` url, the browser will automatically change it to `https://`. These countermeasures help prevent Man-in-the-middle attacks as well as other attacks such as Session Hijacking.

On install, the Deep Security Manager console has a self-signed (untrusted) certificate and HSTS is turned off. This is because each organization must configure the Deep Security web application with a specific certificate that matches the manager hostname. This can also be achieved by configuring a Load Balancer with TLS termination such as AWS ELB/ALB.

Once a valid TLS configuration is in place, the HTTP Strict Transport Security Header can be enabled from **Administration > System Settings > Security**.

For instructions on enabling HTTP Strict Transport Security (HSTS), see ["Enable customizable security headers" on the next page](#).

Content Security Policy (CSP)

Content Security Policy includes a comprehensive set of directives that help prevent client-side attacks, such as Cross-Site Scripting and Clickjacking, by restricting the type of content the browser is allowed to include or execute.

Note: Enabling CSP can have adverse effects. For example, embedded scripts might stop working or certain types of images required by third-party components such as jQuery might not load.

When you enable CSP, it is always a good idea to run it in **Report only** first and observe if any violations are reported to the provided URL for expected application functionality.

The Deep Security CSP can be configured under **Administration > System Settings > Security**.

Deep Security works best with the following settings:

```
object-src 'self'
```

```
default-src 'self'
```

```
script-src 'self' 'unsafe-eval' 'unsafe-inline'
```

```
frame-src 'self'
```

```
frame-ancestors 'self'
```

```
style-src 'self' 'unsafe-inline' blob:
```

```
form-action 'self'
```

```
img-src 'self' data:
```

```
report-uri https://your_report_uri.org/DS_CSP_Violation
```

Note: By default, the **Report only** check box is selected. Once you confirm that the CSP does not break the expected application functionality, you can deselect **Report only** to enforce the policy.

Warning: Currently, **script-src** does not support 'nonce' or 'hash-algorithm'. If you have concerns about cross-site scripting (XSS), [enable the Intrusion Prevention rule 1000552 - Generic Cross Site Scripting \(XSS\) Prevention](#).

For instructions on enabling Content Security Policy (CSP), see "[Enable customizable security headers](#)" below.

HTTP Public Key Pinning (HPKP)

The HPKP header forces browsers to only trust a specific certificate or certificate authority for secure communications. This prevents attacks that leverage a trusted certificate authority which has been compromised or maliciously installed on the client.

Note: Enabling HPKP can leave browsers unable to connect if a certificate is changed without its header also being changed.

For instructions on enabling HTTP Public Key Pinning (HPKP), see "[Enable customizable security headers](#)" below.

Enable customizable security headers

Note: In multi-tenant mode, security header settings are only available to the primary tenant.

1. Go to **Administration > System Settings > Security**.
2. Enter your HTTP Strict Transport Security (HSTS), Content Security Policy (CSP), or HTTP Public Key Pinning (HPKP) directive(s) in the corresponding field(s).

Note: Before you enable settings, you can test them by selecting the **Report Only** option and verifying that the policy violation reports are correct.

Tip: You can enter individual policy directives on separate lines.

3. Click **Save** at the bottom of the page.

Reset your configuration

If you experience trouble while configuring your directive and cannot correct it in the Deep Security Manager, SSH into the manager and run the corresponding commands to reset your configuration:

HTTP Strict Transport Security

```
dsm_c -action changesetting -name  
settings.configuration.enableHttpStrictTransportSecurity -value ""
```

```
dsm_c -action changesetting -name  
settings.configuration.enableHttpStrictTransportSecurity -value "false"
```

Content Security Policy

```
dsm_c -action changesetting -name  
settings.configuration.contentSecurityPolicy -value ""
```

```
dsm_c -action changesetting -name  
settings.configuration.contentSecurityPolicyReportOnly -value "true"
```

Public Key Pinning Policy

```
dsm_c -action changesetting -name settings.configuration.publicKeyPinPolicy  
-value ""
```

```
dsm_c -action changesetting -name  
settings.configuration.publicKeyPinPolicyReportOnly -value "true"
```

Enforced security headers

The following headers are enforced by default and cannot be changed:

- ["Cache-Control and Pragma" below](#)
- ["X-XSS-Protection" below](#)
- ["X-Frame-Options" below](#)

Cache-Control and Pragma

These headers configure how the browser caches content. Caching sensitive content from an authenticated application can be a security vulnerability if the content is cached on a machine that is used by multiple users or if an attacker gains access to an unlocked machine after the user has logged out of the application. For this reason, Deep Security disables caching on all content that is not static by enforcing the `no-cache` and `no-store` values.

X-XSS-Protection

This XSS-Protection header forces the browser's Cross-Site Scripting (XSS) heuristics to detect XSS attacks. Deep Security enforces this header in block mode by default. This means that if the browser detects a potential XSS attack it will stop the page from loading altogether—a safer approach than the alternative of trying to sanitize the page by replacing potentially malicious elements.

Note: XSS-Protection does not work for all types of attacks and not all browsers have an XSS filter.

X-Frame-Options

This header helps to prevent Clickjacking attacks. The Deep Security Manager enforces the `SAMEORIGIN` value for this header, only allowing it to be embedded in web applications that are hosted on the same domain.

Note: This header has the same effect as the frame-ancestors CSP directive. The frame-ancestors directive will override the value of the X-Frame-Options header.

Unsupported security headers

The following header type is unsupported.

X-Content-Type-Options

This header with the `nosniff` value helps protect against mime type sniffing. Mime type sniffing attacks are only effective in specific scenarios where they cause the browser to interpret text or binary content as HTML. For example, if a user uploads an avatar file named `xss.html` and the web application does not set a Content-type header when serving the image, the browser will try to determine the content type and will likely treat `xss.html` as an HTML file. The attacker can then direct users to `xss.html` and conduct a Cross-Site Scripting attack.

Deep Security does not currently support enabling this header as it has been observed to cause adverse effects on redirects, however the relevant attack scenarios are not likely to impact the manager web application and its usual functionality.

Upgrade the Deep Security cryptographic algorithm

Deep Security 9.6 SP1 and earlier use RSA-1024 and SHA-1 to secure communication between the Deep Security Manager and Deep Security Agents. By default, Deep Security 10.0 or later uses RSA-2048 and SHA-256, which are more secure algorithms.

A new installation of Deep Security 10.0 or later will use RSA-2048 and SHA-256 but if you upgrade from an earlier version to Deep Security 10.0 or later, it will continue to use the earlier cryptographic algorithms unless you upgrade them separately.

This article describes how to upgrade the algorithms after upgrading to Deep Security 10.0 or later. After you change the settings as described in this article, the Deep Security Manager generates new certificates for itself and all managed agents. When agents connect to the Deep Security Manager again, the manager sends new certificates to the agents.

Upgrade the algorithm on Windows

1. Use the Services window of the Microsoft Management Console to stop the "Trend Micro Deep Security Manager" service.
2. In the Windows command line, go to the Deep Security Manager's working folder, for example, `C:\Program Files\Trend Micro\Deep Security Manager`.
3. Use the `dsm_c` command with parameters to change to the new settings. For example:

```
dsm_c -action changesetting -name  
settings.security.defaultSignatureAlg -value "SHA256withRSA"
```

```
dsm_c -action changesetting -name settings.security.defaultKeyLength -  
value "2048"
```

```
dsm_c -action changesetting -name  
settings.security.forceCertificateUpdate -value "true"
```

4. If you don't see any errors, restart the Trend Micro Deep Security Manager service.

Upgrade the algorithm on Linux

1. At the command line, go to the directory where the Deep Security Manager service is running and stop the service by entering:

```
service dsm_s stop
```

2. In the Linux command line, go to the Deep Security Manager's working folder, for example, `/opt/dsm`.
3. Use the `dsm_c` command with parameters to change to the new settings. For example:

```
./dsm_c -action changesetting -name  
settings.security.defaultSignatureAlg -value "SHA256withRSA"
```

```
./dsm_c -action changesetting -name settings.security.defaultKeyLength  
-value "2048"
```

```
./dsm_c -action changesetting -name  
settings.security.forceCertificateUpdate -value "true"
```

4. If you don't see any errors, restart the Trend Micro Deep Security Manager service.

Upgrade the algorithm in a multi-node environment

If you are running Deep Security Manager on multiple nodes, execute the `dsm_c` commands (described above) on one of the nodes, and then manually restart the "Trend Micro Deep Security Manager" service on each of the other nodes to make the changes take effect there.

Upgrade the algorithm in a multi-tenant environment

In Deep Security 10.0, the algorithm settings are independent for each tenant. You will need to update the settings for each tenant by appending the tenant name (using `-tenantname`) or tenant ID (using `-tenantid`) on the `dsm_c` command. For example, to change the settings for a tenant whose ID is 5:

```
dsm_c -action changesetting -name settings.security.defaultSignatureAlg -  
value "SHA256withRSA" -tenantid 5
```

```
dsm_c -action changesetting -name settings.security.defaultKeyLength -value "2048" -tenantid 5
```

```
dsm_c -action changesetting -name settings.security.forceCertificateUpdate -value "true" -tenantid 5
```

Enforce user password rules

You can specify password requirements for Deep Security Manager passwords, and other settings related to user authentication.

Specify password requirements

Note: For greater security, enforce stringent password requirements: minimum 8 characters, include both numbers and letters, use upper and lower case, include non-alphanumeric characters, and expire regularly.

Go to **Administration > System Settings > Security**. In the **User Security** section, you can change these settings:

- **Session idle timeout:** Specify the period of inactivity after which a user will be required to sign in again.
- **Maximum session duration:** Maximum length of time that a user can be signed into the Deep Security Manager before they'll be required to sign in again.
- **Number of incorrect sign-in attempts allowed (before lock out):** The number of times an individual user (i.e. with a specific username) can attempt to sign in with an incorrect password before they are locked out. Only a user with "Can Edit User Properties" rights can unlock a locked-out user (see "[Define roles for users](#)" on page 1488).

Note: If a user gets locked out for a particular reason (too many failed sign-in attempts, for example), and no user remains with the sufficient rights to unlock that account, please contact Trend Micro for assistance.

- **Number of concurrent sessions allowed per User:** Maximum number of simultaneous sessions allowed per user.

Note: A note about being signed in as two users at once: Remember that Firefox sets session cookies on a per-process basis, and not on a per-window basis. This means that

if for some reason you want to be signed in as two users at the same time, you will either have to use two different browsers (if one of them is Firefox), or sign in from two separate computers.

- **Action when concurrent session limit is exceeded:** Specifies what happens when a user reaches the maximum number of concurrent sessions.
- **User password expires:** Number of days that passwords are valid. You can also set passwords to never expire.
- **User password minimum length:** The minimum number of characters required in a password.
- **User password requires both letters and numbers:** Letters (a-z, A-Z) as well as numbers (0-9) must be used as part of the password.
- **User password requires both upper and lower case characters:** Upper and lower case characters must be used.
- **User password requires non-alphanumeric characters:** Passwords must include non-alphanumeric characters.
- **Send email when a user's password is about the expire:** Before a user's password expires, they will receive an email message. To use this feature, you must ["Configure SMTP settings for email notifications" on page 1269](#).

Use another identity provider for sign-on

You can also configure Deep Security to use SAML single sign-on. For details, see ["Configure SAML single sign-on" on page 1509](#).

Add a message to the Deep Security Manager Sign In page

On the **Administration > System Settings > Security** page, use **Sign-In Page Message** to enter text that will be displayed on the Deep Security Manager's sign in page.

Present users with terms and conditions

You can configure Deep Security Manager so that users must agree to terms and conditions before they can sign in to the Deep Security Manager.

To enable this feature, select **User must agree to the terms and conditions** on the **Administration > System Settings > Security** page. In the two text boxes, enter a title and the list of terms and conditions that will be displayed when a user clicks the **Terms and Conditions** link on the Sign In page.

Other Security settings

The **Administration > System Settings > Security** page also enables you to:

- ["Manage trusted certificates" on page 1603](#)
- ["Configure HTTP security headers" on page 1590](#)

Set up multi-factor authentication

The Deep Security Manager allows you the option to use multi-factor authentication (MFA). MFA is a method of access control requiring more than a user name and password that is recommended as a best practice.

In this article:

- ["Enable multi-factor authentication" below](#)
- ["Disable multi-factor authentication" on page 1602](#)
- ["Supported multi-factor authentication \(MFA\) applications" on page 1602](#)
- ["Troubleshooting MFA" on page 1603](#)

Enable multi-factor authentication

1. In Deep Security Manager, select **User Properties** from the menu under your user name in the upper-right corner.
2. On the **General** tab, click the **Enable MFA** button. This will open the **Enable Multi-Factor Authentication** wizard to guide you through the rest of the process.
3. The first screen of the wizard will remind you to install a compatible virtual MFA application, such as Google Authenticator. For more information, see ["Supported multi-factor authentication \(MFA\) applications" on page 1602](#) at the bottom of this article.
4. If your device supports scanning QR codes, you can use your camera to configure your MFA application and click **Next**.

Otherwise, you can choose **My device does not support scanning QR codes. Show secret**

key for manual time-based configuration.

5. Enter the **Authentication Code** (without the space), for example: 228045.

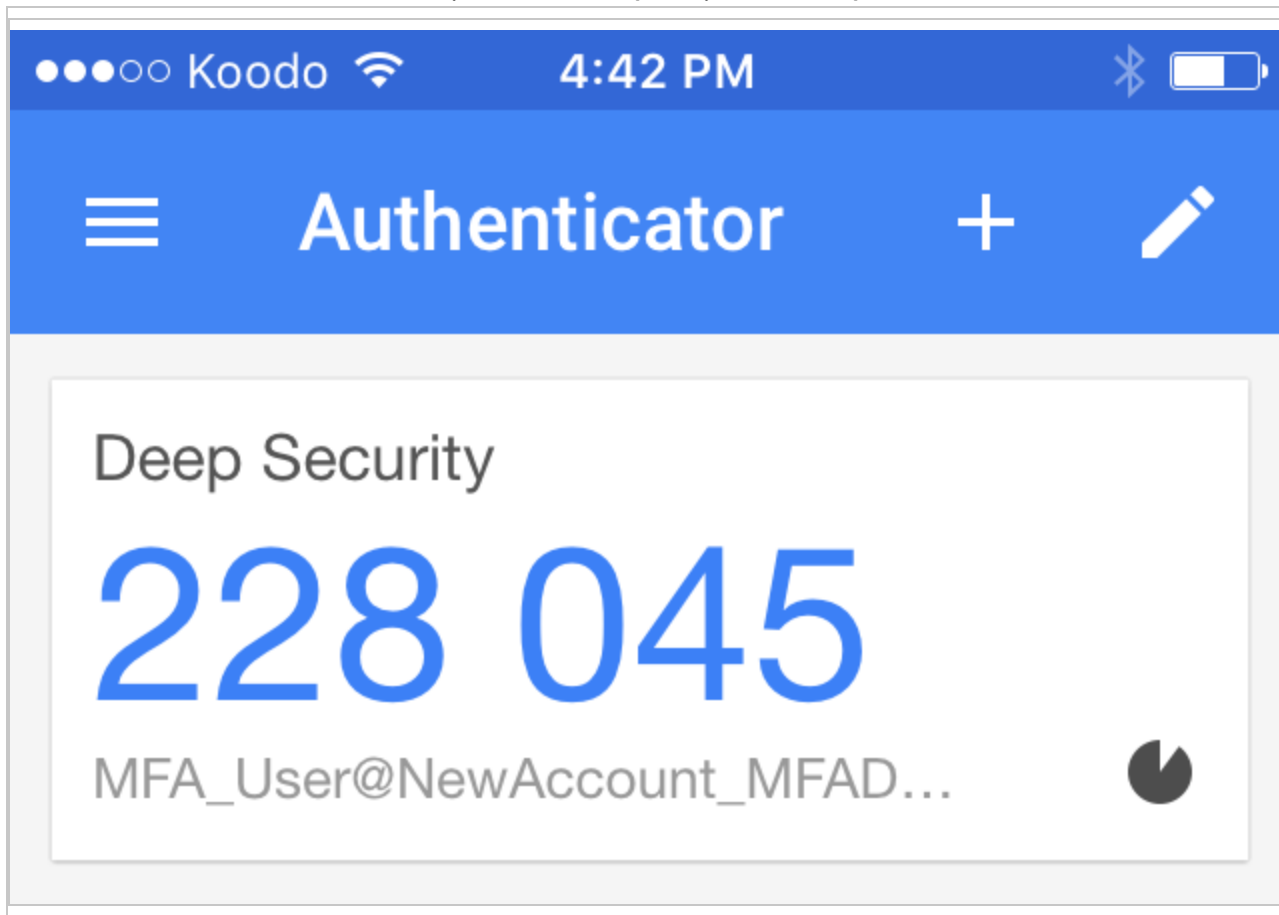

- 6. If the authorization code is correct, MFA will be enabled for your account and you will be required to enter a new MFA code each time you sign in.

The screenshot shows the 'Sign In' interface for Trend Micro Deep Security. At the top, there is a dark navigation bar with the Trend Micro logo on the left, the text 'Deep Security' in the center, and a 'Support' link on the right. Below the navigation bar, the page title 'Sign In' is centered. The form consists of three input fields: a 'Username' field containing 'MasterAdmin', a 'Password' field (masked with dots) with a key icon on the right, and an 'Authentication Code' field containing '264387'. A checkbox labeled 'Use Multi-Factor Authentication' is checked. A 'Sign In' button is positioned at the bottom right of the form area.

Disable multi-factor authentication

1. In the Deep Security Manager, select **User Properties** from the menu under your user name in the upper-right corner.
2. On the **General** tab, click the **Disable MFA** button.
3. Click **OK** on the confirmation screen to disable MFA.

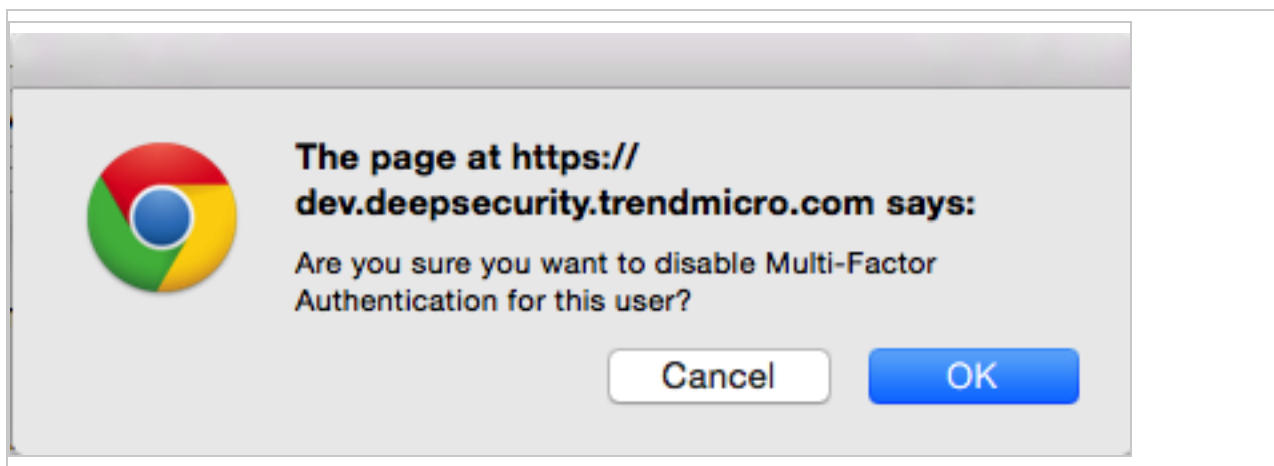

4. Your user properties screen displays with a note to indicate the changes to MFA. Click **OK** to close the screen.

Supported multi-factor authentication (MFA) applications

The following smartphones and applications are actively supported for MFA. However, any application implementing an RFC 6238 compliant Time-base One-time Password Algorithm should work.

Smartphone	MFA App
Android	Google Authenticator , Duo
iPhone	Google Authenticator , Duo
Blackberry	Google Authenticator

Troubleshooting MFA

What if my MFA is enabled but not working?

The most common source of MFA login issues is caused by the time on your Deep Security Manager being out of sync with your device.

Follow the instructions below for your chosen operating system to make sure the time is properly synced:

If your Deep Security Manager is Linux:

Check that NTP is working correctly by entering `ntpstat` in the command line. To view the current system time and date, enter `date`.

If your Deep Security Manager is Windows:

Check that the Windows Time Service is working correctly. To view the current system time and date, enter `time` and `date` in the command line.

What if my MFA device is lost or stops working?

If your MFA device is lost, destroyed, or stops working, you'll need to have MFA disabled for your account in order to be able to sign in.

1. Get in touch with the person who provided you with your sign in credentials and ask them to follow the instructions in ["Disable multi-factor authentication" on the previous page](#). (You'll then be able to sign in with just your user name and password.)
2. After you've signed in, change your password.
3. Follow the instructions for ["Enable multi-factor authentication" on page 1599](#).

Manage trusted certificates

Trusted certificates are used for code signing and SSL connections to external services such as a Microsoft Active Directory and VMware vCenter. They are also used to exclude files from Anti-Malware scanning.

Import trusted certificates

Note: If you are importing a trusted certificate to establish trust with an Amazon Web Services region, you must use the `dsm_c` command-line tool.

To import trusted certificates using the Deep Security Manager:

1. In the Deep Security Manager, go to **Administration > System Settings > Security**.
2. Under **Trusted Certificates**, click **View Certificate List** to view a list of all security certificates accepted by Deep Security Manager.
3. Click **Import From File** to start the Import Certificate wizard.

To import a trusted certificate using dsm_c:

1. On the Deep Security Manager server, run the following command:

```
dsm_c -action addcert -purpose PURPOSE -cert CERTFILE
```

where the parameters are:

Parameter	Description	Sample value
PURPOSE	What type of connections the certificate will be used for. This value must be selected from one of the sample values listed on the right.	AWS - Amazon Web Services
		DSA - code signing
		EXCEPTION - scan exclusion
		SSL - SSL connections
CERTFILE	The (user-defined) name of the file containing the certificate you want to import.	/path/to/cacert.pem

Note: If you are running the Deep Security Manager in a Linux environment, you will need to run the `dsm_c` command as the root user.

View trusted certificates

Note: To view trusted certificates for Amazon Web Services connections, you must use the `dsm_c` command-line tool.

To view trusted certificates using the Deep Security Manager:

1. In the Deep Security Manager, go to **Administration > System Settings > Security**.
2. Under **Trusted Certificates**, click **View Certificate List**.

To view trusted certificates using dsm_c:

1. On the Deep Security Manager server, run the following command:

```
dsm_c -action listcerts [-purpose PURPOSE]
```

The `-purpose PURPOSE` parameter is optional and can be omitted to see a list of all certificates. If you specify a value for `PURPOSE`, then only the certificates used for that purpose will be shown.

Parameter	Description	Sample value
PURPOSE	What type of connections the certificate will be used for.	AWS - Amazon Web Services
		DSA - code signing
		EXCEPTION - scan exclusion
		SSL - SSL connections

Note: If you are running the Deep Security Manager in a Linux environment, you will need to run the `dsm_c` command as the root user.

Remove trusted certificates

Note: To remove trusted certificates for Amazon Web Services connections, you must use the `dsm_c` command-line tool.

To remove a trusted certificate using the Deep Security Manager:

1. In the Deep Security Manager, go to **Administration > System Settings > Security**.
2. Under **Trusted Certificates**, click **View Certificate List**.
3. Select the certificate you want to remove and click **Delete**.

To remove a trusted certificate using dsm_c:

1. Log in to Deep Security Manager .
2. Run the following command:

```
dsm_c -action listcerts [-purpose PURPOSE]
```

The `-purpose PURPOSE` parameter is optional and can be omitted to see a list of all

certificates. If you specify a value for `PURPOSE`, then only the certificates used for that purpose will be shown.

Parameter	Description	Sample value
PURPOSE	What type of connections the certificate will be used for.	AWS - Amazon Web Services
		DSA - code signing
		EXCEPTION - scan exclusion
		SSL - SSL connections

3. Find the `ID` value for the certificate you want to remove in the list.

4. Run the following command:

```
dsm_c -action removecert -id ID
```

The `ID` parameter value is required.

Parameter	Description	Sample value
ID	The ID value assigned by Deep Security Manager for the certificate you want to delete.	3

Note: If you are running the Deep Security Manager in a Linux environment, you will need to run the `dsm_c` commands as the root user.

SSL implementation and credential provisioning

The Deep Security Agent may initiate communication to Deep Security Manager or it may be contacted by the manager if the computer object is set to operate in bi-directional mode. Deep Security Manager treats all connections to agents and appliances in a similar way. If the agent has not been activated, a limited set of interactions are possible. If the agent has been activated (either by an administrator or via the agent-initiated activation feature), the full set of interactions are enabled. The Deep Security Manager acts as an HTTP client in all cases, regardless of whether it was the client when forming the TCP connection. Agents and appliances cannot ask for data or initiate operations themselves. The manager requests information such as events and status, invokes operations, or pushes configuration to the agent. This security domain is highly

controlled to ensure that agents and appliances have no access to Deep Security Manager or the computer that it is running on.

Both agent and manager use two different security contexts to establish the secure channel for HTTP requests:

1. Before activation, the agent accepts the bootstrap certificate to form the SSL or TLS channel.
2. After authentication, mutual authentication is required to initiate the connection. For mutual authentication, the manager's certificate is sent to the agent and the agent's certificate is sent to the manager. The agent validates that the certificates come from the same certificate authority (which is the Deep Security Manager) before privileged access is granted.

Once the secure channel is established, the agent acts as the server for the HTTP communication. It has limited access to the manager and can only respond to requests. The secure channel provides authentication, confidentiality through encryption, and integrity. The use of mutual authentication protects against man-in-the-middle (MiTM) attacks where the SSL communication channel is proxied through a malicious third party. Within the stream, the inner content uses GZIP and the configuration is further encrypted using PKCS #7.

If I have disabled the connection to the Smart Protection Network, is any other information sent to Trend Micro?

When Smart Protection Network is disabled, the Deep Security Agents will not send any threat intelligence information to Trend Micro.

Upgrade Deep Security

About upgrades

Types of Deep Security updates from Trend Micro include:

- **Software upgrades:** New software such as the Deep Security [Manager](#), [Virtual Appliance](#), [Agent](#) and [Relay](#).
- **Security updates:** Rules and malware patterns that Deep Security Agent and Virtual

Appliance software uses to identify potential threats. Types of security updates include:

- **Pattern updates:** Used by Anti-Malware.
- **Rule updates:** Used by:
 - Firewall
 - Intrusion Prevention
 - Integrity Monitoring
 - Log Inspection

Application Control rule updates are created locally, based on your computers' software. They are not from Trend Micro.

The Anti-Malware engine in agent and virtual appliance software can be updated independently to keep up with the newest threats. See "[Enable automatic Anti-Malware engine updates](#)" on [page 1615](#).

Trend Micro releases new rule updates every Tuesday, with additional updates as new threats are discovered. Information about the updates is available in the Trend Micro [Threat Encyclopedia](#).

How Deep Security Manager checks for software upgrades

Deep Security Manager periodically connects to Trend Micro Update servers to check for updates to software that you have [imported into the Deep Security Manager database](#), such as:

- Deep Security Agent
- Deep Security Virtual Appliance
- Deep Security Manager

This checks based on the local inventory, not the [Download Center](#). (There is a separate alert for new software on the Download Center.)

Note:

Deep Security only informs you of **minor** version updates-not major-of software.

For example, if you have Deep Security Agent **9.6.100**, and Trend Micro releases **9.6.200**, an alert tells you that software updates are available. However, if **10.0.nnn** (a major version

difference) is released and you do not have any 10.0 agents, the alert does *not* appear (even though 10.0 is later than 9.6.100).

An alert on the manager notifies you that software updates are available. On **Administration > Updates > Software**, the Trend Micro Download Center section also indicates whether there are updates available. Once you import (download) software into the Deep Security Manager database, you can upgrade the software in your deployment. See "[Upgrade Deep Security Agent](#)" on page 1625 and "[Upgrade the appliance](#)" on page 1637.

Tip: To see *all* software packages that are available for download (even if you have not imported it before), go to **Administration > Updates > Software > Download Center**.

To determine when the last check was performed, whether it was successful, or to manually initiate a check for updates, go to **Administration > Updates > Software** and view the "Deep Security" section. If you have configured a scheduled task to check for updates, the date and time of the next scheduled check is also listed here. See "[Schedule Deep Security to perform tasks](#)" on page 1766.

When imported, software is stored in the Deep Security Manager database. Imported software is periodically replicated to relays.

Best practices for upgrades

When deploying a new release of the Deep Security Agent or Deep Security Virtual Appliance:

- Deep Security Relays must be the same version or newer than all agents and appliances in your environment.
- Deep Security Relays should be the same version as your Deep Security Manager.
- When performing upgrades of Deep Security software, the order of upgrade is important. Upgrade your Deep Security Manager first, then all relays, then agents and appliances.

Note: Beginning with Deep Security 20, you cannot activate a Deep Security Agent with a Deep Security Manager that is older than the **Minimum DSM Version** for that agent release. You can find the Minimum DSM Version on the [Deep Security Software download page](#).

Tip: With Workload Security, the manager and relays provided with the service are always up to date. You can ignore the Minimum DSM Version and not think about relay versions unless you choose to deploy extra relays in your environment.

How Deep Security validates update integrity

Both software updates and security updates are digitally signed. In addition to automatic checks, if you want to manually validate the signatures or checksums, you can use external tools such as:

- sha256sum (Linux)
- Checksum Calculator (Windows)
- jarsigner (Java Development Kit (JDK); see ["Check digital signatures on software packages" on page 427](#))

Digital signatures

When security updates are viewed, used, or imported into the Deep Security Manager database (either [manually](#) or automatically, via [scheduled task](#)), the manager validates the signature. A correct digital signature indicates that the software is authentically from Trend Micro and hasn't been corrupted or tampered with. If the digital signature is invalid, the manager does not use the file. A warning is also recorded in log files such as `server0.log`:

```
WARNING: ThID:85|TID:0|TNAME:Primary|UID:1|UNAME:MasterAdmin|Verifying the signature failed.
```

```
com.thirdbrigade.manager.core.general.exceptions.FileNotSignedValidationException: "corrupted_rules.zip." has not been digitally signed by Trend Micro and cannot be imported.
```

If you manually import a security update package with an invalid digital signature, the manager also displays an error message.



Note: Old security updates that are not signed fail validation if they are used, even if you successfully imported them in a previous version of Deep Security Manager that did not enforce signatures. For better protection, use new security updates instead. However if you still require the old security updates, you can contact your support provider to request a file that is signed, and then [manually import the security update](#).

Deep Security Agent also validates the digital signature, compares checksums (sometimes called hashes or fingerprints) and uses other, non-disclosed integrity methods.

Checksums

Software checksums (also called hashes or fingerprints) are published on the [Download Center](#). To view the SHA-256 hash, click the + button next to the software's name.

Agent [Show All Versions](#)

Software	Release Type	Build	Release Date	File Size	Download
1  Deep Security Agent 10.0.0-2775 for amzn1-x86_64	Update: 10.0_U9	10.0.0-2775	2018-04-04	64 MB	
2 Filename: Agent-amzn1-10.0.0-2775-x86_64.zip SHA256: ae057659377494c3275a87ef49332e10ab86c2ad2daf6538d73f268d4dba993b MD5: 38467af6e4aa681b00az79cd1e02blab Release Notes					

Apply security updates

To remain effective at identifying new threats, your Deep Security Agents and Virtual Appliances need periodic [security updates](#).

Before your agents, virtual appliances, and relays can receive security updates, you must define how to distribute them (see ["Deploy additional relays"](#) on page 1415 and ["Configure the update source"](#) on page 1418). Then you can:

- ["Initiate security updates"](#) on the next page
- ["Check your security update status"](#) on the next page
- ["View details about pattern updates"](#) on the next page
- ["Revert, import, or view details about rule updates"](#) on page 1613
- ["Configure security updates"](#) on page 1614

Initiate security updates

Tip: Instead of manually checking for updates, configure Deep Security Manager to automatically check for security updates via a scheduled task. See "[Schedule Deep Security to perform tasks](#)" on page 1766.

You can manually initiate security updates at any time, regardless of scheduled tasks.

- To get security updates for *all* agents and virtual appliances, go to **Administration > Updates > Security** and click **Check For Updates and Download**.
- To get security updates on *one* agent or virtual appliance, go to **Computers**, select the agent or virtual appliance, then right-click and select **Actions > Download Security Update**.

Check your security update status

To view the status of your security updates, go to **Administration > Updates > Security**.

- **Trend Micro Update Server:** Indicates whether relays can connect to Trend Micro ActiveUpdate to check for the latest security updates.
- **Deep Security:** Indicates when the last successful check and download were performed, and when the next scheduled check will be performed. **All Relays are in sync** indicates that all relays are distributing the latest successfully downloaded pattern updates.

Tip: Out-of-sync status usually indicates that the relay cannot connect to Trend Micro Update Servers. Usually, this is not normal. You should fix network connectivity problems. In "air-gapped" deployments, however, network isolation is intentional; you must provide updates manually.

- **Computers:** Indicates whether any computers are out-of-date *compared to the pattern updates currently on the relays*. To tell all computers to get the latest pattern updates from their assigned relays, click **Send Patterns to Computers**.

View details about pattern updates

To view a list of the components in an Anti-Malware pattern update, go to **Administration > Updates > Security > Patterns**. This page is displayed only when Deep Security has an active

relay.

- **Component:** The type of update component.
- **For Use By:** The Deep Security product this component is intended for.
- **Platform:** The operating system for which the update is intended.
- **Current Version:** The version of the component currently being distributed by the Deep Security Relays.

Tip: To check which security update component version is being used on a protected computer, go to **Computers**, double-click the computer, and then select **Updates**.

- **Last Updated:** When the current security update was downloaded from Trend Micro.

Revert, import, or view details about rule updates

To view a list of the most recent Intrusion Prevention, Integrity Monitoring, and Log Inspection Rules that have been downloaded into the Deep Security Manager database, go to **Administration > Updates > Security > Rules**.

From there you can:

- **View details about a rule update:** Select a rule update and click **View**. Details include a list of the update's specific rules.

Tip: To check which rule update version a relay is distributing, go to **Computers**, double-click the relay, and then select **Security Updates**. If Anti-Malware is enabled for that computer, it also displays the computer's pattern version.

- **Roll back a rule update:** If a recent rule update has caused problems, you can revert to a previous rule version. Select the rule update that you want to revert to and then click **Rollback**. Deep Security Manager generates a preview change summary so that you can confirm results before finalizing.

Note: All policies affected by the reverted rules will be immediately updated on *all computers using those policies*.

- **Reapply the current rule set:**  indicates that a rule update has been applied. To reapply that rule update to protected computers, right-click the rule update and click **Reapply**.
- **Import a rule update:** Normally, rule updates are imported either [manually](#) or automatically (via [scheduled task](#)). However, if your deployment has no connectivity to the Trend Micro Update servers on the Internet (an "air-gapped" deployment), or if you are asked to do so by your support provider, you can click this button to manually upload and import a security update package.
- **Export a rule update:** Normally, you should not need to export a rule update unless your support provider asks you.
- **Delete a rule update:** Removes the selected rule update from the Deep Security Manager database.

Tip: To limit the number of rule updates that are kept in the Deep Security Manager database, go to **Administration > System Settings > Storage** .

Security update packages must have a valid digital signature. If you try to view or use an invalid package (including old security updates that don't have a signature), then the manager displays an error message. See ["How Deep Security validates update integrity" on page 1610](#).

Configure security updates

You can make the following configurations:

- ["Enable automatic patches for rules" below](#)
- ["Enable automatic Anti-Malware engine updates" on the next page](#)
- ["Enable security updates for older agents" on the next page](#)
- ["Change the alert threshold for late security updates" on page 1616](#)

Enable automatic patches for rules

Trend Micro sometimes updates an existing Deep Security rule to improve performance or fix a bug. To automatically apply these patches, go to **Computer or Policy editor > Settings > General** and in the **Send Policy Changes Immediately** area, select **Automatically send Policy changes to computers** and set the drop-down to **Yes**. If it's not selected, you must manually

apply downloaded rule updates to policies: go to **Administration > System Settings > Updates** and click **Automatically apply Rule Updates to Policies**.

Note: By default, changes to policies are automatically applied to computers.

Enable automatic Anti-Malware engine updates

By default, when you update Deep Security Agent or Virtual Appliance software, then its Deep Security Anti-Malware engine is updated together with it. If you don't update software often, then over time, the Anti-Malware engine might become much older than the malware patterns it uses (which should be frequently updated).

For better protection, you can configure agents and virtual appliances to automatically keep the Anti-Malware engine part of the software updated – an approach more similar to the security updates that it uses.

1. Go to **Computers or Policies**.
2. Double-click a computer or policy.
3. Go to **Settings > Engine Update**.
4. For **Automatically update anti-malware engine**, select **Yes** .

If this setting is disabled, then on **Computer Details > Updates > Advanced Threat Scan Engine**, the **Is Latest** section displays "N/A".

Note: Regardless of this setting, relays always receive the latest Anti-Malware engine updates. This keeps the relay's local protection and engine update source for the same relay group up-to-date. Therefore, you cannot enable or disable engine updates directly on a relay.

Enable security updates for older agents

For some platforms, Deep Security Manager20 supports older versions. See "[Agent platform compatibility](#)" on page 336.

By default, to conserve disk space, Deep Security Relay will not download and distribute security updates for these older agents. To enable security updates for them, go to **Administration > System Settings > Updates**. Select **Allow supported 8.0 and 9.0 Agents to be updated**.

Note: Deep Security Agent 8.0 is no longer supported. This check box only applies to the 9.0 agent.

Change the alert threshold for late security updates

If an update has been downloaded from Trend Micro and available for some time, but computers are not updated yet, an alert occurs. For rule updates, by default, the limit is 30 minutes. For pattern updates, by default, the limit is 1 hour.

If you want to change the time limit for the alert, go to **Administration > System Settings > Alerts** and configure **Length of time an Update can be pending before raising an Alert**.

Disable emails for New Pattern Update alerts

The "New Pattern Update is Downloaded and Available" alert is raised when a security update has not been applied to an agent one hour after Deep Security Manager has downloaded it. The one-hour time span is not configurable. The alert is sent via email when the alert is raised by default.

If you are receiving too many of these email alerts because one hour is not long enough to disperse the updates, you can disable email notifications for this alert. Instead, you can receive email messages for the "Computer Not Receiving Updates" alert for which you can configure the time that passes before the alert is raised.

1. To ensure that Deep Security Manager is configured to automatically download security updates, in Deep Security Manager, click **Administration > Scheduled Tasks**.
2. If there is no scheduled task of type Check for Security Updates, create one (see ["Schedule Deep Security to perform tasks" on page 1766](#)).
3. Click **Administration > System Settings > Updates**. In the Rules section under Security Updates, make sure **Automatically apply Rule Updates to Policies** is selected.
4. Click **Alerts > Configure Alerts**.
5. In the Alert Configuration window, click the **New Pattern Update is Downloadable and Available** alert and then click **Properties**.
6. On the Alert Information window, deselect **Send Email to notify when this alert is raised** and then click **OK**.
7. Click the **Computer Not Receiving Updates** alert and then click **Properties**.
8. Make sure **Send Email to notify when this alert is raised** is selected, and click **OK**. The alert is raised when an update is pending for 7 days.
9. To raise the alert after a different amount of time has passed since the update was pending, click **Administration > System Settings > Alerts**.
10. In the alerts area, use the drop-down to select the period of time, and then click **Save**.

Use a web server to distribute software updates

Deep Security software updates are normally hosted and distributed by relays. However, if you already have a web server, you can provide software updates via the web server instead of a relay. To do this, you must mirror the software repository of the relay on your web server.

Note: Although Deep Security Agents can download their *software* updates from the web server, at least one relay is still required to distribute *security* package updates such as anti-malware and IPS signatures (see "[Apply security updates](#)" on page 1611).

Note: Even though you are using your own web servers to distribute software, you must still go to **Administration > Updates > Software** and import software into the Deep Security Manager's database. Then you must ensure that your software web server contains the same software that has been imported into Deep Security Manager. Otherwise the alerts and other indicators that tell you about available updates will not function properly.

Web server requirements

Disk Space: 20 GB

Ports: [Web server port](#), [relay port](#)

Copy the folder structure

Mirror the folder structure of the software repository folder on a relay-enabled agent. Methods vary by platform and network. For example, you could use `rsync` over SSH for a Linux computer and network that allows SSH.

On Windows, the default location for the relay-enabled agent's software repository folder is:

```
C:\ProgramData\Trend Micro\Deep Security Agent\relay\www\dsa\
```

On Linux, the default location for the Relay's software repository folder is:

```
/var/opt/ds_agent/relay/www/dsa/
```

The structure of the folder is like this:

```
|-- dsa
|   |-- <Platform>.<Architecture>
```

```

|           |-- <Filename>
|           |-- <Filename>
|           |-- ...
|
|       |-- <Platform>.<Architecture>
|           |-- <Filename>
|           |-- <Filename>
|           |-- ...

```

For example:

```

|-- dsa
|   |-- CentOS_<version>.x86_64
|       |-- Feature-AM-CentOS_<version>.x86_64.dsp
|       |-- Feature-DPI-CentOS_<version>.x86_64.dsp
|       |-- Feature-FW-CentOS_<version>.x86_64.dsp
|       |-- Feature-IM-CentOS_<version>.x86_64.dsp
|       |-- ...
|
|   |-- RedHat_EL6.x86_64
|       |-- Agent-Core-RedHat_<version>.x86_64.rpm
|       |-- Feature-AM-RedHat_<version>.x86_64.dsp
|       |-- Feature-DPI-RedHat_<version>.x86_64.dsp
|       |-- Feature-FW-RedHat_<version>.x86_64.dsp
|       |-- ...
|       |-- Plugin-Filter_2_6_32_131_0_15_el6_x86_64-RedHat_
<version>.x86_64.dsp
|       |-- Plugin-Filter_2_6_32_131_12_1_el6_x86_64-RedHat_
<version>.x86_64.dsp
|       |-- ...
|
|   |-- Windows.x86_64
|       |-- Agent-Core-Windows-<version>.x86_64.msi
|       |-- Agent-Core-Windows-<version>.x86_64.msi
|       |-- Feature-AM-Windows-<version>.x86_64.dsp

```

```
|           |-- Feature-AM-Windows-<version>.x86_64.dsp
|           |-- Feature-DPI-Windows-<version>.x86_64.dsp
|           |-- Feature-DPI-Windows-<version>.x86_64.dsp
|           |-- ...
|           |-- Plugin-Filter-Windows-<version>.x86_64.dsp
|           |-- Plugin-Filter-Windows-<version>.x86_64.dsp
|           |-- ...
```

The example above shows only a few files and folders. Inside a complete `dsa` folder, there are more. If you need to save disk space or bandwidth, you don't need to mirror all of them. You're only required to mirror the files that apply to your computers' platforms.

Configure agents to use the new software repository

When the mirror on the web server is complete, configure Deep Security Agents to get their software updates from your web server.

1. On Deep Security Manager, go to **Administration > System Settings > Updates**.
2. In the Software Updates section, enter the URL(s) of the mirror folder(s) on your web server (s).
3. Click **Save**.

Note: Verify that connectivity between agents and your web server is reliable. If the connection is blocked, agents will instead use the relay.

Upgrade Deep Security Manager

Upgrade Deep Security Manager before you upgrade Deep Security Relays, Agents, and Virtual Appliances.

- ["Before you begin" on the next page](#)
- ["Upgrade the manager" on the next page](#)
- ["Upgrade the manager if it's more than two releases old" on page 1621](#)
- ["Upgrade the manager in a multi-node deployment" on page 1621](#)
- ["Upgrade the manager in a multi-tenant environment" on page 1622](#)
- ["What happens when you upgrade?" on page 1622](#)
- ["Post-upgrade tasks" on page 1623](#)

- ["Troubleshoot the manager upgrade \(log files\)" on page 1623](#)
- ["Roll back an unsuccessful upgrade of the manager" on page 1624](#)

Before you begin

Complete these tasks before you upgrade the manager:

1. Check that you're upgrading from a supported version. For details on supported versions, see ["Supported upgrade paths" on page 104](#).
2. **Back up your deployment:**
 - Back up the manager. Make a system restore point or VM snapshot of the server.
 - Back up the manager's database on the database server. The upgrade might make changes to the database schema, so the original database must be backed up.
 - Verify your backups. If you don't have backups, and the installer is interrupted for any reason, you won't be able to [revert your deployment](#). This could require you to re-install your entire deployment.
3. **Check system requirements and sizing guidelines for the new manager:** See ["System requirements" on page 329](#) and ["Sizing" on page 401](#).

Note: The sizing guidelines for Deep Security 20 are different from those for Deep Security 12. Check that your current environment meets the guidelines for Deep Security 20 before upgrading.

4. **Download the manager software:** It's available at <https://help.deepsecurity.trendmicro.com/software.html>.
5. **Check the digital signature on the manager's installer file:** See ["Check the signature on installer files \(EXE, MSI, RPM or DEB files\)" on page 429](#).
6. **Run the readiness check:** See ["Run a readiness check" on page 441](#).

Upgrade the manager

To upgrade the manager, see ["Install the manager" on page 443](#). The referred-to installation instructions will work equally well for upgrades.

Note:

When upgrading from Deep Security 11, if you use Microsoft SQL Server, a data migration step has been added to the installer because the primary key of various tables, including System Events, have been updated from Integer to BigInt in order to avoid reaching the maximum

integer value.

Maintenance windows might need to be longer in some cases. Time required varies by database load, network bandwidth and latency, and the number of existing system events to migrate. Estimate 50,000 - 150,000 system events per minute.

Upgrade the manager if it's more than two releases old

The manager's installer only supports upgrading from two major releases back, so if you're currently on a manager version that's older than that, the upgrade path involves a couple of 'hops': the first hop gets to a version that's a little more recent, and the next gets you to the latest version.

For instructions on how to upgrade from an old manager to a newer one, see the installation guide for the latter:

[Get documentation for other versions](#)

Upgrade the manager in a multi-node deployment

To upgrade the manager

1. Back up each manager node. Make a system restore point or VM snapshot of the server.
2. Stop all nodes.
3. Upgrade the manager on the first node.

Warning: Never run the installer on multiple nodes at the same time. Simultaneous upgrades can corrupt the database. If this happens, you must restore the database backup, and then start the upgrade again.

4. When upgrade is complete for the first node, its service will start. Until other nodes are also upgraded, it will be the only node whose software is compatible with the database, so initially it will be the only available manager. Because it must perform all jobs, you might notice that performance is reduced during this time. On **Administration > System Information**, Network Map with Activity Graph will indicate that other nodes are offline, and that they require an upgrade.

5. Upgrade other nodes. As you upgrade them, they will return online, and begin to share the load again.
 6. If you configured a custom master key, run the [masterkey](#) commands to encrypt existing data on only *one* of the nodes.
-

To upgrade the manager OS

1. Add a new node so that your deployment still has at least one available node while you upgrade old nodes. See ["Add a node" on page 490](#).
 2. Decommission the old nodes. See ["Remove a node" on page 491](#).
 3. Upgrade the OS of decommissioned nodes.
 4. Re-install Deep Security Manager on the old node. This re-connects the node to the existing installation.
-

Upgrade the manager in a multi-tenant environment

See ["Upgrade a multi-tenant environment" on page 482](#) for details.

What happens when you upgrade?

When you upgrade, the installer does the following:

- installs new Deep Security software
- keeps existing computer details, policies, intrusion prevention rules, firewall rules, and so on
- migrates data to new formats, if required
- makes changes to the database schema, if required
- begins migrating event data

When you exit the installer, the upgrade continues. The following occurs:

1. The manager service restarts.
2. The manager continues to migrate event data into the new database schema.

Progress is indicated in the status bar at the bottom of the window, in new events, and (if an error occurs) alerts. Total migration time varies by the amount of data, disk speed, RAM, and processing power.

3. New event data is still recorded, as usual, while the event data is migrated.

Note: Until database upgrade migration is complete, results which include older system event data may be incomplete.

Additional tasks are performed during a multi-node or multi-tenant upgrade. For details, see ["Upgrade the manager in a multi-node deployment" on page 1621](#) and ["Upgrade the manager in a multi-tenant environment" on the previous page](#).

Post-upgrade tasks

After the upgrade, complete the following tasks.

- (Optional) Replace the server certificate

After the upgrade, the manager's server certificate is kept, unless you performed a fresh install. If your certificate was created using a weak cryptographic algorithm, such as SHA-1, consider replacing the certificate. Using stronger cryptography ensures compliance with the latest standards, and provides better protection against the latest exploits and attacks. See ["Upgrade the Deep Security cryptographic algorithm" on page 1595](#) and ["Replace the Deep Security Manager TLS certificate" on page 1570](#).

- (Optional) Remove and re-add vCenter

If you are using Deep Security Virtual Appliance on NSX-T, make sure to [uninstall Deep Security from your NSX-T environment](#) and [re-add NSX-T to the manager](#) to register the updated services. The services that will be registered are:

- E-W Network Introspection
- Endpoint Protection

Troubleshoot the manager upgrade (log files)

If the schema changes are interrupted for any reason, errors are logged in:

```
<install-directory>/DBUpgrade/SchemaUpdate
```

where the default `<install-directory>` is `/opt/dsm` (Linux) or `C:\Program Files\Trend Micro\Deep Security Manager` (Windows).

Within the above directory, two types of files are created:

- `T-00000-Plan.txt` - This file contains all data definition language (DDL) SQL statements that the installer will use to update the schema.
- `T-00000-Progress.txt` - This file contains the schema update progress logs. When the installer is finished, it changes the file name to either `T-00000-Done.txt` (successful update) or `T-00000-Failed.txt` (update failure).

Note: In a multi-tenant environment, the "00000" in the file name is replaced with the tenant number, such as "00001" for tenant t1.

Roll back an unsuccessful upgrade of the manager



If problems occur when you upgrade to Deep Security Manager 20, you can quickly revert to a functional state if you:

- Backed up the database *before* the upgrade
 - Didn't upgrade the agents, relays, or virtual appliances yet (or have VM snapshots or system backups that you made *before* the upgrade)
1. Stop the Deep Security Manager service.
 2. Restore the database.
 3. Restore all Deep Security Manager server nodes.
 4. If you changed the hostname, FQDN, or IP address of the Deep Security Manager during the upgrade, restore them.
 5. Restore the agents, relays, and virtual appliances.
 6. Start the Deep Security Manager service.
 7. Verify connectivity to the Deep Security Manager, including the connection between the manager and agents.

Upgrade Deep Security Relay

Upgrade all your relays before you start to upgrade agents (see "[Best practices for upgrades](#)" on [page 1609](#) for details.) There are two ways to upgrade a relay, as described below.

Upgrade a relay starting from the manager

1. Log in to Deep Security Manager.
2. Identify your Deep Security Relays. Either:
 - Go to **Computers** . In the main pane, look for computers with the relay icon () .
 - Go to **Administration** . On the left, click **Updates > Relay Management** . In the main pane, expand a **Relay Group** . Your relays are displayed with the relay icon () .
3. Double-click the relay that you want to upgrade.
4. Click the **Actions** tab.
5. Click **Upgrade Agent** .

Follow the steps in the wizard that appears. Steps are similar to upgrading a Deep Security Agent, since a relay is just an agent with relay functionality enabled. For details, see ["Upgrade Deep Security Agent" below](#) .

Upgrade a relay by running the installer manually

Sometimes you may not be able to upgrade the relay software from the Deep Security Manager. In these cases, you can upgrade a relay manually. For detailed instructions, see ["Upgrade the agent manually" on page 1629](#) . The referred-to instructions are for agents, but will work equally for relays.

Upgrade Deep Security Agent

Software upgrades can be initiated through Deep Security Manager or a third-party deployment system.

In this topic:

- ["Before you begin an upgrade" on the next page](#)
- ["Upgrade the agent starting from an alert" on page 1627](#)
- ["Upgrade multiple agents at once" on page 1628](#)
- ["Upgrade the agent from the Computers page" on page 1628](#)
- ["Upgrade the agent on activation" on page 1628](#)
- ["Upgrade the agent from a scheduled task" on page 1629](#)

- ["Upgrade the agent manually" on page 1629](#)
- ["Upgrade the agent embedded on the virtual appliance automatically" on page 1632](#)
- ["Upgrade best practices for agents" on page 1633](#)

Before you begin an upgrade

Before you begin an agent upgrade:

1. Check that you're upgrading from a supported version. You can upgrade to Deep Security 20 from:
 - Deep Security 11 LTS (GA version or LTS updates)
 - Deep Security 11 Feature Releases
 - Deep Security 12 LTS (GA version or LTS updates)
 - Deep Security 12 Feature Releases
2. Back up the agent computers that you plan to upgrade. Make a system restore point or VM snapshot of each agent.
3. Import the new agent package into the manager. See ["Import agent software" on page 499](#).
4. Upgrade all Deep Security Relays. See ["Upgrade Deep Security Relay" on page 1624](#).

Warning: You must upgrade all relays before you begin upgrading agents, otherwise, upgrades may fail.

Note: When you upgrade the Deep Security Agent, Deep Security verifies your signature on Deep Security Agent to ensure that the software files have not changed since the time of signing. For more information, see ["Agent package integrity check" on page 1804](#).

Next, review the platform-specific notes below and complete any advised tasks.

Linux agent upgrade notes

Before upgrading the Deep Security Agent on a Linux platform, confirm the OS kernel is supported by the latest version of the agent. See ["Linux kernel compatibility" on page 349](#)

Windows agent upgrade notes

Immediately after upgrading Deep Security Agent 12 or later on Windows with Anti-Malware enabled, be aware that the Anti-Malware engine may appear as 'Offline'. The engine will return to the 'online' state after the first heartbeat following the upgrade.

Solaris agent upgrade notes

- On Solaris 11, if you are upgrading from Deep Security Agent 9.0, you must first upgrade to Deep Security Agent 9.0.0-5616 or a later 9.0 agent, and from there, upgrade to Deep Security Agent 11.0. If you upgrade from an earlier build, the agent may fail to start. If this problem occurs, see ["Fix the upgrade issue on Solaris 11" on page 1922](#).
 - An upgrade on Solaris may take five minutes or longer to complete in some cases.
-

AIX agent upgrade notes

There are no upgrade notes for AIX at this time.

You are now ready to upgrade your agent using any of the methods described in this topic.

Upgrade the agent starting from an alert

When a new agent software version is available, a message appears on **Alerts**.

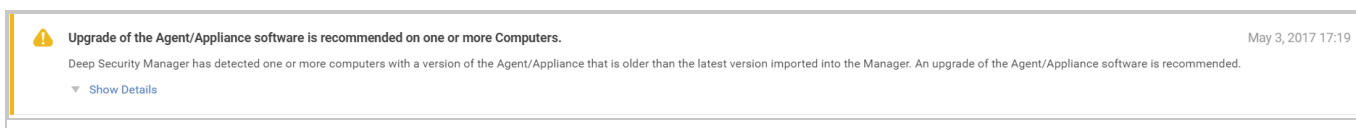

1. In the alert, click **Show Details** and then click **View all out-of-date computers**. **Computers** appears, displaying all computers where **Software Update Status** is **Out-of-Date**. What is considered 'out-of-date' is determined by version control rules you've set up. For details, see ["Configure agent version control" on page 1442](#).
2. Continue with ["Upgrade the agent from the Computers page" on the next page](#) or ["Upgrade the agent manually" on page 1629](#).

Upgrade multiple agents at once

1. In Deep Security Manager, go to **Administration > Updates > Software**.
2. In the main pane, look under the **Computers** section to see whether any computers or virtual appliances are running agents for which upgrades are available. The check is only performed against software that has been imported into Deep Security, not against software available from the Download Center.
3. Click **Upgrade Agent / Appliance Software** to upgrade all out-of-date computers. What is considered 'out-of-date' is determined by version control rules you've set up. For details, see "[Configure agent version control](#)" on page 1442.

Upgrade the agent from the Computers page

1. In Deep Security Manager, go to **Computers**, and then:
 - Right-click the computer(s) that you want to upgrade, and select **Actions > Upgrade Agent Software**.

Or

 - Select the computer(s) that you want to upgrade, click the **Actions** button near the top and select **Upgrade Agent Software**.

Or

 - Double-click a computer that you want to upgrade and on the Computer details dialog box, click the **Upgrade Agent** button.

Warning: You must upgrade your relays before your agents to prevent failures. [Learn more](#). To identify a relay, look for the relay icon (.

2. In the dialog box that appears, select the **Agent Version**. We recommend that you select the default **Use the latest version for platform (X.Y.Z.NNNN)**. Click **Next**.

Upgrade the agent on activation

If Deep Security Agent is installed on Linux or Windows, you can choose to automatically upgrade the agent to the newest software version that's compatible with your Deep Security Manager when the agent is activated or reactivated. For details, see "[Automatically upgrade agents on activation](#)" on page 1462.

Upgrade the agent from a scheduled task

You can create a Scheduled Task to upgrade a group of agents on a set schedule. For details, see [Scheduled Agent Upgrade Task](#).

Upgrade the agent manually

Sometimes you may not be able to upgrade the agent software from the Deep Security Manager. Reasons may include:

- There are connectivity restrictions between the manager and agent computers.
- Your agent software is too old, and the manager doesn't support upgrading it anymore.
- You prefer to deploy upgrades using a third-party system.

If any of the above scenarios describes your situation, you can upgrade the agent by running the installer manually. The method varies by operating system.

Upgrade the agent on Windows

1. Disable [agent self-protection](#) to allow the installer to make modifications to the agent. To disable self-protection:
 - a. In the Deep Security Manager, go to **Computer editor**¹ > **Settings** > **General**.
 - b. In **Agent Self Protection**, deselect **Prevent local end-users from uninstalling, stopping, or otherwise modifying the Agent** or enter a password for a local override.
2. Export the new agent ZIP from the manager. See "[Export the agent installer](#)" on [page 501](#) for instructions. If multiple new agents are available for your platform, choose the latest one.
3. Copy the ZIP to the agent computer and extract it.
4. Double-click the MSI file in the root of the ZIP file. The installer detects the previous agent and performs the upgrade.

Upgrade the agent on Linux

¹To open the Computer editor, go to the Computers page and double-click the computer that you want to edit (or select the computer and click Details).

1. Export the new agent ZIP from the manager. See ["Export the agent installer" on page 501](#) for instructions. If multiple new agents are available for your platform, choose the latest one.
2. Copy the ZIP to the agent computer and extract it.
3. If the computer uses the rpm package manager (Red Hat, CentOS, Amazon Linux, Cloud Linux, SUSE), enter the command:

```
rpm -U <new agent installer rpm>
```

The `-U` argument instructs the installer to perform an upgrade.

4. If the computer uses the dpkg package manager (Debian or Ubuntu), enter the command:

```
dpkg -i <new agent installer dpkg>
```

Upgrade the agent on Solaris

1. Export the new agent ZIP from the manager. See ["Export the agent installer" on page 501](#) for instructions. If multiple new agents are available for your platform, choose the latest one.
2. Copy the ZIP to the agent computer and extract it.
3. Run the installer:

- Solaris 11, one zone (run in the global zone):

```
x86: pkg update -g file:///mnt/Agent-Solaris_5.11-9.x.x-xxxx.x86_64/Agent-Core-Solaris_5.11-9.x.x-xxxx.x86_64.p5p  
pkg:/security/ds-agent
```

```
SPARC: pkg update -g file:///mnt/Agent-Solaris_5.11-9.x.x-xxxx.x86_64/Agent-Solaris_5.11-9.x.x-xxxx.sparc.p5p  
pkg:/security/ds-agent
```

- Solaris 11, multiple zones (run in the global zone):

```
mkdir <path>
```

```
pkgrepo create <path>
```

```
pkgrecv -s file://<dsa core p5p file location> -d <path> '*'
```

```
pkg set-publisher -g <path> trendmicro
```

```
pkg update pkg://trendmicro/security/ds-agent
```

```
pkg unset-publisher trendmicro
```

```
rm -rf <path>
```

- **Solaris 10:** Create an installation configuration file named `ds_adm.file` with the following content, and then save it in the root directory. Next, run this command to install the package:

```
pkgadd -G -v -a /root/ds_adm.file -d Agent-Core-Solaris_5.10_U7-10.0.0-1783.x86_64.pkg
```

Content of `ds_adm.file`

```
mail=
```

```
instance=overwrite
```

```
partial=nocheck
```

```
runlevel=quit
```

```
idepend=nocheck
```

```
rdepend=quit
```

```
space=quit
```

```
setuid=nocheck
```

```
conflict=quit
```

```
action=nocheck
```

```
proxy=
```

```
basedir=default\
```

Upgrade the agent on AIX

1. Export the new agent ZIP from the manager. See ["Export the agent installer" on page 501](#) for instructions. If multiple new agents are available for your platform, choose the latest one.
-

2. Copy the ZIP to the agent computer and extract it. A BFF file becomes available.
3. Copy the BFF file to a temporary folder such as `/tmp` on the AIX computer. For detailed instructions, see ["Install the agent manually" on page 515](#).
4. Upgrade the agent. Use these commands:

```
/tmp> rm -f ./ .toc
```

```
/tmp> installp -a -d /tmp/<agent_BFF_file_name> ds_agent
```

where `<agent_BFF_file_name>` is replaced with the name of the BFF installer file you extracted.

Upgrade the agent embedded on the virtual appliance automatically

The Deep Security Virtual Appliance includes an embedded Deep Security Agent. You can configure Deep Security to upgrade this agent automatically to the latest version during the virtual appliance's deployment into NSX.

Note: If you've already deployed the virtual appliance into NSX, you should upgrade the embedded agent following these alternative instructions: ["Upgrade the agent embedded on the appliance SVM" on page 1648](#).

To configure auto-upgrade of the embedded agent during the virtual appliance deployment into NSX, do the following:

1. In Deep Security Manager, import the latest virtual appliance package. See ["Deploy the appliance \(NSX-T 3.x\)" on page 554](#), or ["Deploy the appliance \(NSX-V\)" on page 589](#)
2. Import the correct virtual appliance patches and agent. See ["Upgrade the agent embedded on the appliance SVM" on page 1648](#). In these instructions, ignore the last instructions to upgrade the embedded agent since it hasn't been deployed yet.
3. Go to **Administration > System Settings > Updates**.
4. In the main pane, find the **Virtual Appliance Deployment** heading, near the bottom.
5. From the **Upon deployment, update Deep Security Virtual Appliances** to drop-down list, select the latest agent version or keep the default of **Latest Available (Recommended)**.

Note: Versions of the agent software that pre-date the imported appliance do not appear in the list.

6. Click **Save**.

The agent that's embedded on the virtual appliance will now be upgraded automatically when you deploy the virtual appliance into NSX. For deployment instructions, see "[Deploy the appliance \(NSX-T 3.x\)](#)" on page 554 or "[Deploy the appliance \(NSX-V\)](#)" on page 589.

Upgrade best practices for agents

If you have critical workloads running on your agent servers, we recommend that you follow these best practices when upgrading:

- Upgrade when the computers are less busy.
- Test the upgrade procedure first in a staging environment before upgrading production servers.
- When upgrading production servers, upgrade one server at a time for the first few servers. Allow a soak period in between each server upgrade.
- After individually upgrading a number of production servers for a given OS version (and application role, on Solaris or AIX), upgrade the remaining servers in groups.
- Also review the "[Best practices for upgrades](#)" on page 1609.

Upgrade Deep Security Virtual Appliance

Trend Micro recommends that you upgrade the Deep Security Virtual Appliance with the newest version to take advantage of the latest security patches, updates, and ongoing support.

The appliance has two parts, which can be upgraded separately:

- the appliance service virtual machine (SVM)
- the Deep Security Agent embedded in the appliance SVM

Note: The term 'appliance SVM' refers to the Deep Security Virtual Appliance virtual machine deployed in your VMware infrastructure.

Topics:

- "[Check if new appliance software is available](#)" on the next page
- "[Before upgrading the appliance](#)" on page 1635
- "[Upgrade the appliance](#)" on page 1637

Check if new appliance software is available

If you're not sure which version of the appliance SVM and embedded agent you're running, or whether new versions are available, read this section to find out. Otherwise, skip this section and proceed directly to ["Upgrade the appliance" on page 1637](#).

Consult these sections to determine whether you need to upgrade:

- ["Determine which versions of the appliance SVM and embedded agent you're using" below](#)
- ["Determine whether a new appliance SVM is available" below](#)
- ["Determine whether a new agent is available" on the next page](#)

Determine which versions of the appliance SVM and embedded agent you're using

1. In Deep Security Manager, click **Computers**.
2. In the search box at the top right, enter `Deep Security Virtual Appliance` to find the appliance virtual machines.
3. Right-click the appliance virtual machine, and click **Details > General**.
 - The **Virtual Appliance Version** property indicates the version of the embedded Deep Security Agent. This agent is deployed on the appliance SVM. Write down this value.
 - The **Appliance (SVM) Version** property indicates the version of the Deep Security Virtual Appliance package that is used to deploy this virtual machine. Write down this value.

Determine whether a new appliance SVM is available

1. In Deep Security Manager, click **Administration**.
2. On the left, expand **Updates > Software > Download Center**.
3. In the main pane, enter `Appliance-ESX` in the search box on the top-right and press Enter. All the appliance SVM software appears.
4. In the main pane, expand the LTS release that matches your Deep Security Manager release.
5. Look for the version in the **VERSION** field and see if it's newer than the installed version.
6. If you find that you need to upgrade, go to ["Upgrade the appliance" on page 1637](#).

Determine whether a new agent is available

1. In Deep Security Manager, click **Administration**.
2. On the left, expand **Updates > Software > Download Center**.
3. In the main pane, in the search box on the top-right, enter the name of an agent that is compatible with your installed appliance SVM. Consult the [compatibility table](#) for guidance. For example, enter `Agent-RedHat_EL7` into the search box. A list of compatible agents appears.
4. In the main pane, expand the latest release to view the latest agent.
5. Look for the version in the **VERSION** field and see if it's newer than the installed version.
6. If you find that you need to upgrade, go to "[Upgrade the appliance](#)" on page 1637.

Before upgrading the appliance

Before you upgrade the Deep Security Virtual Appliance, complete the tasks below.

Review system requirements and supported NSX versions

- Review [this table](#) to see which NSX licenses and versions are supported.
- Review these [system requirements](#). Upgrade NSX, Deep Security Manager, and other required software and hardware, as needed.

Verify the vCenter and NSX account permissions

Make sure the existing vCenter and NSX accounts that you specified in Deep Security Manager during the previous appliance deployment have the correct permissions. For a list of the required permissions, see "[Add a VMware vCenter](#)" on page 681.

Re-register NSX-T

You may need to re-register NSX-T.

To check whether NSX-T needs to be re-registered:

1. Go to NSX-T Manager and click **System > Service Deployments > CATALOG**.
2. Make sure both **Endpoint Protection Policy** and **Intrusion Detection and Prevention Systems** are present, as shown in the image below. If not, it means a re-registration is

required.

Service Definition Name	Version	Functionality	Deployments
Trend Micro Deep Security	12.5	Endpoint Protection Policy Intrusion Detection and Prevention Systems View Less	View

To re-register NSX-T:

1. Uninstall Deep Security from your NSX environment. See "[Uninstall Deep Security from your NSX environment](#)" on page 1679 for details.
2. Re-register NSX in the manager. See "[Add a VMware vCenter](#)" on page 681.

Import the new appliance ZIP into the manager

You must import the new appliance ZIP into the manager.

Tip: As an alternative to importing the appliance ZIP, you can place the OVF file at a URL location to make it faster for NSX to download. For details, see "[Configure the appliance OVF location](#)" on page 626.

1. Go to:

<https://help.deepsecurity.trendmicro.com/software.html>

2. Download the Deep Security Virtual Appliance package. Check the version requirements in [system requirements](#).

You can import multiple versions of the appliance. The manager will choose the newest package.

3. On Deep Security Manager, go to **Administration > Updates > Software > Local**.
4. Click **Import** and upload the package to Deep Security Manager.

On import, Deep Security Manager *also* automatically downloads and imports an agent that is compatible with the operating system of the virtual appliance VM. This agent has the same protection modules as Deep Security Agent for 64-bit Red Hat Enterprise Linux.

5. If you want to specify a different embedded agent, go to **Administration > System Settings**

> **Updates** and look for **Virtual Appliance Deployment**. By default, the **Virtual Appliance Deployment** option is set to **Latest Available (Recommended)**. This indicates to the manager to upgrade the virtual appliance to use the newest imported, embedded agent. Change this setting, as required.

Next steps

You have completed the pre-upgrade steps and must now continue with the upgrade. You must go to one of the following sections depending on your scenario:

- If you [re-registered NSX-T](#), the appliance was removed. This means you'll need to deploy a fresh appliance (not upgrade it). For next steps, go to ["Deploy the appliance \(NSX-T 3.x\)" on page 554](#).
- If you didn't re-register NSX-T, you are now ready to upgrade the appliance. Go to ["Upgrade the appliance" below](#).

Upgrade the appliance

After completing the pre-upgrade tasks, you are ready to upgrade the appliance. You have a few upgrade options:

- Option 1: ["Upgrade an existing appliance SVM automatically" below](#).
- Option 2: ["Upgrade an existing appliance SVM manually" on page 1641](#). Use this option if protection loss of your guest VMs during the upgrade is *unacceptable*.
- Option 3: ["Upgrade the agent embedded on the appliance SVM" on page 1648](#). Use this option if you want the latest protection features offered by the newest agent software without having to complete a full appliance SVM upgrade.

If you are using NSX-T, you can use Option 2 or 3.

If you are using NSX-V, you can use any Option.

See also ["Upgrade the NSX license for more Deep Security features" on page 1651](#).

Upgrade an existing appliance SVM automatically

With this upgrade option, your guest VMs lose protection during the upgrade process, which takes five to fifteen minutes depending on the resources of your VMware components and network stability. If you would like to maintain protection of the guest VMs, see instead ["Upgrade an existing appliance SVM manually" on page 1641](#).

Note: Any resource adjustments or custom configurations you may have made to the current appliance SVM, such as extending the CPU or memory or changing a password, will not be carried over to the new appliance SVM after the upgrade. You will need to manually re-apply these configurations when the upgrade finishes.

To upgrade the appliance SVM automatically, follow these steps:

- "Step 1: Upgrade the appliance SVM in the manager" below
- "Step 2: Check that the upgrade succeeded" on page 1641

Step 1: Upgrade the appliance SVM in the manager

1. In Deep Security Manager, click **Computers** at the top.
2. Find the ESXi host where your existing appliance SVM is located. The ESXi host has its **PLATFORM** column set to `VMware ESXi <version_build>` (see image below). (It is *not* a computer with a PLATFORM of Deep Security Virtual Appliance.)
3. Right-click the ESXi host and select **Actions > Upgrade Appliance (SVM)**.

Tip: You can use Shift+click to select multiple ESXi hosts, if you want to upgrade several at once.

Note: The **Upgrade Appliance (SVM)** option is only available if the latest virtual appliance package in **Local Software** is newer than the one that's currently in use. To make the option available, try [importing the latest appliance package](#). If that doesn't work, it's likely because you're already using the latest version of the appliance SVM. To check, look at the **Appliance (SVM) Version** property on the computer details page of the appliance virtual machine.



The **Upgrade Appliance (SVM)** page appears with a check box, warnings, and a note.

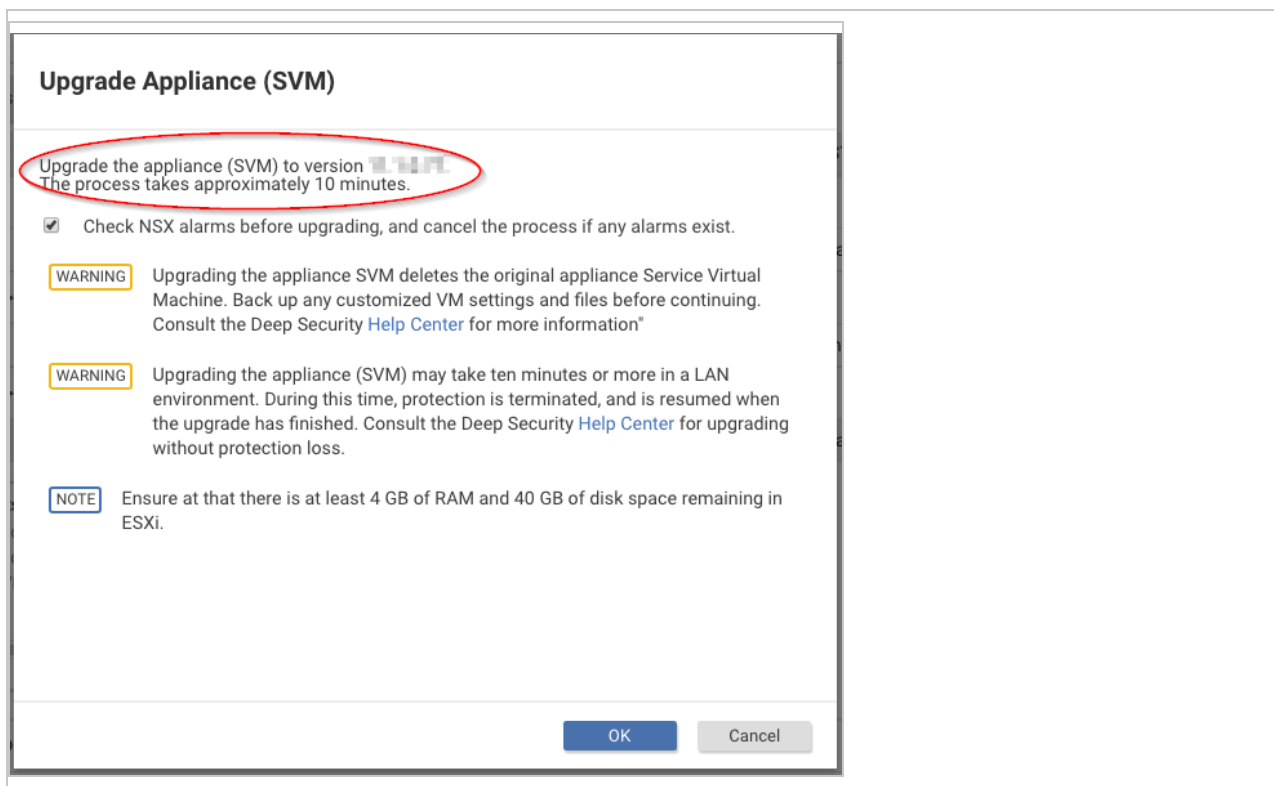

Note: During the upgrade, the appliance (SVM) will be shut down for about 3 - 10 minutes depending on your vCenter and ESX resources.

4. (Optional.) Select **Check NSX alarms before upgrade, and cancel the process if any alarms exist** if you want the manager to check the service status from NSX Manager before the upgrade begins. Deselect the check box if you want to skip the check and proceed with the upgrade despite possible alarms.
5. Review the warnings and note on the page.
6. Click **OK**.

The upgrade process begins, including a pre-upgrade service status check, if you enabled it.

7. (Optional.) Still in the manager, go back to the **Computers** page, find your ESXi host, and look at its **TASK(S)** column to view the status of the upgrade.

Note: If you previously shift+clicked several ESXi hosts on which to perform an upgrade, the ESXi hosts are processed sequentially (one at a time). You can look at the **TASK(S)** column to find out which server is currently being processed.

The **TASK(S)** column displays one of the following:

- **Upgrading Appliance (SVM) (Pending):** The manager has received the upgrade request, but has not yet put it into the queue.
 - **Upgrading Appliance (SVM) (In Queue):** The manager has queued the process, and will start the upgrade soon.
 - **Upgrading Appliance (SVM) (In Progress):** The manager is processing the upgrade.
8. (Optional.) Still in the manager, go to the **Computer Details** page of one of your ESXi hosts and click the **System Events** tab to verify that the upgrade is proceeding successfully.

Below is a sample of the system events you'll see when an upgrade is successful. For more events, see [this complete list of appliance SVM upgrade events](#).

TIME ▾	LEVEL	EVENT ID	EVENT
November 28, 2018 10:51:49	Info	2963	Appliance (SVM) Upgraded
November 28, 2018 10:48:38	Info	2961	Appliance (SVM) Upgrade Started
November 28, 2018 10:48:38	Info	2960	Appliance (SVM) Upgrade Requested

Note: If you see the **Appliance (SVM) Upgrade Failed** system event, see "[Troubleshooting the 'Appliance \(SVM\) Upgrade Failed' system event](#)" below.

Troubleshooting the 'Appliance (SVM) Upgrade Failed' system event

If you see the **Appliance (SVM) Upgrade Failed** system event, review its detailed description for the reason and possible fix. In the worst case scenario, you can go to the NSX Manager console and click the **Resolve** button (see the image below). Clicking this button manually resolves any alarms and redeploys the appliance. Guest VMs are activated according to how you set up activation when you deployed your old Deep Security Virtual Appliance. For details on activation set up, see the activation section of "[Deploy the appliance \(NSX-V\)](#)" on page 589.

The screenshot shows the 'Installation and Upgrade' section of the NSX Manager console. It includes tabs for Management, Host Preparation, Logical Network Preparation, Service Deployments, and Upgrade. The 'Service Deployments' tab is active, showing a table of network and security services. The table has columns for Service, Version, Installation Status, Service Status, Cluster, Datastore, Port Group, and IP Address Range. Two services are listed: 'Trend Micro Deep Security' (version 11.0) and 'Guest Introspection' (version 6.4.0.7412345). Both have an 'Installation Status' of 'Failed' and a 'Service Status' of 'Unknown'. A red arrow points from the word 'Resolve' to the 'X' icon in the service deployment controls.

Service	Version	Installation Status	Service Status	Cluster	Datastore	Port Group	IP Address Range
Trend Micro Deep S...	11.0	Failed	Unknown	Cluster_1	Specified on-host	Specified on-host	IP pool
Guest Introspection	6.4.0.7412345	Failed	Unknown	Cluster_1	Specified on-host	Specified on-host	IP pool

Step 2: Check that the upgrade succeeded

The appliance SVM should be upgraded successfully. Go to the manager's **Computers** page and double-check that the appliance SVM and all the guest VMs are back in their protected state (green dot).

Upgrade an existing appliance SVM manually

With a manual upgrade, you'll use the vMotion mechanism to preserve the guest VMs' protection while the upgrade occurs.

To upgrade the appliance SVM, follow these steps:

- ["Step 1: Review or restore identified files" below](#)
- ["Step 2: Migrate guest VMs to another ESXi host" below](#)
- ["Step 3: Upgrade your old appliance SVM" on the next page](#)
- ["Step 4: Check that maintenance mode was turned off" on page 1647](#)
- ["Step 5: Check that the new appliance SVM is activated" on page 1647](#)
- ["Step 6: Final step" on page 1648](#)

Step 1: Review or restore identified files

1. [Review or restore identified files](#) as necessary because identified files will be lost when you move your VMs or delete the Deep Security Virtual Appliance.

Step 2: Migrate guest VMs to another ESXi host

Note: Skip this section if you are using NSX-T 3.x.

For brevity, this procedure uses these terms:

- `ESXi_A` is the ESXi server with the virtual appliance that you want to upgrade.
- `ESXi_B` is the ESXi server where guest VMs are migrated to while the appliance

SVM upgrade occurs. We assume it is under the same cluster as `ESXi_A`.

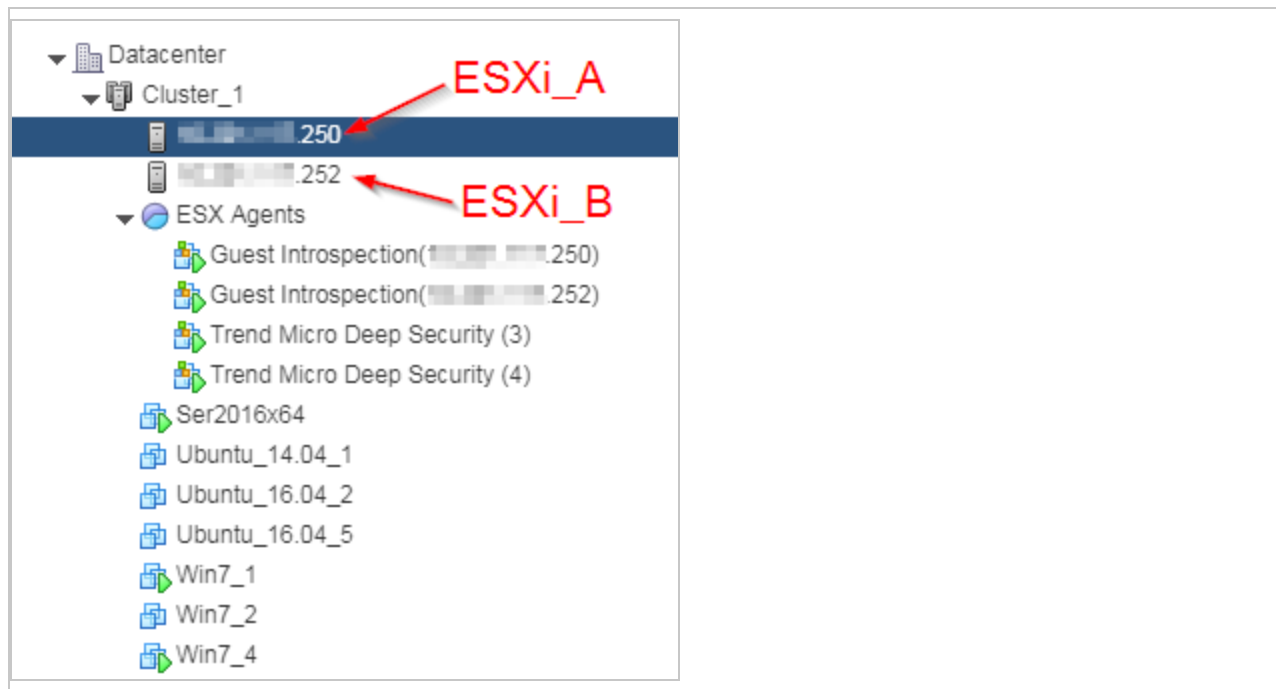

1. Enable DRS for the cluster and make sure it has an automation level of **Fully Automated**. See [this VMware article](#) for details.
2. Find `ESXi_A` and [place this ESXi server in maintenance mode](#).

When you enter maintenance mode:

- `ESXi_A`'s guest VMs are migrated automatically (using [vMotion](#)) to `ESXi_B` in your cluster.
- The Deep Security Virtual Appliance that is protecting `ESXi_A` is shut down automatically.
- Your guest VMs can no longer be powered on until `ESXi_A` is out of maintenance mode.

Step 3: Upgrade your old appliance SVM

NSX-V instructions

1. Go to **VMware vSphere Web Client > Hosts and Clusters**.
2. Find the **Trend Micro Deep Security** appliance SVM that is powered off. It's the one without a green arrow (shown in the following image). The appliance

SVM was automatically powered off when you put the corresponding ESXi server into maintenance mode.

3. Right-click the **Trend Micro Deep Security** appliance SVM that is powered off and select **Delete from Disk**.
-

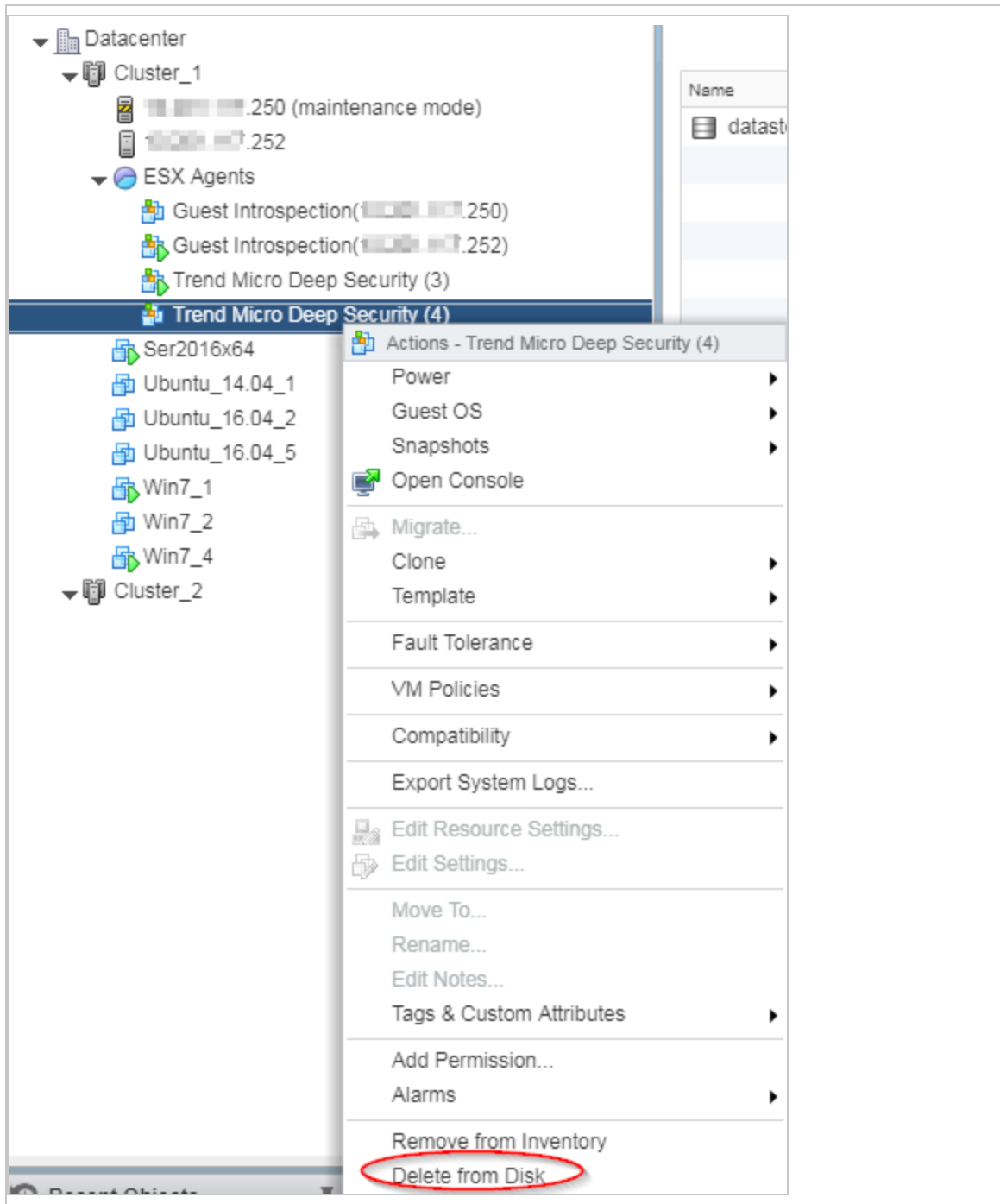

- If you see a **Confirm Delete** message, click **Yes**.

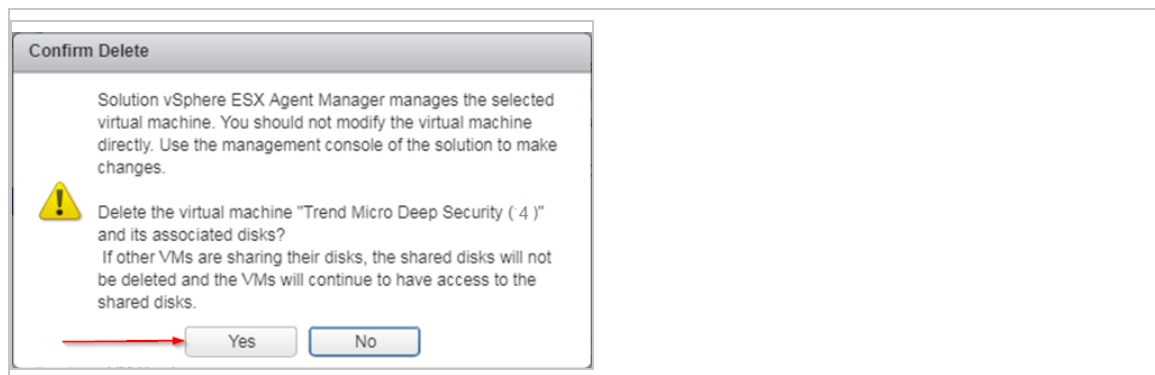

- If the deletion fails with this message...

This operation not allowed in the current state

Do this:

- Right-click the **Trend Micro Deep Security** appliance SVM again, and this time select **Remove from Inventory** (which appears just above **Delete from Disk**). This removes the appliance SVM from vCenter but preserves it in the datastore.
- In the navigation pane, select the datastore tab and select the datastore where the old virtual appliance resides.
- In the main pane, select the **Files** tab.
- Right-click the old appliance SVM folder and select **Delete File**.

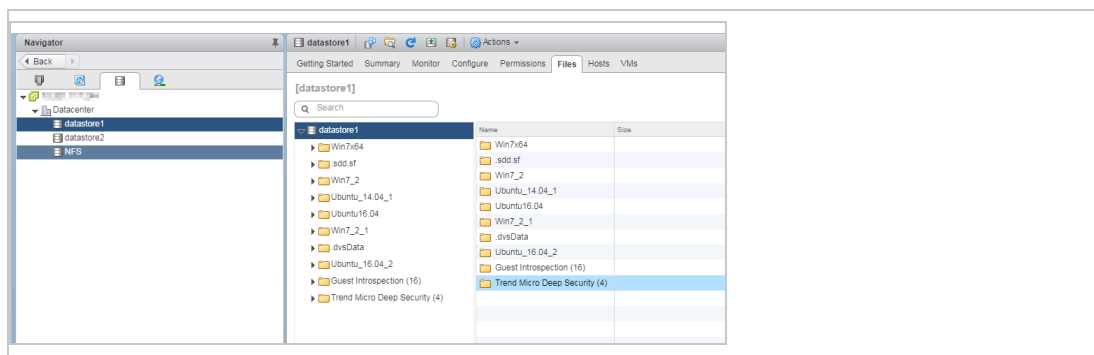

- Open VMware vSphere Web Client, and go to **Home > Networking and Security > Installation > Service Deployments**.

You see the following:

- The deleted Trend Micro Deep Security appliance SVM **Installation Status** column shows **Failed**.
- If you are in maintenance mode, the **Guest Introspection** service also shows as **Failed**.

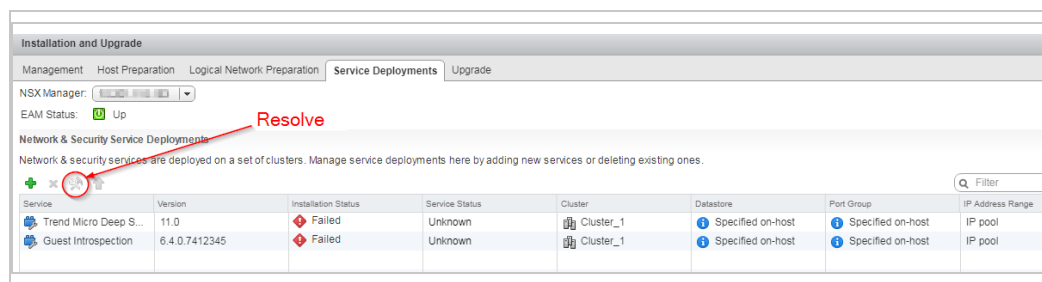

- Click the **Resolve** button on the **Guest Introspection** service if its **Installation Status** is **Failed**. The **Failed** status changes to **Enabling** and then to **Succeeded**. The Guest Introspection service is powered on and maintenance mode is exited.
- Click the **Resolve** button on the **Trend Micro Deep Security** service that is **Failed**. The **Failed** status changes to **Enabling** and then to **Succeeded**. The following occurred:
 - The Trend Micro Deep Security appliance SVM was redeployed with the latest software that you loaded into Deep Security Manager.
 - The appliance SVM was activated.
 - The embedded agent on the appliance SVM was auto-upgraded to the latest compatible version in **Local Software** by default.

This ends the NSX-V instructions. You can proceed to ["Step 4: Check that maintenance mode was turned off"](#) on the next page.

NSX-T 3.x instructions

In NSX-T Manager, go to **System > Service Deployments > DEPLOYMENT**.

Click the menu icon (three dots) > **Change Appliance**.

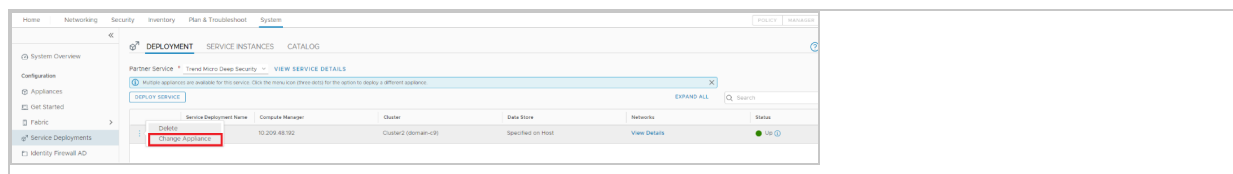

c. Select the appliance that you want to update and click the **UPDATE** button.

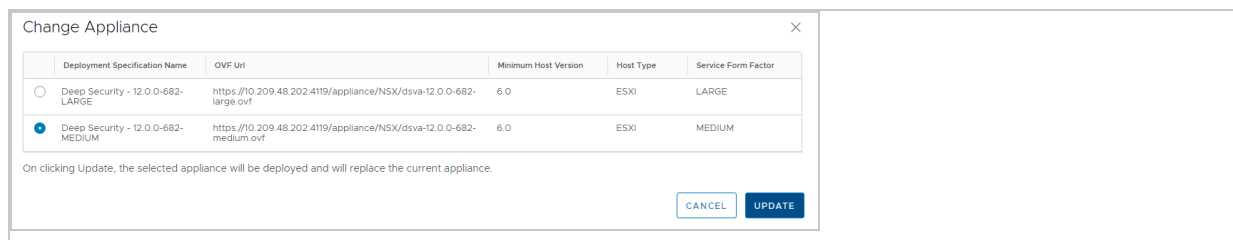

Wait for the upgrade process to complete.

Step 4: Check that maintenance mode was turned off

Note: Skip this section if you are using NSX-T 3.x.

- [Check that maintenance mode was turned off](#) if you enabled it previously. If it is still on, turn it off now.

Step 5: Check that the new appliance SVM is activated

1. In Deep Security Manager, at the top, click **Computers**.
2. Find **Trend Micro Deep Security** in the list and double-click it. This is the appliance.
3. Check the following:
 - a. Check that the status is set to **Managed (Online)**. This indicates that the agent was successfully activated.
 - b. Check that the **Virtual Appliance Version** is set to the version of the embedded Deep Security Agent. This version should match the version of the newest agent software found under **Administration > Updates > Software > Local** or a specific version you set in **Administration > System Settings > Updates > Virtual Appliance Deployment**.
 - c. Check that the **Appliance (SVM) Version** is set to the version of the newest Deep Security Virtual Appliance package under **Administration > Updates > Software >**

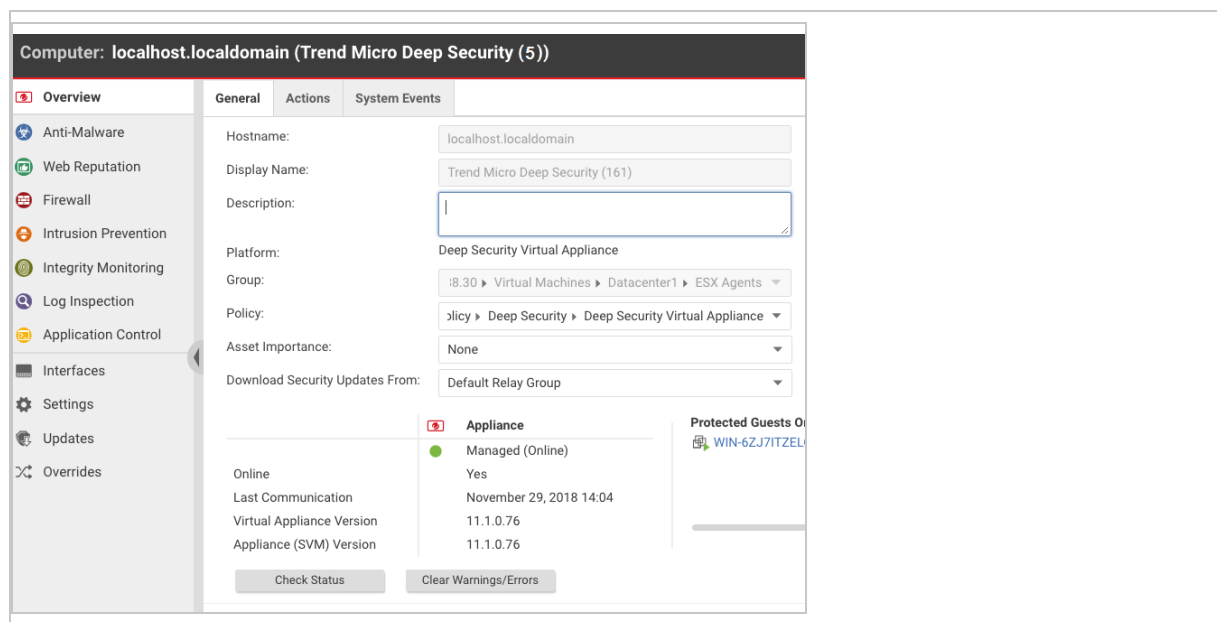
Local.

You have now upgraded your appliance SVM.

Step 6: Final step

1. Repeat all the steps in this section, starting at ["Step 1: Review or restore identified files"](#) on [page 1641](#) and ending at ["Step 5: Check that the new appliance SVM is activated"](#) on the [previous page](#) for each appliance SVM that needs to be upgraded.

Guest VMs are activated according to how you set up activation when you deployed your old Deep Security Virtual Appliance. For details on activation setup, see the activation section in ["Deploy the appliance \(NSX-T 3.x\)"](#) on [page 554](#), or ["Deploy the appliance \(NSX-V\)"](#) on [page 589](#).

Upgrade the agent embedded on the appliance SVM

You can upgrade just the Deep Security Agent that's embedded on the appliance SVM without redeploying the appliance SVM.

Note: When you upgrade just the embedded agent, the appliance SVM's original end-of-support date remains in effect. For details, see ["Deep Security LTS life cycle dates"](#) on [page 109](#)

Follow these instructions to upgrade the embedded agent on the appliance SVM.

1. ["Determine which versions of the appliance SVM and embedded agent you're using"](#) on [page 1634](#). You'll need this information to complete the remaining steps in this procedure.
2. Import the compatible agent:
 - a. Still in Deep Security Manager, on the left, expand **Updates > Software > Download Center**.
 - b. Select the agent software that is compatible with your appliance SVM. Consult the [compatibility table](#) that follows for guidance.
 - c. Click the button in the **Import Now** column to import the agent into Deep Security Manager.
 - d. On the left, click **Local Software** to verify that the agent was imported successfully.

You have now imported the Deep Security Agent that is compatible with your appliance SVM version. You are ready to upgrade the agent on the appliance SVM.

3. Upgrade the agent on the appliance SVM:
 - a. Click **Computers** and double-click your appliance computer.
 - b. Click **Actions > Upgrade Appliance**.
 - c. Select the agent version to install on the appliance. This is the agent you just imported.
 - d. Click **OK**.
4. Click **Events & Reports** and search on [710](#) to find the report about the installation of the update file.

You have now upgraded the agent on the appliance SVM.

Compatibility table: appliance, agent

Appliance SVM version	Image OS	Compatible agent software
Appliance-ESX-11.0 or higher	CentOS 7	Agent-RedHat_EL7-<version>.x86_64.zip where <version> is the version of the agent software. Select the latest version. This version of the agent will be used as the embedded agent.

Upgrade the database

If you're planning on upgrading Deep Security Manager, you may also need to upgrade the Deep Security database. Check this list of [currently-supported databases](#), and then, if required,

migrate to a new database following the instructions below.

The upgrade path

The upgrade path for the database is as follows:

1. Upgrade the database software first.
2. Upgrade Deep Security Manager.

The database you choose must be supported by both the *new* and *currently-installed* version of Deep Security Manager. See these lists:

- [Databases supported by the current release of the manager.](#)
- [Databases supported by previous versions of the manager.](#) (The adjacent link takes you to a page that provides access to the documentation for previous releases. You can drill down into the documentation to find database support.)

Upgrade the database

To upgrade the database, follow these instructions:

Warning: To prevent data loss, complete the database migration before upgrading the Deep Security Manager software.

1. Stop the Deep Security Manager service. Deep Security Agents continue with their current protection policies while the manager is stopped.
2. Back up the database(s).
3. Back up the database connection settings file: `[Deep Security install directory]/webclient/webapps/ROOT/WEB-INF/dsm.properties`
4. Migrate to the new database server. For specific requirements, see "[Database requirements](#)" on page 434.
5. If the migration did not preserve existing databases, load the database backup(s) into the new database engine.
6. If required, edit `dsm.properties` to use the migrated database.
7. Restart the Deep Security Manager service.

Error: The installer could not establish a secure connection to the database server

When installing or upgrading Deep Security Manager, the following error message can occur if you are using Microsoft SQL Server as your Deep Security database:

The installer could not establish a secure connection to the database server. Please upgrade or configure your database server to support TLS 1.2 encryption.

The error message appears if the `java.security` file on the Deep Security Manager includes `TLSv1` and `TLSv1.1` in the `jdk.tls.disabledAlgorithms=` setting, which disables early TLS and only allows TLS 1.2. (The `java.security` file is set this way if you are doing a fresh install of Deep Security Manager 11.1 or higher, where only TLS 1.2 is allowed, or if you are upgrading and previously [enforced TLS 1.2](#).) During the upgrade or installation, the database drivers on the manager try to communicate with the SQL Server using TLS 1.2, and if your SQL Server version does not support TLS 1.2, you'll see this error.

To solve the problem, you must upgrade your SQL Server database to a version that supports TLS 1.2 and then retry the Deep Security Manager installation or upgrade. For a list of SQL Server versions that support TLS 1.2, see [this Microsoft article](#).

Upgrade the NSX license for more Deep Security features

If you want to use the Deep Security Firewall, Intrusion Prevention, or Web Reputation features with Deep Security Virtual Appliance, you'll need to use a license that supports VMware's network functionality. Network functionality is supported with the following license types:

- NSX Advanced
- NSX Enterprise
- NSX Data Center Advanced
- NSX Data Center Enterprise Plus
- NSX Data Center for Remote Office Branch Office

If you're using another license type, you'll have to upgrade it. See:

- ["Upgrade your NSX-T 3.x license" on the next page](#)
- ["Upgrade your NSX-V license" on the next page](#)

Tip: As an alternative to upgrading your NSX license, you can deploy Deep Security Agents on your guest VMs to get the above-mentioned features. For details, see [this table](#) as well as ["Choose agentless vs. combined mode protection"](#) on page 548.

Upgrade your NSX-T 3.x license

1. Log in to NSX-T Manager.
2. Click **System > Licenses**.
3. Click **Add**, enter the license key, and click **Add**.
4. Log out and log back in to NSX-T Manager. The new license is applied.

You can now use the Deep Security features that rely on VMware's network functionality, namely, the Firewall, Intrusion Prevention, and Web Reputation features. You can continue to use the Anti-Malware and Integrity Monitoring features, which were available to you previously.

Upgrade your NSX-V license

- ["Step 1: Upgrade your NSX license" below](#)
- ["Step 2: Remove Deep Security from NSX completely" on page 1656](#)
- ["Step 3: Redeploy the Deep Security Virtual Appliance" on page 1656](#)

Step 1: Upgrade your NSX license

1. In your vSphere Web Client, go to **Home > Administration > Licenses**.
2. In the main pane, click **Assets**, and then click the **Solutions** button.

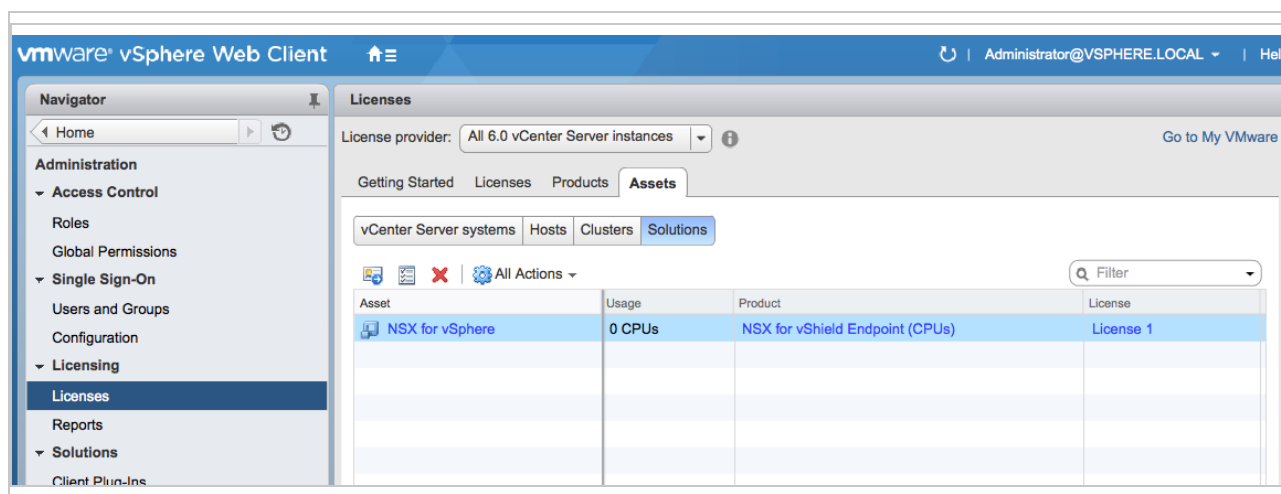

3. Right-click **NSX for vSphere** and select **Assign License**.

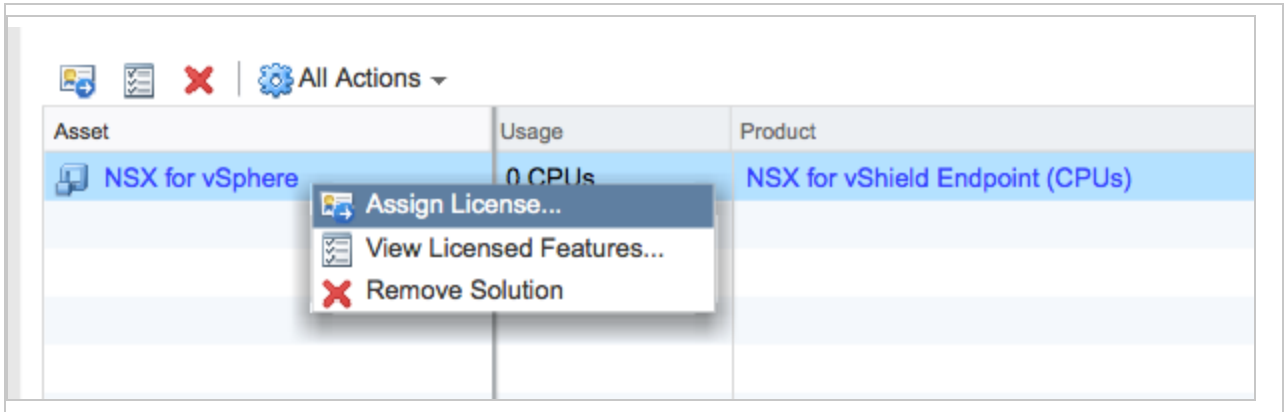

4. Click the green + on the left to create a new license.

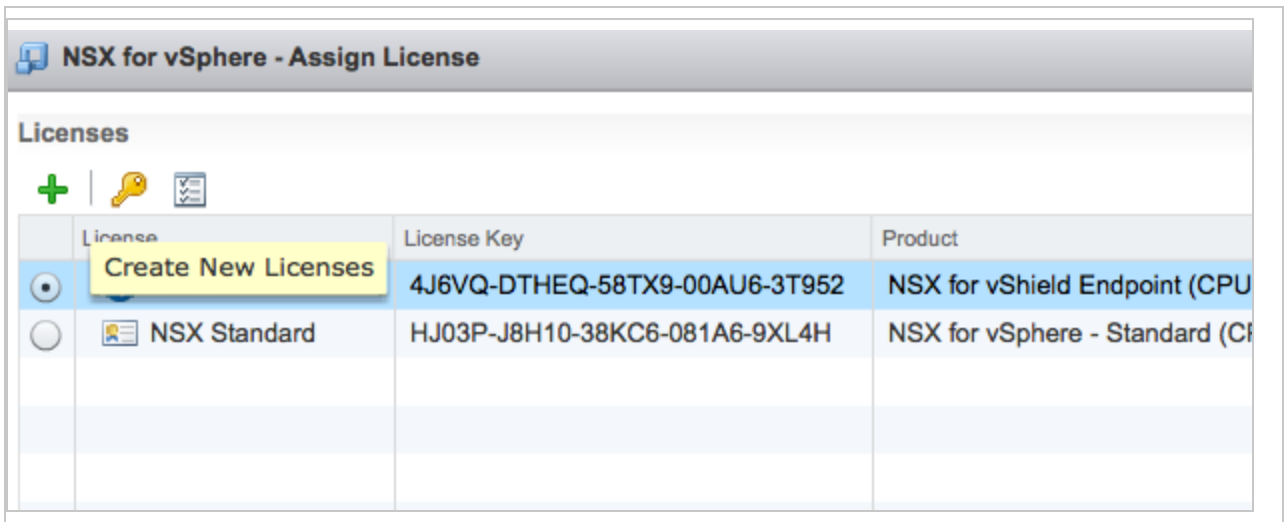

A wizard appears, guiding you through the process of adding a license key.

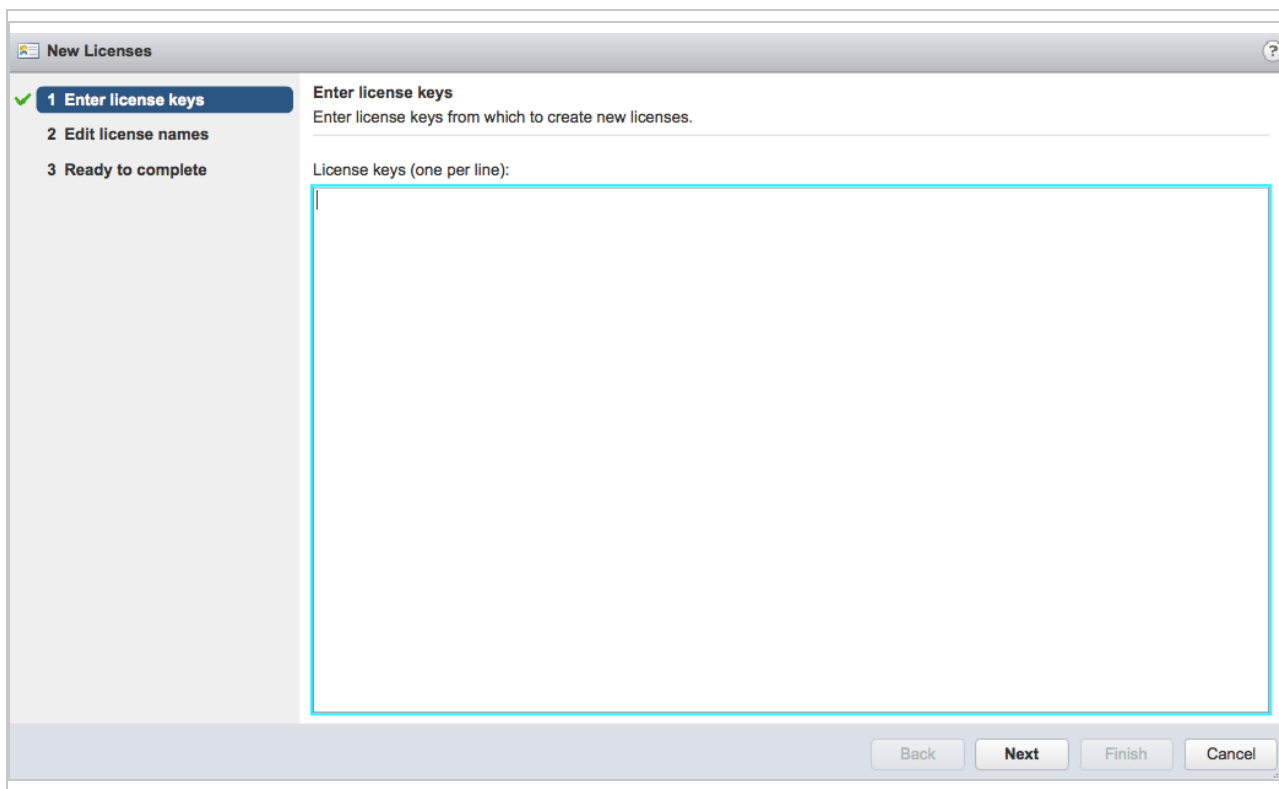

5. In the wizard, enter the NSX Advanced, NSX Enterprise, NSX Data Center Professional, NSX Data Center Advanced, NSX Data Center Enterprise Plus, or NSX Data Center fore Remote Branch Office license key and a license name. At the end of the wizard, click **Finished**.

The new license appears in the list on the **Assign License** page.

6. Select the new license and click **OK**.

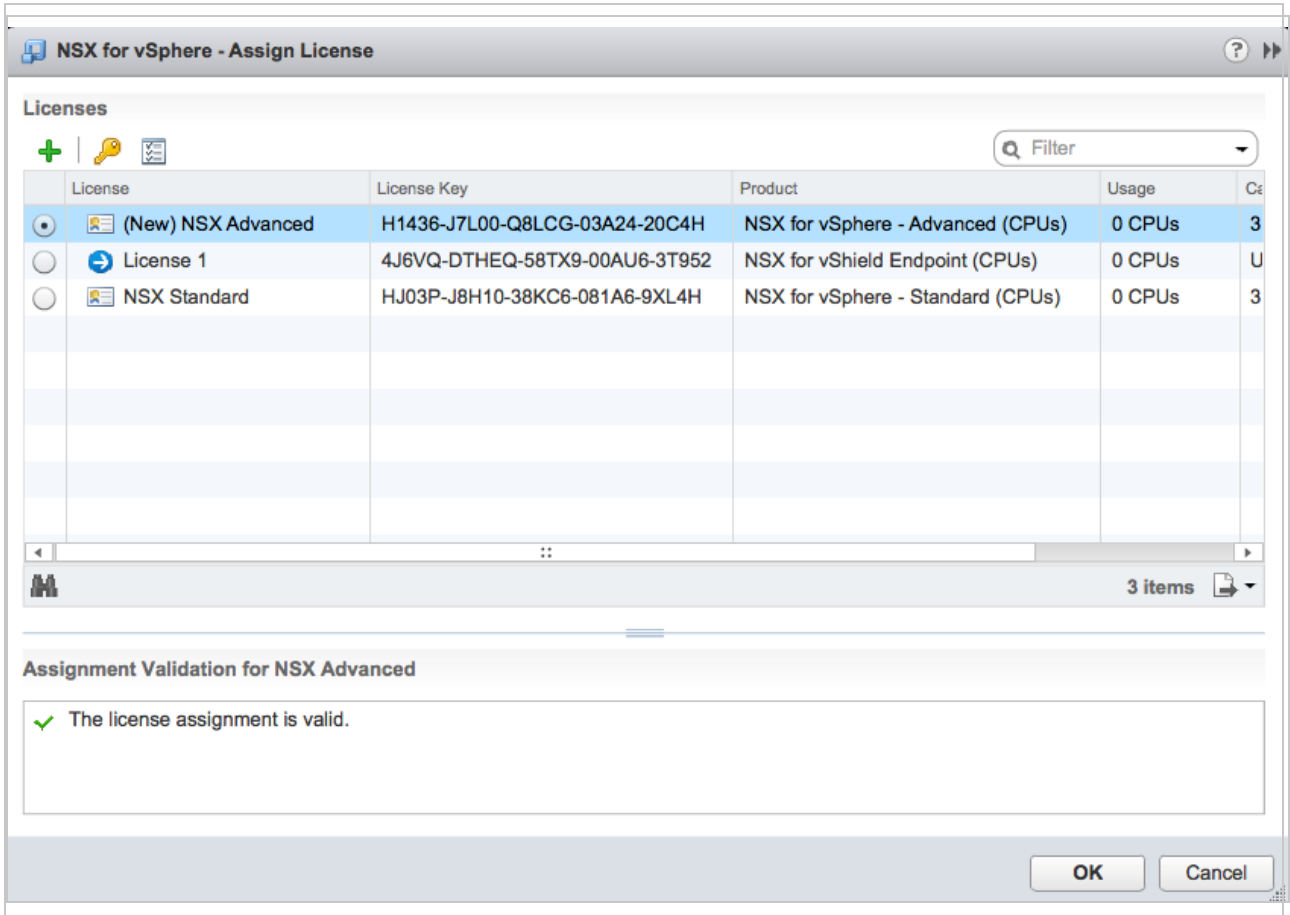

The new NSX license is now in use.

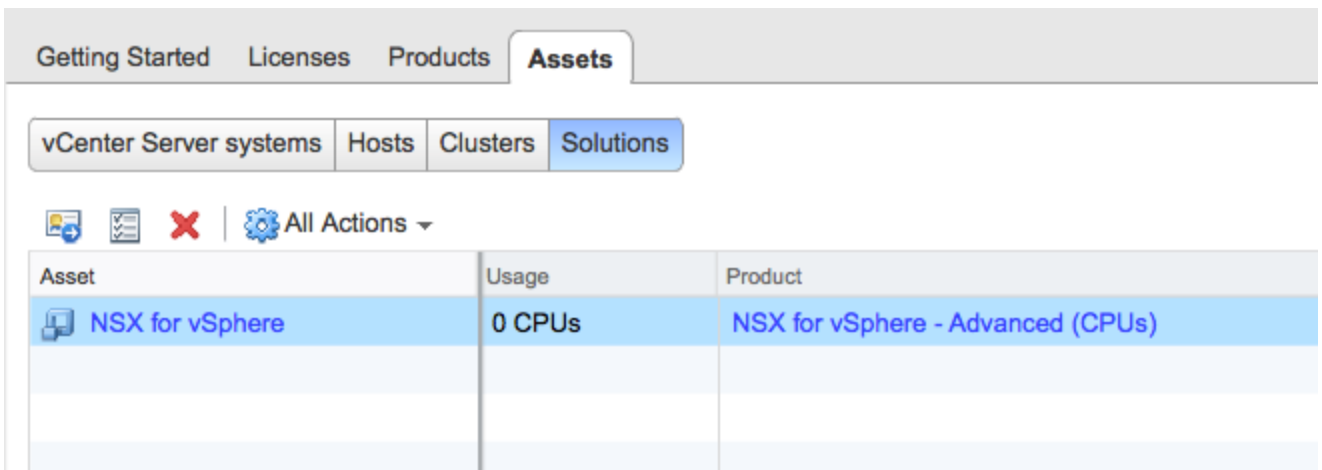

Step 2: Remove Deep Security from NSX completely

In order for the new license to take effect, you'll need to remove Deep Security entirely from NSX. To remove the Deep Security from NSX, see "[Uninstall Deep Security from your NSX environment](#)" on page 1679.

Step 3: Redeploy the Deep Security Virtual Appliance

After completely removing Deep Security from NSX, you'll need to redeploy the Deep Security Virtual Appliance. To redeploy, follow all the steps in "[Deploy the appliance \(NSX-V\)](#)" on page 589.

You can now use the Firewall, Intrusion Prevention, and Web Reputation features, and you can continue to use the Anti-Malware and Integrity Monitoring features, which were available to you previously.

Migrate an agentless solution from NSX-V to NSX-T

The Deep Security Virtual Appliance will reach [end of extended support \(EOL\)](#) on 31-Dec-2027 or VMware's end of support date for NSX-4.X, whichever comes first.

This document describes how to migrate an existing agentless solution on an NSX-V environment to NSX-T 3.0 or newer.

The migration procedure depends on how your environment is configured. Refer to [Co-existence of NSX for vSphere and NSX-T](#) in the VMware documentation for descriptions of various configurations. The sections below contain instruction on how to migrate for either Use Case 1 or Use Case 2 from the VMWare document.

	Use Case 1	Use Case 2
Location	VMware NSX-V and NSX-T are registered on separate vCenter Servers.	VMware NSX-V and NSX-T are registered on the same vCenter Server, to protect different clusters.

	Use Case 1	Use Case 2
Example		
Migration instructions	See "Migration scenario 1" below	See "Migration scenario 2" on page 1659

Migration scenario 1

Follow the steps below:

- "Before migration" below
- "Step 1: Prepare the NSX-T infrastructure for migration" on the next page
- "Step 2: Import a new appliance" on the next page
- "Step 3: Migrate" on the next page
- "Step 4: Verify the new deployment and its security features" on page 1659
- "Step 5: Uninstall NSX-V from Deep Security Manager" on page 1659

Before migration

1. Review the [system requirements](#). In particular:
 - Deep Security Manager must be version 20 LTS Update 2020-11-26 or newer.
 - NSX-T must be version 3.0 or newer.
 - You should already have a Deep Security Manager with an existing vCenter connector binding to NSX-V 6.4.x.

2. Refer to Use Case 1 in [Co-existence of NSX for vSphere and NSX-T](#) in the VMware documentation to configure another vCenter Server (for example, VC-2) and register it to the NSX-T Manager.
3. Refer to your VMware documentation to arrange ESXi hosts and clusters for NSX-T management.
4. If your NSX-V includes an Edge cluster, refer to [NSX Edge Networking Setup](#) in the VMware documentation and configure the Edge cluster for Routing or Bridge mode on NSX-T.
5. Confirm network connectivity before continuing with the migration process.

Step 1: Prepare the NSX-T infrastructure for migration

Follow the steps in [Prepare Fabric settings](#) and configure NSX-T. If you have already added the new vCenter to NSX-T (for example, the VC-2 mentioned in the previous section), you can skip the "Configure a Compute Manager" step.

Step 2: Import a new appliance

Next, in Deep Security Manager, [import a new Deep Security Virtual Appliance](#).

Step 3: Migrate

1. In Deep Security Manager, add the new vCenter (VC-2 in the example above) and NSX-T. For instructions, see [Add a new vCenter connector](#).
2. [Deploy the Deep Security Virtual Appliance on NSX-T](#).
3. NSX-T has additional requirements for Guest VM activation and security policy assignment, compared to NSX-V. Complete these tasks:
 - a. ["Update the security group for NSX-T" on page 1663](#)
 - b. ["Migrate security policies from NSX-V to NSX-T" on page 1670](#)
 - c. [Prepare for activation](#).

If you used [Method 1 or Method 2 when preparing your NSX-V environment](#), you may need to modify the "Assign Policy" or "Conditions" of existing event-based tasks to activate the Guest VM automatically.

Note: When initiating a security policy migration and creation of service profiles on NSX-T, the guest VMs under the NSX-V clusters may undergo protection loss. This is because the NSX security group binding is a part of the migration. The protection will resume after the Guest VMs are migrated to an NSX-T cluster that has the NSX-T configurations ready.

4. Migrate the Guest VMs:
 - a. Link both vCenter Servers on the same SSO domain to support Cross vCenter migration. See [Requirements for Migration Between vCenter Server Instances](#) in the VMware documentation.
 - b. Use vMotion to move the guest VMs from the original vCenter to the new one. For information, see [vMotion between VDS/VSS and NSX-T switch](#).
 - c. If you were using Network Introspection on NSX-V, after vMotion is complete and the new vCenter is on the NSX-T network, the Guest VMs need to connect at least one NIC to the Logical Switch (overlay mode) to enable the network security features on NSX-T.
5. In Deep Security Manager, go to the **Computers** page, find the Guest VMs, and check that the Deep Security Virtual Appliance is activated and the default “Deep Security Virtual Appliance” policy is applied.

The Guest VMs should be activated and assigned security policies automatically. If a Guest VM is not activated with the expected security policy, try these steps:

- On the **Computers** page, right-click the vCenter and select **Synchronize Now**.
- If the Guest VM is still unactivated, try activating and assigning the security policies manually.

Step 4: Verify the new deployment and its security features

1. Test that the Anti-Malware module is working correctly and sending events to Deep Security Manager. See ["Test malware scans" on page 809](#).
2. Test that the network protection modules (Web Reputation, Firewall, Intrusion Prevention) are working correctly and sending events to Deep Security Manager. See ["Test Web Reputation" on page 877](#), ["Test Firewall rules before deploying them" on page 927](#), and ["Test Intrusion Prevention" on page 884](#).

Step 5: Uninstall NSX-V from Deep Security Manager

When you've verified that the Deep Security protection modules are functioning correctly, uninstall NSX-V from Deep Security Manager. For instructions, see ["Uninstall Deep Security from NSX-V manually" on page 1688](#). You're now finished the migration process.

Migration scenario 2

Follow the steps below:

- ["Before migration" below](#)
- ["Step 1: Prepare the NSX-T network and vCenter infrastructure" below](#)
- ["Step 2: Import a new appliance" below](#)
- ["Step 3: Migrate" below](#)
- ["Step 4: Verify the new deployment and its security features" on page 1663](#)
- ["Step 5: Clean up NSX-V" on page 1663](#)

Before migration

1. Review the [system requirements](#). In particular:
 - Deep Security Manager must be version 20 LTS Update 2020-11-26 or newer.
 - NSX-T must be version 3.0 or newer.
 - You should already have a Deep Security Manager with an existing vCenter connector binding to NSX-V 6.4.x.
2. Refer to Use Case 2 in [Co-existence of NSX for vSphere and NSX-T](#) in the VMware documentation to configure another cluster managed by NSX-T.
3. Refer to your VMware documentation to arrange ESXi hosts and clusters for NSX-T management.
4. If your NSX-V includes an Edge cluster, refer to [NSX Edge Networking Setup](#) in the VMware documentation and configure the Edge cluster for Routing or Bridge mode on NSX-T.
5. Confirm network connectivity before continuing with the migration process.

Step 1: Prepare the NSX-T network and vCenter infrastructure

Follow the steps in [Prepare Fabric settings](#) and configure the cluster managed by NSX-T.

Step 2: Import a new appliance

Next, in Deep Security Manager, [import a new Deep Security Virtual Appliance](#).

Step 3: Migrate

1. Back up your Deep Security Manager database in case you need to roll back your changes.
2. In Deep Security Manager, go to the **Computers** page, right-click your vCenter connector, and select **Properties**. On the **NSX Configuration** tab, note whether the option under **Policy Synchronization** is selected. You'll need to know this later in the procedure.

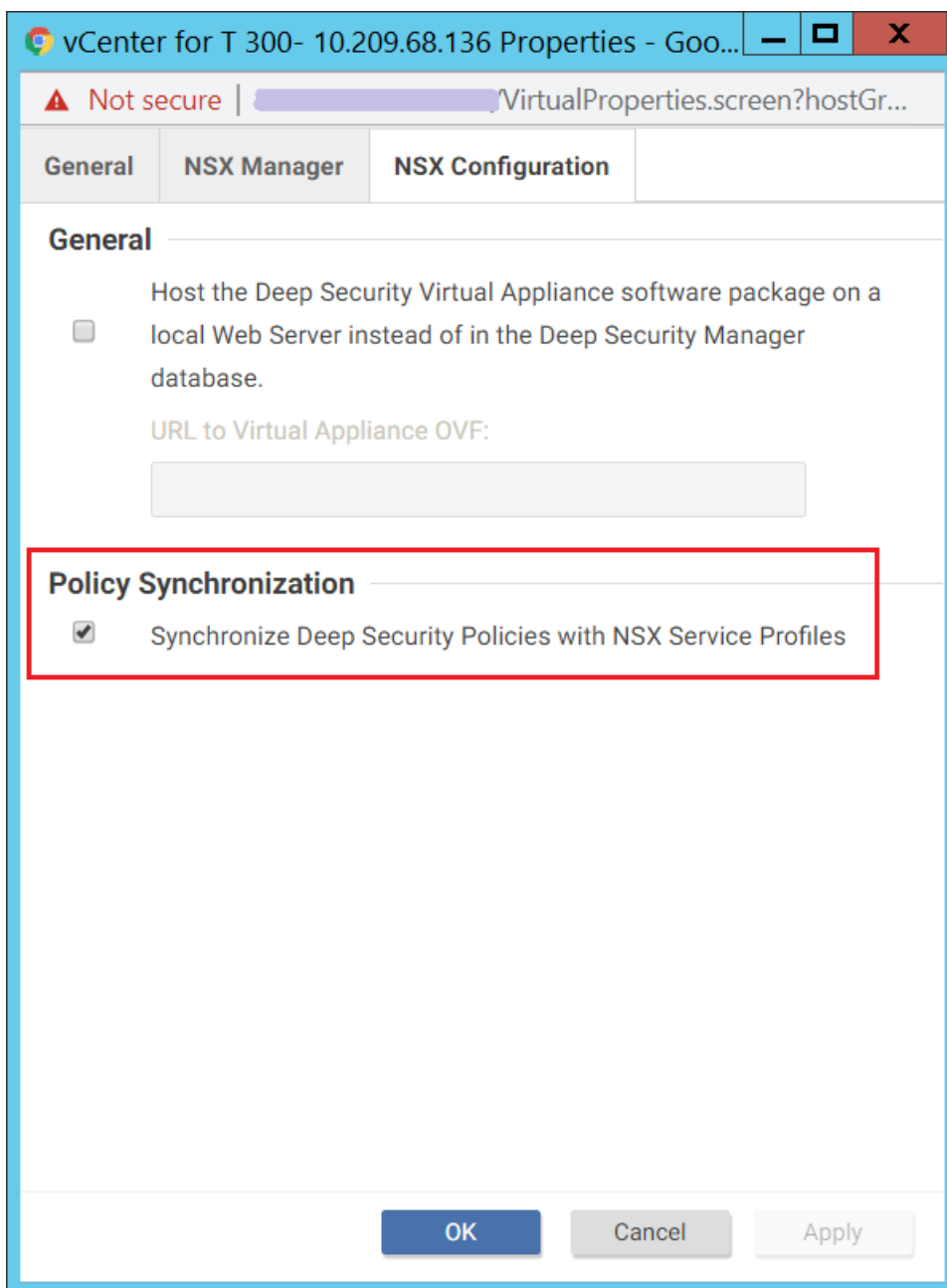

3. Remove the NSX-V binding. In Deep Security Manager, go to the **Computers** page, right-click your vCenter connector, and select **Properties**. On the **NSX Manager** tab, click **Remove NSX Manager**.

Tip: If Deep Security Manager receives system event 397 ("VMware NSX Callback Authentication Failed"), it is because the NSX settings have been removed from Deep

Security Manager, but NSX-V still has the Deep Security service. This issue will be resolved when the migration is finished and you either shut down or uninstall NSX-V.

Note: This step removes the NSX-V configurations from Deep Security Manager, but your VMs are still protected because NSX-V still has the Deep Security service. You will need to manually remove Deep Security from your NSX-V environment later (see ["Uninstall Deep Security from NSX-V manually" on page 1688](#)).

Warning: Do not change the workloads deployed on the clusters managed by NSX-V during the migration process.

4. Add the NSX-T binding. In Deep Security Manager, go to the **Computers** page, right-click your vCenter connector, and select **Properties**. On the **NSX Manager** tab:
 - a. Enter the NSX-T Manager Address and Credentials.
 - b. Click **Add/Update the Certificate** to add the NSX-T SSL certificates.
 - c. Click **Test Connection** to check that Deep Security Manager can connect to the NSX-T Manager.
 - d. Click **OK**.
5. On the **NSX Configuration** tab, check that the option under **Policy Synchronization** is set how it was in step 2.
6. Check that the Deep Security service has been registered to NSX-T. In the NSX-T Manager web console, go to **System > Service Deployments**. The "Trend Micro Deep Security" service should be registered.
7. [Deploy the Deep Security Virtual Appliance on NSX-T](#).
8. Guest VM activation and security policy assignment for NSX-T has some additional tasks, compared to NSX-V. You must:
 - a. ["Update the security group for NSX-T" on the next page](#)
 - b. ["Migrate security policies from NSX-V to NSX-T" on page 1670](#)
 - c. [Prepare for activation](#).

If you used [Method 1 or Method 2 when preparing your NSX-V environment](#), you may need to modify the "Assign Policy" or "Conditions" of existing event-based tasks to activate the Guest VM automatically.

Note: When initiating a security policy migration and creation of service profiles on NSX-T, the guest VMs under the NSX-V clusters may undergo protection loss. This is because the NSX security group binding is a part of the migration. The protection will resume after

the Guest VMs are migrated to an NSX-T cluster that has the NSX-T configurations ready.

9. Migrate the Guest VMs:
 - a. Use vMotion to move the guest VMs from the original cluster to the new one. For information, see [vMotion between VDS/VSS and NSX-T switch](#).
 - b. If you were using Network Introspection on NSX-V, after vMotion is complete and the new vCenter is on the NSX-T network, the Guest VMs need to connect at least one NIC to the Logical Switch (overlay mode) to enable the network security features on NSX-T.
10. Check the Deep Security Virtual Appliance and Guest VMs to make sure they're activated and have security policies assigned:
 - a. Activate the appliance with the default security policy "Deep Security Virtual Appliance".
 - b. The guest VMs should be activated and assigned security policies automatically. If a guest VM is not activated with the expected security policy, try these steps:
 - On the **Computers** page, right-click the vCenter and select **Synchronize Now**.
 - If the Guest VM is still unactivated, try activating and assigning the security policies manually.

Step 4: Verify the new deployment and its security features

1. Test that the Anti-Malware module is working correctly and sending events to Deep Security Manager. See ["Test malware scans" on page 809](#).
2. Test that the network protection modules (Web Reputation, Firewall, Intrusion Prevention) are working correctly and sending events to Deep Security Manager. See ["Test Web Reputation" on page 877](#), ["Test Firewall rules before deploying them" on page 927](#), and ["Test Intrusion Prevention" on page 884](#).

Step 5: Clean up NSX-V

When you've verified that the Deep Security protection modules are functioning correctly, you should clean up NSX-V, following the [instructions from VMware](#). You're now finished the migration process.

Update the security group for NSX-T

NSX-T offers [group configuration](#) with membership criteria and members categories that are different from NSX-V. You must re-create security groups on NSX-T.

NSX-V		NSX-T (Group objects on Policy mode)							
Dynamic membership criteria	Object type on include or exclude settings	Dynamic membership criteria	Members category						
<p>+ ADD</p> <p>1. Membership</p> <p>Match</p> <p>Entity</p> <ul style="list-style-type: none"> Entity Security VM Network Computer Component 	<p>Select Objects</p> <p>Object Type:</p> <p>Available Objects</p> <table border="1"> <thead> <tr> <th><input type="checkbox"/></th> <th>Name</th> </tr> </thead> <tbody> <tr> <td><input type="checkbox"/></td> <td>Account</td> </tr> <tr> <td><input type="checkbox"/></td> <td>Guest</td> </tr> </tbody> </table>	<input type="checkbox"/>	Name	<input type="checkbox"/>	Account	<input type="checkbox"/>	Guest	<p>ADD COMPUTERS</p> <p>Computers</p> <p>Members</p> <p>+ ADD</p> <p>Criteria</p> <ul style="list-style-type: none"> Virtual Security Segment IF 	<p>Members</p> <p>Membership Criteria (1)</p> <p>Filter by Object Name</p> <p>Category</p> <ul style="list-style-type: none"> Segment Port Groups (selected) Segments (selected) Segment Port VIFs (selected) Virtual Machine Physical Server <p>REFRESH</p>
<input type="checkbox"/>	Name								
<input type="checkbox"/>	Account								
<input type="checkbox"/>	Guest								

For example, this is how you would convert a security group that uses "vCenter cluster" as the membership criteria on NSX-V to NSX-T.

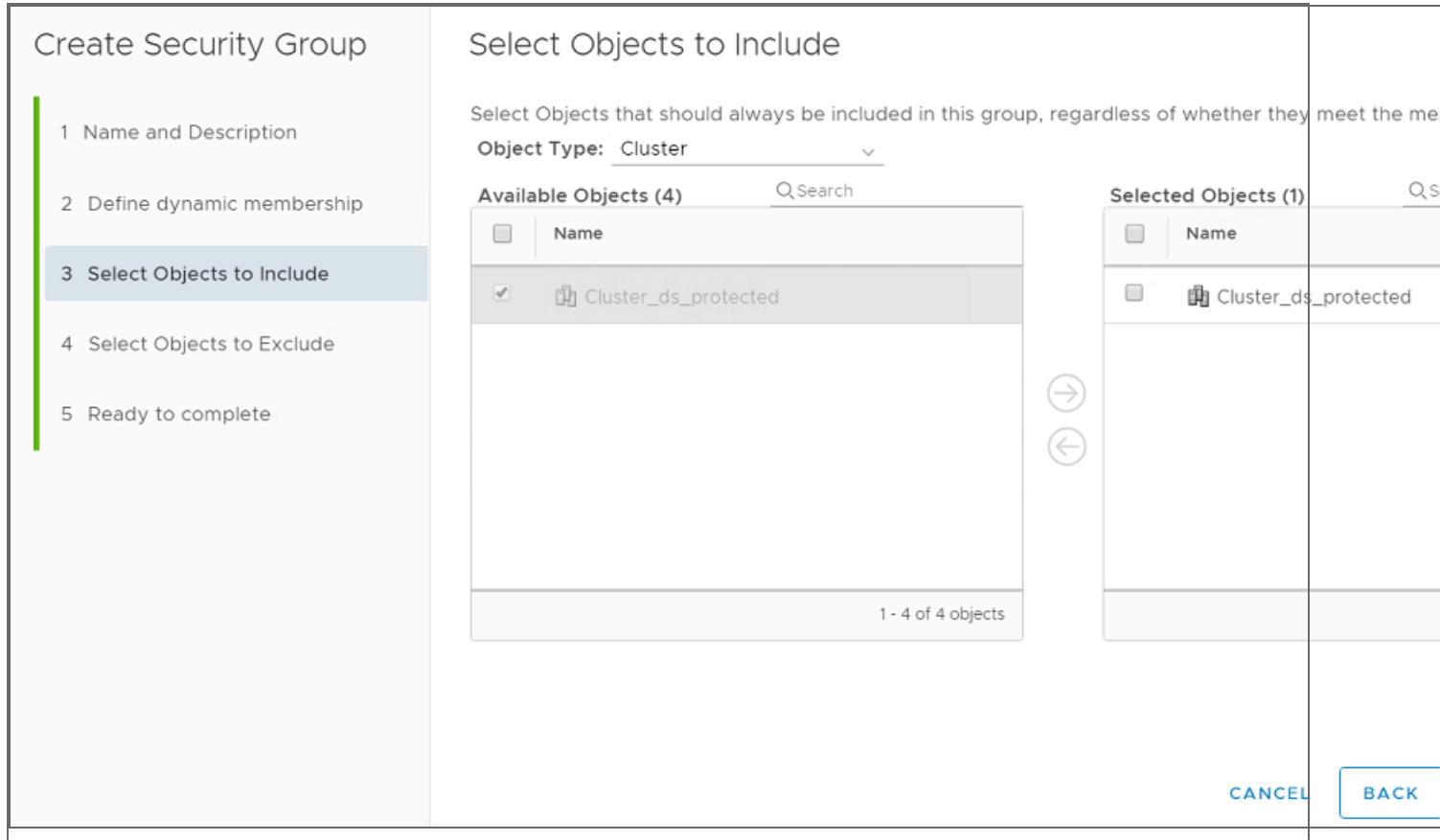

On NSX-T, the vCenter cluster object is not supported. The following 3 methods provide suggestions for how to configure a supported group on NSX-T. However, you should reference your VMware documentation for more information.

- **Method 1:** Define dynamic membership based on "VM name":
 - a. Add a group. In NSX-T, go to **Inventory > Groups** and click **ADD GROUP**.

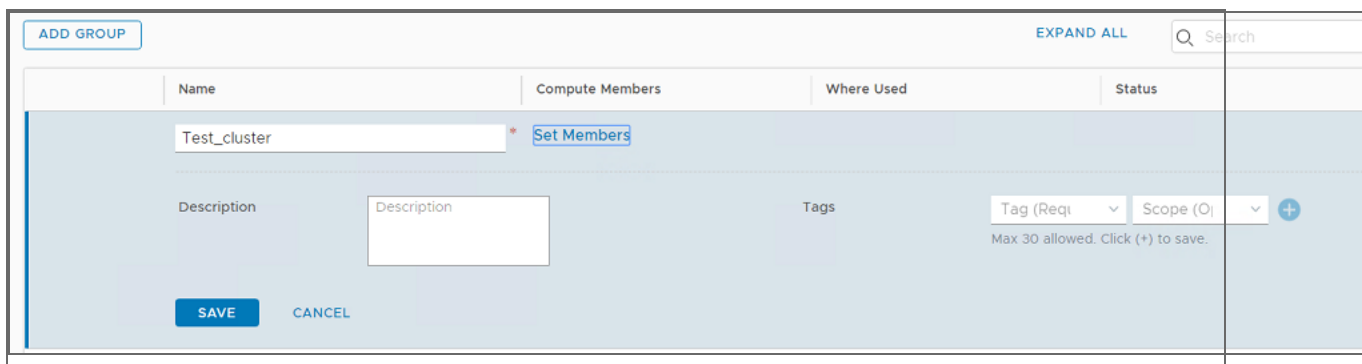

- b. Click **Set Members**, select the **Membership Criteria** tab and create one criteria for "Virtual Machine" and "Name".

Select Members | Test_cluster

Add Compute Members either by creating or by directly adding them. You can also add Identity members separately. Identity members intersect with the Compute members to define effective membership of the group.

Membership Criteria (1) Members (0) IP Addresses (0) MAC Addresses (0) AD Groups (0)

+ ADD CRITERIA Maximum: 5 Criteria

Criteria 1

Virtual Machine	Name	Contains	Windows10x86	+ -
-----------------	------	----------	--------------	-----

CANCEL APPLY

- **Method 2:** Define dynamic membership based on "VM name":
 - a. Add a group. In NSX-T, go to **Inventory > Groups** and click **ADD GROUP**.
 - b. Click **Set Members** and select the **Members** tab. In **Category**, select the VM whose

protection you want to migrate to NSX-T.

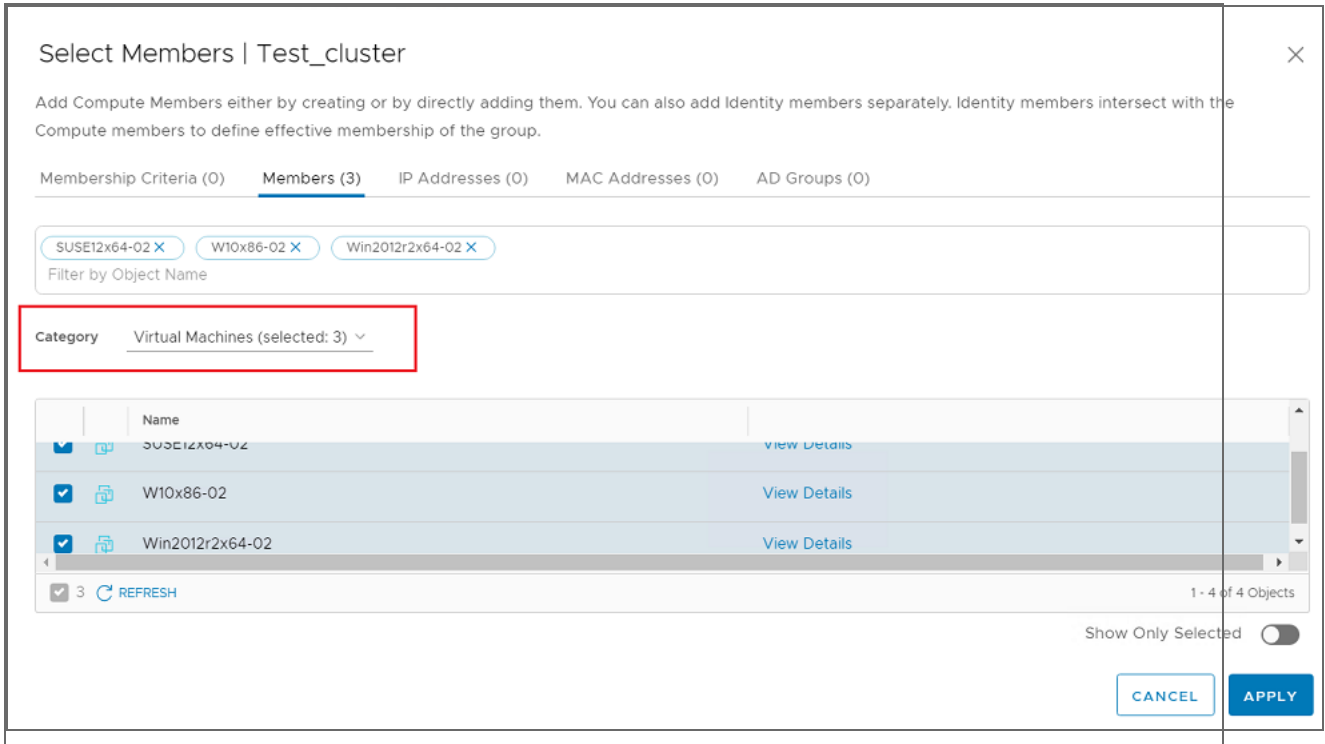

- **Method 3: Use a tag for group membership:**
 - a. In NSX-T, go to **Inventory > Tag** and create a tag.

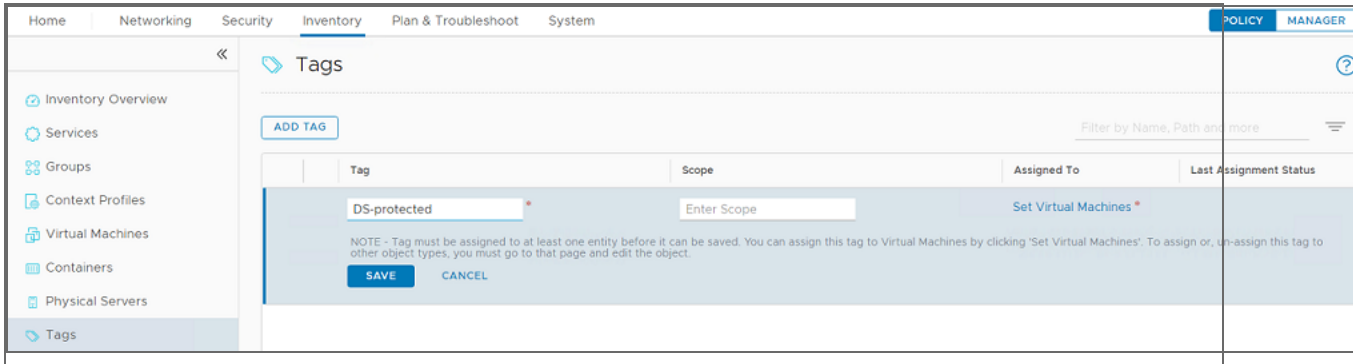

b. Click **Set Virtual Machines** and assign a VM to the tag.

Select Virtual Machines

Select Virtual Machines where this tag should be applied. To assign or un-assign this tag to other object types, you must go to that page and edit the Object.

W10x86-02 X
Win2012r2x64-02 X

Filter by Virtual Machine Name

<input type="checkbox"/>	Name	Source	Tags	Operating system	Power State	Virtual Interface
<input type="checkbox"/>	RHEL7x64-02	10.209.68.137	0	Red Hat Enterprise Linux 7 (64-bit)	● Running	VIEW DETAILS
<input type="checkbox"/>	SUSE12x64-02	10.209.68.138	0	SUSE Linux Enterprise 12 (64-bit)	● Running	VIEW DETAILS
<input checked="" type="checkbox"/>	W10x86-02	10.209.68.137	0	Microsoft Windows 10 (32-bit)	● Running	VIEW DETAILS
<input checked="" type="checkbox"/>	Win2012r2x64-02	10.209.68.138	0	Microsoft Windows Server 2012 (64-bit)	● Running	VIEW DETAILS

2 [REFRESH](#)
1 - 4 of 4 VMs

Show Only Selected

CANCEL
APPLY

c. Go to **Inventory > Groups** and click **ADD GROUP** to add a new security group.

Home | Networking | Security | **Inventory** | Plan & Troubleshoot | System
POLICY MANAGER

- [Inventory Overview](#)
- [Services](#)
- [Groups](#)
- [Context Profiles](#)
- [Virtual Machines](#)
- [Containers](#)
- [Physical Servers](#)
- [Tags](#)

Groups

ADD GROUP
EXPAND ALL

Q Search

Name	Compute Members	Where Used	Status
Test_group_vm_tag	Set Members		

Description

Tags Tag (Requ) Scope (O) +

Max 30 allowed. Click (+) to save.

SAVE
CANCEL

d. Click **Set Members** and add the "Virtual Machine" and "Tag" criteria.

Select Members | Test_group_vm_tag

Add Compute Members either by creating or by directly adding them. You can also add Identity members separately. Identity members intersect with the Compute members to define effective membership of the group.

Membership Criteria (1) Members (0) IP Addresses (0) MAC Addresses (0) AD Groups (0)

+ ADD CRITERIA Maximum: 5 Criteria

Criteria 1

Virtual Machine Tag Equals DS-protected Scope

DS-protected

This is the tag you created in previous step.

CANCEL APPLY

- e. Click **View Members**. The configured VM should be listed in virtual machines.

The screenshot shows a web interface titled "View Members | Test_group_vm_tag". It has two tabs: "Effective Members" (selected) and "Group Definition". On the left, there is a sidebar with categories: "Virtual Machines (2)", "IP Addresses (0)", "Segments (0)", "Segment Ports (0)", and "VIFs (2)". The "Virtual Machines (2)" category is selected, and a table displays two entries:

Name
W10x86-02
Win2012r2x64-02

At the bottom of the table area, there is a "REFRESH" button and a status indicator "1 - 2 of 2 Virtual Machines". A "CLOSE" button is located in the bottom right corner of the window.

Migrate security policies from NSX-V to NSX-T

On NSX-V, security policies contain both Guest Introspection and Network Introspection service configurations. You will need to re-create those configurations for NSX-T by following these steps:

1. ["Check your current NSX-V configurations" below](#)
2. ["Re-create the Guest Introspection settings for NSX-T" on page 1672](#)
3. ["Re-create the Network Introspection settings for NSX-T" on page 1673](#)

Check your current NSX-V configurations

1. On vCenter, go to **Networking and Security > Service Composer > Security Policies**. Locate the policies that were created for Deep Security services. Those are the policies that you will need to re-create for NSX-T.

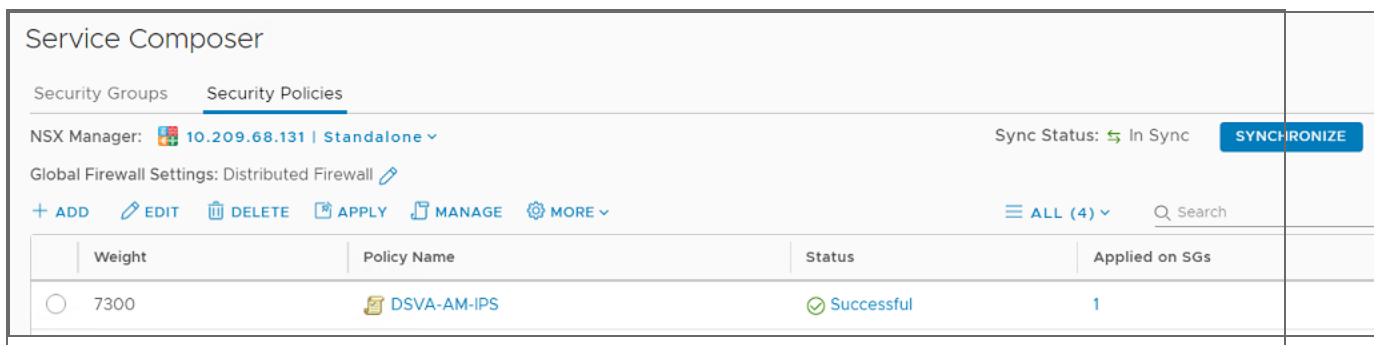

2. For each security policy:
 - a. Click the policy.
 - b. In the left pane, click **Guest Introspection Services**.

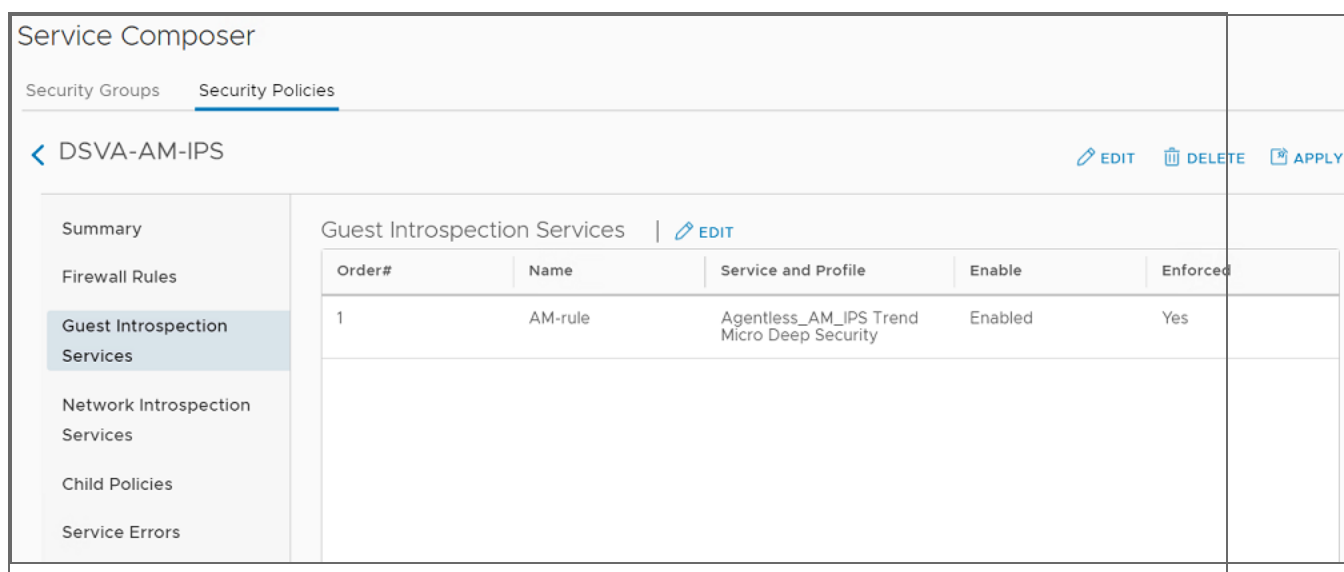

- c. Note the values in the **Service and Profile** column. You'll need that information when creating the Endpoint Protection Rules and Service Profiles for NSX-T (described in the next section).

- d. In the left pane, click **Network Introspection Services**.

The screenshot shows the Service Composer interface for a policy named "DSVA-AM-IPS". The "Security Policies" tab is active. On the left, a navigation pane highlights "Network Introspection Services". The main area displays a table of "Network Introspection Services" with the following data:

Order#	Name	Source	Destination	Service and Profile	Enable
1	In-traffic	Any	Policy's Security Groups	Agentless_AM_IPS	Enabled
2	Out-traffic	Policy's Security Groups	Any	Agentless_AM_IPS	Enabled

- e. Note the values in this table. You'll need this information when creating the **Network Introspection Settings** for NSX-T (described in a later section).

Re-create the Guest Introspection settings for NSX-T

1. In the NSX-T web console, go to **Security > Endpoint Protection Rules**.
2. Create a service profile. Choose the **Vendor Template** based on your NSX-V configuration (the value from the **Service and Profile** column of the **Guest Introspection Service** from step 2c, above).

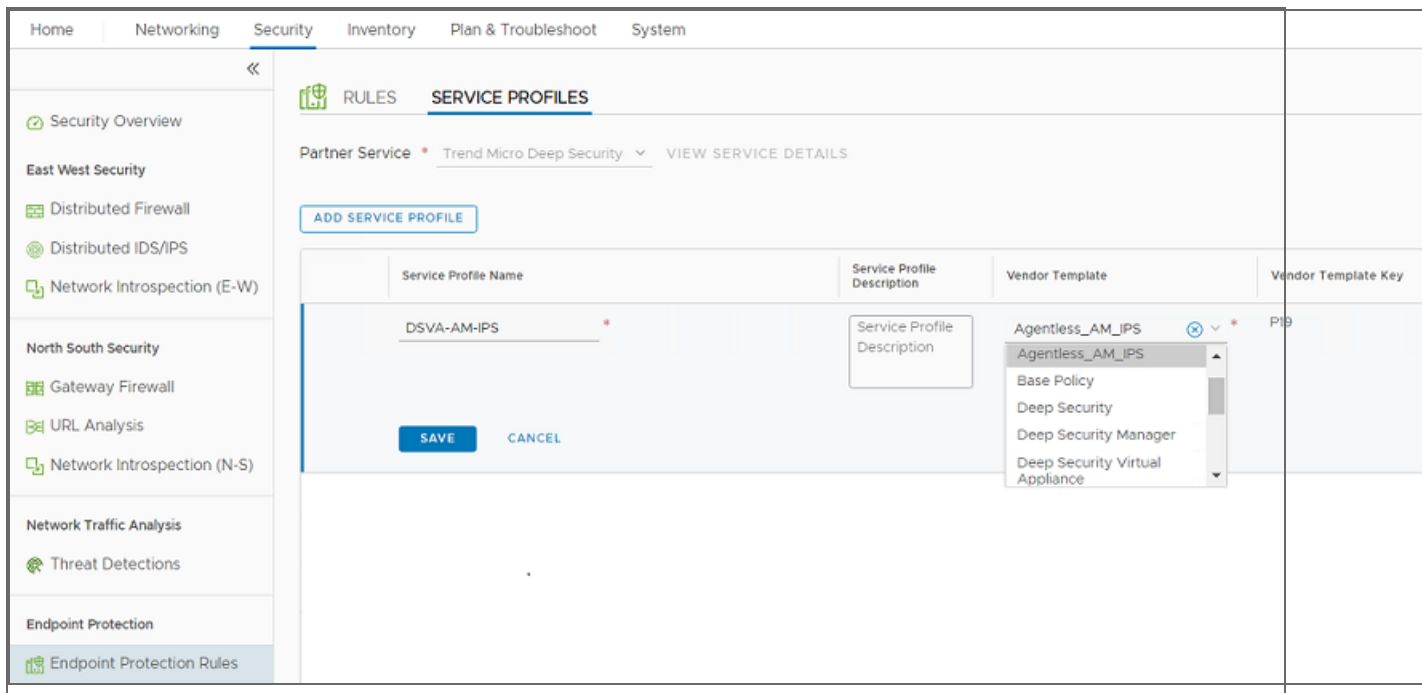

3. Create a new rule to replace each rule that was defined in the **Guest Introspection Services** for NSX-V (see step 2c, above). For each new rule, select the corresponding **Service Profile** that you created in the previous step.

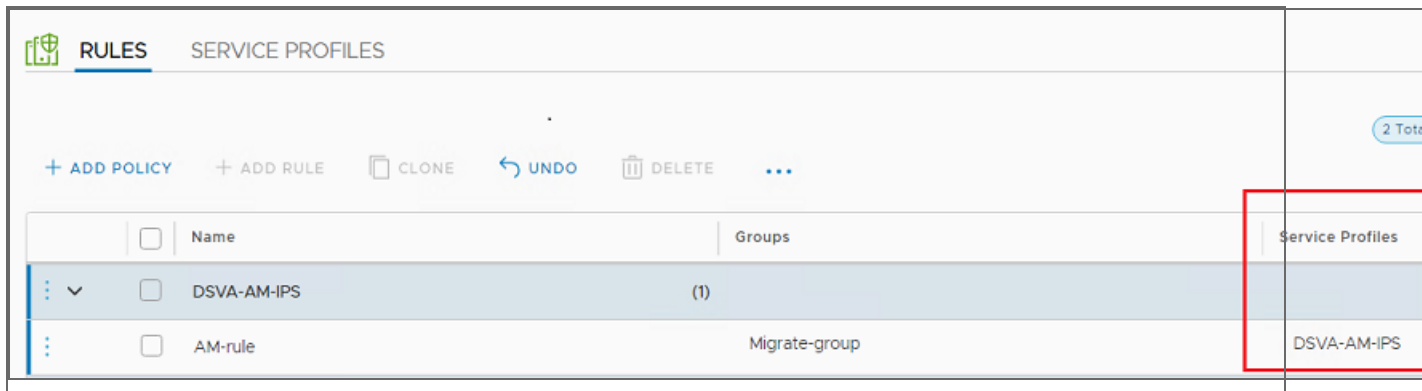

Re-create the Network Introspection settings for NSX-T

1. In the NSX-T web console, go to **Security > Network Introspection Settings > Service Profiles**.
2. Create a service profile. Choose the **Vendor Template** based on your NSX-V configuration (the value from the **Service and Profile** column of the **Network Introspection Service** from step 2e, above). Find the Vendor Template name with the same prefix name, and with the full name "same_name"_Network. In this example, it is "Agentless_AM_IPS_Network".

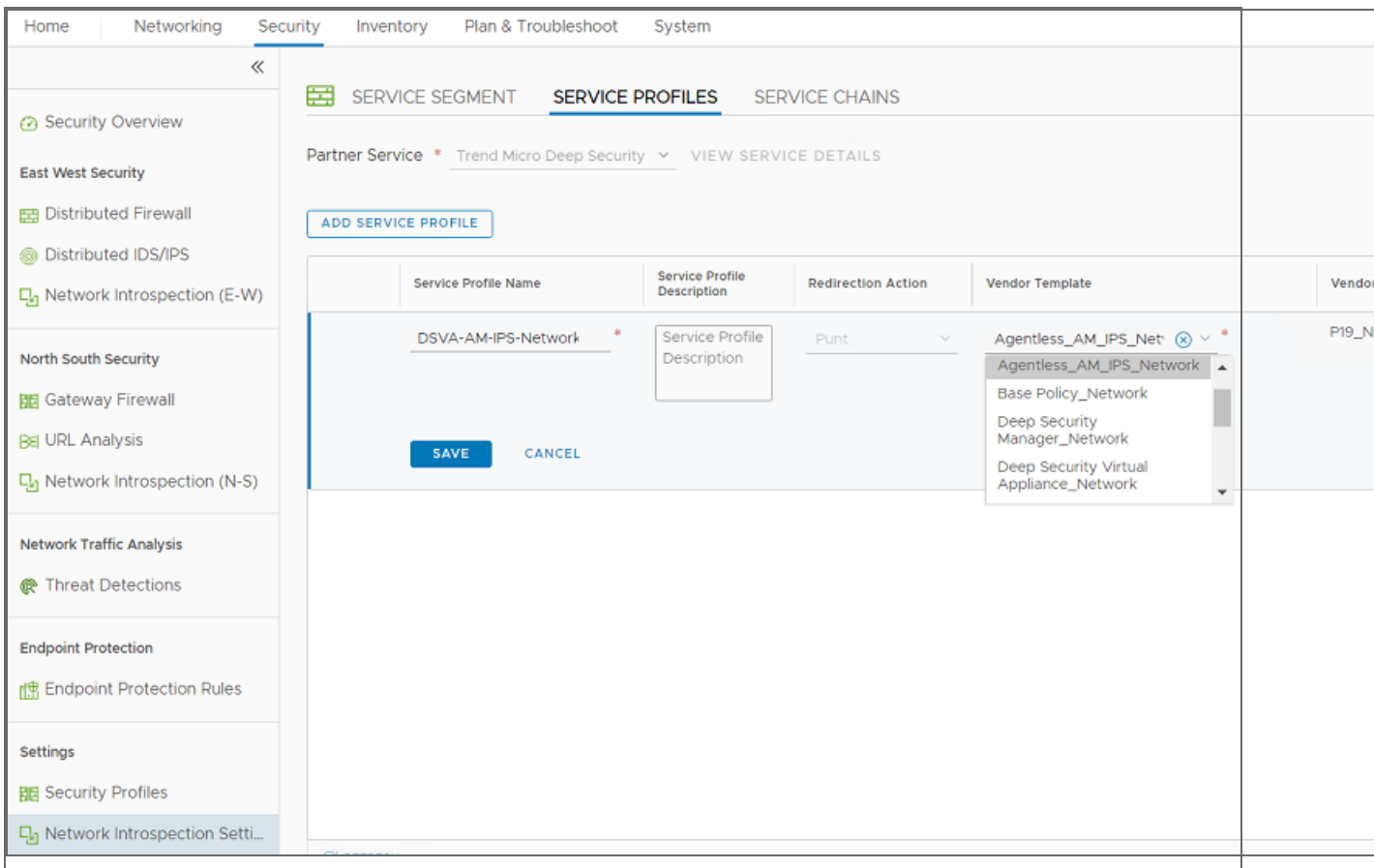

3. Go to **Service Chains** and create a service chain, selecting the service profile that you created in the previous step. In the **Service Segments** field, choose the segment you created when you deployed the Deep Security Virtual Appliance on NSX-T.

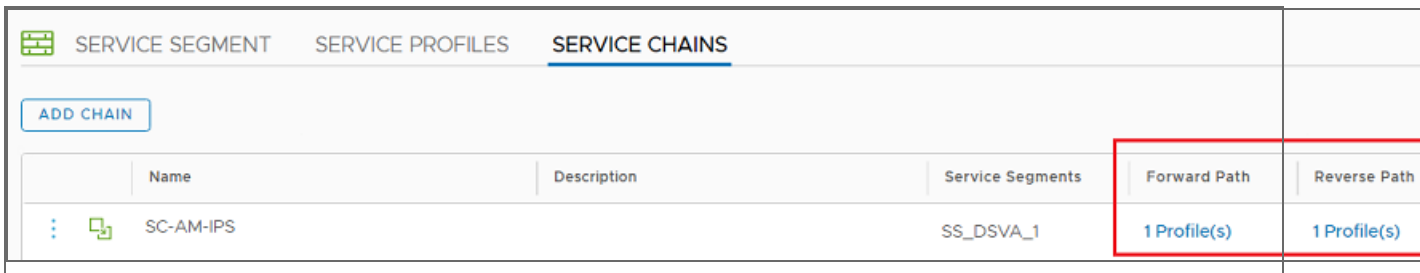

4. Go to **Security > Network Introspection (E-W)**.
5. Add one policy for each security policy that you currently have in the **Network Inspection Services** for NSX-V (see step 2e, above) and add the rules under this policy. In the **Redirect To** file, select the Service Chain that you created in step 3.

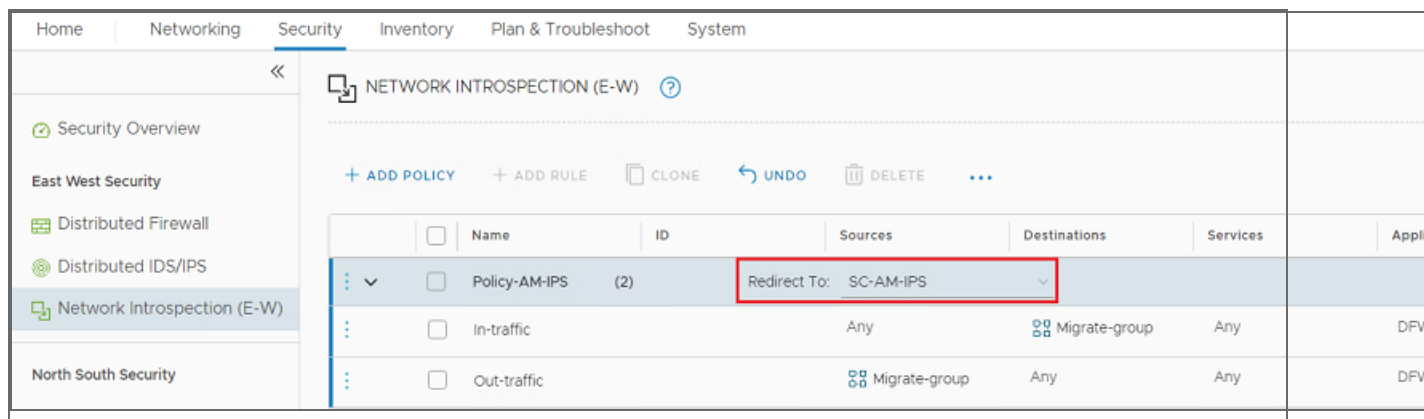

Uninstall Deep Security

Uninstall Deep Security

When you manually uninstall the activated Deep Security Agent or relay from a computer, the computer does not notify Deep Security Manager that the software has been uninstalled. On the **Computers** page in Deep Security Manager, the computer's status is still displayed as Managed (Offline) or similar, depending on the context. To avoid this, on Deep Security Manager, do one of the following:

- Deactivate the agent or relay *before* uninstalling it.
- Delete the computer from the list *after* uninstalling the agent.

Uninstall a Deep Security relay

A Deep Security relay is an agent with the relay feature enabled. To remove the relay, you must uninstall the agent software.

Uninstall a relay on Windows

Before updating or uninstalling a Deep Security Agent or relay on Windows, you need to disable agent self-protection. To do this, on the Deep Security Manager, go to **Computer editor**¹ > **Settings** > **General**. In **Agent Self Protection**, either deselect **Prevent local end-users from uninstalling, stopping, or otherwise modifying the Agent** or enter a password for local override.

¹To open the Computer editor, go to the Computers page and double-click the computer that you want to edit (or select the computer and click Details).

From the Windows Control Panel, select **Add / Remove Programs**, double-click **Trend Micro Deep Security Agent**, and then click **Remove**.

Alternatively, you can uninstall from the command line by executing the following:

```
msiexec /x <package name including extension>
```

For a silent uninstall, add `/quiet` to the preceding command.

Uninstall a relay on Linux

To completely remove the relay and any configuration files it created on a platform that uses the Red Hat package manager (RPM), such as CentOS, Amazon Linux, Oracle Linux, SUSE, or Cloud Linux, execute the following command:

```
# sudo rpm -ev ds_agent
Stopping ds_agent: [ OK ]
Unloading dsa_filter module [ OK ]
```

If iptables was enabled prior to the installation of the relay-enabled agent, it will be re-enabled when the relay-enabled agent is uninstalled.

Note: Remember to remove the relay-enabled agent from the Deep Security Manager's list of managed computers and from the relay group.

Uninstall Deep Security Agent

Uninstall an agent on Windows

Before updating or uninstalling a Deep Security Agent or relay on Windows, you must disable agent self-protection. To do this, on the Deep Security Manager, go to **Computer editor**¹ > **Settings > General**. In **Agent Self Protection**, and then either deselect **Prevent local end-users from uninstalling, stopping, or otherwise modifying the Agent** or enter a password for local override.

1. Deactivate the agent using Deep Security Manager by navigating to the **Computers** page, right-clicking the computer, and selecting **Actions > Deactivate**.

If you cannot deactivate the agent because Deep Security Manager is unable to

¹To open the Computer editor, go to the Computers page and double-click the computer that you want to edit (or select the computer and click Details).

communicate with the agent, you need to execute the following before continuing to the next step:

```
C:\Program Files\Trend Micro\Deep Security Agent>dsa_control --selfprotect 0
```

2. Open the Windows Control Panel and select **Uninstall a program**.
3. Look for Trend Micro Deep Security Agent and click **Uninstall**.

Alternatively, you can uninstall from the command line by executing the following:

```
msiexec /x <package name including extension>
```

For a silent uninstall, add `/quiet` to the preceding command.

Uninstall an agent on Linux

Before uninstalling an agent on Linux, check whether or not agent self-protection is enabled. If it is enabled, you need to disable it on the policy or computer level. For more information, see [Enable or disable agent self-protection in Linux](#).

If your version of Linux provides a graphical package management tool, you can search for the `ds_agent` package and use the tool to remove the package. Otherwise, use the command line.

To completely remove the agent and any configuration files it created on a platform that uses the Red Hat package manager (RPM), such as CentOS, Amazon Linux, Oracle Linux, SUSE, or Cloud Linux, execute the following command:

```
# sudo rpm -ev ds_agent
Stopping ds_agent: [ OK ]
Unloading dsa_filter module [ OK ]
```

If iptables was enabled prior to installing Deep Security Agent, it is re-enabled when the agent is uninstalled.

If the platform uses Debian package manager (dpkg), such as Debian and Ubuntu, execute the following command:

```
$ sudo dpkg -r ds-agent
Removing ds-agent...
Stopping ds_agent: .[OK]
```

Uninstall an agent on Solaris 10

Execute the following command:

```
pkgrm ds-agent
```

Uninstall may require a reboot.

Uninstall an agent on Solaris 11

Execute the following command:

```
pkg uninstall ds-agent
```

Uninstall may require a reboot.

Uninstall an agent on AIX

Execute the following command:

```
installp -u ds_agent
```

Uninstall an agent on Red Hat OpenShift

Execute the following command:

```
helm uninstall ds-agent
```

Uninstall Deep Security Notifier

Open the Windows Control Panel, select **Add / Remove Programs**, double-click **Trend Micro Deep Security Notifier**, and then click **Remove**.

To uninstall from the command line, execute the following command:

```
msiexec /x <package name including extension>
```

For a silent uninstall, add `/quiet` to the preceding command.

Uninstall Deep Security Manager

Uninstall the manager on Windows

From the Windows Start Menu, go to **Trend Micro > Trend Micro Deep Security Manager Uninstaller** and follow the steps to complete the uninstall.

To initiate the same Windows uninstall procedure from the command line, go to the installation folder and enter the following:

```
<installation folder>\Uninstall.exe
```

For a silent uninstall from the command line, add `-q`, as follows:

```
<installation folder>\Uninstall.exe -q
```

During a silent uninstall via the command line, the configuration files are kept so that if you reinstall, the installer repairs or upgrades the agent using existing settings.

Uninstall the manager on Linux

To uninstall via the command line, go to the installation folder and enter the following:

```
sudo ./uninstall
```

For a silent uninstall, add `-q` to the preceding command.

During a silent uninstall via the command line, the configuration files are kept by default so that if you reinstall, the installer repairs upgrades the agent using existing settings.

>If you do not keep the configuration files during the uninstall and you later decide to reinstall Deep Security Manager, perform a manual clean-up before reinstalling. To remove the Deep Security Manager installation directory, execute the following command:

```
sudo rm -rf <installation location>
```

The default installation location is `/opt/dsm`.

Uninstall Deep Security from your NSX environment

Uninstalling Deep Security from your NSX environment removes the Deep Security Virtual Appliance from NSX Data Center for vSphere (NSX-V) or NSX-T. It also uninstalls all the related history from Deep Security Manager.

Topics on this page:

- ["Uninstall Deep Security automatically" on the next page](#)
- ["Uninstall Deep Security from NSX-T 3.x manually" on page 1681](#)
- ["Uninstall Deep Security from NSX-V manually" on page 1688](#)

Uninstall Deep Security automatically

1. In Deep Security Manager, go to **Computers**.
2. In the navigation tree on the left, right-click the vCenter and select **Remove VMware vCenter**.
3. Select one of these options:
 - **Remove VMware vCenter and all subordinate computers/groups from DSM:** Removes vCenter and all records of the VMs including the Deep Security policies and rules assigned to them.
 - **Remove VMware vCenter but retain computer data and Group hierarchy:** Removes vCenter but retains its hierarchical structure and the records of the VMs including the Deep Security Policies and Rules assigned to them.
 - **Remove VMware vCenter, retain computer data, but flatten hierarchy:** Removes vCenter but retains the records of the VMs including the Deep Security policies and rules assigned to them. The hierarchical structure of the vCenter is flattened to a single group.

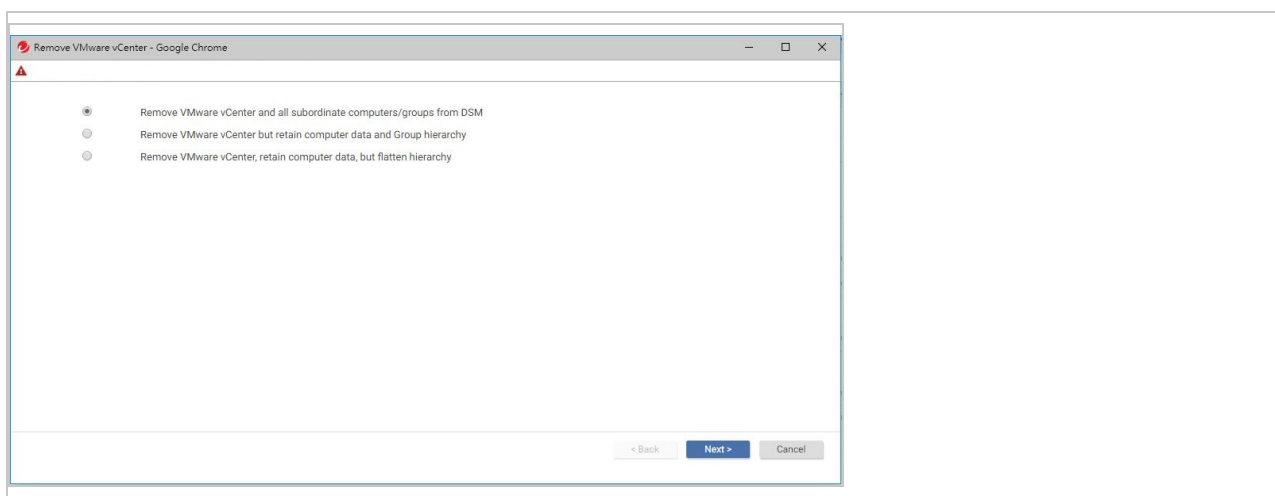

4. After selecting an option, click **Next**.

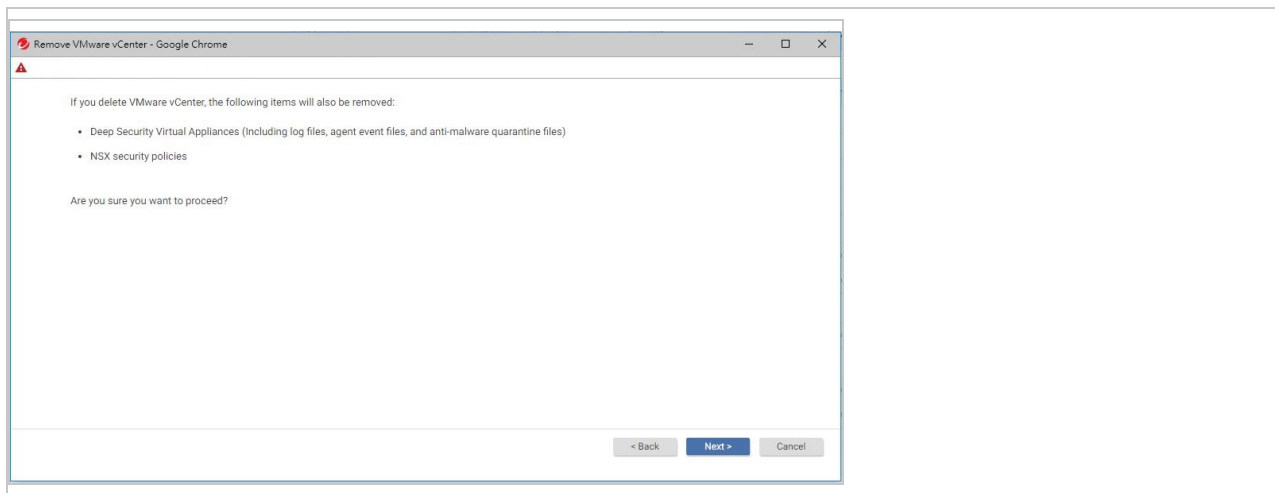

5. Click **Next** again to proceed with the removal.

Assuming you selected the first option, **Remove VMware vCenter and all subordinate computers/groups from DSM**, all Deep Security Virtual Appliances and NSX policies are removed automatically from your NSX environment.

A success message is displayed indicating `VMware vCenter was removed successfully`.

Note: If Deep Security Manager has lost connectivity with the NSX Manager, you may see an error stating `Unable to remove Deep Security from VMware`. If this error occurs, you must remove Deep Security service from NSX Manager manually. See [the next section](#) for details.

Uninstall Deep Security from NSX-T 3.x manually

Note: Make sure **POLICY** is selected at the top-right of NSX-T Manager so that you're able to see the user interface elements described in the procedures below.

First, delete the Deep Security Virtual Appliance service deployment:

1. In NSX-T Manager, go to **System > Service Deployments > DEPLOYMENT**.
2. From the **Partner Service** drop-down list, select **Trend Micro Deep Security**. A service deployment appears, if it is not already visible.

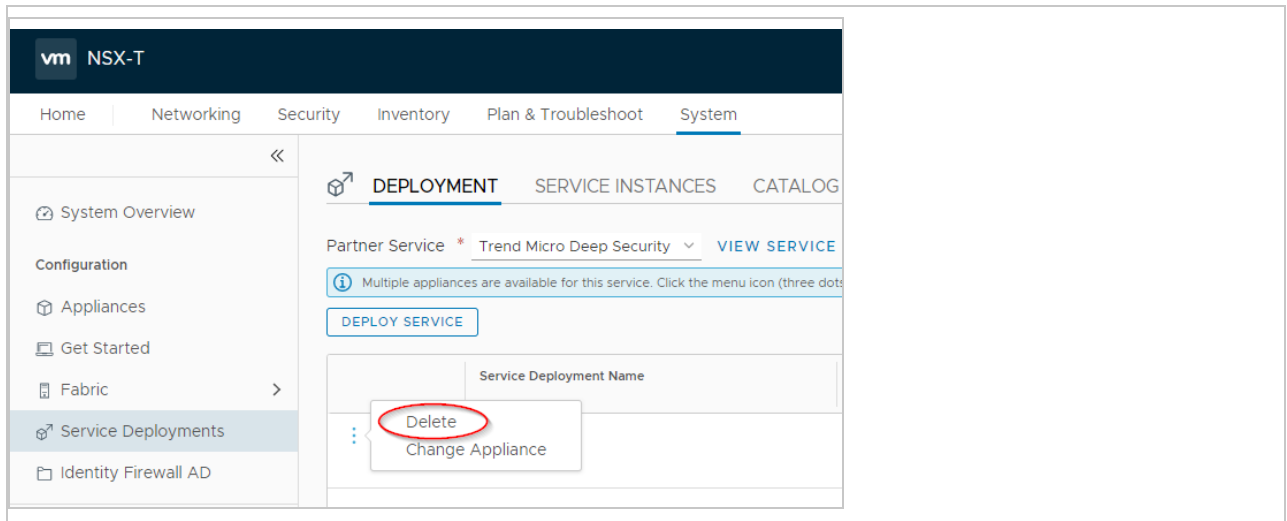

3. Click the three dots next to the service deployment name and then select **Delete**.

Next, under Endpoint Protection, delete the Deep Security Virtual Appliance policy and service profile:

1. Click **Security > Endpoint Protection > RULES**.

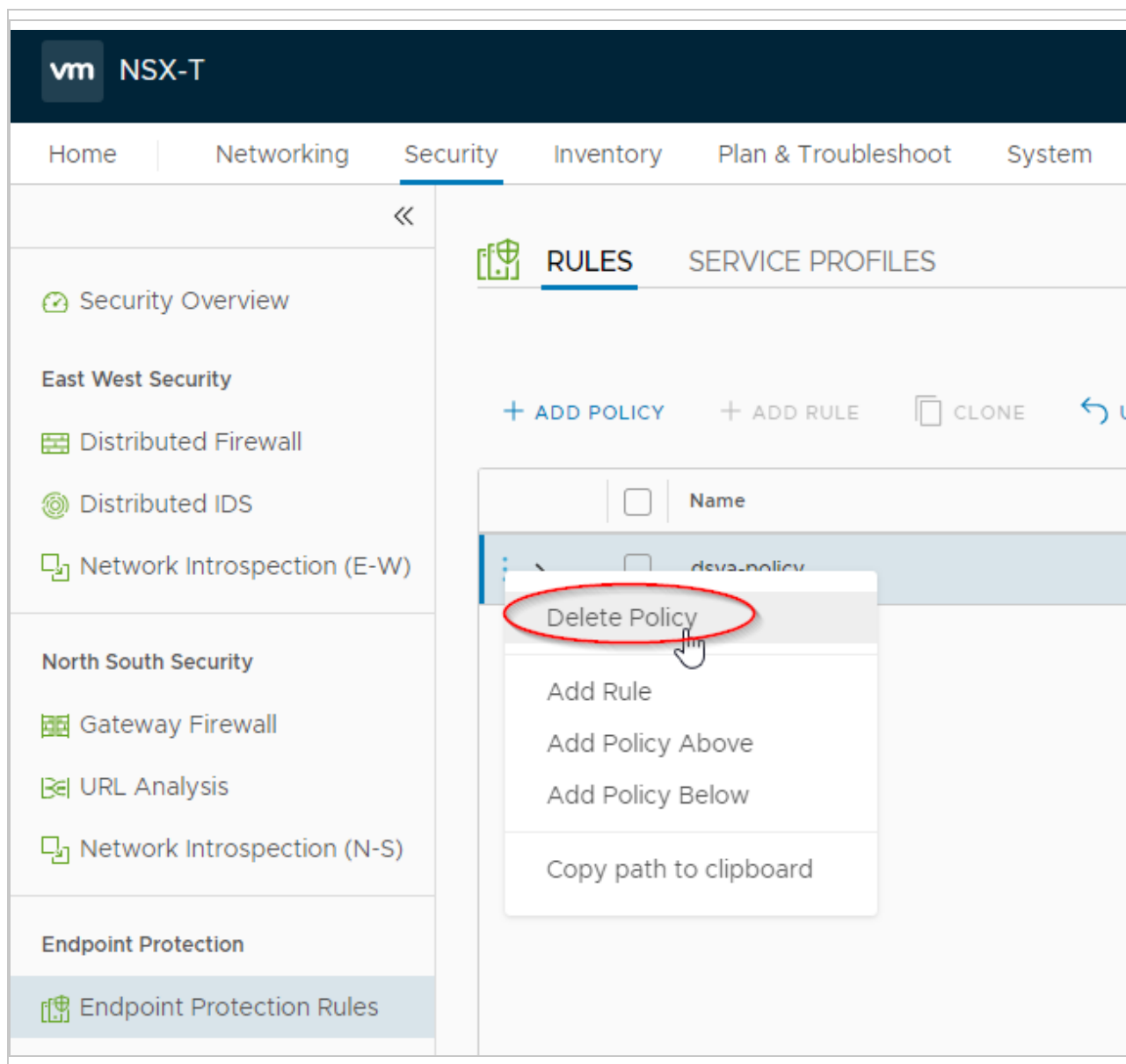

2. Click the three dots next to the Deep Security Virtual Appliance policy and click **Delete Policy**.
3. Click **Publish** to have the changes take effect. The policy and associated rule are deleted.

- click **System > Endpoint Protection > SERVICE PROFILES**.

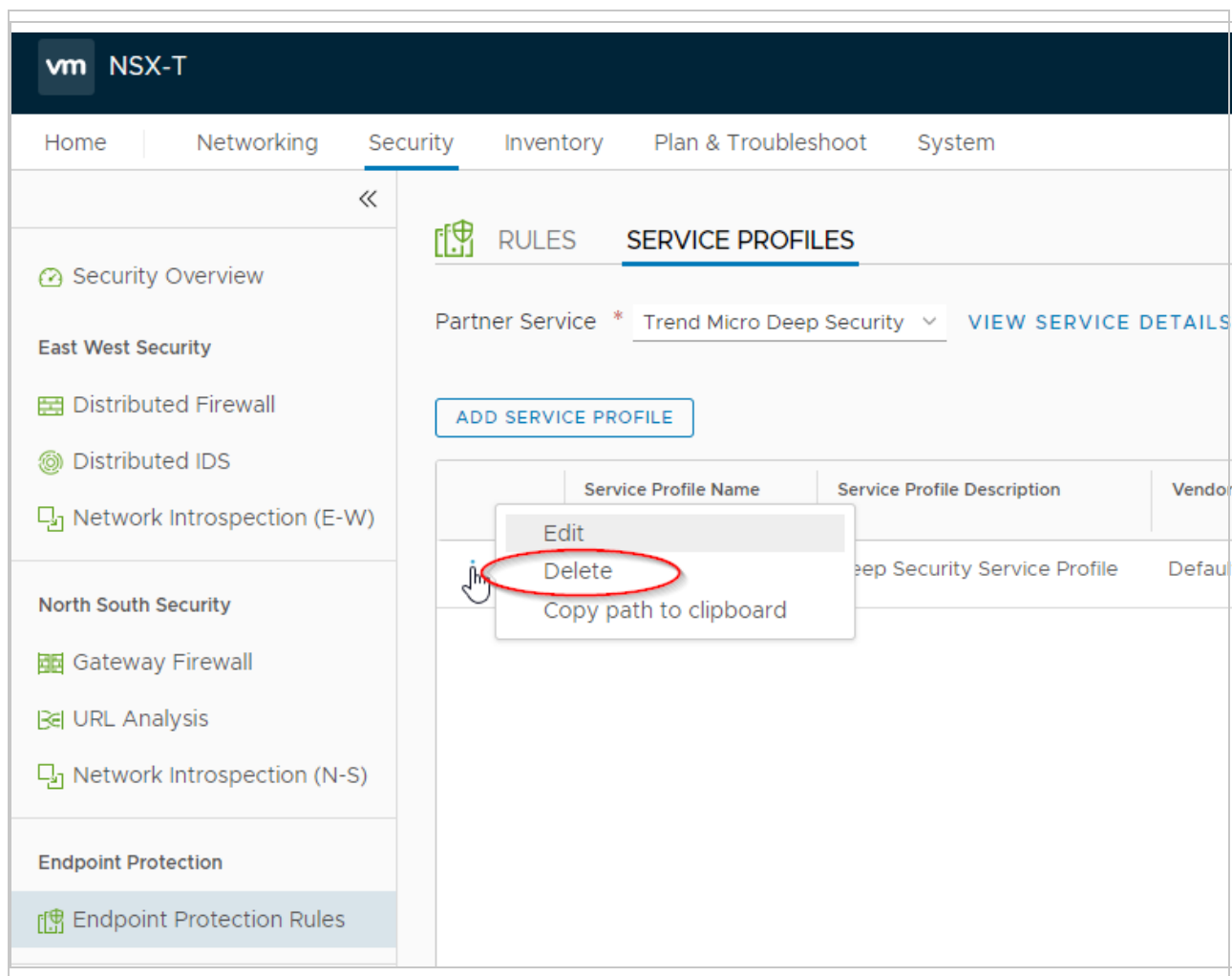

- Click the three dots next to the service profile and select **Delete**.

(Only applicable to NSX-T 3.x) Next, under Network Introspection, delete the Deep Security Virtual Appliance artifacts:

- In NSX-T Manager 3.x, click **Security**, toggle to **POLICY**, and on the left, click **Network Introspection (E-W)**.

2. Select the Deep Security Virtual Appliance policy and then click **Delete**.

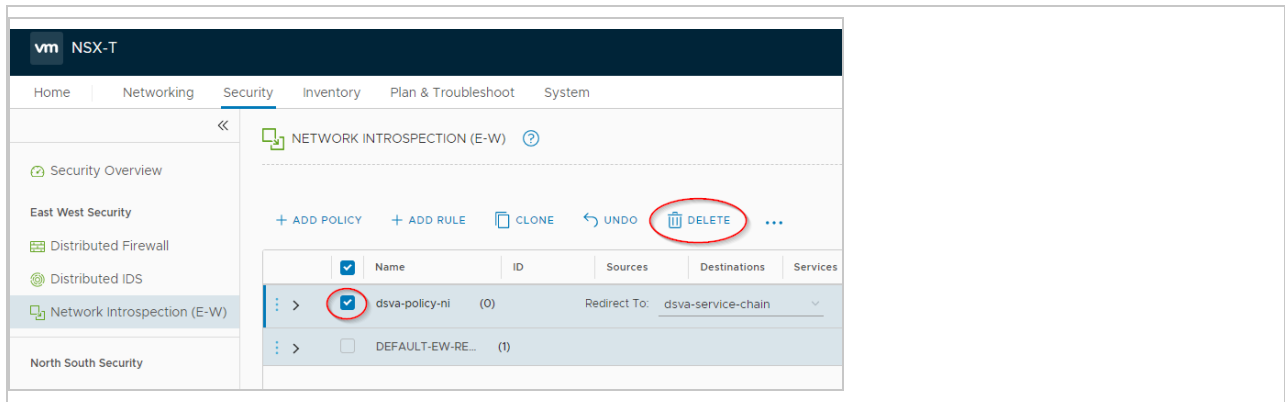

3. Click **PUBLISH** to have the changes take effect.
4. On the left, under **Settings**, click **Network Introspection Settings**.
5. In the main pane, click **SERVICE CHAINS**.
6. Click the three dots next to the Deep Security Virtual Appliance service chain and click **Delete**.

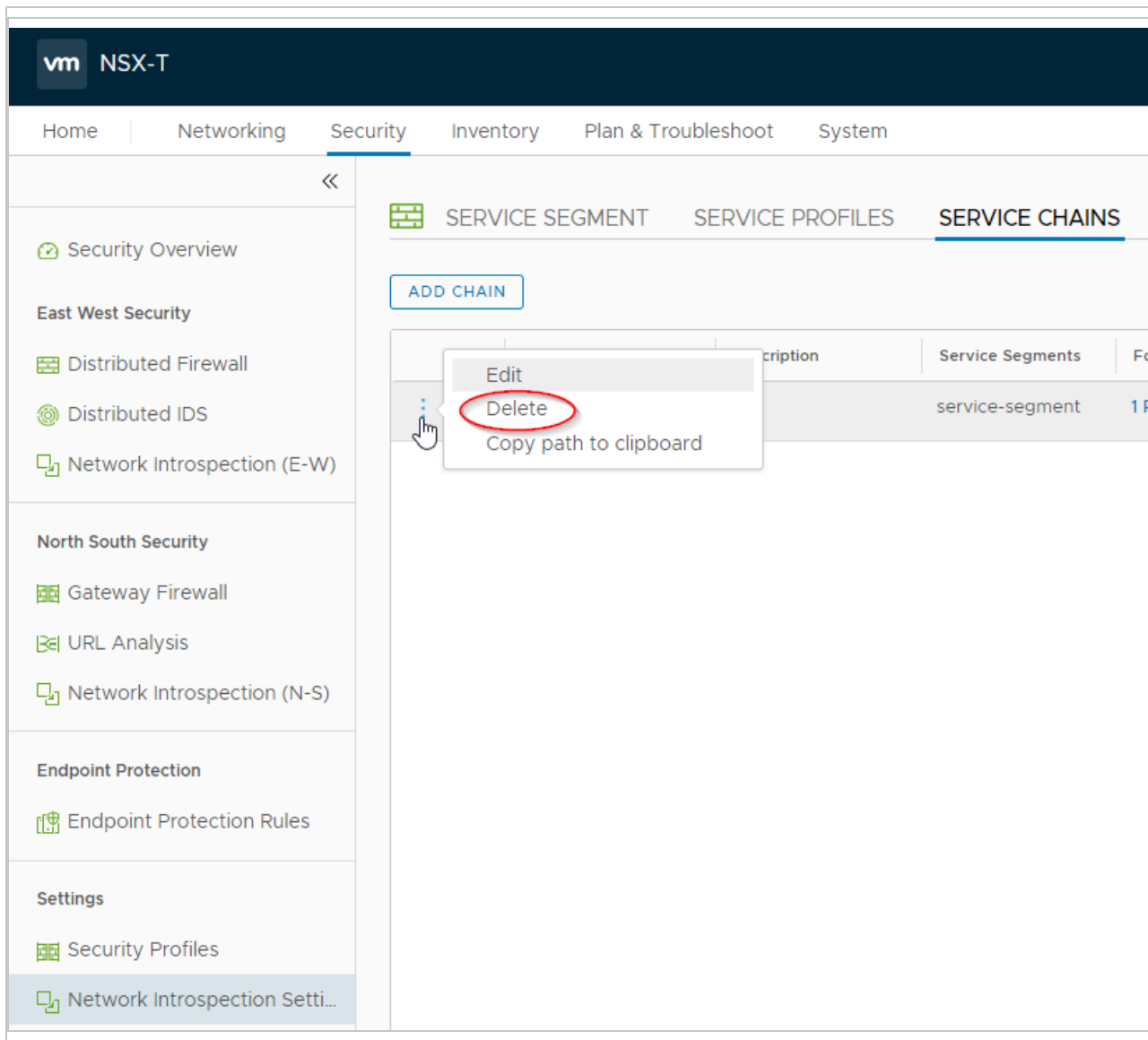

7. In the main pane, click **SERVICE PROFILES**.

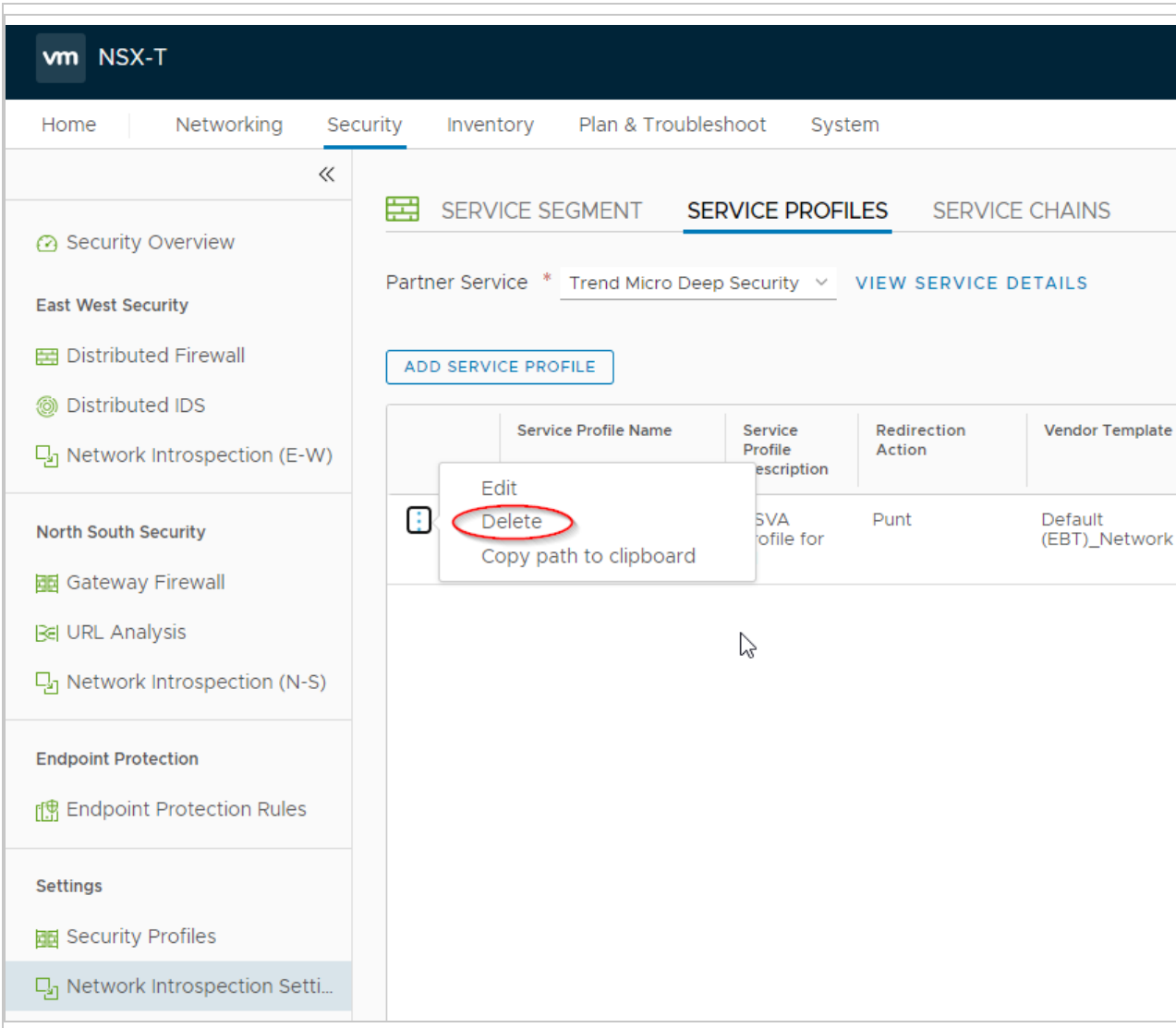

The screenshot shows the Trend Micro NSX-T Security console. The main pane is titled "SERVICE PROFILES" and displays a table of service profiles. A context menu is open over the first row, with the "Delete" option highlighted. The table has the following columns: Service Profile Name, Service Profile Description, Redirection Action, and Vendor Template. The first row contains the following data:

Service Profile Name	Service Profile Description	Redirection Action	Vendor Template
Partner Service * Trend Micro Deep Security	SVA profile for	Punt	Default (EBT)_Network

8. Click the three dots next to the Deep Security Virtual Appliance service profile and select **Delete**.

You have now deleted the Deep Security Virtual Appliance policy, service chain, and service profile under Network Introspection.

Finally, delete vCenter from Deep Security Manager:

1. In Deep Security Manager, click **Computers**.
2. Right-click your vCenter on the left and click **Remove VMware vCenter**.

A wizard appears. For a description of the options in this wizard, see "[Uninstall Deep Security automatically](#)" on page 1680.

You have now manually removed Deep Security from your NSX-T environment.

Uninstall Deep Security from NSX-V manually

This section applies to NSX-V environments only. For NSX-T instructions, see "[Uninstall Deep Security from NSX-T 3.x manually](#)" on page 1681.

If you tried to remove vCenter from Deep Security Manager using the steps in "[Uninstall Deep Security automatically](#)" on page 1680, and you saw an error stating `Unable to remove Deep Security from VMware`, it may be because Deep Security Manager lost connectivity with NSX Manager. If this error occurs, you must remove Deep Security from NSX Manager manually.

First, remove the NSX Manager from Deep Security Manager

1. In Deep Security Manager, go to **Computers**.
2. In the navigation tree on the left, right-click the vCenter and select **Properties**.
3. On the **NSX Manager** tab, click **Remove NSX Manager**.
4. Click **OK**.

Next, remove the Trend Micro service on NSX Manager

1. In the vSphere Web Client, go to **Home > Networking and Security > Service Composer > Security Policies**.

Delete the **Deep Security** security policies.

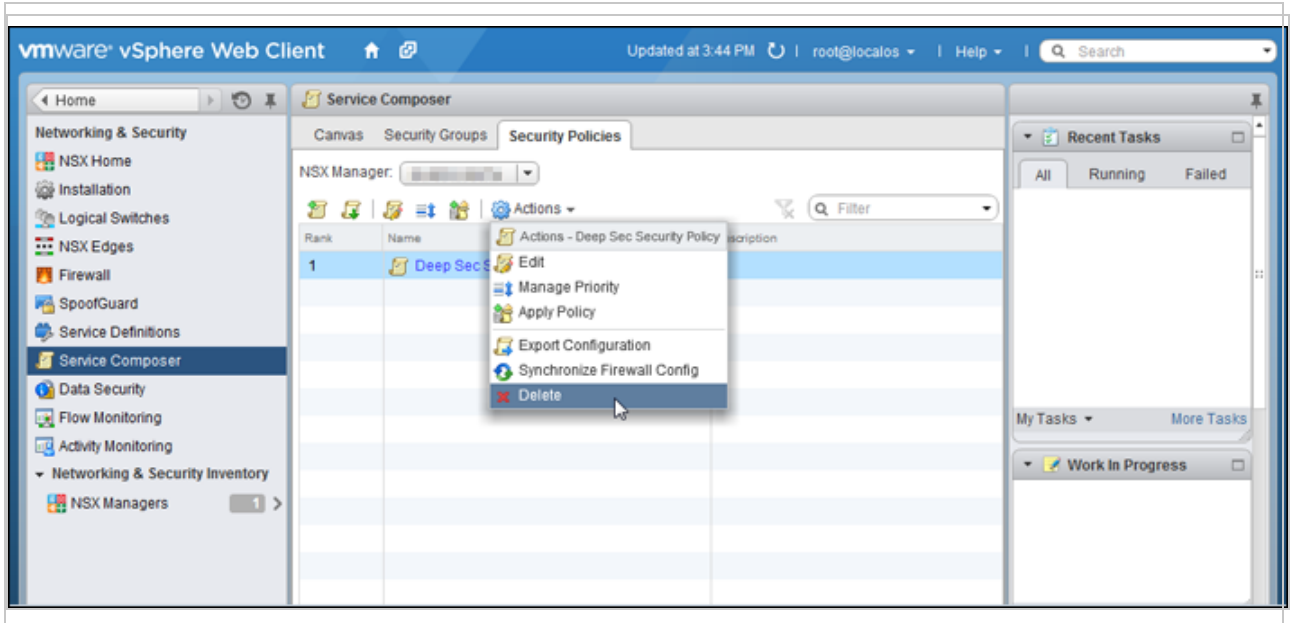

- Go to Home > Networking and Security > Installation > Service Deployments.
Delete the Trend Micro Deep Security service deployment.

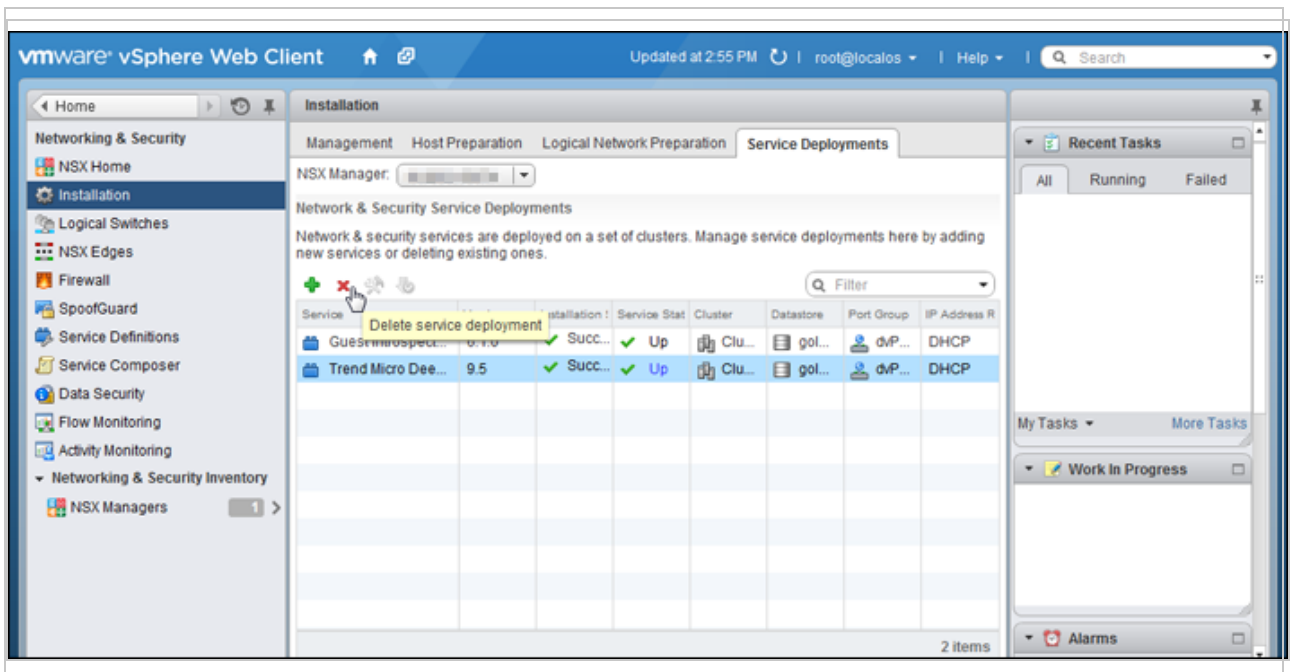

- Go to Home > Networking and Security > Service Definitions > Service Managers.

Select **Deep Security Service Manager** and click the pencil icon. Deselect **Operational State**.

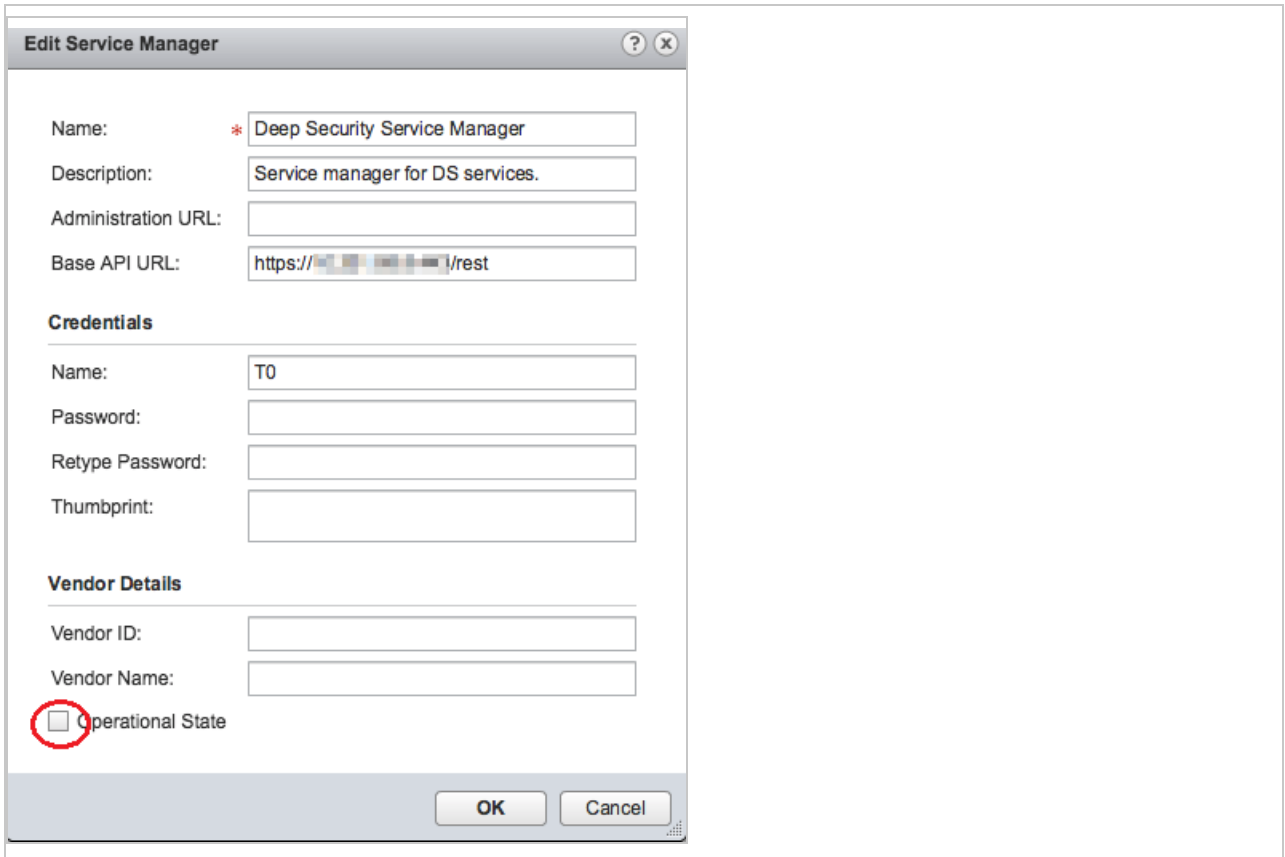
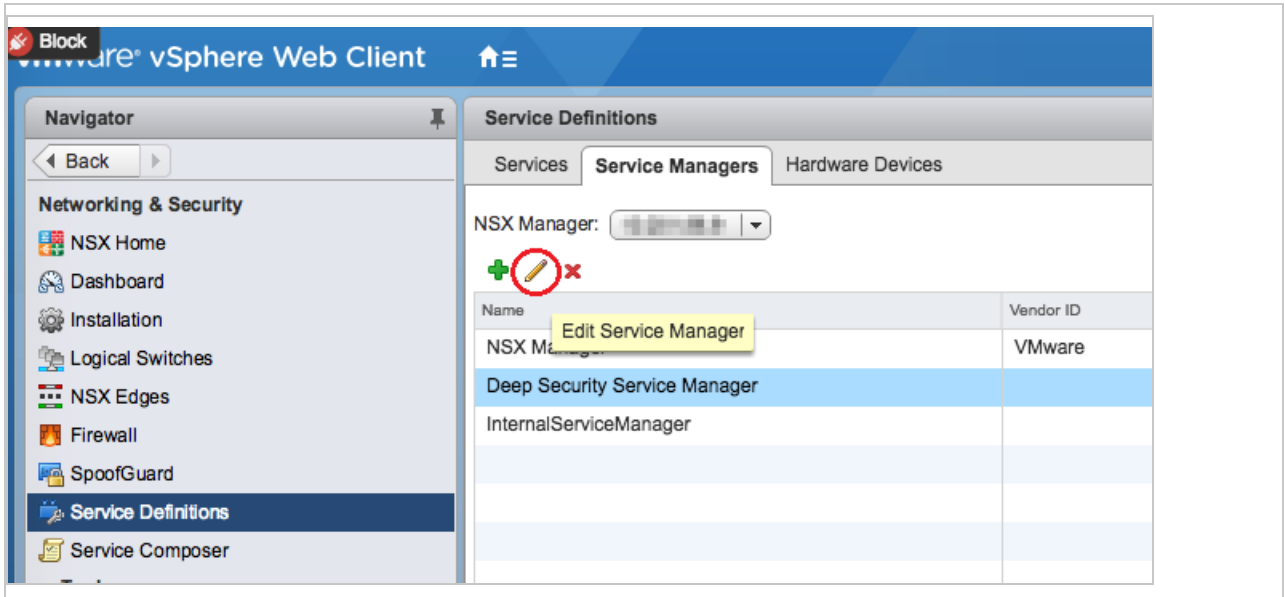

4. Go to Home > Networking and Security > Service Definitions > Services.

Click **Trend Micro Deep Security** and click the pencil icon.

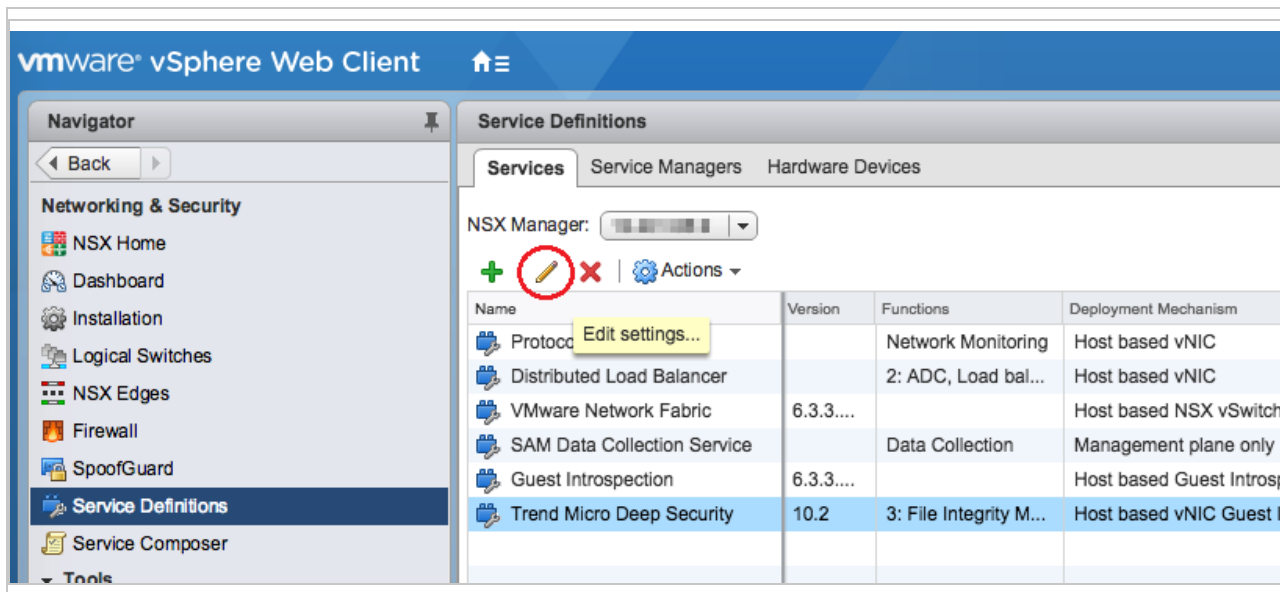

- In the left navigation pane, click **Service Instances**, and then click **Trend Micro Deep Security-GlobalInstance**, also on the left.

In the main pane, select **Default (EBT)** and click **Delete** to remove the service profile.

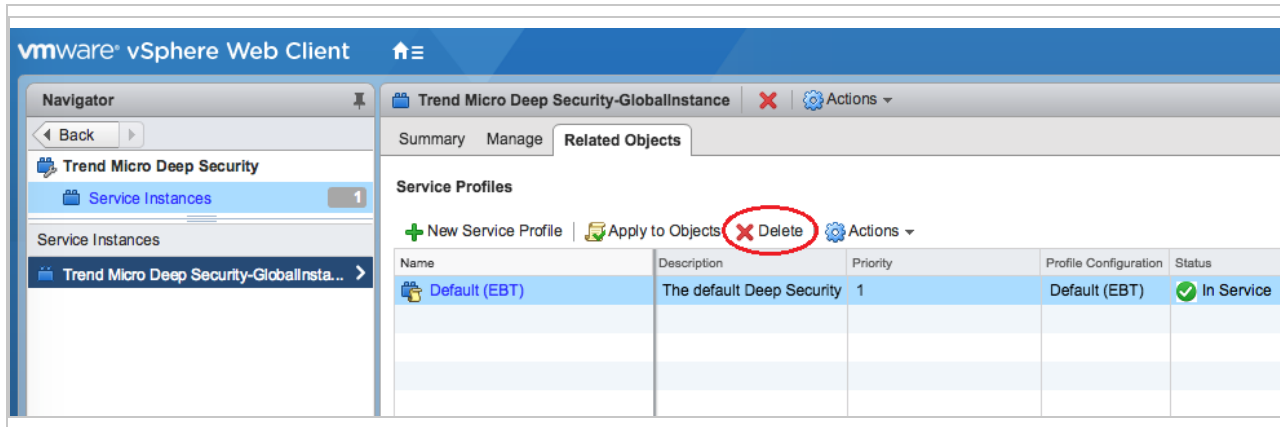

- In the left navigation pane, click **Service Instances**.

In the main pane, click **Trend Micro Deep Security-GlobalInstance** and click **Delete** to remove the service instance.

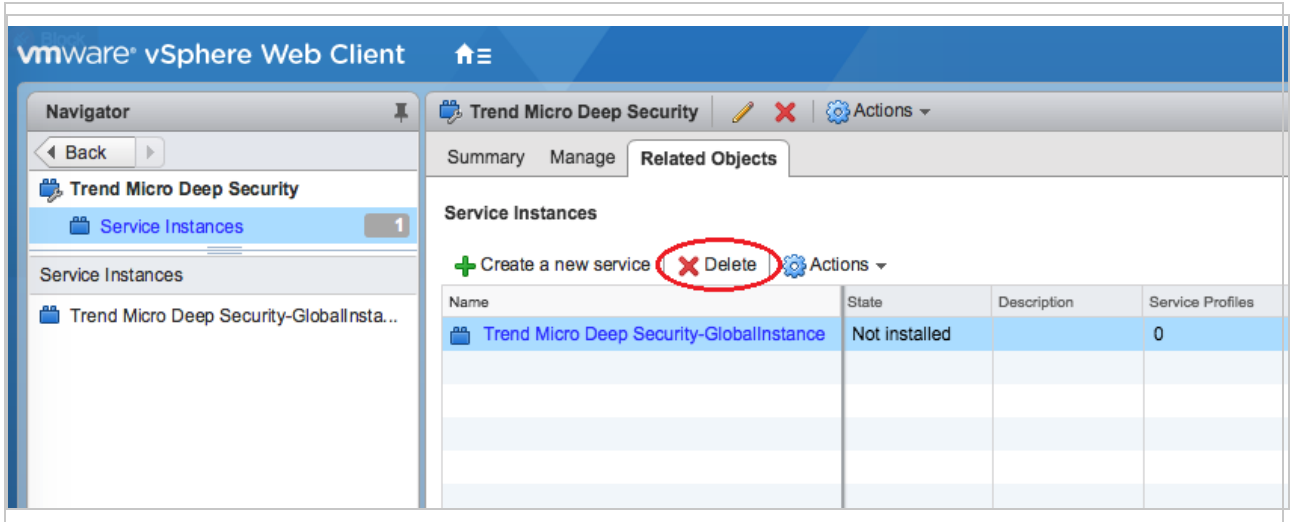

7. Select the **Trend Micro Deep Security** service definition and click the delete icon at the very top to remove it.

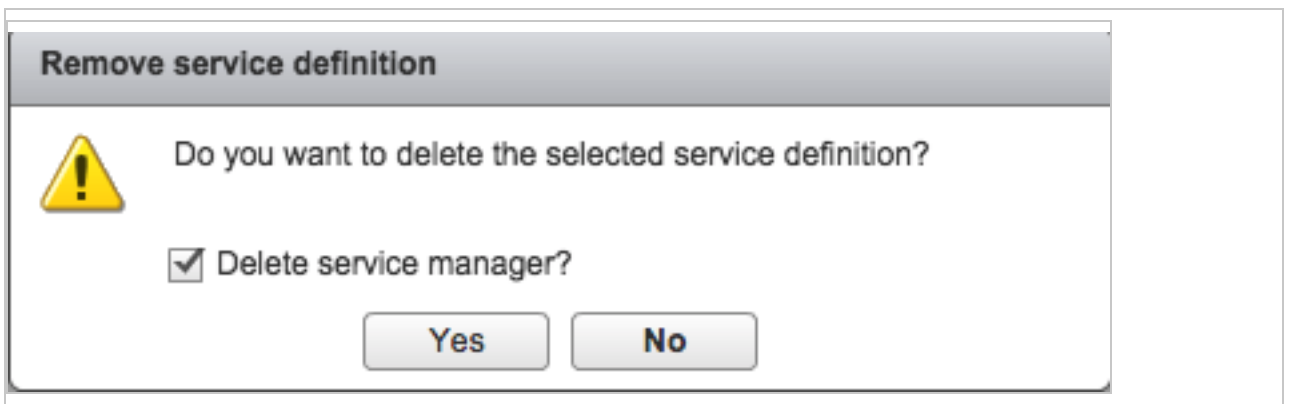
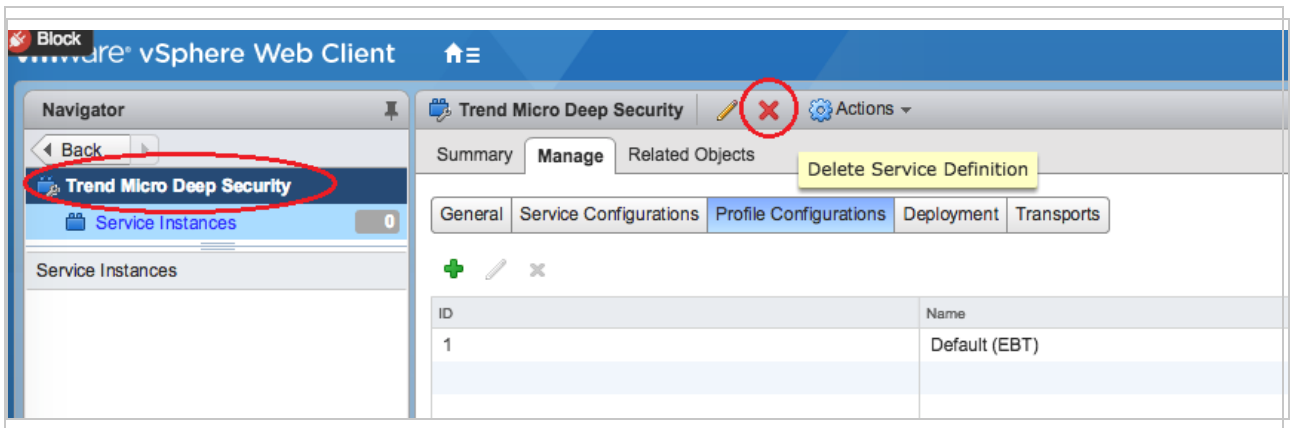

Finally, delete vCenter from Deep Security Manager:

1. In Deep Security Manager, click **Computers**.
2. Right-click your vCenter on the left and click **Remove VMware vCenter**.

A wizard appears. For a description of the options in this wizard, see "[Uninstall Deep Security automatically](#)" on page 1680.

You have now manually removed Deep Security from your NSX-V environment.

Configure Deep Security Manager memory usage

Configuring the installer's maximum memory usage

The installer is configured to use 1GB of contiguous memory by default. If the installer fails to run you can try configuring the installer to use less memory.

1. Go to the directory where the installer is located.
2. Create a new text file called "Manager-Windows-xx.x.xxxx.x64.exe.vmoptions" or "Manager-Linux-xx.x.xxxx.x64.sh.vmoptions", depending on your installation platform (where "xx.x.xxxx" is the build number of the installer).
3. Edit the file by adding the line: "-Xmx800m" (in this example, 800MB of memory will be made available to the installer.)
4. Save the file and launch the installer.

Configuring Deep Security Manager's maximum memory usage

The Deep Security Manager default setting for memory allocated to the Manager JVM process is 4GB. It is possible to change this setting.

Note:

When you install Deep Security Manager version 20.0.313 ([20 LTS Update 2021-01-18](#)) or newer, if the installer detects at least 16GB of RAM available, the default amount of memory allocated to the Manager JVM process will be 8GB.

1. Go to the Deep Security Manager install directory (the same directory as Deep Security Manager executable).

2. Create a new file. Depending on the platform, give it the following name:
 - **Windows:** "Deep Security Manager.vmoptions".
 - **Linux:** "dsm_s.vmoptions".
3. Edit the file by adding the line: "`-xmx10g` " (in this example, "10g" will make 10GB memory available to the Deep Security Manager.)
4. Save the file and restart the Deep Security Manager.
5. You can verify the new setting by going to **Administration > System Information** and in the System Details area, expand **Manager Node > Memory**. The Maximum Memory value should now indicate the new configuration setting.

Restart the Deep Security Manager

Linux

To restart the Deep Security Manager, open a CLI and run the following command:

```
sudo systemctl restart dsm_s
```

Windows

To restart the Deep Security Manager, first log in to the Windows instance on which the Deep Security Manager is running and then follow the steps below for the ["Windows desktop" below](#), the ["Command prompt" below](#) or ["PowerShell" on the next page](#):

Windows desktop

1. Open the Windows Task Manager.
2. Click the **Services** tab.
3. Right click the **Trend Micro Deep Security Manager** service, and then click **Restart**.

Command prompt

Open the command prompt (`cmd.exe`) and run the following commands:

1. `net stop "Trend Micro Deep Security Manager"`
2. `net start "Trend Micro Deep Security Manager"`

PowerShell

Open PowerShell and run the following commands:

1. `Stop-Service 'Trend Micro Deep Security Manager'`
2. `Start-Service 'Trend Micro Deep Security Manager'`

Check your license information

Note: This information does not apply to a multi-tenant configuration that inherits licensing from the parent tenant.

Check your current licenses

To see information about your Trend Micro Deep Security product licenses, go to **Administration > Licenses** in the Deep Security Manager console.

The screenshot shows the Trend Micro Deep Security console interface. The top navigation bar includes the Trend Micro logo, the text 'Deep Security', and user information 'Primary | MasterAdmin'. Below the navigation bar, the 'Administration' tab is selected. The left sidebar contains a menu with 'Licenses' highlighted. The main content area is titled 'Licenses' and features a green banner stating 'License Information last successful update on: January 4, 2021' with an 'Update Information' button. Below this is a table with the following data:

	Status	Type	Expires	
Anti-Malware and Web Reputation	● Activated	Full	June 16, 2022	View Details...
Firewall and Intrusion Prevention	● Activated	Full	June 16, 2022	View Details...
Integrity Monitoring and Application Control	● Activated	Full	June 16, 2022	View Details...
Log Inspection	● Activated	Full	June 16, 2022	View Details...
Deep Security Scanner	● Activated	Full	June 16, 2022	View Details...
Multi-Tenant	● Activated	Full	June 16, 2022	View Details...

At the bottom of the table, there is a text input field labeled 'Enter New Activation Code...'.

Deep Security consists of six module packages:

- Anti-Malware and Web Reputation
- Firewall and Intrusion Prevention
- Integrity Monitoring and Application Control
- Log Inspection

- Deep Security Scanner
- Multi-Tenant

Each module package can be licensed fully or for a trial basis.

See details about a license

On the Licenses page, click the **View Details** button next to an individual package's license to display additional information:

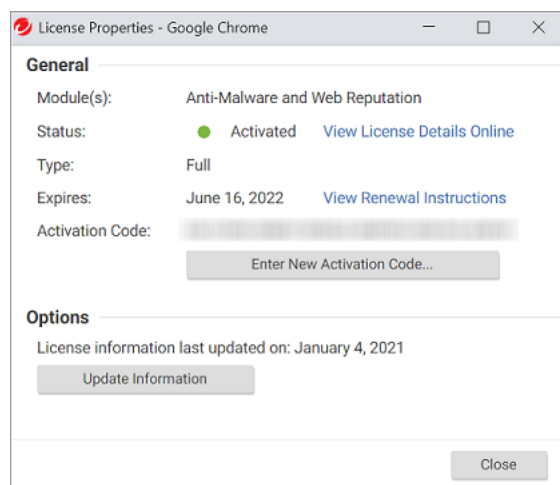

If you need more information, including the number of seats included with the license, click **View License Details Online** to go to the Trend Micro Customer Licensing Portal. The **View Renewal Instructions** link also goes to the Customer Licensing Portal.

Alerts are raised if any module is about to expire or has expired. When a license expires, existing functionality persists but updates are no longer delivered

Add or upgrade a license

To add or upgrade a license, contact Trend Micro.

If Trend Micro has provided you with a new activation code, click **Enter New Activation Code** and enter it in the window that's displayed:

To obtain the Activation Code, please [register online](#) using the Registration Key.

Protection Modules

Single Activation Code for multiple Protection Modules

All Protection Modules - - - - - -

Separate Activation Codes for each Protection Module

Anti-Malware and Web Reputation - - - - - -

Integrity Monitoring and Application Control - - - - - -

Log Inspection - - - - - -

Firewall and Intrusion Prevention - - - - - -

Additional Features

Multi-Tenant - - - - - -

Deep Security Scanner - - - - - -

< Back Next > Cancel

Newly licensed features are immediately available

Migrate to Workload Security

Migrate from Deep Security to Workload Security

Deep Security administrators preparing to migrate their deployment to Trend Cloud One - Endpoint & Workload Security can use the instructions in this article as a roadmap to a successful migration.

Note: You must be on Deep Security Manager 20.0.513 (20 LTS Update 2021-10-14) or later.

In general, the order of operations for a successful migration is:

1. ["Configure Workload Security account, users, roles, and authentication" on the next page](#)
2. ["Create a role and an API key" on the next page](#)
3. ["Prepare a link to Workload Security" on page 1699](#)
4. [Migrate policies](#)
5. [Migrate common objects](#)
6. [Migrate cloud accounts](#)

7. [Migrate agents](#)
8. ["Migrate other Deep Security settings" on page 1701](#)
9. ["Configure network and communication settings" on page 1703](#)

Configure Workload Security account, users, roles, and authentication

You need a Trend Cloud One account to use the Workload Security service. Set up an account before migrating any settings, policies, or computers to the service.

SAML has two levels of support in Trend Cloud One: for Workload Security specifically, and at the common level. These instructions describe connecting Deep Security with Workload Security.

Trend Cloud One has two types of accounts: **new accounts** that were created on or after August 4, 2021 and **legacy accounts** created before that date. If you're not sure which type of account you have, see [Changes to Trend Cloud One accounts](#).

If you have a new Trend Cloud One account, there is a new Identity and Access Management system in place. Review the [Trend Cloud One Account and User Management Documentation](#) for in-depth understanding of how to correctly manage users and roles when transitioning to Workload Security.

If you have a legacy Trend Cloud One account, you will need to manually migrate user and role permissions from your Deep Security implementation to the legacy account in Workload Security. User and role configurations in legacy accounts are nearly identical to the Deep Security software implementation and replicate existing functionality.

If you are using SAML with Deep Security Manager, you will need to [configure SAML in the Workload Security console](#) and import the appropriate service provider metadata exported to the identity provider performing authentication and role mapping.

Note: Integration with Active Directory for authentication is not supported in Workload Security unless delegated through SAML via ADFS.

Create a role and an API key

Follow [the instructions](#) to create a custom role. Assign the predefined permission "Deep Security Migration" of service "Workload Security" to the role. The "Deep Security Migration" permission is preconfigured and managed by Workload Security with rights to perform migration of agents or policies. The associated rights may change in the future, as additional migration features are

implemented. After creating the role, follow [the instructions](#) to create an API key with the created role.

Note: We strongly recommend that you do not assign the "Full Access" role to the API key. This role will work, but it creates security concerns.

Prepare a link to Workload Security

Note:

The role permission **Allow management of Workload Security Link** must be assigned for users to manage Workload Security Link.

1. In upper-right corner of the Deep Security Manager console, select **Support > Migrate to Workload Security**.

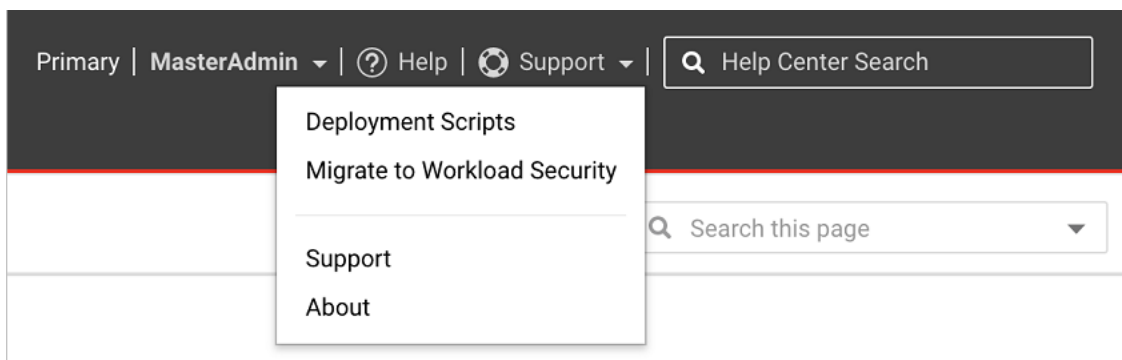

2. On the **Link to Workload Security Account** page that appears:

A screenshot of a form titled 'Link to Workload Security Account'. The form has two input fields: 'API Key:' followed by a text input field, and 'Region:' followed by a dropdown menu showing 'US-1'. At the bottom right of the form, there are two buttons: 'Save' (in blue) and 'Close' (in grey).

- a. Enter the API key that you created in the previous section.
- b. Select the region where your Workload Security account is located.

c. Select **Save**.

Warning: If you previously set up a connection between Deep Security and Workload Security and want to change the link, make sure all migration-related tasks using the previous connection are completed before changing the link. Otherwise, you may experience unexpected behavior.

Note: Each Deep Security Manager tenant allows only one Workload Security Link.

During the Workload Security Link creation, Deep Security Manager connects to Workload Security to authenticate the link and retrieve information. If the Deep Security Manager installation requires a proxy to connect to Workload Security (<https://workload.<region>.cloudone.trendmicro.com>), [configure the proxy for Workload Security](#).

3. The **Migrate to Workload Security** page appears with the **Migrate Configurations** tab selected.

Note:

The role permission **Allow migration to Workload Security** must be assigned for users to be able to process all the migration tasks.

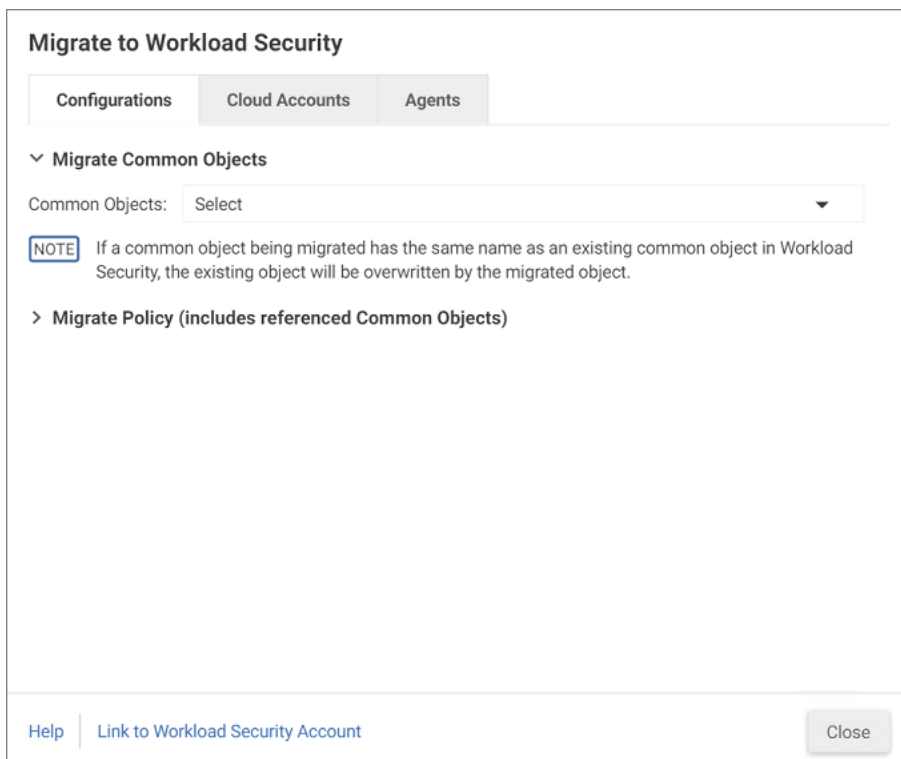

Next, [migrate your policies to Workload Security](#).

Migrate other Deep Security settings

Next, migrate these items, if you're using them in your Deep Security environment:

- ["VMware connector and data center gateway" below](#)
- ["Computer groups and smart folders" on the next page](#)
- ["Proxy configuration" on the next page](#)
- ["Event and alert logging" on the next page](#)
- ["Additional configuration" on page 1703](#)
- ["Trend Micro Vision One \(XDR\) enrollment" on page 1703](#)

VMware connector and data center gateway

Virtual machines running in a VMware environment can have agents deployed and activated to the Workload Security service the same as any other workload. If you want to connect to a VMware vCenter to retrieve a VM inventory, Workload Security needs to communicate with

vCenter. This is done through the data center gateway. For instructions on setting up the data and importing the vCenter inventory, see [Add a VMware vCenter to Workload Security](#).

Computer groups and smart folders

Computer groups and smart folders do not yet have a direct migration method. Deep Security and Workload Security have APIs for listing and creating computer groups, so migration of large numbers of groups could be automated by scripting the appropriate API calls.

Proxy configuration

Currently, there is no method for automatically migrating proxy configurations from Deep Security to Workload Security. You can manually configure proxy configurations for agent communications in Workload Security according to the instructions in [Configure proxies](#).

You do not need to configure a proxy for the manager because it is part of the Workload Security service and is maintained by Trend Micro.

Event and alert logging

A major difference between Deep Security and Workload Security is the retention of event and alert data within the manager. [Workload Security retains security events 32 days and system events 91 days](#). If you need to retain events longer, we recommend exporting events to a SIEM or log server.

Customers already using event logging may require some infrastructure change for how alerts/events are received. In a traditional on-premises deployment where Deep Security Manager sends all alerts and events via syslog to a local syslog server, that syslog server may not be directly accessible from Workload Security. Consider these alternatives:

- Create a new syslog server that is accessible from the Workload Security service, following these instructions: [Forward Workload Security events to a Syslog or SIEM server](#).
- Configure agents to send events directly to a local syslog server rather than through the manager. Note that to use TLS encryption with syslog, events must be forwarded from the Workload Security service; agents do not currently support TLS encryption of syslog events.
- Use Amazon SNS as an alternative to syslog. See [Set up Amazon SNS](#).

Additional configuration

Configuration of other items such as system settings, reports, event-based and scheduled tasks, tags, version controls, and API keys is not currently part of an automated migration feature. They can be recreated manually in Workload Security. Many of these items are configurable in both the Deep Security and Workload Security APIs and could be automated.

Note: Some system settings may not be supported or applicable when migrating from Deep Security to Workload Security, and caution is advised when automating the migration of these settings via API calls. Contact support for guidance on these settings.

Trend Micro Vision One (XDR) enrollment

Trend Micro Vision One is included with Workload Security but must be enabled via an enrollment token in the Workload Security console. You can also enable Activity Monitoring in your policies or computer settings. For details, see [Integrate Workload Security with Trend Micro Vision One](#).

Configure network and communication settings

Evaluate these items:

- ["Required ports, protocols, and URLs" below](#)
- ["Proxy configuration" below](#)
- ["Bandwidth utilization" on the next page](#)
- ["Relay configuration" on the next page](#)

Required ports, protocols, and URLs

Network communication between the Deep Security Agent and Workload Security is different from the communication between the agent and Deep Security Manager. There are also several URLs that must be specifically allowed in environments where outbound internet access is restricted. For a full list, see [Port numbers, URLs, and IP addresses](#).

Proxy configuration

For information about the configuration of proxies for agent communication to the Workload Security service, see [Configure proxies](#).

SOCKS4 and SOCKS5 proxies are not supported for agent communications. If you need to use a proxy for agent communication, implement an HTTP proxy before agents are activated to the Workload Security service.

Bandwidth utilization

When considering network planning for deployment of the Deep Security Agent, consider the overall life cycle of the agent, both for agent download and activation, as well as for ongoing operations and security pattern updates.

Existing Deep Security Agents do not need to be reinstalled, only reactivated to the Workload Security service. New deployments that are done via activation script can expect the following bandwidth usage:

- Agent download and activation: 5 MB on Linux, 25 MB on Windows
- Download of initial security update: 50 MB Linux, 102 MB Windows

Ongoing agent traffic is highly variable, depending on detection activity, policy configuration, and module usage. Expect a baseline usage for administrative traffic similar to the following guidelines:

- Security Updates (1x daily, Smart Scan on): 60 MB
- Security Updates (1x daily, Smart Scan off): 120 MB
- Heartbeat overhead: 40 KB per heartbeat. Default interval is 10 minutes, ~5.7 MB daily per agent

For more information about Smart Scan, see [Smart Protection in Workload Security](#).

Beyond baseline traffic, any detections result in additional bandwidth consumption as agents communicate with the Workload Security and Vision One services. This is difficult to predict, but expect usage in a range of 0.1 MB per hour for a low quantity of detections and up to 2-3 MB per hour for elevated detection rates, per agent.

Relay configuration

In most cases, the relays provided by the Workload Security service are sufficient. There are some scenarios where operations may be improved using relays. For details, see [How relays work](#) and [Deploy additional relays](#).

Migrate using the Deep Security and Workload Security APIs

This article and its related articles describe how to use the Deep Security Manager and Workload Security UI to perform migration. If you prefer to use the API:

- Read through this article for general requirements and tips.
- ["Create a role and an API key" on page 1698](#) as described in this article, then follow the [API document](#) to create a Workload Security Link.
- Refer to the Deep Security API documentation for information on:
 - [Migrating a policy](#)
 - [Migrating an agent](#)
 - [Migrating common objects](#)
 - [Migrating AWS connectors](#)
- To check the policy migration status, use an HTTP GET call to retrieve the status from `/policymigrationtasks/{taskID}`. For details, see [Workload Security Automation Center](#).

Items that are not currently supported via in-product migration features can generally be migrated using a combination of Deep Security and Workload Security APIs to read the pertinent setting or object from a Deep Security deployment and write it to a Workload Security account.

Some items are not available in the current API but are accessible via the legacy REST and SOAP APIs, and some features exist in Deep Security only and are not supported for migration.

Unsupported features in Workload Security:

- Deep Security multi-tenancy settings, as per the `/tenants` API. Multiple account management in Trend Cloud One supersedes traditional on-premises multi-tenancy and these settings are not applicable in Workload Security.
- Agentless protection for VMware environments

Features in the legacy REST API that are not in the current API:

- Status monitoring
- SAML configuration
- Proxy configuration, control, and assignment
- Event retrieval

Features in the SOAP API that are not in the current API:

- Proxy configuration, control, and assignment
- Event retrieval
- Actions (update agent, run scans, etc.)
- Rule configurations

Migrate policies to Workload Security

Tip: This is one part of the process for migrating from Deep Security to Workload Security. For a complete picture of the migration process, see ["Migrate from Deep Security to Workload Security" on page 1697](#).

You may want to use the same policies in Workload Security as you used in Deep Security. You can manually re-create the policies in Workload Security, or automate the policy migration using the migration tool (described in this article) or one other the [other methods for migrating policies](#).

Prerequisites

- Check that you're running Deep Security Manager 20.0.513 (20 LTS Update 2021-10-14) or later.

Note: If you don't want to upgrade to a supported Deep Security 20 version to migrate policies, [this Deep Security 12 article](#) describes how to migrate policies by exporting them to XML and then importing via API into Workload Security.

- Update to and apply the latest Deep Security Rule Updates (DSRU). In Deep Security Manager, go to **Administration > Updates > Security > Rules**

Note: If your migration results in error 303, it is mostly likely because you failed to update the DSRU.

- If you haven't done so already, complete the earlier steps described in ["Migrate from Deep Security to Workload Security" on page 1697](#), including creating a Trend Cloud One account, creating an API key, and preparing a link to Workload Security.

Limitations

- Policies containing SAP Scanner module configurations can be migrated or imported, but those settings will not be visible unless your Workload Security account is also licensed for the SAP Scanner.
- Policies containing VMware agentless configurations are not supported in Workload Security.
- Application Control settings are not migrated.
- Network-dependent objects and settings (proxy settings, syslog configurations, and so on) may not be migrated.
- Only common objects referenced by the policy are migrated. If a common object being migrated has the same name as an existing common object in Workload Security, the existing object will be overwritten by the migrated object.

Note: For information on migrating common objects, see [Migrate common objects to Workload Security](#).

Migrate policies using the migration tool

1. In upper-right corner of the Deep Security Manager console, select **Support > Migrate to Workload Security**.

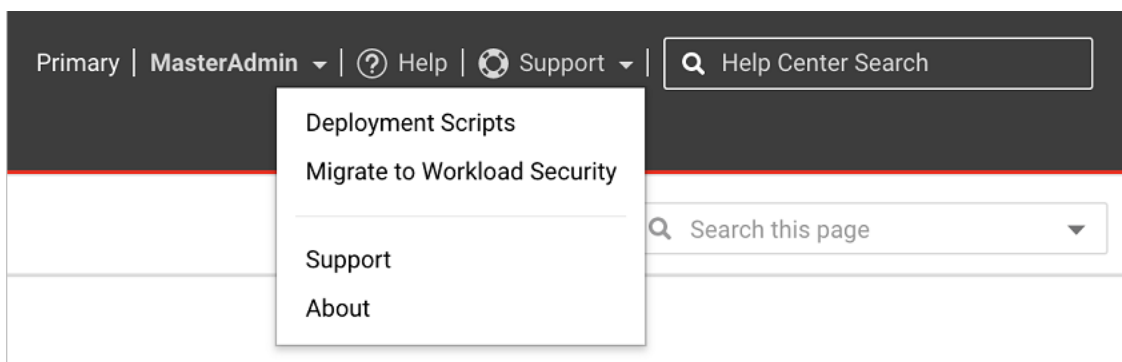

2. The **Migrate to Workload Security** page appears with the **Configurations** tab selected. Click **Migrate Policy** to expand that section.

Note: If a **Link to Workload Security Account** page appears first, see "[Prepare a link to Workload Security](#)" on page 1699 for information on how to configure the link.

3. Select **Migrate**. The migration tool targets all policies on Deep Security Manager.

4. The migration tool displays a status.

Migrate to Workload Security

Configurations
Cloud Accounts
Agents

> Migrate Common Objects

▼ Migrate Policy (includes referenced Common Objects)

Before migrating your policies, go to **Administration > Updates > Security** in Deep Security Manager and make sure the Rule Updates are up to date. Otherwise, you may get errors.

Refresh
Migrate

ITEMS	STATUS	LAST UPDATED	STARTED
All policies	Migrated	December 27, 2021 15:03:14	December 27, 2021 15:02:59

NOTE Application Control settings are not migrated. Network-dependent objects and settings (proxy settings, syslog configurations, and so on) may not be migrated.

NOTE If a common object being migrated has the same name as an existing common object in Workload Security, the existing object will be overwritten by the migrated object.

Help | [Link to Workload Security Account](#)
Close

You can also check in Workload Security by going to the **Policies** page. Any migrated policies will appear in the list, showing a timestamp and the Deep Security Manager hostname.

Trend Micro Cloud One™ > Workload Security

Dashboard
Actions
Alerts
Events & Reports
Computers
Policies
Administration

Policies

New
Delete...
Details...
Duplicate
Export

- > Base Policy
- > Base Policy (2021-01-01T00:00:00Z dsm-hostname)

These are the possible statuses:

- **Migration requested:** A policy migration task to Workload Security has been requested but the policy migration hasn't started yet.

- **Migrating:** Policies are being migrated to Workload Security. If the status stuck in "Migrating", it means the Deep Security Manager cannot get the response from Workload Security. Please check the network configuration.
- **Migrated:** Policies have been migrated successfully to Workload Security.
- **Failed:** Policies have failed to migrate to Workload Security for some reason. Check the error code:
 - Error code **303:** The policies being migrated reference one or more rules that are not available on Workload Security. Please ensure that Deep Security Manager and Workload Security are using the same Rule Update version.
 - Other error codes **less than 900:** There is a failure from Workload Security. Please contact support.
 - Error codes **greater than or equal to 900:** Deep Security Manager has a problem communicating with Workload Security. Please make sure the Workload Security Link is correctly configured, or check `server0.log` for details.

Next, [migrate your common objects to Workload Security](#).

Other methods for migrating policies

In addition to using the migration tool, you can also use these methods for migrating policies to Workload Security:

- Migrate policies directly using the Deep Security policy migration API and Workload Security Link feature, available in Deep Security Manager 20.0.463 (20 LTS Update 2021-07-22) or later. For instructions, see ["Migrate using the Deep Security and Workload Security APIs" on page 1705](#).
- Export the policy XML from Deep Security and then use the Workload Security Policy Import API. If you're using an older version of Deep Security or if a direct connection from Deep Security to Workload Security is not possible, you can export policies from Deep Security 12 or later and then import them into Workload Security using the Policy Import API. For details, see [Migrating policies to Workload Security](#) in the Deep Security 12 help.

Migrate common objects to Workload Security

Tip: This is one part of the process for migrating from Deep Security to Workload Security. For a complete picture of the migration process, see ["Migrate from Deep Security to Workload Security"](#).

[Security" on page 1697.](#)

You can use the migration tool to migrate common objects (with the exception of rules and malware configurations) to Trend Cloud One - Endpoint & Workload Security.

Prerequisites

- Check that you're running Deep Security Manager 20.0.585 (20 LTS Update 2022-01-17) or later.
- If you haven't done so already, complete the earlier steps described in "[Migrate from Deep Security to Workload Security" on page 1697](#), including creating a Trend Cloud One account, creating an API key, and preparing a link to Workload Security.

Migrate common objects using the migration tool

1. In upper-right corner of the Deep Security Manager console, select **Support > Migrate to Workload Security**.

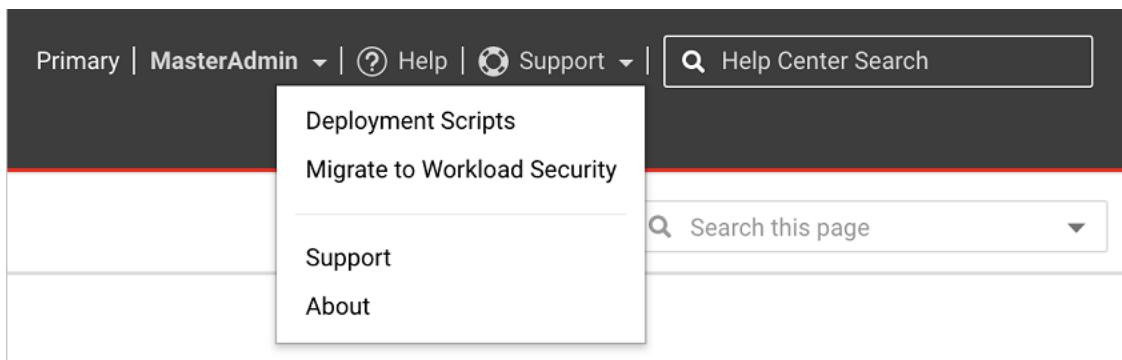

2. The **Migrate to Workload Security** page appears with the **Configurations** tab selected. Click **Migrate Common Objects** to expand that section.

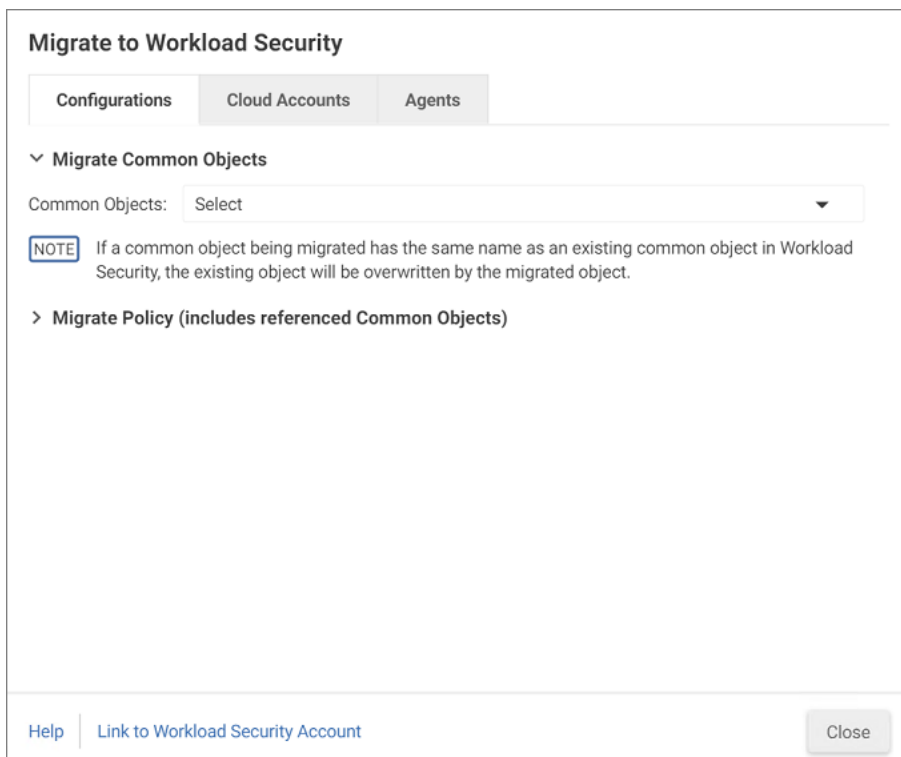

Note: If a [Link to Workload Security Account](#) page appears first, see "[Prepare a link to Workload Security](#)" on page 1699 for information on how to configure the link.

3. In the **Common Objects** list, select the type of object to migrate.

Warning: If a common object being migrated meets any of the following conditions, the existing object is overwritten by the migrated object:

- The common object has the same name as an existing common object in Workload Security, or
- The common object is a default object created by Trend Micro, whether it has the same name as an existing common object in Workload Security or not

4. A list of all common objects of the selected type appears. Select the common objects that you want to migrate and then click **Migrate Selected**.

Migrate to Workload Security

Configurations | Cloud Accounts | Agents

▼ Migrate Common Objects

Common Objects: Directory Lists

Q Name Refresh Migrate Selected

<input type="checkbox"/>	NAME ▼	STATUS	LAST UPDATED
<input type="checkbox"/>	Directory Exclusions (Windows)		
<input type="checkbox"/>	New Directory List		
<input checked="" type="checkbox"/>	New Directory List_2		
<input checked="" type="checkbox"/>	New Directory List_3		

NOTE If a common object being migrated has the same name as an existing common object in Workload Security, the existing object will be overwritten by the migrated object.

> Migrate Policy (includes referenced Common Objects)

Help | [Link to Workload Security Account](#) Close

5. The migration begins. Click the **Refresh** button to check the migration status. Possible statuses are:
- **Requested:** Common object migration to Workload Security has been requested but the migration hasn't started yet.
 - **Migrating:** Common objects are being migrated to Workload Security. If the status stuck in "Migrating", it means the Deep Security Manager cannot get the response from Workload Security. Please check the network configuration.
 - **Migrated:** Common objects have been migrated successfully to Workload Security.
 - **Failed:** Common objects have failed to migrate to Workload Security for some reason. Check the error code:
 - Error code **300**: Selected common objects do not exist.
 - Error codes **greater than or equal to 900**: Deep Security Manager has a problem communicating with Workload Security. Please make sure the Workload Security Link is correctly configured, or check `server0.log` for details.

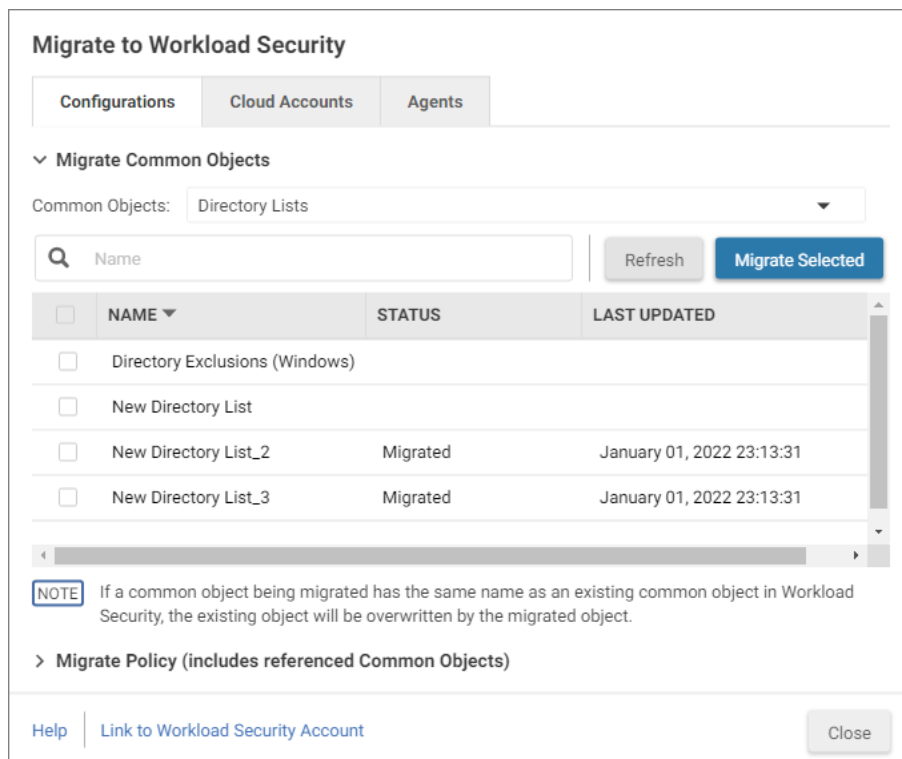

Next, migrate your [cloud accounts](#) and [agents](#).

Migrate cloud accounts to Workload Security

Tip: This is one part of the process for migrating from Deep Security to Workload Security. For a complete picture of the migration process, see ["Migrate from Deep Security to Workload Security" on page 1697](#).

You may have used cloud connectors to add cloud accounts to Deep Security. You can use the migration tool or migration API to migrate protected cloud accounts.

Prerequisites

- Check that you're running Deep Security Manager 20.0.635 (20 LTS Update 2022-04-21) or later.
- If you haven't done so already, complete the earlier steps described in ["Migrate from Deep Security to Workload Security" on page 1697](#), including creating a Trend Cloud One account, creating an API key, and preparing a link to Workload Security.

If you are migrating AWS accounts

Note: If you are migrating accounts that are not AWS, please see ["Migrate other cloud accounts using the migration tool"](#) on page 1716 for details.

Limitations

The procedure used to migrate registered AWS accounts depends on [how they were originally added to Deep Security Manager](#):

- AWS accounts added using access keys can be migrated using the migration tool or migration API.
- AWS accounts added using cross-account roles can be migrated using the migration tool or migration API. However, those cross-account roles need to be configured to trust the AWS principal of Workload Security in addition to the original principal of Deep Security Manager. See ["Migrate AWS accounts that were added using cross-account roles"](#) below for details.
- AWS accounts added using manager instance roles are not supported on Workload Security. Migration of these accounts is not supported.
- Legacy AWS accounts that were added in Deep Security Manager 9.6 or earlier are not supported because they are not accessible via the API endpoint `/api/awsconnectors`.

Migrate AWS accounts that were added using cross-account roles

There are 2 ways to register AWS accounts to Workload Security:

- ["Create a new cross-account role"](#) below for each AWS account.
- ["Re-use existing cross-account roles"](#) below for Deep Security Manager.

Create a new cross-account role

With this method, instead of using the migration tool or API, you add new cross-account roles that allow Workload Security to access your AWS accounts. For instructions, see [Add an AWS account using a cross-account role](#) in the Workload Security help.

Re-use existing cross-account roles

With this method, you identify the original cross-account role, configure the trust relationship to Workload Security, and invoke the migration API:

1. Identify the cross-account role in your AWS account that allows Deep Security Manager to access it.

You can find the role ARN in the Deep Security Manager console by right-clicking the AWS account and selecting Properties.

The role ARN is in this format, `arn:aws:iam::<AWS account ID>:role/<role name>`

2. Note the AWS account of Workload Security and the external ID of your tenant. Refer to [this article in the Workload Security help](#) for the account ID and how to retrieve the external ID.
3. Log in to the AWS account. In the AWS console, go to the **IAM service**.
4. In the left navigation pane, click **Roles**.
5. In the main pane, find the role name from step 1 and click it to open the summary page.
6. In the **Trust relationships** tab, click **Edit trust relationship**.
7. In the Policy Document, the trust relationship should look like this:

```
{
  "Version": "2012-10-17",
  "Statement": [
    {
      "Effect": "Allow",
      "Principal": {
        "AWS": "arn:aws:iam::<original Deep Security AWS
Account>:root"
      },
      "Action": "sts:AssumeRole",
      "Condition": {
        "StringEquals": {
          "sts:ExternalId": "<original Deep Security External ID>"
        }
      }
    }
  ]
}
```

8. Add the noted Workload Security account (147995105371) and the external ID to the Policy Document (the first statement). It should look like this:

```
{
  "Version": "2012-10-17",
```

```

"Statement": [
  {
    "Effect": "Allow",
    "Principal": {
      "AWS": "arn:aws:iam::147995105371:root"
    },
    "Action": "sts:AssumeRole",
    "Condition": {
      "StringEquals": {
        "sts:ExternalId": "<Workload Security External ID>"
      }
    }
  },
  {
    "Effect": "Allow",
    "Principal": {
      "AWS": "arn:aws:iam::<original Deep Security AWS
Account>:root"
    },
    "Action": "sts:AssumeRole",
    "Condition": {
      "StringEquals": {
        "sts:ExternalId": "<original Deep Security External ID>"
      }
    }
  }
]
}

```

9. Click **Update Trust Policy** to save the changes.
10. Repeat this procedure for each AWS account that you want to migrate to Workload Security.
11. Migrate the AWS accounts using the migration tool or migration API.

Migrate other cloud accounts using the migration tool

1. In upper-right corner of the Deep Security Manager console, select **Support > Migrate to Workload Security**.

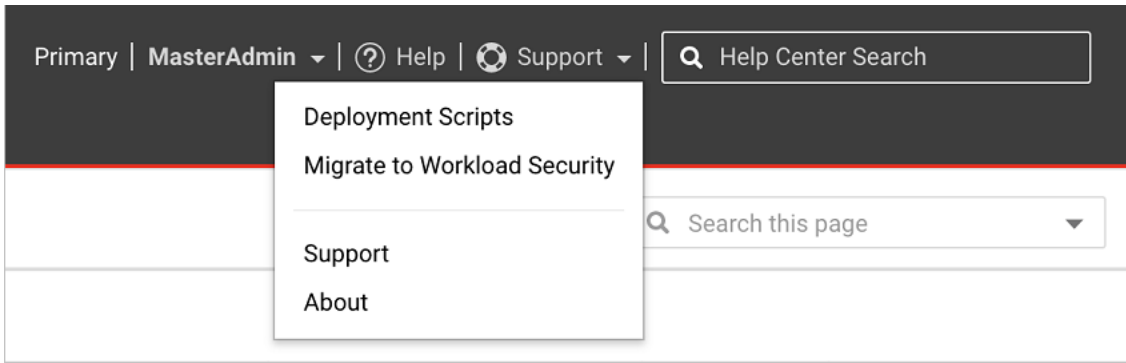

2. The **Migrate to Workload Security** page appears. Click the **Cloud Accounts** tab.

Migrate to Workload Security

- Configurations
- Cloud Accounts
- Agents

> Migrate AWS Accounts

> Migrate Azure Accounts

∨ Migrate GCP Accounts

Refresh

<input type="checkbox"/>	GCP ACCOUNT ▼	STATUS	LAST UPDATE
<input type="checkbox"/>	A GCP account		

[Help](#)

[Link to Workload Security Account](#)

3. All connected cloud accounts that support migration are displayed. Select the accounts that you want to migrate and click **Migrate Selected**.
4. The migration begins. Click the **Refresh** button to check the migration status. Possible statuses are:
 - **Migration requested:** Cloud account migration to Workload Security has been requested but the migration hasn't started yet.
 - **Migrating:** Cloud accounts are being migrated to Workload Security and a full synchronization has been started. This process might take time to complete.
 - **Migrated:** Cloud accounts have been migrated successfully to Workload Security.
 - **Failed:** Cloud accounts have failed to migrate to Workload Security for some reason. Check the error code:
 - Error codes **less than 900:** There is a failure from Workload Security, see the fail system event for response detail or contact support.
 - Error codes **greater than or equal to 900:** Deep Security Manager has a problem communicating with Workload Security. Please make sure the Workload Security Link is correctly configured, or check `server0.log` for details.

Migrate VMware vCloud accounts

VMware vCloud accounts currently cannot be migrated automatically to Workload Security. However, you can create new VMware vCloud connectors in your Workload Security account to protect them. This can be done before or after hosts are migrated and reactivated, but we recommend setting it up prior to host migration.

To learn how to set up cloud connectors in Workload Security, see this article in the Workload Security help:

- [Add virtual machines hosted on VMware vCloud](#)

Migrate agents to Workload Security

Tip: This is one part of the process for migrating from Deep Security to Workload Security. For a complete picture of the migration process, see "[Migrate from Deep Security to Workload Security](#)" on page 1697.

Prerequisites

- Check that you're using Deep Security Manager 20.0.321 (20 LTS 2021-01-26) or later for migrating via APIs, or Deep Security Manager 20.0.513 (20 LTS Update 2021-10-14) or later for migrating using the Deep Security Manager migration tool.
- Check that you're using Deep Security Agent 20.0.0-3445 (20 LTS Update 2021-11-24) or later. Then, in the Workload Security console, go to **Administration > Updates > Software > Local** and make sure your account has the corresponding Deep Security Agent package.
- Check that your agents are running on platforms that support migration:
 - The [Agent platform support table](#) lists agent platforms supported by Deep Security Manager 20.
 - Migrating agents is currently fully validated only on Windows and Linux platforms on Intel architecture.
 - Migrating agents is not supported on Windows 2008 32-bit.
- Due to feature differences between Deep Security Manager and Workload Security, disable these features before migrating agents.
 - [FIPS 140](#): Deep Security Manager will refuse to migrate if FIPS 140 is enabled.
 - [Virtual Appliance](#): Computers protected by Virtual Appliance ([agent-less or combined-mode](#)) will refuse to migrate.
- If you haven't done so already, complete the earlier steps described in "[Migrate from Deep Security to Workload Security](#)" on page 1697, including creating a Trend Cloud One account, creating an API key, and preparing a link to Workload Security.

Migrate agents using the migration tool

1. In upper-right corner of the Deep Security Manager console, select **Support > Migrate to Workload Security**.

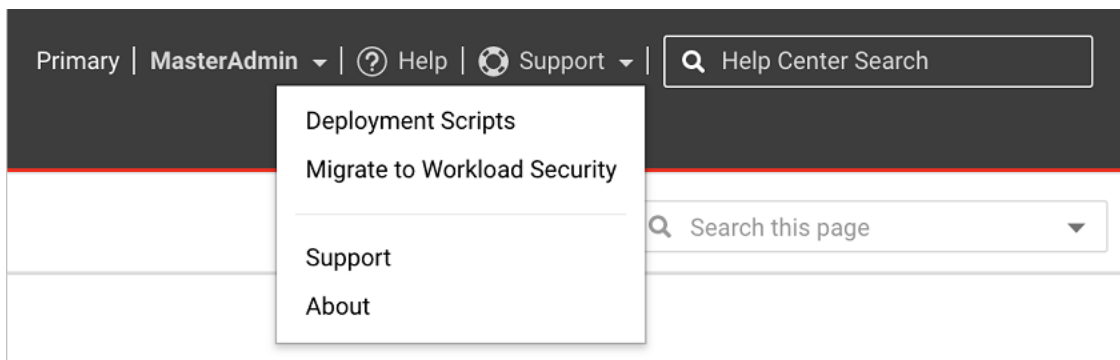

2. On the **Migrate to Workload Security** page that appears, select the **Agents** tab.
3. Select **Migrate using Computers** page. The Deep Security **Computers** page is displayed.
4. Select one or more computers that you want to migrate.
5. Select **Actions > Migrate to Workload Security**.
6. In the dialog box that appears, specify the settings that you want applied to the agents when moved, and then select **Migrate**:

Cloud One Workload Security Agent Reactivation Configurations

Specify Agent Settings

Security Policy: Assign migrated policy
 Select a policy from Workload Security
 None

Computer Group: Computers

Relay Group: Primary Tenant Relay Group

Advanced Settings

Proxy to contact Workload Security Manager: Select a proxy...

Proxy to contact Relay(s): Select a proxy...

Migrate with existing hostname, display name and description
 Migrate with settings overridden at computer level

Help | [Link to Workload Security Account](#) Migrate Close

- **Security Policy:** If you have migrated your Deep Security policies to Workload Security and want to keep the same policy applied to the migrated agent, select **Assign migrated policy**. If you want to assign a different policy, choose **Select a policy from Workload Security** and select the new policy.

- **Computer Group:** The computer group where the agents will be put in Workload Security.
 - **Relay Group:** All agents will be assigned to the Primary Relay Group in Workload Security.
 - **Proxy to contact Workload Security Manager:** Select a proxy if agents need one to contact Workload Security.
 - **Proxy to contact Relay(s):** Select a proxy if agents need one to contact relays on Workload Security.
 - **Migrate with existing hostname, display name, and description:** Select this to use the existing hostname, display name, and description for the migrated agent.
 - **Migrate with settings override at computer level:** Select this to migrate any settings that have an override at the computer level. This does not include rule assignments.
7. ["Check the move status" below.](#)
 8. If you run into problems, check ["Troubleshooting" on page 1728](#)

Check the move status

The status of move tasks is available from the API response, computers page, and system events. The move status is also a search criteria in [smart folders](#).

The original state of a move task is that the agent is managed by an on-premises Deep Security Manager.

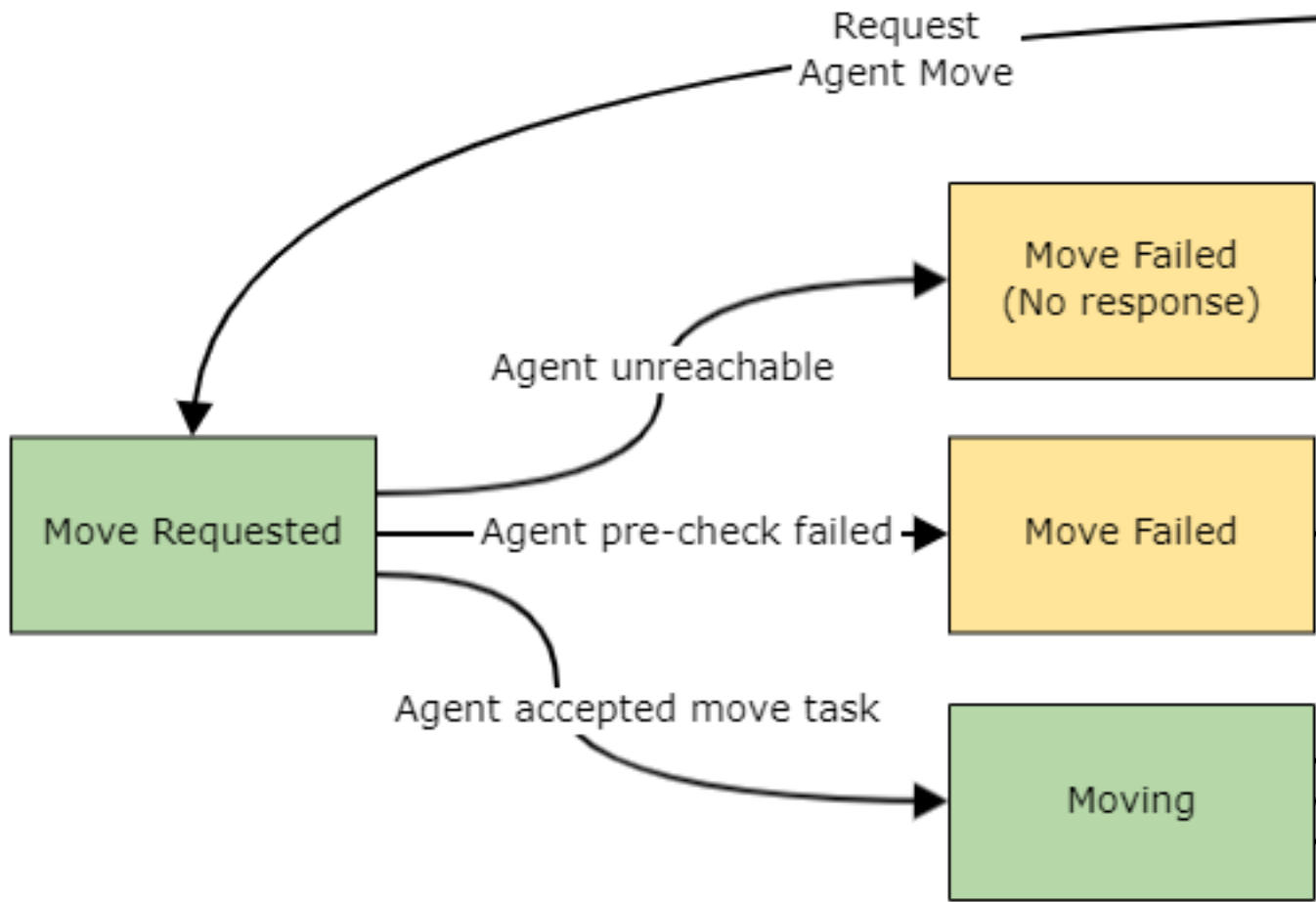

Status	Description	How to recover to original state
Move Requested	<p>A move task to Workload Security has been requested.</p> <p>The move task has been accepted by Deep Security Manager, but not yet sent to the</p>	N/A

Status	Description	How to recover to original state
	agent.	
Moving	<p>Computer is being moved to Workload Security.</p> <p>The agent has accepted the move task, and is moving to Workload Security.</p>	N/A
Move Complete	<p>Computer has been moved successfully to Workload Security.</p> <p>Deep Security Manager is able to identify that the moved agent is activated on Workload Security.</p>	<p>Manually reactivate the agent back to Deep Security Manager.</p> <p>Note that the agent has already trusted the Workload Security public certificate. You must remove the <code>ds_agent_dsm_public_ca.crt</code> file manually before activating the agent back to Deep Security Manager.</p>
Move Failed	<p>Computer was not moved to Workload Security due to a connectivity issue from the agent to Workload Security.</p> <p>The agent has rejected the move task while performing its pre-check.</p> <p>Before trying the move again:</p> <ul style="list-style-type: none"> • Check that all parameters specified for the move are correct, including the account information, activation token, public CA certificate, and proxy settings. • Check that there are no networking/firewall settings preventing the agent from reaching Workload Security. • Use the CLI to create an agent diagnostic package, which will include a <code>ds_agent.log</code> file containing information about the failed move. For instructions on creating diagnostic 	<p>Clear Warnings on the console.</p> <p>The agent is still managed by Deep Security Manager.</p>

Status	Description	How to recover to original state
	<p>packages, see Create a diagnostic package and logs.</p>	
Move Failed (No response)	<p>Computer was not moved to Workload Security because the agent did not respond to the move task in a timely manner.</p> <p>Before trying the move again:</p> <ul style="list-style-type: none"> • Check that the agent is up and running. • Check that the agent can communicate properly with Deep Security Manager. 	<p>Clear warnings on the console.</p> <p>The agent is still managed by Deep Security Manager.</p>
Move Failed (Failed to activate)	<p>The move to Workload Security failed due to an activation issue and was rolled back.</p> <p>The pre-check passed, but the agent was unable to activate to Workload Security.</p> <p>Before trying the move again:</p> <ul style="list-style-type: none"> • Check that the Workload Security Link is up to date. • Check that all parameters specified for the move are correct, including the account information, activation token, public CA certificate, and proxy settings. • Use the CLI to create an agent diagnostic package, which will include <code>dsa_move.log</code> and <code>dsa_control.log</code> files containing information about the failed move. For instructions on creating diagnostic packages, see Create a diagnostic package and logs. 	<p>Clear warnings on the console.</p> <p>The agent is still managed by Deep Security Manager.</p>
Move Failed (Unmanaged)	The move to Workload Security failed due to an activation issue, and the move could not	Manually restore the agent back to Deep Security Manager.

Status	Description	How to recover to original state
	<p>be rolled back automatically. The computer is in an unmanaged state.</p> <p>The pre-check is passed, but the agent was unable to activate to Workload Security.</p> <p>An agent in this state may have encountered unknown issues during roll back, and the agent needs manual intervention.</p> <p>To troubleshoot this issue:</p> <ul style="list-style-type: none"> • Look into the <code>dsa_move.log</code> file, which contains information about the failed move. • Manually restore the agent or reactivate the agent. See the Troubleshooting section for more details. <p>Before trying the move again:</p> <ul style="list-style-type: none"> • Check that the Workload Security Link is up to date. • Check that all parameters specified for the move are correct, including the account information, activation token, public CA certificate, and proxy settings. 	<p>The agent is still protecting the host computer but is not being managed by Deep Security Manager.</p> <p>See the Troubleshooting section for more details.</p>

Use Smart Folder to view move status

1. From the [Smart Folder](#) Editor, expand the **Search Criteria**.
2. In the first drop-down list, select the property **Status: Move Status**.
3. In the second drop-down list, select a value such as **Move Complete** or **Move Failed**.

Smart Folder Editor

General Information

Folder Display Name:

Search Criteria

Use this query builder to define the filtering rule(s) Deep Security will use to dynamically populate your Smart Folder. Create a rule by selecting a computer property and then specifying the condition that property must meet. For example, you can create a rule which will select all computers whose hostname contains the string "gold". You can use multiple rules to specify multiple conditions that must be met for a computer to be display in the folder.

AND OR
+ Add Rule Group

AND OR
+ Add Rule ✖ Delete Group

Status: Move Status EQUALS All Move Statuses ✖

All Move Statuses
Move Requested
Moving
Move Complete
Move Failed
Move Failed (Failed to activate)
Move Failed (Unmanaged)

Organize by Tag or Label Key Values

Within your Smart Folder, Deep Security can automatically create sub-folders based on the values of a specific tag or label key. If you provide the tag or label key, Deep Security will create a sub-folder for each value and place the matching computers in the sub-folder.

Troubleshooting

Restore an unmanaged agent manually

Check the `dsa_move.log` file to identify the root cause of the move failure. The agent restore may have failed because the agent failed to stop or failed to start.

Agent failed to stop

If the agent failed to stop during the restore process, the following error message will be seen in the logs:

```
Unable to stop the agent. Agent restore failed.
```

Here is how to restore the agent:

1. Stop the agent service.
2. Restore the agent backup.
 - a. Locate the agent work directory.
 - Agent work directory in Windows: `%ProgramData%\Trend Micro\Deep Security Agent\`
 - Agent work directory in Linux/Unix: `/var/opt/ds_agent/`

- b. Within that directory, the backup name starts with `backup_` and ends with the date. For example: `backup_2021-05-11_20.11.45`
 - c. Remove everything from the agent work directory except for the `diag` and `backup_*` directories.
 - d. Copy everything from the `backup_*` directory to the agent work directory.
3. Start the agent service.
 4. Send a heartbeat to Deep Security Manager using `dsa_control -m`
 5. Remove the `backup_*` directory if the agent was restored successfully (activated successfully with Deep Security Manager).

Agent failed to start

If the agent failed to start during the restore process, the following error message will be seen in the logs:

```
Unable to start the agent. Agent restore failed.
```

Here is how to restore the agent:

1. Start the agent service.
2. Send a heartbeat to Deep Security Manager using `dsa_control -m`

Other methods for migrating agents

If your environment contains sufficient automation tools, you can reactivate agents by extracting the activation command from deployment scripts within the Workload Security console. New hosts that don't have an agent should run the entire script. Hosts with existing up-to-date agents can just run the `dsa_control` command located in a comment at the end of the deployment script. If proxies are in use, note the several lines preceding this command and execute them with the correct values prior to running the activation command. Reactivation does not require a reboot or cause loss of protection during the process.

Environments without sufficient automation infrastructure can use the Deep Security MoveAgent API. This reactivates agents automatically, using the Workload Security Link configured for the target Workload Security account. This method requires Deep Security Manager 20.0.321 (20 LTS 2021-01-26) or later and Deep Security Agent 20.0.0-3445 (20 LTS Update 2021-11-24) or later. For instructions, ["Migrate using the Deep Security and Workload Security APIs" on page 1705](#).

We recommend that you enable the option in Workload Security to [automatically upgrade agents on activation](#) to ensure you will get the full security control provided with the latest agent. The

minimum agent version available in each [Trend Cloud One region](#) is different. Trend Micro recommends using the latest agent version whenever possible, but if you require an older agent version that is not available in your account, please contact Trend Micro support.

DevOps, automation, and APIs

About DevOps, automation, and APIs

To support DevOps workflows, Deep Security offers APIs to automate, monitor, and manage security throughout the release lifecycle. (See ["Use the Deep Security API to automate tasks"](#) on [page 1764](#).)

The Trend Micro Hybrid Cloud Security Command Line Interface (THUS) is a tool that can help you easily navigate the API. For more information, see <https://github.com/trendmicro/thus>.

The [deep-security GitHub](#) repositories contain the following useful scripts:

- [CloudFormation templates for deploying Deep Security Manager to AWS.](#)
- [Configuration files that contain parsing logic, saved searches, and dashboards for monitoring Deep Security via Splunk.](#)
- [Bash and Powershell scripts for automating various Agent and Manager tasks.](#)

To get started with the API, see the [First Steps Toward Deep Security Automation](#) guide in the Deep Security Automation Center. The Automation Center also includes an [API Reference](#).

Deep Security also offers many other ways to speed up the protection of your computers and other resources:

- ["Schedule Deep Security to perform tasks" on page 1766](#)
- ["Automatically perform tasks when a computer is added or changed \(event-based tasks\)" on page 1769](#)
- ["AWS Auto Scaling and Deep Security" on page 1776](#)
- ["Use deployment scripts to add and protect computers" on page 1790](#)
- ["Automatically assign policies using cloud provider tags/labels" on page 1802](#)
- ["Command-line basics" on the next page](#)

In addition, Deep Security provides the ability to forward events to SIEMs such as Splunk, QRadar, ArcSight, as well as Amazon SNS. For details, see:

- ["Forward Deep Security events to a Syslog or SIEM server" on page 1146](#)
- ["Set up Amazon SNS" on page 1214](#)

Trend Micro Hybrid Cloud Security Command Line Interface (THUS)

Trend Micro Hybrid Cloud Security Command Line Interface (THUS) is a tool that you can use to help deploy, configure and maintain your Deep Security environments. THUS is easy to install and configure, all from your terminal.

For more information about setting up the Trend Micro Hybrid Cloud Security Command Line Interface (THUS), see <https://github.com/trendmicro/thus>.

Command-line basics

You can use the local command-line interface (CLI) to instruct Deep Security Agents and Deep Security Manager to perform actions. You can also use the CLI to configure some settings and display the system resource usage information.

You can automate various CLI commands using the Deep Security API (see [First Steps Toward Deep Security Automation](#)).

- ["dsa_control" below](#)
- ["dsa_query" on page 1747](#)
- ["dsa_scan" on page 1749](#)
- ["dsm_c" on page 1753](#)

dsa_control

The `dsa_control` enables you to configure some of the Deep Security Agent settings and manually trigger such actions as activation, anti-malware scans, and baseline rebuilds.

Note that on Windows OS, when [self-protection is enabled](#), a local user cannot uninstall, update, stop, or otherwise control Deep Security Agent. In addition, the authentication password must be supplied when running CLI commands.

`dsa_control` only supports English strings. Unicode is not supported.

To use `dsa_control`:

On Windows:

1. Open a command prompt as administrator.
2. Change to the Deep Security Agent's installation directory. For example:

```
cd C:\Program Files\Trend Micro\Deep Security Agent\
```

3. Execute the `dsa_control` command:

```
dsa_control <option>
```

where `<option>` is replaced with one of the options described in "[dsa_control options](#)" below.

On Linux, AIX, and Solaris:

- `sudo /opt/ds_agent/dsa_control <option>`

where `<option>` is replaced with one of the options described in "[dsa_control options](#)" below

Running multiple `dsa_control` commands can result in a more recent command overwriting an earlier one. If you want to run multiple commands, you should list the parameters side by side. For example, `dsa_control -m "RecommendationScan:true" "UpdateComponent:true"`

In general, it is recommended to use the Scheduled Tasks UI (**Administration > Scheduled Tasks**) for managing the Deep Security Agent tasks. For more information, see "[Schedule Deep Security to perform tasks](#)" on page 1766.

dsa_control options

```
dsa_control [-a <str>] [-b] [-c <str>] [-d] [-g <str>] [-s
<num>] [-m] [-p <str>] [-r] [-R <str>] [-t <num>] [-u <str>:<str>] [-w
<str>:<str>] [-x dsm_proxy://<str>] [-y relay_proxy://<str>] [--
buildBaseline] [--scanForChanges] [Additional keyword:value data to send
```

```
to manager during activation or heartbeat...]
```

Parameter	Description
<pre>-a <str>, -- activate=<str></pre>	<p>Activate agent with manager at the specified URL in this format:</p> <pre>dsm://<host>:<port>/</pre> <p>where:</p> <ul style="list-style-type: none"> • <code><host></code> could be either the manager's fully qualified domain name (FQDN), IPv4 address, or IPv6 address • <code><port></code> is the manager's listening port number <p>Optionally, after the argument, you can also specify some settings such as the description to send during activation. See "Agent-initiated heartbeat command ("dsa_control -m")" on page 1737. They must be entered as key:value pairs with a colon as a separator. There is no limit to the number of key:value pairs that you can enter, but the key:value pairs must be separated from each other by a space. Quotation marks around the key:value pair are required if it includes spaces or special characters.</p>
<pre>-b, --bundle</pre>	Create an update bundle.
<pre>-c <str>, -- cert=<str></pre>	Identify the certificate file.
<pre>-d, --diag</pre>	Generate an agent package. For details, see " Create an agent diagnostic package via CLI on a protected computer " on page 1954.
<pre>-g <str>, -- agent=<str></pre>	<p>Agent URL. Defaults to:</p> <pre>https://localhost:<port>/</pre> <p>where <code><port></code> is the manager's listening port number.</p>
<pre>-m, --heartbeat</pre>	Force the agent to contact the manager now.
<pre>-p <str> or --</pre>	The authentication password that you might have configured in

Parameter	Description
<code>passwd=<str></code>	<p>Deep Security Manager previously. See "Configure self-protection through Deep Security Manager" on page 1467 for details. If configured, the password must be included with all <code>dsa_control</code> commands except <code>dsa_control -a</code>, <code>dsa_control -x</code>, and <code>dsa_control -y</code>.</p> <p>Example: <code>dsa_control -m -p MyPa\$\$w0rd</code></p> <p>If you type the password directly into the command line, it is displayed on the screen. To hide the password with asterisks (*) while you type, enter the interactive form of the command, <code>-p *</code>, which prompts you for the password.</p> <p>Example:</p> <pre>dsa_control -m -p *</pre>
<code>-r, --reset</code>	<p>Reset the agent's configuration. This removes the activation information from the agent and deactivates it.</p>
<code>-R <str>, --restore=<str></code>	<p>Restore a quarantined file. On Windows, you can also restore cleaned and deleted files.</p>
<code>-s <num>, --selfprotect=<num></code>	<p>Enable the agent self-protection (1: enable, 0: disable). Self-protection prevents local end-users from uninstalling, stopping, or otherwise controlling the agent. For details, see "Enable or disable agent self-protection on Windows" on page 1466. This is a Windows-only feature.</p> <p>Although <code>dsa_control</code> lets you enable self-protection, it does not allow you to configure an associated authentication password. You need Deep Security Manager for that. See "Configure self-protection through Deep Security Manager" on page 1467 for details. Once configured, the password must be entered at the command line using the <code>-p</code> or <code>--passwd=</code> option.</p> <p>In Deep Security 9.0 and earlier, this option was <code>-H <num>, --harden=<num></code></p>

Parameter	Description
<pre>-t <num>, -- retries=<num></pre>	<p>If <code>dsa_control</code> cannot contact the agent service to carry out accompanying instructions, this parameter instructs <code>dsa_control</code> to retry <code><num></code> number of times. There is a 1 second pause between retries.</p>
<pre>-u <user>:<password></pre>	<p>Used in conjunction with the <code>-x</code> option to specify the proxy's username and password, if the proxy requires authentication. Separate the username and password by a colon (:). For example, # <code>./dsa_control -x dsm_proxy://<str> -u <new username>:<new password></code>.</p> <p>To remove the username and password, type an empty string (""). For example, # <code>./dsa_control -x dsm_proxy://<str> -u <existing username>:""</code>.</p> <p>If you only want to update the proxy's password without changing the proxy's username, you can use the <code>-u</code> option without <code>-x</code>. For example, # <code>./dsa_control -u <existing username>:<new password></code>.</p> <p>Basic authentication only. Digest and NTLM are not supported.</p> <p>Using <code>dsa_control -u</code> only applies to the agent's local configuration. No security policy is changed on the manager as a result of running this command.</p>
<pre>-w <user>:<password></pre>	<p>Used in conjunction with the <code>-y</code> option to specify the proxy's username and password, if the proxy requires authentication. Separate the username and password by a colon (:). For example, # <code>./dsa_control -y relay_proxy://<str> -w <new username>:<new password></code>.</p> <p>To remove the username and password, type an empty string (""). For example, # <code>./dsa_control -y relay_proxy://<str> -w <existing username>:""</code>.</p> <p>If you only want to update the proxy's password without changing the proxy's username, you can use the <code>-w</code> option without <code>-y</code>. For example, # <code>./dsa_control -w <existing username>:<new</code></p>

Parameter	Description
	<p><code>password></code>.</p> <p>Basic authentication only. Digest and NTLM are not supported.</p> <p>Note that using <code>dsa_control -w</code> only applies to the agent's local configuration. No security policy is changed on the manager as a result of running this command.</p>
<p><code>-x dsm_</code> <code>proxy://<str>:<num></code></p>	<p>Configure a proxy between the agent and manager. Provide the proxy's IPv4/IPv6 address or FQDN and port number, separated by a colon (:). Square brackets must surround IPv6 addresses. For example: <code>dsa_control -x "dsm_proxy://[fe80::340a:7671:64e7:14cc]:808/"</code>. To remove the address, instead of a URL, type an empty string ("").</p> <p>See also the <code>-u</code> option.</p> <p>For more information, see "Connect to Deep Security Manager via proxy" on page 1407.</p> <p>Note that using <code>dsa_control -x</code> only applies to the agent's local configuration. No security policy is changed on the manager as a result of running this command.</p>
<p><code>-y relay_</code> <code>proxy://<str>:<num></code></p>	<p>Configure a proxy between an agent and relay. Provide the proxy's IP address or FQDN and port number, separated by a colon (:). Square brackets must surround IPv6 addresses. For example: <code>dsa_control -y "relay_proxy://[fe80::340a:7671:64e7:14cc]:808/"</code>. To remove the address, instead of a URL, type an empty string ("").</p> <p>See also the <code>-w</code> option.</p> <p>For more information, see "Connect to Deep Security Relays via proxy" on page 1408.</p> <p>Note that using <code>dsa_control -y</code> only applies to the agent's local configuration. No security policy is changed on the manager as a result of running this command.</p>
<p><code>--buildBaseline</code></p>	<p>Build the baseline for Integrity Monitoring.</p>

Parameter	Description
<code>--scanForChanges</code>	Scan for changes for Integrity Monitoring.
<code>--max-dsm-retries</code>	Number of times to retry an activation. Valid values are 0 to 100, inclusive. The default value is 30.
<code>--dsm-retry-interval</code>	Approximate delay in seconds between retrying activations. Valid values are 1 to 3600, inclusive. The default value is 300.

Agent-initiated activation ("dsa_control -a")

Enabling agent-initiated activation (AIA) can prevent communication issues between the manager and agents, and simplify agent deployment when used with deployment scripts.

For instructions on how to configure AIA and use deployment scripts to activate agents, see ["Activate and protect agents using agent-initiated activation and communication" on page 1460](#).

The command takes the form:

```
dsa_control -a dsm://<host>:<port>/
```

where:

- `<host>` could be either the manager's fully qualified domain name (FQDN), IPv4 address, or IPv6 address.
- `<port>` is the agent-to-manager communication [port number](#) (4120 by default).

For example:

```
dsa_control -a dsm://dsm.example.com:4120/ hostname:www12
"description:Long Description With Spaces"
```

```
dsa_control -a dsm://fe80::ad4a:af37:17cf:8937:4120
```

Agent-initiated heartbeat command ("dsa_control -m")

You can force the agent to immediately send a heartbeat to the manager.

Like activation, the heartbeat command can also send settings to the manager during the connection.

Parameter	Description	Example	Use during Activation	Use during Heartbeat
<code>AntiMalwareCancelManualScan</code>	Boolean. Cancels an on-demand ("manual") scan that is currently occurring on the computer.	<code>"AntiMalwareCancelManualScan:true"</code>	no	yes
<code>AntiMalwareManualScan</code>	Boolean. Initiates an on-demand ("manual") anti-malware scan on the computer.	<code>"AntiMalwareManualScan:true"</code>	no	yes
<code>description</code>	String. Sets the computer's description. Maximum length 2000 characters.	<code>"description:Extra information about the host"</code>	yes	yes
<code>displayname</code>	String. Sets the display name shown in parentheses next to the hostname on Computers . Maximum length 2000	<code>"displayname:the_name"</code>	yes	yes

Parameter	Description	Example	Use during Activation	Use during Heartbeat
	characters.			
<code>externalid</code>	<p>Integer.</p> <p>Sets the <code>externalid</code> value. This value can be used to uniquely identify an agent. The value can be accessed using the legacy SOAP web service API.</p>	<code>"externalid:123"</code>	yes	yes
<code>group</code>	<p>String.</p> <p>Sets which group the computer belongs to on Computers. Maximum length 254 characters per group name per hierarchy level.</p> <p>The forward slash ("/") indicates a</p>	<code>"group:Zone A web servers"</code>	yes	yes

Parameter	Description	Example	Use during Activation	Use during Heartbeat
	<p>group hierarchy. The <code>group</code> parameter can read or create a hierarchy of groups. This parameter can only be used to add computers to standard groups under the main "Computers" root branch. It cannot be used to add computers to groups belonging to directories (Microsoft Active Directory), VMware vCenters, or cloud provider accounts.</p>			
<code>groupid</code>	Integer.	"groupid:33"	yes	yes
<code>hostname</code>	String. Maximum	"hostname:www1"	yes	no

Parameter	Description	Example	Use during Activation	Use during Heartbeat
	<p>length 254 characters.</p> <p>The hostname can specify an IP address, hostname or FQDN that the manager can use to connect to the agent.</p>			
<code>IntegrityScan</code>	<p>Boolean.</p> <p>Initiates an integrity scan on the computer.</p>	<code>"IntegrityScan:true"</code>	no	yes
<code>policy</code>	<p>String.</p> <p>Maximum length 254 characters.</p> <p>The policy name is a case-insensitive match to the policy list. If the policy is not found, no policy is assigned.</p> <p>A policy</p>	<code>"policy:Policy Name"</code>	yes	yes

Parameter	Description	Example	Use during Activation	Use during Heartbeat
	assigned by an event-based task overrides a policy assigned during agent-initiated activation.			
<code>policyid</code>	Integer.	"policyid:12"	yes	yes
<code>relaygroup</code>	String. Links the computer to a specific relay group. Maximum length 254 characters. The relay group name is a case-insensitive match to existing relay group names. If the relay group is not found, the default relay group is used. This does not	"relaygroup:Custom Relay Group"	yes	yes

Parameter	Description	Example	Use during Activation	Use during Heartbeat
	affect relay groups assigned during event-based tasks. Use either this option or event-based tasks, not both.			
<code>relaygroupid</code>	Integer.	"relaygroupid:123"	yes	yes
<code>relayid</code>	Integer.	"relayid:123"	yes	yes
<code>tenantIDand token</code>	String. If using agent-initiated activation as a tenant, both <code>tenantID</code> and <code>token</code> are required. The <code>tenantID</code> and <code>token</code> can be obtained from the deployment script generation tool.	"tenantID:12651ADC-D4D5" and "token:8601626D-56EE"	yes	yes
<code>RecommendationScan</code>	Boolean. Initiate a recommendation scan on the computer.	"RecommendationScan:true"	no	yes

Parameter	Description	Example	Use during Activation	Use during Heartbeat
UpdateComponent	<p>Boolean.</p> <p>Instructs Deep Security Manager to perform a security update.</p> <p>When using the <code>UpdateComponent</code> parameter on Deep Security Agent 12.0 or later, make sure the Deep Security Relay is also at version 12.0 or later. Learn more.</p>	"UpdateComponent:true"	no	yes
RebuildBaseline	<p>Boolean.</p> <p>Rebuilds the Integrity Monitoring baseline on the computer.</p>	"RebuildBaseline:true"	no	yes
UpdateConfiguration	<p>Boolean.</p> <p>Instructs Deep Security Manager to perform a</p>	"UpdateConfiguration:true"	no	yes

Parameter	Description	Example	Use during Activation	Use during Heartbeat
	"Send Policy" operation.			

Activate Deep Security Agent

To activate an agent from the command line, you need to know the tenant ID and password. You can get them from the deployment script.

1. In the top right corner of Deep Security Manager, click **Support > Deployment Scripts**.
2. Select your platform.
3. Select **Activate Agent automatically after installation**.
4. In the deployment script, locate the strings for `tenantID` and `token`.

Windows

In PowerShell:

```
& $Env:ProgramFiles"\Trend Micro\Deep Security Agent\dsa_control" -a
<manager URL> <tenant ID> <token>
```

In cmd.exe:

```
C:\Windows\system32>"\Program Files\Trend Micro\Deep Security Agent\dsa_
control" -a <manager URL> <tenant ID> <token>
```

Linux, AIX, and Solaris

```
/opt/ds_agent/dsa_control -a <manager URL> <tenant ID> <token>
```

Force the agent to contact the manager

Windows

In PowerShell:

```
& "\Program Files\Trend Micro\Deep Security Agent\dsa_control" -m
```

In cmd.exe:

```
C:\Windows\system32>"\Program Files\Trend Micro\Deep Security Agent\dsa_
control" -m
```

Linux, AIX, and Solaris

```
/opt/ds_agent/dsa_control -m
```

Initiate a manual anti-malware scan

Windows

1. Open a command prompt (cmd.exe) as Administrator.
2. Enter these commands:

```
cd C:\Program Files\Trend Micro\Deep Security Agent\  
dsa_control -m "AntiMalwareManualScan:true"
```

Linux, AIX, and Solaris

```
/opt/ds_agent/dsa_control -m "AntiMalwareManualScan:true"
```

Create a diagnostic package

If you need to troubleshoot a Deep Security Agent issue, your support provider might ask you to create and send a diagnostic package from the computer. For more detailed instructions, see ["Create an agent diagnostic package via CLI on a protected computer" on page 1954](#).

You can produce a diagnostic package for a Deep Security Agent computer through the Deep Security Manager but if the agent computer is configured to use [Agent/Appliance Initiated communication](#), then the manager cannot collect all the required logs. So when Technical Support asks for a diagnostic package, you need to run the command directly on the agent computer.

Reset the agent

This command removes the activation information from the target agent and deactivates it.

Windows

In PowerShell:

```
& "& "\Program Files\Trend Micro\Deep Security Agent\dsa_control" -r
```

In cmd.exe:

```
C:\Windows\system32>"\Program Files\Trend Micro\Deep Security Agent\dsa_  
control" -r
```

Linux, AIX, and Solaris

```
/opt/ds_agent/dsa_control -r
```

dsa_query

You can use the `dsa_query` command to display agent information.

dsa_query options

```
dsa_query [-c <str>] [-p <str>] [-r <str>]
```

Parameter	Description
<pre>-p, -- passwd <string></pre>	<p>Authentication password used with the optional agent self-protection feature. Required if you specified a password when enabling self-protection.</p> <p>For some query-commands, authentication can be bypassed directly, in which case password is not required.</p>
<pre>-c, --cmd <string></pre>	<p>Execute query-command against the agent. The following commands are supported:</p> <ul style="list-style-type: none"> "GetHostInfo": to query which identity is returned to the manager during a heartbeat "GetAgentStatus": to query which protection modules are enabled, the status of Anti-Malware or Integrity Monitoring scans in progress, and other miscellaneous information "GetComponentInfo": to query version information of anti-malware patterns and engines "GetPluginVersion": to query version information of the agent and protection modules "GetProxyInfo": to query proxy information of all proxy types
<pre>-r, --raw <string></pre>	<p>Returns the same query-command information as "-c" but in raw data format for third party software interpretation.</p>
<pre>pattern</pre>	<p>1. Wild card pattern to filter result. Optional.</p>

Parameter	Description
	<p>Example:</p> <pre>dsa_query -c "GetComponentInfo" -r "au" "AM*"</pre> <p>1. As an option to print more detailed content.</p> <p>Example:</p> <pre>dsa_query -c GetComponentInfo details=true</pre>

Check CPU usage and RAM usage

Windows

Use the Task Manager or procmon.

Linux and Solaris

```
top
```

AIX

```
topas
```

Check that ds_agent processes or services are running

Windows

Use the Task Manager or procmon.

Linux, AIX, and Solaris

```
ps -ef|grep ds_agent
```

Restart an agent on Linux

```
service ds_agent restart
```

or

```
/etc/init.d/ds_agent restart
```

or

```
systemctl restart ds_agent
```

Some actions require either a `-tenantname` parameter or a `-tenantid` parameter. If execution problems occur when you use the tenant name, try the command using the associated tenant ID.

Restart an agent on Solaris

```
svcadm restart ds_agent
```

Restart an agent on AIX

```
stop agent: stopsrc -s ds_agent
```

```
start agent: startsrc -s ds_agent
```

dsa_scan

If you have Administrator privileges on Windows or root access rights on Linux, you can use the `dsa_scan` command to execute a scan task with specified files or directories, including subdirectories.

`dsa_scan` allows for concurrent execution of up to ten Deep Security Agent instances.

This command ignores the agent's current scan policy on inclusions and exclusions settings (**Policy > Anti-Malware > Inclusion > Manual and Policy > Anti-Malware > Exclusions > Manual**).

To use `dsa_scan`:

On Windows:

1. Open the Command Prompt as an Administrator.
2. Change to the agent's installation directory:

```
cd C:\Program Files\Trend Micro\Deep Security Agent\
```
3. Run the `dsa_scan` command:

```
dsa_scan <option>
```

where `<option>` is one or more options described in ["dsa_scan options" on the next page](#).

On Linux, execute the following command:

```
sudo /opt/ds_agent/dsa_scan <option>
```

where `<option>` is one or more options described in ["dsa_scan options" on the next page](#)

The `dsa_scan` command is not supported on macOS.

dsa_scan options

```
dsa_scan [--target <str>] [--action <str>] [--log <str>]
```

Parameter	Description
<code>--target</code>	<p>File paths or directories with the delimiter " " to separate the input file absolute paths and directories.</p> <p>Example file path and directories: <code>"c:\user data c:\app\config.exe c:\workapps"</code></p> <p>Example command: <code>dsa_scan --target "c:\user data c:\app\config.exe c:\workapps"</code></p>
<code>--action</code>	<p>Optional</p> <p>Supported actions are pass, delete, quarantine.</p> <p>The current agent scan actions of Manual Scan Configuration are applied if the parameter action is not supplied.</p> <p>Example command: <code>dsa_scan --action delete --target "c:\user data,c:\app\config.exe"</code></p>
<code>--log</code>	<p>Optional</p> <p>The absolute file path of an output log file.</p> <p>If this option is not supplied, the scan result outputs to the command-line console.</p> <p>Example output file: <code>"c:\temp\scan.log"</code></p> <p>Example command: <code>dsa_scan --target "c:\users\" --log "c:\temp\scan.log"</code></p>

dsa_scan output

The following table describes the scan status labels that you would encounter after executing the `dsa_scan` command:

Label	Description
Skipped	The scan file size limit was reached.
Infected	The file was detected by the scan engine and the action had been taken.
Warning	The file was detected by the scan engine but it encountered issues on the action taken. Check the error code.

The following is an example scan output:

```

DSA on-demand scan utility
System date/time: 2023/10/12 16:04:10
trace id: 7acf6855-8547-46fc-a58f-9218d108e727
Scanning...
[Skipped] Path: /home/user1/Documents/oversize.zip
[Skipped] Path: /home/user1/Documents/xxx.big
[Infected] Path: /home/user1/Documents/readme, Action: Passed, Malware
Name: EICAR, QuarantineID: 0, Error code: 0
[Infected] Path: /home/user1/Documents/sales.doc, Action: Cleaned, Malware
Name: BRAIN.A, QuarantineID: 0, Error code: 0
[Warning] Path: /home/user1/Documents/po.ppt, Action: Quarantine, Malware
Name: RANSOM.A, QuarantineID: 0, Error code: 5
[Infected] Path: /home/user1/Documents/shipment.zip(po.exe), Action:
Deleted, Spyware Name: BLKFRI.A, QuarantineID: 0, Error code: 0
25 files scanned, 2 skipped in 10 seconds.
4 files out of 25 were infected.
End of Scan.

```

Scan exit codes

The `dsa_scan` command exit codes indicate either the scan success or failure.

Success exit codes

The success exit code indicates the `dsa_scan` utility completed the scan tasks without detecting any issues or viruses or skipping files, as per the following table:

Exit code	Description	Resolution
0	Scan completed and no malware found.	Scan task completed without malware found.
1	Scan completed with at least one malware found.	Check lines labelled as Infected and Warning in the output.
2	Scan completed, no malware found but some files skipped.	Check lines labelled as Skipped in the output.
3	Scan completed, but at least malware found and some files skipped.	Check lines labelled as Infected, Warning, and Skipped in the output.

Fatal exit codes

If the `dsa_scan` utility encountered any fatal errors, the `dsa_scan` broke the scan task and exited with an error code, as per the following table:

Exit code	Description	Resolution
246	The argument string is too long.	The string size limit is 2048 characters. Shorten the target parameter and try again.
247	The Security Platform is shutting down.	The agent is stopping. Try again later.
248	Too many instances.	There cannot be more than ten concurrent <code>dsa_scan</code> running instances. Reduce the number of instances.
249	No permission.	The command requires root on Linux and Administrator on Windows.

Exit code	Description	Resolution
		Enable Allow the Agent to Trigger or Cancel a Manual Scan on the scan policy.
250	Manual Scan Configuration is not set.	Configure the Manual Scan setting on the scan policy.
251	AM feature is not enabled.	Enable the AM feature on the scan policy.
252	The platform is not supported.	The <code>dsa_scan</code> is not supported on the current OS platform.
253	The agent is not running.	Deep Security Agent is not running. Enable the agent or contact the administrator.
254	Invalid parameters.	The input parameters are incorrect.
255	Unexpected error.	Try again later. If the issue persists, contact the administrator.

dsm_c

You can use the `dsm_c` command to configure some settings on the manager and to unlock user accounts.

Note: Some commands may cause Deep Security Manager to restart. After executing the commands, ensure that Deep Security Manager has started again.

dsm_c options

```
dsm_c -action actionname
```

To print help on the command, use the `-h` option: `dsm_c -h`

Some actions require either a `-tenantname` parameter or a `-tenantid` parameter. If execution problems occur when you use the tenant name, try the command using the associated tenant ID. Note that all of the parameters shown in brackets in the following table are mandatory.

Action Name	Description	Usage
<pre>addazureendpoint</pre>	<p>Add an Azure endpoint to the allowed endpoint list. This command requires an <code>ENDPOINT</code> parameter that must be specified in the format <code>https://<fqdn></code>. The allowed endpoint list is used to validate endpoints that are specified when adding an Azure account to Deep Security Manager. If you do not specify any endpoints, then only the default built-in endpoints are allowed.</p> <p>For more on adding an Azure account, see "Add a Microsoft Azure account to Deep Security" on page 665.</p>	<pre>dsm_c -action addazureendpoint -endpoint ENDPOINT</pre>

Action Name	Description	Usage
	<p>Related dsm_c options:</p> <pre>listazureend point and removeazuree ndpoint</pre>	
<code>addcert</code>	Add a trusted certificate.	<code>dsm_c -action addcert -purpose PURPOSE -cert CERT</code>
<code>addregion</code>	Add a private cloud provider region.	<code>dsm_c -action addregion -region REGION -display DISPLAY -endpoint ENDPOINT</code>
<code>changesetting</code>	<p>Change a setting.</p> <p>You must back up your deployment before running the command. Do not use this command unless you understand the effects of the setting. Misconfigurations can make your service unavailable or your data unreadable. Usually, you only use this</p>	<pre>dsm_c -action changesetting -name NAME [-value VALUE -valuefile FILENAME] [- computerid COMPUTERID] [-computername COMPUTERNAME] [-policyid POLICYID] [- policyname POLICYNAME] [-tenantname TENANTNAME -tenantid TENANTID]</pre>

Action Name	Description	Usage
	<p>command if requested by your technical support provider telling you which setting <code>NAME</code> to change. Sometimes this command is required during regular use, in which case the setting is described in that section of the documentation, such as masterkey.</p>	
<code>createinsertstatements</code>	Create insert statements (for export to a different database).	<pre>dsm_c -action createinsertstatements [-file FILEPATH] [-generateDDL] [-databaseType sqlserver oracle] [-maxresultfromdb count] [-tenantname TENANTNAME -tenantid TENANTID]</pre>
<code>diagnostic</code>	<p>Create a diagnostic package for the system.</p> <p>If needed, you can "Increase verbose diagnostic package process"</p>	<pre>dsm_c -action diagnostic [-verbose 0 1] [-tenantname TENANTNAME -tenantid TENANTID]</pre>

Action Name	Description	Usage
	memory" on page 1955.	
<code>disablefipsmode</code>	Disable FIPS mode .	<code>dsm_c -action disablefipsmode</code>
<code>enablefipsmode</code>	Enable FIPS mode .	<code>dsm_c -action enablefipsmode</code>
<code>fullaccess</code>	Give an administrator the full access role.	<code>dsm_c -action fullaccess -username USERNAME [-tenantname TENANTNAME -tenantid TENANTID]</code>
<code>listazureendpoint</code>	List all allowed Azure endpoints. Related <code>dsm_c</code> options: <code>addazureendpoint</code> and <code>removeazureendpoint</code>	<code>dsm_c -action listazureendpoint</code>
<code>listcerts</code>	List trusted certificates.	<code>dsm_c -action listcerts [-purpose PURPOSE]</code>
<code>listregions</code>	List private cloud provider regions.	<code>dsm_c -action listregions</code>
<code>masterkey</code>	Generate, import, export, or use a custom master key to encrypt the: <ul style="list-style-type: none"> • database 	If you already configured a master key during a new install , the installer has completed this setup for you. If you skipped master key creation, and want to configure one now, start with the commands in step 1. Enter all commands in order. To generate a new master key, start with the commands in step 1 and enter all commands in

Action Name	Description	Usage
	<p>password</p> <ul style="list-style-type: none"> • keystore password • personal data <p>If a custom master key is not configured, Deep Security uses a hard-coded seed.</p>	<p>order.</p> <p>See also "Install the manager" on page 443 for details on the master key, how it is generated, and what it encrypts.</p> <p>If you configured the master key during an upgrade, back up your database and properties files, and then start with the commands in step 4.</p> <ol style="list-style-type: none"> 1. <code>dsm_c -action masterkey -subaction [generatekmskey -arn AWSARN generatelocalkey]</code> – Generate the master key using either the Amazon Resource Name (ARN) of a Key Management System (KMS) key, or a local environment variable named <code>LOCAL_KEY_SECRET</code>. If using the local environment variable on a multi-node Deep Security Manager, it must be configured on all nodes at the system-level (not user-level), and must include, at a minimum: <ul style="list-style-type: none"> • a capital letter • a lower cased letter • a number • a special character • 8-64 characters <p>Permissions and reliable network access to KMS or <code>LOCAL_KEY_SECRET</code> are required by Deep Security Manager if you configure the master key. The manager uses them to encrypt and decrypt the master key during use. If they temporarily cannot be reached, Deep Security Manager is unable to decrypt required data and the service is unavailable.</p>

Action Name	Description	Usage
		<p>Symptoms can include intermittent event logs and alerts for restart failures and various other errors.</p> <p>2. <code>dsm_c -action masterkey -subaction export -file FILEPATH</code> – Export the master key to a password-encrypted file for backup. You will be prompted for the password.</p> <p>You must back up the master key by exporting it to a safe location. If the master key is lost or destroyed and you do not have a backup, all encrypted data becomes unreadable. If that happens, you must reinstall Deep Security Manager, all relays, and all agents/appliances. If the key is stolen, security of your Deep Security deployment is compromised. Some compliance regulations such as General Data Protection Regulation (GDPR) in Europe may require you by law to notify law enforcement of personal data breaches within 72 hours, and noncompliance can result in fines. Consult your lawyer for more information.</p> <p>To verify your backup for disaster recovery, you can test it by importing the master key:</p> <p><code>dsm_c -action masterkey -subaction [importkmskey -file FILEPATH -arn AWSARN importlocalkey -file FILEPATH]</code> – Import a backup of the master key. This can be useful either for disaster recovery of a corrupted key, or to migrate the master key to another KMS. Before you run this command, you must delete the existing</p>

Action Name	Description	Usage
		<p>master key from the primary tenant (T0) database.</p> <p>For example, you might enter the SQL command:</p> <pre data-bbox="829 512 1458 684">delete from systemsettings where uniquekey = 'settings.configuration.keyEncryptingKey'</pre> <p>3. <code>dsm_c -action masterkey -subaction encryptproperties</code> – Use the master key to encrypt keystore and database passwords in <code>dsm.properties</code> and <code>configuration.properties</code>. You must restart Deep Security Manager for this setting to take effect.</p> <p>4. <code>dsm_c -action masterkey -subaction encrypttenantkey -tenantid [all TENANTNUM]</code> – If you have a multi-tenant deployment, use the master key to encrypt existing tenant key seeds. Tenant key seeds derive subkeys that you can use in the next step. You can execute this command multiple times (this does not apply additional layers of encryption to an already encrypted seed).</p> <p>Optionally, to apply encryption only to new tenants while slowly rolling out to each existing tenant, you can start by executing the following command:</p> <pre data-bbox="829 1688 1458 1814">dsm_c -action changesetting -name settings.configuration.encryptTenantKeyForNewTenants -value true</pre>

Action Name	Description	Usage
		<p>If you only have one (primary) tenant in the environment, <code>tenantid</code> can be either <code>all</code> or <code>0</code>.</p> <ol style="list-style-type: none"> <code>dsm_c -action masterkey -subaction encryptpii -tenantid [all TENANTNUM]</code> – If you have a multi-tenant deployment, use each tenant's key to encrypt their administrators' and contacts' personal data in the database. If you only have one (primary) tenant in the environment, <code>tenantid</code> can be either <code>all</code> or <code>0</code>. <code>dsm_c -action masterkey -subaction encryptdsmprivatekey -tenantid [all TENANTNUM]</code> – Use the master key to encrypt the private key used for activation and other agent-manager communications via SSL/TLS. If you only have one (primary) tenant in the environment, <code>tenantid</code> can be either <code>all</code> or <code>0</code>. <code>dsm_c -action masterkey -subaction isconfigured</code> – Check to see whether or not the master key was created.
<code>removeazureendpoint</code>	<p>Remove an Azure endpoint from allowed endpoint list.</p> <p>You can only remove endpoints added using the <code>dsm_c -action addazureendpoint</code> command.</p>	<pre>dsm_c -action removeazureendpoint - endpoint ENDPOINT</pre>

Action Name	Description	Usage
	<p>Default built-in endpoints cannot be removed.</p> <p>Related dsm_c options:</p> <pre>addazureendp oint and listazureend point</pre>	
<code>removecert</code>	Remove a trusted certificate.	<code>dsm_c -action removecert -id ID</code>
<code>removereigion</code>	Remove a private cloud provider region.	<code>dsm_c -action removereigion -region REGION</code>
<code>resetcounters</code>	Reset counter tables to an empty state.	<code>dsm_c -action resetcounters [-tenantname TENANTNAME -tenantid TENANTID]</code>
<code>script</code>	Perform batch processing of dsm_c commands in a script file.	<code>dsm_c -action script -scriptfile FILEPATH [-tenantname TENANTNAME -tenantid TENANTID]</code>
<code>setports</code>	Set Deep Security Manager port(s) .	<code>dsm_c -action setports [-managerPort port] [-heartbeatPort port]</code>
<code>trustdirectorycert</code>	Trust the certificate of a directory.	<code>dsm_c -action trustdirectorycert -directoryaddress DIRECTORYADDRESS -directoryport DIRECTORYPORT [-username USERNAME] [-password PASSWORD] [-tenantname TENANTNAME -tenantid TENANTID]</code>

Action Name	Description	Usage
unlockout	Unlock a user account.	<pre>dsm_c -action unlockout -username USERNAME [-newpassword NEWPASSWORD] [-disablemfa] [-tenantname TENANTNAME -tenantid TENANTID]</pre>
upgradetasks	Runs the upgrade task actions which may be required as part of an in-service upgrade.	<pre>dsm_c -action upgradetasks [-listtasksets] [-listtasks -taskset UPGRADE_TASK_SET [-force]] [-tenantlist] [-tenantsummary] [-run -taskset UPGRADE_TASK_SET [-force] [-filter REGULAR_EXPRESSION]] [-showrollbackinfo -task TASKNAME] [-purgehistory [-task TASKNAME]] [-showhistory [-task TASKNAME]] [-tenantname TENANTNAME -tenantid TENANTID]</pre> <ul style="list-style-type: none"> • <code>[-listtasksets]</code>: List sets of tasks for the system as a whole or the tenant specified by <code>-tenantname</code>. • <code>[-listtasks -taskset UPGRADE_TASK_SET [-force]]</code>: List the modifications to run. Include <code>-force</code> to list all tasks. • <code>[-tenantlist]</code>: Shows the version of outstanding upgrade actions for the specified tenant. • <code>[-tenantsummary]</code>: Shows a summary of the tenants that are not up to date. • <code>[-run -taskset UPGRADE_TASK_SET [-force] [-filter REGX]]</code>: Run the upgrade actions for each tenant. Include <code>-force</code> to run all tasks even if they have already been done. Include <code>-filter</code> to limit the actions to a regular expression. • <code>[-showrollbackinfo -task TASKNAME]</code>: Shows rollback information for the specified

Action Name	Description	Usage
		<p>task. One tenant or all tenants can be shown.</p> <ul style="list-style-type: none"> <code>[-purgehistory [-task TASKNAME]]</code>: Purge the history for the tenant specified and the task specified. If no tenant or task is specified, all items are matched. <code>[-showhistory [-task TASKNAME]]</code>: Show the history for the tenant specified and the task specified. If no tenant or task specified, all items are matched.
<code>versionget</code>	View information about the current software version, the database schema version, or both.	<code>dsm_c -action versionget [-software] [-dbschema]</code>
<code>viewsetting</code>	View a setting value.	<code>dsm_c -action viewsetting -name NAME [-computerid COMPUTERID] [-computername COMPUTERTNAME] [-policyid POLICYID] [-policyname POLICYNAME] [-tenantname TENANTNAME -tenantid TENANTID]</code>

Return codes

The `dsm_c` command returns an integer value that indicates whether or not the command has executed successfully. The following values can be returned:

- `0`: Successful execution.
- `-1`: Failure of an unknown nature, such as corrupt software installation.
- `1`: Failure during execution, such as the database is not currently accessible.
- `2`: Invalid arguments were provided.

Use the Deep Security API to automate tasks

Deep Security 11.1 and higher have a new RESTful API that enables you to automate the provisioning and maintenance of security via Deep Security. Go to the [Deep Security Automation Center](#) to download the SDKs in the language of your choice and learn how to use the API:

- API Reference
- Task-oriented guides with ample code examples
- Support resources

The API is continuously updated with new features and improvements. When you start new automation projects, if the new API meets your needs you should use it to benefit from continued support and maintenance in the long term.

To get started with the API, see the [First Steps Toward Deep Security Automation](#) guide in the Deep Security Automation Center.

Legacy REST and SOAP APIs

Note: The REST and SOAP APIs that were provided before Deep Security 11.1 have not changed. They have been deprecated, so new features will not be added but the existing API functionality will continue to function as usual.

Deep Security still includes the legacy REST and SOAP APIs. For guidance on using them, see the following guides on the Deep Security Automation Center:

- [Transition from the SOAP API](#)
- [Use the Legacy REST API](#)

The following sections explain how to use Deep Security Manager to accomplish tasks that are related to using the SOAP and REST API. For more information about when you need to perform these tasks, see the guides listed above.

Enable the Status Monitoring API (optional)

To use status monitoring with the legacy REST API, you must enable it. The API is disabled by default as it does not require authentication.

1. On Deep Security Manager, go to **Administration > System Settings > Advanced**.
2. In the Status Monitoring API section, select **Enabled**, then click **Save**.

Create a Web Service user account

Create a role for Web Service-only access, and assign it to a new user.

1. On Deep Security Manager, go to **Administration > User Management > Roles**.
2. Click **New**.
3. Deselect the **Allow Access to Deep Security Manager User Interface** check box and select the **Allow Access to Web Service API** check box.
4. When all other configuration is complete, click **Save**.
5. Go to **Administration > User Management > Users** and click **New**.
6. Create a new user for use only with the Web Service API. Assign the new Role previously created to this user.

Make note of the new user account user name and password.

Schedule Deep Security to perform tasks

Deep Security has many tasks that you might want to perform automatically on a regular basis. Scheduled tasks are useful when deploying Deep Security in your environment and also later, to keep your system up to date and functioning smoothly. They are especially useful for running scans on a regular basis during off-peak hours.

Tip: You can automate scheduled task creation and configuration using the Deep Security API. For examples, see the [Maintain Protection Using Scheduled Tasks](#) guide in the Deep Security Automation Center.

Create scheduled tasks

To set up a scheduled task in the Deep Security Manager, click **Administration > Scheduled Tasks > New**. This opens the "New Scheduled Task Wizard", which takes you through the steps to create a scheduled task.

Check for Security Updates: Regularly check for security updates and import them into Deep Security when they are available. For most organizations, performing this task once daily is ideal.

Note: With Deep Security 11.0 Update 2 or later, the "Check for Security Updates" task ignores offline hosts that have been uncommunicative for 30 days or more.

Check for Software Updates: Regularly check for Deep Security Agent software updates and download them when they are available.

Discover Computers: Periodically check for new computers on the network by scheduling a Discovery operation. You will be prompted for an IP range to check and asked to specify which computer group the new computer will be added to. This task is useful for discovering computers that are not part of your cloud connector.

Generate and Send Report: Automatically generate reports and optionally have them emailed to a list of users.

Scan Computers for Integrity Changes: Causes the Deep Security Manager to perform an Integrity Scan to compare a computer's current state against its baseline.

Scan computers for Malware: Schedules a Malware Scan. The configuration of the scan is specified on the Policy or Computer Editor > Anti-Malware page for each computer. For most organizations, performing this task once weekly (or according to your organization's policies) is ideal. When you configure this task, you can specify a timeout value for the scan. The timeout option is available for daily, weekly, monthly, and once-only scans. It is not available for hourly scans. When a scheduled malware scan is running and the timeout limit has been reached, any tasks that are currently running or pending are canceled.

Tip: When a **Scan Computers for Malware** task times out, the next scheduled scan starts over from the beginning (it does not start where the previous scan ended). The goal is to perform a complete scan, so consider making some configuration changes if your scans regularly reach the timeout limit. You can change the malware scan configuration to add some exceptions, or extend the timeout period.

Scan Computers for Open Ports: Schedule periodic port scans on one or more computers. You can specify individual computers or all computers belonging to a particular computer group. Deep Security Manager will scan the port numbers defined on the Scanning tab in the Policy or Computer Editor > Settings page.

Scan Computers for Recommendations: Causes the Deep Security Manager to scan the computer(s) for common applications and then make recommendations based on what is detected. Performing regular recommendation scans ensures that your computers are protected by the latest relevant rule sets and that those that are no longer required are removed. If you

have set the "Automatically implement Recommendations" option for each of the three protection modules that support it, Deep Security will assign and unassign rules that are required. If rules are identified that require special attention, an alert will be raised to notify you. For most organizations, performing this task once a week is ideal.

Note: Recommendation Scans can be CPU-intensive, so when scheduling Recommendation Scans, it is best practice to set the task by group (for example, per policy or for a group of computers, no more than 1,000 machines per group) and spread it in different days (for example, database server scans scheduled every Monday; mail server scans scheduled every Tuesday, and so on). Schedule Recommendation Scans more frequently for systems that change often.

Scheduled Agent Upgrade Task: Schedules an agent upgrade. You can reference [Upgrade best practices for agents](#) to help you determine the best schedule for agent upgrades.

Tip: You can configure this task to upgrade the agent to the latest version, or one of the two versions before it. The exact version the agent will upgrade to is determined when the scheduled task is executed. The examples provided within the scheduled task configuration wizard are based on the Red Hat Enterprise Linux agent versions.

Send Outstanding Alert Summary: Generate an email listing all outstanding (unresolved) alerts.

Send Policy: Regularly check for and send updated policies. Scheduled updates allow you to follow an existing change control process. Scheduled tasks can be set to update machines during maintenance windows, off hours, etc.

Synchronize Cloud Account: Synchronize the Computers list with an added cloud account. (Only available if you have added a cloud account to the Deep Security Manager. Applies to Azure and vCloud accounts only. Not available for other cloud account types such as AWS and Google Cloud Platform (GCP).)

Synchronize Directory: Synchronize the Computers list with an added LDAP directory. (Only available if you have added an LDAP directory to the Deep Security Manager.)

Synchronize Users/Contact: Synchronize the Users and Contacts lists with an added Active Directory. (Only available if you have added an Active Directory to the Deep Security Manager.)

Synchronize VMware vCenter: Synchronize the Computers list with an added VMware vCenter. (Only available if you have added a VMware vCenter to the Deep Security Manager.)

Enable or disable a scheduled task

Existing scheduled tasks can be enabled or disabled. For example, you might want to temporarily disable a scheduled task while you perform certain administrative duties during which you don't want any activity to occur. The control to enable or disable a scheduled task is on the General tab of the Task's Properties window.

Set up scheduled reports

Scheduled reports are scheduled tasks that periodically generate and distribute reports to users and contacts (this feature used to be named "Recurring Reports"). Most of the options are identical to those for single reports, with the exception of the time filter.

Tip: To generate a report on specific computers from multiple computer groups, create a user who has viewing rights only to the computers in question and then either create a scheduled task to regularly generate an "All Computers" report for that user or sign in as that user and run an "All Computers" report. Only the computers to which that user has viewing rights will be included in the report.

Automatically perform tasks when a computer is added or changed (event-based tasks)

Note: In this article, references to protecting virtual machines apply only to Deep Security On-Premise software installations.

Event-based tasks let you monitor protected computers for specific events and perform tasks based on certain conditions.

Create an event-based task

In Deep Security Manager, click **Administration > Event-Based Tasks > New**. The wizard that appears will guide you through the steps of creating a new task. You will be prompted for different information depending on the type of task.

Edit or stop an existing event-based task

To change the properties for an existing event-based task, go to click **Administration > Event-Based Tasks**. Select the event-based task from the list and click **Properties**.

Events that you can monitor

- **Computer Created (by System):** A computer being added to the manager during synchronization with an Active Directory or Cloud Provider account, or the creation of a virtual machine on a managed ESXi server running a virtual appliance.
- **Computer Moved (by System):** A virtual machine being moved from one vApp to another within the same ESXi, or a virtual machine on an ESXi being move from one datacenter to another or from one ESXi to another (including from an unmanaged ESXi server to a managed ESXi server running a virtual appliance.)
- **Agent-Initiated Activation:** An agent is activated using agent-initiated activation.
- **IP Address Changed:** A computer has begun using a different IP.
- **NSX Security Group Changed:** The following situations will trigger this event (the event will be recorded on each affected VM):
 - A VM is added to a group that is (indirectly) associated with the NSX Deep Security Service Profile
 - A VM is removed from an NSX Group that is associated with the NSX Deep Security Service Profile
 - An NSX Policy associated with the NSX Deep Security Service Profile is applied to an NSX Group
 - An NSX Policy associated with the NSX Deep Security Service Profile is removed from an NSX Group
 - An NSX Policy is associated with the NSX Deep Security Service Profile
 - An NSX Policy is removed from the NSX Deep Security Service Profile
 - An NSX Group that is associated with an NSX Deep Security Service Profile changes name
- **Computer Powered On (by System):** Enables users to trigger activation by the VMware Virtual Machine power on event.

Note: The Computer Powered On event is only compatible with virtual machines hosted on ESX environments in VMWare. Use this event cautiously because if a large number of computers are turned on at the same time, this event could cause a slowdown.

Conditions

You can require specific match conditions to be met in order for a task to be carried out. For example, you might require an AWS 'tag' of `ProductionSystem` to be present in an Amazon EC2 instance in order for the **Activate Computer** action (see ["Actions" on page 1774](#), below) to occur on it.

When adding conditions:

- Click the "plus" button to add multiple conditions. In a multi-condition setup, ALL conditions must be met for the action to be carried out.
- Use Java regular expression syntax (regex). Some examples of how to use regex are provided in the table below. For details on regex, see <https://docs.oracle.com/javase/6/docs/api/java/util/regex/Pattern.html>.

List of conditions and descriptions of each

- **Cloud Instance Image ID:** AWS cloud instance AMI ID.

Note: This match condition is only available for AWS instances added to the manager through **Computers > Add > Add AWS Account**.

- **Cloud Instance Metadata:** The metadata being matched corresponds to [AWS tags](#), [Azure tags](#), or [GCP labels](#) that have been added to your AWS, Azure, or GCP instances.

Note: This match condition is available for AWS instances and Azure or GCP VMs added to the manager through **Computers > Add > [Add AWS Account, Add Azure Account, or Add GCP Account]**. Metadata currently associated with a computer is displayed on the **Overview** page in its editor window. To define the conditions to match for, you must provide two pieces of information: the metadata key and the metadata value. For example, to match a computer which has a metadata key named **"AlphaFunction"** that has a value of **"DServer"**, you would enter **"AlphaFunction"** and **"DServer"** (without the quotes). If you wanted match more than one possible condition,

you could use regular expressions and enter "AlphaFunction" and ".*Server", or "AlphaFunction" and "D.*".

- **Cloud Instance Security Group Name:** The security group the cloud instance applies to.

Note: This match condition is only available for AWS cloud instances.

- **Cloud Account Name:** The "Display Name" field in the Cloud Account properties window.
- **Cloud Vendor:** The cloud environment vendor of the instance. This condition is used to match on instances from a specific cloud vendor. Currently, you can match on AWS, Azure, and GCP vendors.

Note: Cloud Vendor only works if you added your cloud instances to the manager through **Computers > Add > [Add AWS Account, Add Azure Account, or Add GCP Account]**.

- **Computer Name:** The "Hostname" field in the computer properties window.
- **ESXi Name:** The "Hostname" field of the ESXi server on which the VM computer is hosted.
- **Folder Name:** The name of the folder or directory in which the computer is located in its local environment.

Note: This match condition looks for a match against the name of **any** parent folder of the computer, including the root datacenter for vCenter server integrations. If you add a "*" character to the beginning of the regular expression, the condition must match the name on **all** parent folders. This is particularly useful when combined with negation in a regular expression. For example, if you want to match computers in folders that do not include "Linux" in the folder name, you could use a regular expression like `*^(?!Linux).*`.

- **GCP Network Tag:** [Network tags](#) that have been added to GCP VMs.

Note: If the GCP VM has multiple GCP network tags, and a match is found on *any* one of them, the VM is considered as matched.

- **NSX Security Group Name:** The list of potential groups in this condition refers only to NSX Groups associated with NSX Policies associated with the NSX Deep Security Service Profile. The VM may be a member of other NSX Groups but for the purposes of this match, condition it is not relevant.

- **Platform:** The operating system of the computer.
- **vCenter name:** The "Name" field of the computer's vCenter properties that was added to Deep Security Manager.

These next two conditions match True or False conditions:

- **Appliance Protection Available:** A Deep Security Virtual Appliance is available to protect VMs on the ESXi on which the VM is hosted. The VM may or may not be in a "Activated" state.
- **Appliance Protection Activated:** A Deep Security Virtual Appliance is available to protect VMs on the ESXi on which the VM is hosted and the VM is "Activated".

This condition looks for matches to an IP in an IP list:

- **Last Used IP Address:** The current or last known IP address of the computer.

Note: Depending on the source of the new computer, some fields may not be available. For example, "Platform" would not be available for computers added as a result of the synchronization with an Active Directory.

Java regex examples

To match:	Use this:
any string (but not nothing)	.+
empty string (no text)	^\$
Folder Alpha	Folder\ Alpha
FIN-1234	FIN-\d+ or FIN-.*
RD-ABCD	RD-\w+ or RD-.*
AB or ABC or ABCCCCCCCC	ABC*
Microsoft Windows 2003 or Windows XP	.*Windows.*
Red Hat 7 or	.*Red.* .*Linux.*

To match:	Use this:
Some_Linux123	

Actions

The following actions can be taken depending on which of the above events is detected:

- **Activate Computer:** Deep Security protection is activated on the computer.
 - **Delay activation by (minutes):** Activation is delayed by a specified number of minutes.

- **Note:** If the event-based task is intended to apply protection to a VM that is being vMotioned to an ESXi protected by a Deep Security Virtual Appliance, add a delay before activation to allow any pending VMware administrative tasks to complete. The amount of delay varies depending on your environment.

- **Deactivate Computer:** Deep Security protection is deactivated on the computer.
- **Assign Policy:** The new computer is automatically assigned a policy. (The computer must be activated first.)
- **Assign Relay Group:** The new computer is automatically assigned a relay group from which to receive security updates.
- **Assign to Computer Group:** The computer is placed in one of the computer groups on the Computers page.

Order of execution

When using event based tasks, you should create and use conditions that are unique to each task. This is because when identical conditions are encountered, Deep Security will process them in a specific order, and this order does not take into account the number of conditions within a task to rank said tasks against each other.

For example, if the *server01.example.com* computer on a *Windows Server 2012* platform encountered the following event-based tasks:

General	Actions	Conditions
General Information Name: <input type="text" value="Specific EBT"/> Event: <input type="text" value="Agent-Initiated Activation"/> Task Enabled: <input checked="" type="checkbox"/>		
Summary Information Actions: Assign Policy: Windows Server 2012 Conditions: "Computer Name" matches "server.*.example.com" "Platform" matches ".*Windows.*" Description:		
<input type="button" value="OK"/> <input type="button" value="Cancel"/> <input type="button" value="Apply"/>		

General	Actions	Conditions
General Information Name: <input type="text" value="catch-All EBT"/> Event: <input type="text" value="Agent-Initiated Activation"/> Task Enabled: <input checked="" type="checkbox"/>		
Summary Information Actions: Assign Policy: Windows Conditions: "Platform" matches ".*Windows.*" Description:		
<input type="button" value="OK"/> <input type="button" value="Cancel"/> <input type="button" value="Apply"/>		

The event-based task with more conditions is not automatically executed first. Instead, the "Platform" condition is matched twice, and the event-based tasks are executed based on the name of the task and your database type.

- **PostgreSQL:** "a task", "A task", "b task", "B task"
- **Oracle:** "A task", "B task", "a task", "b task" ([ASCIIbetical](#) order)
- **Microsoft SQL Server:** Depends on the locale of the operating system.

However, keep in mind that this order does not stop on the first match, and instead stops on the last match. This, in practice, means that if you're using Oracle, the example above would be assigned a policy by the "catch-All EBT" because using ASCIIbetical order dictates that the "c" in "catch" comes after "S" in "Specific".

To avoid unexpected results, use a specific naming convention for your event-based tasks, such as CamelCase.

Note: The order of task names is actually dictated by what collation scheme you use for the column "name" of the table "scheduledtasks" within your database. For example, Oracle uses

the collation scheme "NLS_COMP:BINARY" and "NLS_SORT:BINARY" as its default collation scheme for all columns, and that sorts task name strings in ASCIIbetical order.

Temporarily disable an event-based task

To prevent an existing event-based task from running, right-click it and then click **Disable**. For example, you may want to temporarily disable an event-based task while you perform certain administrative duties during which you don't want any activity to occur.

To re-enable an event-based task, right-click it and then click **Enable**.

AWS Auto Scaling and Deep Security

You can set up automatic protection in Deep Security for new instances created by AWS Auto Scaling.

Each instance created by Auto Scaling will need to have a Deep Security agent installed on it. There are two ways that you can do this: you can include a pre-installed agent in the EC2 instance used to create the AMI, or you install the agent by including a deployment script in the launch configuration for the AMI. There are pros and cons for each option:

- If you include a pre-installed agent, instances will spin up more quickly because there is no need to download and install the agent software. The downside is that the agent software might not be the latest. To work around this issue, you can enable the [upgrade on activation](#) feature.
- If you use a deployment script to install the agent, it will always get the latest version of the agent software from the Deep Security Manager.

Pre-install the agent

If you have an EC2 instance already configured with a Deep Security Agent, you can use that instance to create the AMI for Auto Scaling. Before creating the AMI, you must deactivate the agent on the EC2 instance and stop the instance:

```
dsa_control -r
```

Note: Don't create an AMI that contains an activated agent. Each agent must be activated individually.

Each new EC2 instance created by Auto Scaling needs to have its agent activated and a policy applied to it, if it doesn't have one already. There are two ways to do this:

- You can create a deployment script that activates the agent and optionally applies a policy. Then add the deployment script to the AWS launch configuration so that it is run when a new instance is created. For instructions, see the "Install the Agent with a deployment script" section below, but omit the section of the deployment script that gets and installs the agent. You will only need the `dsa_control -a` section of the script.

Note: For the deployment scripts to work, agent-initiated communication must be enabled on your Deep Security Manager. For details on this setting, see ["Activate and protect agents using agent-initiated activation and communication" on page 1460](#)

- You can set up an event-based task in Deep Security Manager that will activate the agent and optionally apply a policy when an instance is launched and the "Computer Created (By System)" event occurs.

Install the agent with a deployment script

Deep Security provides the ability to generate customized deployment scripts that you can run when EC2 instances are created. If the EC2 instance does not contain a pre-installed agent, the deployment script should install the agent, activate it, apply a policy, and optionally assign the machine to a computer group and relay group.

Tip: You can generate deployment scripts to automate the agent installation using the Deep Security API. For more information, see [Generate an agent deployment script](#).

In order for the deployment script to work:

- You must create AMIs from machines that are stopped.
- Agent-initiated communication must be enabled on your Deep Security Manager. For details on this setting, see ["Activate and protect agents using agent-initiated activation and communication" on page 1460](#).

To set up automatic protection for instances using a deployment script:

1. Sign in to Deep Security Manager.
2. From the **Support** menu in the top right-hand corner, select **Deployment Scripts**.
3. Select your platform.
4. Select **Activate Agent automatically after installation**.

5. Select the appropriate **Security Policy**, **Computer Group** and **Relay Group**.
6. Click **Copy to Clipboard**.
7. Go to the AWS launch configuration, expand **Advanced Details** and paste the deployment script into **User Data**.

The screenshot shows the 'Create Launch Configuration' page in the AWS Management Console, specifically the '3. Configure details' step. The 'Advanced Details' section is expanded, and the 'User data' field is highlighted with a red border. The 'User data' field contains the following PowerShell script:

```
#!/usr/bin/env bash
wget
https://app.deepsecurity.trendmicro.com:443/software/agent/amzn1/
x86_64/ -O /tmp/agent.rpm --no-check-certificate --quiet
rpm -ihv /tmp/agent.rpm
```

Other visible options include:

- Name:** (empty text input)
- Purchasing option:** Request Spot Instances
- IAM role:** None
- Monitoring:** Enable CloudWatch detailed monitoring
- Kernel ID:** Use default
- RAM Disk ID:** Use default
- User data:** As text As file Input is already base64 encoded
- IP Address Type:** Only assign a public IP address to instances launched in the default VPC and subnet. (default)
- Link to VPC:**

Note: If you are encountering issues getting the PowerShell deployment script to run on a Microsoft Windows-based AMI, the issues may be caused by creating the AMI from a running instance. AWS supports creating AMIs from running instances, but this option disables ALL of the `Ec2Config` tasks that would run at start time on any instance created from the AMI. This behavior prevents the instance from attempting to run the PowerShell script.

Note: When you build an AMI on Windows, you need to re-enable user-data handling manually or as part of your image-building process. The user-data handling only runs in the first boot of the Windows base AMI unless it's explicitly told otherwise (it's disabled during the

initial boot process), so instances built from a custom AMI won't run user-data unless the feature is re-enabled. [Configuring a Windows Instance Using the EC2Config Service](#) has a detailed explanation and instructions for how to reset the feature or ensure it's not disabled on first boot. The easiest mechanism is to include `<persist>true</persist>` in your user data, providing that you have EC2Config version 2.1.10 or later.

Delete instances from Deep Security as a result of Auto Scaling

After you have added an AWS Account in the Deep Security Manager, instances that no longer exist in AWS as a result of Auto Scaling will be automatically removed from the Deep Security Manager.

See ["About adding AWS accounts" on page 640](#) for details on adding an AWS account.

Azure virtual machine scale sets and Deep Security

Azure virtual machine scale sets (VMSS) provide the ability to deploy and manage a set of identical VMs. The number of VMs can increase or decrease automatically based on configurable scaling rules. For more information, see [What are virtual machine scale sets in Azure?](#)

You can set up your VMSS to include a base VM image that has the Deep Security Agent pre-installed and pre-activated. As the VMSS scales up, the new VM instances in the scale set automatically include the agent.

To add the agent to your VMSS:

- ["Step 1: \(Recommended\) Add your Azure account to Deep Security Manager" on the next page](#)
- ["Step 2: Prepare a deployment script" on the next page](#)
- ["Step 3: Add the agent through a custom script extension to your VMSS instances" on page 1781](#)

Step 1: (Recommended) Add your Azure account to Deep Security Manager

When you add your Azure account to Deep Security Manager, all the Azure instances created under that account are loaded into Deep Security Manager and appear under **Computers**. The instances appear regardless of whether they have an agent installed or not. The ones that do not include an agent have a **Status** of **No Agent/Appliance**. After you install and activate the agent on them, their **Status** changes to **Managed (Online)**.

If the scale set is manually or automatically scaled up after adding your Azure account, Deep Security detects the new Azure instances and adds them to its list under **Computers**. Similarly, if the scale set is scaled down, the instances are removed from view. Thus, Deep Security Manager always shows the current list of available Azure instances in your scale set.

However, if you do not add your Azure account to Deep Security Manager, but instead add individual Azure instances using another method, then Deep Security does not detect any scaling down that might occur, and does not remove the non-existent Azure instances from its list. To prevent an ever-expanding list of Azure VMs in your Deep Security Manager, and to always show exactly which Azure instances are available in your scale set at any one time, it is highly recommended that you add your Azure account to Deep Security Manager.

For instructions on adding your Azure account, see ["Add a Microsoft Azure account to Deep Security" on page 665](#).

Step 2: Prepare a deployment script

In Deep Security Manager, prepare a deployment script from Deep Security Manager. For instructions, see ["Use deployment scripts to add and protect computers" on page 1790](#). This deployment script will be referenced in a custom script extension that you'll configure next.

Note: To run a custom script with the following VMSS script, the script must be stored in Azure Blob storage or in any other location accessible through a valid URL. For instructions on how to upload a file to Azure Blob storage, see [Perform Azure Blob storage operations with Azure PowerShell](#).

Step 3: Add the agent through a custom script extension to your VMSS instances

Below are a couple of examples on how to use PowerShell to add the agent.

- [Example 1](#) shows how to create a new VMSS that includes the agent
- [Example 2](#) shows how to add the agent to an existing VMSS

Both examples:

- use the [Add-AzureRmVmssExtension cmdlet](#) to add an extension to the VMSS
- use Azure PowerShell version 5.1.1

Note: For instructions on creating a new VMSS using PowerShell cmdlets, refer to [this Microsoft tutorial](#). For the Linux platform, see <https://github.com/Azure/custom-script-extension-linux>.

Example 1: Create a new VMSS that includes the agent

```
$resourceGroupName = <The resource group of the VMSS>
$vmssname = <The name of the VMSS>

# Create ResourceGroup
New-AzureRmResourceGroup -ResourceGroupName $resourceGroupName -Location
EastUS

# Create a config object
$vmssConfig = New-AzureRmVmssConfig `
    -Location EastUS `
    -SkuCapacity 2 `
    -SkuName Standard_DS2 `
    -UpgradePolicyMode Automatic
```

Trend Micro Deep Security On-Premise 20

```
# Define the script for your Custom Script Extension to run on the Windows Platform
```

```
$customConfig = @{
```

```
    "fileUri" = ("A URL of your copy of deployment script, ex. deploymentscript.ps1");
```

```
    "commandToExecute" = "powershell -ExecutionPolicy Unrestricted -File deploymentscript.ps1"
```

```
}
```

```
# Define the script for your Custom Script Extension to run on the Linux Platform
```

```
#$customConfig = @{
```

```
# "fileUri" = ("A URL of your copy of deployment script, ex. deploymentscript.sh");
```

```
# "commandToExecute" = "bash deploymentscript.sh"
```

```
#}
```

```
# The section is required only if deploymentscript has been located within Azure StorageAccount
```

```
$storageAccountName = <StorageAccountName if deploymentscript is located in Azure Storage>
```

```
$key = (Get-AzureRmStorageAccountKey -Name $storageAccountName -ResourceGroupName $resourceGroupName).Value[0]
```

```
$protectedConfig = @{
```

```
    "storageAccountName" = $storageAccountName;
```

```
    "storageAccountKey" = $key
```

```
}
```

```
# Use Custom Script Extension to install Deep Security Agent (Windows)
```

```
Add-AzureRmVmssExtension -VirtualMachineScaleSet $vmssConfig `
```

Trend Micro Deep Security On-Premise 20

```
-Name "customScript" `
-Publisher "Microsoft.Compute" `
-Type "CustomScriptExtension" `
-TypeHandlerVersion 1.8 `
-Setting $customConfig `
-ProtectedSetting $protectedConfig

# Use Custom Script Extension to install Deep Security Agent (Linux)
#Add-AzureRmVmssExtension -VirtualMachineScaleSet $vmssConfig `
# -Name "customScript" `
# -Publisher "Microsoft.Azure.Extensions" `
# -Type "customScript" `
# -TypeHandlerVersion 2.0 `
# -Setting $customConfig `
# -ProtectedSetting $protectedConfig

# Create a public IP address
# Create a frontend and backend IP pool
# Create the load balancer
# Create a load balancer health probe on port 80
# Create a load balancer rule to distribute traffic on port 80
# Update the load balancer configuration
# Reference a virtual machine image from the gallery
# Set up information for authenticating with the virtual machine
# Create the virtual network resources
# Attach the virtual network to the config object
```

```
# Create the scale set with the config object (this step might take a few minutes)
```

```
New-AzureRmVmss `
    -ResourceGroupName $resourceGroupName `
    -Name $vmssname `
    -VirtualMachineScaleSet $vmssConfig
```

Example 2: Add the agent to an existing VMSS

```
$resourceGroupName = <The resource group of the VMSS>
```

```
$vmssname = <The name of the VMSS>
```

```
# Get the VMSS model
```

```
$vmssobj = Get-AzureRmVmss -ResourceGroupName $resourceGroupName -
VMSScaleSetName $vmssname
```

```
# Show model data if you prefer
```

```
# Write-Output $vmssobj
```

```
# Define the script for your Custom Script Extension to run on the Windows platform
```

```
$customConfig = @{
```

```
    "fileUri" = ("A URL of your copy of deployment script, ex.
    deploymentscript.ps1");
```

```
    "commandToExecute" = "powershell -ExecutionPolicy Unrestricted -File
    deploymentscript.ps1"
```

```
}
```

```
# Define the script for your Custom Script Extension to run on the Linux platform
```

Trend Micro Deep Security On-Premise 20

```
#$customConfig = @{
# "fileUri" = (,"A URL of your copy of deployment script, ex.
deploymentscript.sh");
# "commandToExecute" = "bash deploymentscript.sh"
#}

# The section is required only if deploymentscript has been located within
Azure StorageAccount

$storageAccountName = <StorageAccountName if deploymentscript is locate in
Azure Storage>

$key= (Get-AzureRmStorageAccountKey -Name $storageAccountName -
ResourceGroupName $resourceGroupName).Value[0]

$protectedConfig = @{
    "storageAccountName" = $storageAccountName;
    "storageAccountKey" = $key
}

# Use Custom Script Extension to install Deep Security Agent (Windows)
$newvmssobj = Add-AzureRmVmssExtension `
    -VirtualMachineScaleSet $vmssobj `
    -Name "customScript" `
    -Publisher "Microsoft.Compute" `
    -Type "CustomScriptExtension" `
    -TypeHandlerVersion 1.8 `
    -Setting $customConfig `
    -ProtectedSetting $protectedConfig

# Use Custom Script Extension to install Deep Security Agent (Linux)
#$newvmssobj = Add-AzureRmVmssExtension `
```

Trend Micro Deep Security On-Premise 20

```
# -VirtualMachineScaleSet $vmssobj `
# -Name "customScript" `
# -Publisher "Microsoft.Azure.Extensions" `
# -Type "customScript" `
# -TypeHandlerVersion 2.0 `
# -Setting $customConfig `
# -ProtectedSetting $protectedConfig

# Update the virtual machine scale set model
Update-AzureRmVmss -ResourceGroupName $resourceGroupName -name $vmssname -
VirtualMachineScaleSet $newvmssobj -Verbose

# Get Instance ID for all instances in this VMSS, and decide which
instance you'd like to update

# Get-AzureRmVmssVM -ResourceGroupName $resourceGroupName -VMScaleSetName
$vmssname

# Now start updating instances

# If upgradePolicy is Automatic in the VMSS, do NOT execute the next
command Update-AzureRmVmssInstance. Azure will auto-update the VMSS.

# There's no PowerShell command to update all instances at once. But you
could refer to the output of Update-AzureRmVmss, and loop all instances
into this command.

Update-AzureRmVmssInstance -ResourceGroupName $resourceGroupName -
VMScaleSetName $vmssname -InstanceId 0
```

GCP auto scaling and Deep Security

You can set up automatic protection in Deep Security for new GCP VM instances created through GCP [managed instance groups \(MIGs\)](#) to support [auto scaling](#).

Each GCP VM instance created through a MIG will need to have a Deep Security agent installed on it. There are two ways that you can do this: you can include a pre-installed agent in the GCP VM instance used to create the instance template, or you can install the agent by including a deployment script in the [instance template](#) for the image. There are pros and cons for each option:

- If you include a pre-installed agent, instances will spin up more quickly because there is no need to download and install the agent software. The downside is that the agent software might not be the latest. To work around this issue, you can enable the [upgrade on activation](#) feature.
- If you use a deployment script to install the agent, it will always get the latest version of the agent software from the Deep Security Manager.

Pre-install the agent

If you have a GCP VM instance already configured with a Deep Security Agent, you can use that instance to create the instance template for the MIG. Before creating the instance template, you must deactivate the agent on the GCP VM instance and stop the instance:

```
dsa_control -r
```

Each new GCP VM instance created by the MIG needs to have its agent activated and a policy applied to it, if it doesn't have one already. There are two ways to do this:

- You can create a deployment script that activates the agent and optionally applies a policy. Then add the deployment script to the GCP instance template so that it is run when a new instance is created. For instructions, see the ["Install the agent with a deployment script" on the next page](#) section below, but omit the section of the deployment script that gets and installs the agent. You will only need the `dsa_control -a` section of the script.

Note: For the deployment scripts to work, agent-initiated communication must be enabled on your Deep Security Manager. For details on this setting, see ["Activate and protect agents using agent-initiated activation and communication" on page 1460](#).

- You can set up an event-based task in Deep Security Manager that will activate the agent and optionally apply a policy when an instance is launched and the "Computer Created (By System)" event occurs.

Install the agent with a deployment script

Deep Security provides the ability to generate customized deployment scripts that you can run when GCP VM instances are created. If the GCP VM instance does not contain a pre-installed agent, the deployment script should install the agent, activate it, apply a policy, and optionally assign the machine to a computer group and relay group.

Tip: You can generate deployment scripts to automate the agent installation using the Deep Security API. For more information, see [Generate an agent deployment script](#).

In order for the deployment script to work:

- You must create images from machines that are stopped.
- Agent-initiated communication must be enabled on your Deep Security Manager. For details on this setting, see "[Activate and protect agents using agent-initiated activation and communication](#)" on page 1460.

To set up automatic protection for instances using a deployment script:

1. Sign in to Deep Security Manager.
2. From the **Support** menu in the top right-hand corner, select **Deployment Scripts**.
3. Select your platform.
4. Select **Activate Agent automatically after installation**.
5. Select the appropriate **Security Policy**, **Computer Group** and **Relay Group**.
6. Click **Copy to Clipboard**.
7. Go to the GCP instance templates, expand **Management, security, disks, networking**,

sole tenancy and paste the deployment script into **Startup script**.

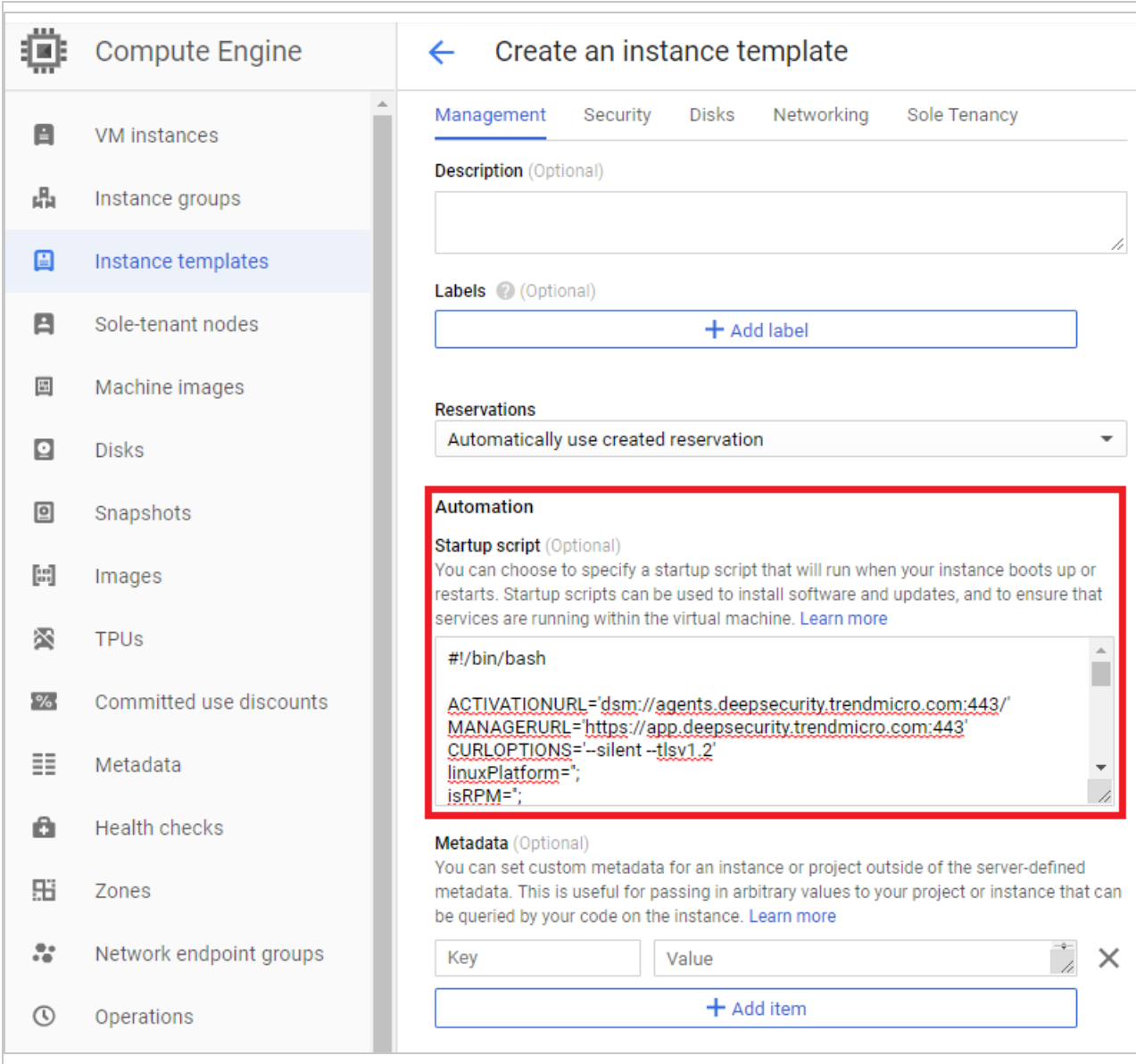

The screenshot shows the 'Create an instance template' page in the Google Cloud Platform console. The left sidebar is titled 'Compute Engine' and lists various resources. The main content area is titled 'Create an instance template' and has tabs for 'Management', 'Security', 'Disks', 'Networking', and 'Sole Tenancy'. The 'Automation' section is highlighted with a red box and contains the following content:

Automation

Startup script (Optional)
 You can choose to specify a startup script that will run when your instance boots up or restarts. Startup scripts can be used to install software and updates, and to ensure that services are running within the virtual machine. [Learn more](#)

```
#!/bin/bash
ACTIVATIONURL='dsm://agents.deepsecurity.trendmicro.com:443/'
MANAGERURL='https://app.deepsecurity.trendmicro.com:443'
CURLOPTS='--silent --tlsv1.2'
linuxPlatform='';
isRPM='';
```

Metadata (Optional)
 You can set custom metadata for an instance or project outside of the server-defined metadata. This is useful for passing in arbitrary values to your project or instance that can be queried by your code on the instance. [Learn more](#)

Below the metadata section, there are input fields for 'Key' and 'Value', and a '+ Add item' button.

Delete instances from Deep Security as a result of GCP MIGs

After you have added a GCP account in Deep Security Manager, instances that no longer exist in GCP as a result of Managed Instance Group will be automatically removed from the Deep Security Manager.

See ["Add a Google Cloud Platform account" on page 677](#) for details on adding a GCP account.

Use deployment scripts to add and protect computers

Adding a computer to your list of protected resources in Deep Security and implementing protection is a multi-step process. Almost all of these steps can be performed from the command line on the computer and can therefore be scripted. The Deep Security Manager contains a deployment script writing assistant which can be accessed from the **Support** menu.

The deployment scripts generated through Deep Security Manager do the following:

- install the Deep Security Agent on a chosen platform
- activate the agent
- assign a policy to the agent

Generate a deployment script

1. Before you begin:
 - a. Make sure you have imported the agent software to Deep Security Manager. See ["Get Deep Security Agent software" on page 497](#) for details.
 - b. Make sure your agent version control settings are configured as desired. See ["Configure agent version control" on page 1442](#) for details.
 - c. Make sure you have enabled agent-initiated activation (AIA). AIA is required if you want your deployment script to activate the agent after installation. See ["Activate and protect agents using agent-initiated activation and communication" on page 1460](#) for details.
2. In the upper right corner of the Deep Security Manager console, click **Support > Deployment Scripts**.
3. Select the platform on which you are deploying the software.
4. Select **Activate agent automatically after installation**.

Agents must be activated before you apply a policy to protect the computer. Activation registers the agent with the manager during an initial communication.

5. Optionally, select the **Security Policy, Computer Group, Relay Group, Proxy to contact Deep Security Manager, and Proxy to contact Relay(s)**.
6. Optionally (but highly recommended), select **Validate Deep Security Manager TLS certificate**.

When this option is selected, it checks that Deep Security Manager is using a valid TLS certificate from a trusted certificate authority (CA) when downloading the agent software,

which can help prevent a "man in the middle" attack. You can check whether Deep Security Manager is using a valid CA certificate by looking at the browser bar in the Deep Security Manager console. By default, Deep Security Manager uses a self-signed certificate, which is not compatible with the **Validate Deep Security Manager TLS certificate** option. If your Deep Security Manager is not behind a load balancer, see ["Replace the Deep Security Manager TLS certificate" on page 1570](#) for instructions on replacing the default self-signed certificate with a certificate from a trusted certificate authority. If the manager is behind a load balancer, you will need to replace the load balancer's certificates.

7. Optionally (but highly recommended), select **Validate the signature on the agent installer** to have the deployment script initiate a digital signature check on the agent installer file. If the check is successful, the agent installation proceeds. If the check fails, the agent installation is aborted. Before you enable this option, understand that:
 - This option is only supported for Linux and Windows installers (RPM, DEB, or MSI files).
 - (Linux only) This option requires that you import the public signing key to each agent computer where the deployment script will run. For details, see ["Check the signature on an RPM file" on page 430](#) and ["Check the signature on a DEB file" on page 432](#).
8. The deployment script generator displays the script. Click **Copy to Clipboard** and paste the deployment script in your preferred deployment tool, or click **Save to File**.

Deployment Scripts

For platforms other than Windows and Linux, please see the installation guide.

Platform: Linux Agent Deployment

Activate Agent automatically after installation. (Required if you want to assign a security policy)

Security Policy: None

Computer Group: Computers

Relay Group: Primary Tenant Relay Group

Proxy to contact Deep Security Manager: Select a proxy...

Proxy to contact Relay(s): Select a proxy...

NOTE Hostname, description, unique identifiers and other properties can also be set on agent-initiated activation. See the [Command-Line Instructions](#) page in the online help for more information.

Validate Deep Security Manager TLS certificate. [Learn More](#)

Validate the digital signature on the agent installer. [Learn More](#)

```
#!/bin/bash
ACTIVATIONURL='dsm://agents.deepsecurity.trendmicro.com:443/'
MANAGERURL='https://app.deepsecurity.trendmicro.com:443'
```

Save to File... Copy to Clipboard Close

Note: The deployment scripts generated by Deep Security Manager for Windows agent deployments require Windows PowerShell version 4.0 or later. You must run PowerShell as

an Administrator and you may have to run the following command to be able to run scripts:

```
Set-ExecutionPolicy RemoteSigned
```

Note: If you want to deploy an agent to an early version of Windows or Linux that doesn't include PowerShell 4.0 or curl 7.34.0 at a minimum, make sure that early TLS is allowed on the manager and relays. See "[Determine whether TLS 1.2 is enforced](#)" on page 1837 and "[Enable early TLS \(1.0\)](#)" on page 1835 for details. Also edit the deployment script as follows:

- **Linux:** Remove the `--tls1.2` tag.
- **Windows:** Remove the `#requires -version 4.0` line. Also remove the `[Net.ServicePointManager]::SecurityProtocol = [Net.SecurityProtocolType]::Tls12;` line so that early TLS (version 1.0) is used to communicate with the manager.

If you are using Amazon Web Services and deploying new Amazon EC2, Amazon WorkSpace, or VPC instances, copy the generated script and paste it into the **User Data** field. This will let you launch existing Amazon Machine Images (AMIs) and automatically install and activate the agent at startup. The new instances must be able to access the URLs specified in the generated deployment script. This means that your Deep Security Manager must be either Internet-facing, connected to AWS via VPN or Direct Link, or that your Deep Security Manager be deployed on Amazon Web Services too.

When copying the deployment script into the **User Data** field for a **Linux** deployment, copy the deployment script as-is into the "User Data" field and CloudInit will execute the script with `sudo`. (If there are failures, they will be noted in `/var/log/cloud-init.log`.)

Note: The **User Data** field is also used with other services like CloudFormation. For more information, see:

<https://docs.aws.amazon.com/AWSCloudFormation/latest/UserGuide/aws-properties-waitcondition.html>

Troubleshooting and tips

- If you are attempting to run a deployment script and see exit code 2 "TLS certificate validation for the agent package download has failed. Please check that your Deep Security Manager TLS certificate is signed by a trusted root certificate authority. For more information, search for "deployment scripts" in the Deep Security Help Center.", the deployment script was created with the **Validate Deep Security Manager TLS**

certificate check box selected. This error appears if Deep Security Manager is using a certificate that is not publicly trusted (such as the default self-signed certificate) for the connection between Deep Security Manager and its agents, or if there is a problem with a third-party certificate, such as a missing certificate in the trust chain between your certificate and the trusted CA. For information on certificates, see ["Replace the Deep Security Manager TLS certificate" on page 1570](#). As an alternative to replacing the trusted certificate, you can clear the **Validate Deep Security Manager TLS certificate** check box when generating a deployment script. Note that this is not recommended for security reasons.

- If you are attempting to deploy the agent from PowerShell (x86), you will receive the following error: `C:\Program Files (x86)\Trend Micro\Deep Security Agent\dsa_control'` is not recognized as the name of a cmdlet, function, script file, or operable program. Check the spelling of the name, or if a path was included, verify that the path is correct and try again.

The PowerShell script expects the environment variable for `ProgramFiles` to be set to "Program Files", not "Program Files (x86)". To resolve the issue, close PowerShell (x86) and run the script in PowerShell as an administrator.

- On Windows computers, the deployment script will use the same proxy settings as the local operating system. If the local operating system is configured to use a proxy and the Deep Security Manager is accessible only through a direct connection, the deployment script will fail.
- The deployment script can be modified to perform agent updates instead of new installs by changing the `rpm -ihv` to `rpm -U`.
- If there is a need to control the specific agent version used by the deployment scripts there are 2 options to meet this goal:
 - Use agent version control. See ["Configure agent version control" on page 1442](#) for details. This approach has the advantage that you do not have to hard-code the agent version itself into each script which can be a more flexible approach for some deployments.
 - Either modify the deployment script, or write your own scripts, to meet requirements specific to your deployment. Details on the URL format to download agents can be found here ["URL format for download of the agent" on the next page](#).
- Instead of using the deployment scripts generated by the manager, you can use your own automation method coupled with an agent download URL to automate the download and

installation of the agent. For details, see ["URL format for download of the agent"](#) on the [next page](#).

URL format for download of the agent

The Deep Security Agent software package can be downloaded from Deep Security Manager, using a well-defined URL format.

In most cases, use of the [standard deployment scripts](#) (which, by the way, also use this same URL format described in this section to download the agent software) is the quickest way to get started and will meet the majority of your deployment requirements.

Use of this URL format directly is useful if you require further customization for the download and install of agents. For example, in some cases it may be necessary to have the deployment scripts that run on each server point to a local storage location (for example, AWS S3) rather than have each server reach out to the manager to download software. You can use this URL format to build your own automation to periodically download new agent versions to your local storage location, and then point the agent deployment scripts that run on each server to your local storage location to meet this objective.

Topics:

- ["Agent download URL format" below](#)
- ["<dsm fqdn> parameter" on the next page](#)
- ["<filename> parameter" on the next page](#)
- ["<agent version> parameter" on page 1796](#)
 - ["Should I include the <agent version> explicitly in my scripts?" on page 1796](#)
- ["<platform>, <arch>, and <filename> parameters" on page 1797](#)
 - ["Examples" on page 1800](#)
- ["Exceptions for backwards compatibility" on page 1800](#)
- ["Using agent version control to define which agent version is returned" on page 1801](#)
 - ["Examples" on page 1801](#)
 - ["Interactions between the <agent version> parameter and agent version control" on page 1802](#)

Agent download URL format

The URL format used to download the agent is:

```
https://<dsm fqdn>/software/agent/<platform>/<arch>/<agent
version>/<filename>
```

All the parameters that comprise the URL format are described below.

<dsm fqdn> parameter

The <dsm fqdn> parameter is the fully-qualified domain name of the manager, including the [listening port number](#).

Example:

```
example.com:4119
```

<filename> parameter

The <filename> parameter is the file name of the agent installer file. The file name is dependent on the installation process used by each platform:

Platform	<filename>
Linux Red Hat Enterprise Linux, CentOS, Oracle, CloudLinux, Amazon Linux, SUSE	agent.rpm
Linux Debian, Ubuntu	agent.deb
Windows	agent.msi
AIX	agent.bff.gz
Solaris 11+	agent.p5p.gz
Solaris 10 or earlier	agent.pkg.gz

Note: The manager does not validate the file name itself; however when a file name is specified, the extension must be one of `.rpm`, `.msi`, `.deb`, `.gz`. If any other file name is specified, the file name returned by the manager will always be one of the names provided in the table above.

<agent version> parameter

The `<agent version>` parameter is optional.

When this parameter is not specified, the latest agent in the manager's local inventory for the target platform is returned.

When this parameter is specified, this represents the agent version string. For example "12.0.0.123".

Should I include the <agent version> explicitly in my scripts?

If your intent is to only use a specific version of the agent in a controlled environment, then explicitly adding the agent version to the URL will accomplish this goal.

When deploying agents at scale, it should be noted that adding the agent version in the URL (which hardcodes this agent version into every script you distribute) can create challenges for security operations teams that will be distributing scripts to many applications teams.

Consider the process that will be needed when the time arrives to use a newer version of the agent. If the `<agent version>` is hardcoded in each script you distribute, this will require that each of these scripts requires an update to start using the new agent version. If you have many internal application teams, the process to request changes to each one of these scripts in use can be significant.

Deep Security provides two options to deal with this challenge:

- Simply use scripts that omit the `<agent version>` component from the path.

If using the latest agent in the manager's local inventory meets your requirements, this is the most straightforward option to use.

- Use agent version control

Agent version control provides the ability for the Deep Security administrator to select on a per-platform basis exactly what agent version is returned from the manager. More detail on

agent version control and how to leverage this feature from your scripts can be found at ["Using agent version control to define which agent version is returned" on page 1801](#).

<platform>, <arch>, and <filename> parameters

The <platform>, <arch>, and <filename> parameters should be replaced with the strings listed in the table below.

Note: <platform> and <arch> are case-sensitive.

Platform	Distribution	<platform>	<arch>	<filename>	Example
Linux	Amazon 1	amzn1	x86_64	agent.rpm	/software/agent/amzn1/x86_64/agent.rpm
	Amazon 2	amzn2	x86_64	agent.rpm	/software/agent/amzn2/x86_64/agent.rpm
	CloudLinux 6	CloudLinux_6	x86_64	agent.rpm	/software/agent/CloudLinux_6/x86_64/agent.rpm
	CloudLinux 7	CloudLinux_7	x86_64	agent.rpm	/software/agent/CloudLinux_7/x86_64/agent.rpm
	CloudLinux 8	CloudLinux_8	x86_64	agent.rpm	/software/agent/CloudLinux_8/x86_64/agent.rpm
	Debian 7	Debian_7	x86_64	agent.deb	/software/agent/Debian_7/x86_64/agent.deb
	Debian 8	Debian_8	x86_64	agent.deb	/software/agent/Debian_8/x86_64/agent.deb
	Debian 9	Debian_9	x86_64	agent.deb	/software/agent/Debian_9/x86_64/agent.deb
	Oracle Linux 6	Oracle_OL6	x86_64	agent.rpm	/software/agent/Oracle_OL6/x86_64/agent.rpm
	Oracle Linux 6	Oracle_OL6	i386	agent.rpm	/software/agent/Oracle_OL6/i386/agent.rpm

Platform	Distribution	<platform>	<arch>	<filename>	Example
	Oracle Linux 7	Oracle_OL7	x86_64	agent.rpm	/software/agent/Oracle_OL7/x86_64/agent.rpm
	RedHat 6	RedHat_EL6	x86_64	agent.rpm	/software/agent/RedHat_EL6/x86_64/agent.rpm
	RedHat 6	RedHat_EL6	i386	agent.rpm	/software/agent/RedHat_EL6/i386/agent.rpm
	RedHat 7	RedHat_EL7	x86_64	agent.rpm	/software/agent/RedHat_EL7/x86_64/agent.rpm
	RedHat 8	RedHat_EL8	x86_64	agent.rpm	/software/agent/RedHat_EL8/x86_64/agent.rpm
	SuSE 11	SuSE_11	x86_64	agent.rpm	/software/agent/SuSE_11/x86_64/agent.rpm
	SuSE 11	SuSE_11	i386	agent.rpm	/software/agent/SuSE_11/i386/agent.rpm
	SuSE 12	SuSE_12	x86_64	agent.rpm	/software/agent/SuSE_12/x86_64/agent.rpm
	SuSE 15	SuSE_15	x86_64	agent.rpm	/software/agent/SuSE_15/x86_64/agent.rpm
	Ubuntu 16.04	Ubuntu_16.04	x86_64	agent.deb	/software/agent/Ubuntu_16.04/x86_64/agent.deb
	Ubuntu 18.04	Ubuntu_18.04	x86_64	agent.deb	/software/agent/Ubuntu_18.04/x86_64/agent.deb
Windows		Windows	x86_64	agent.msi	/software/agent/Windows/x86_64/agent.msi
		Windows	i386	agent.msi	/software/agent/Windows/i386/agent.msi
Unix	Solaris 10 Updates	Solaris_5.10_U5	x86_64	agent.pkg.gz	/software/agent/Solaris_5.10_U5/x86_64/agent.pkg.gz

Platform	Distribution	<platform>	<arch>	<filename>	Example
	4-6				
		Solaris_5.10_U5	sparc	agent.pkg.gz	/software/agent/Solaris_5.10_U5/sparc/agent.pkg.gz
	Solaris 10 Updates 7-11	Solaris_5.10_U7	x86_64	agent.pkg.gz	/software/agent/Solaris_5.10_U7/x86_64/agent.pkg.gz
		Solaris_5.10_U7	sparc	agent.pkg.gz	/software/agent/Solaris_5.10_U7/sparc/agent.pkg.gz
	Solaris 11 Updates 1-3	Solaris_5.11	x86_64	agent.p5p.gz	/software/agent/Solaris_5.11/x86_64/agent.p5p.gz
		Solaris_5.11	sparc	agent.p5p.gz	/software/agent/Solaris_5.11/sparc/agent.p5p.gz
	Solaris 11 Update 4	Solaris_5.11_U4	x86_64	agent.p5p.gz	/software/agent/Solaris_5.11_U4/x86_64/agent.p5p.gz
		Solaris_5.11_U4	sparc	agent.p5p.gz	/software/agent/Solaris_5.11_U4/sparc/agent.p5p.gz
	AIX 5.3 (Deep Security Agent 9.0)	AIX_5.3	powerpc	agent.bff.gz	/software/agent/AIX_5.3/powerpc/agent.bff.gz
	AIX 6.1 (Deep Security Agent 9.0)	AIX_6.1	powerpc	agent.bff.gz	/software/agent/AIX_6.1/powerpc/agent.bff.gz
	AIX 7.1,	AIX_7.1	powerpc	agent.bff.gz	/software/agent/AIX_7.1/powerpc/agent.bff.gz

Platform	Distribution	<platform>	<arch>	<filename>	Example
	7.2 (Deep Security Agent 9.0)				
	AIX 6.1, 7.1, 7.2 (Deep Security Agent 12 and up)	AIX	powerpc	agent.bff.gz	/software/agent/AIX/powerpc/agent.bff.gz

Examples

Without <agent version>:

- `https://example.com:4119/software/agent/RedHat_EL7/x86_64/agent.rpm`
- `https://example.com:4119/software/agent/Windows/x86_64/agent.msi`

With <agent version>:

- `https://example.com:4119/software/agent/RedHat_EL7/x86_64/12.0.0.481/agent.rpm`
- `https://example.com:4119/software/agent/Windows/x86_64/12.0.0.481/agent.msi`

Exceptions for backwards compatibility

If no <filename> is provided after `[...]/<platform>/<arch>/`, the manager will return the agent download for that platform as described in the previous table.

If the path ends at `[...]<platform>/<arch>` (because both <agent version> and <filename> were not specified), the manager will return the agent download for that platform as described in the table above.

Examples:

- `https://example.com:4119/software/agent/RedHat_EL7/x86_64/`
- `https://example.com:4119/software/agent/Windows/x86_64`

Using agent version control to define which agent version is returned

The [agent version control](#) feature provides the ability to control what agents are returned when any URL request is made to Deep Security to download the agent.

To enable agent version control, send the following HTTP header with your URL request:

```
Agent-Version-Control: on
```

It should be noted that there are specific query parameters that are also required on each platform to use agent version control. They are:

Platform	Required query parameters	Example
Windows	tenantID, windowsVersion, windowsProductType	<code>/software/agent/Windows/x86_64/agent.msi?tenantID=123&windowsVersion=10.0.17134&windowsProductType=3</code>
Linux	tenantID	<code>/software/agent/RedHat_EL7/x86_64/agent.rpm?tenantID=123</code>
Solaris	tenantID	<code>/software/agent/Solaris_5.11_U4/x86_64/agent.p5p.gz?tenantID=123</code>
AIX	tenantID, aixVersion, aixRelease	<code>/software/agent/AIX/powerpc/agent.bff.gz?tenantID=123&aixVersion=7&aixRelease=1</code>

Note: The parameters in the table above are automatically generated by the deployment scripts.

Examples

For examples, refer to the sample deployment script generated from the manager. By default the deployment scripts generated by the manager use agent version control and demonstrate how to acquire these parameters for each platform.

Interactions between the <agent version> parameter and agent version control

Given the intent of the agent version control feature is to provide the Deep Security administrator control over which agent version is returned, there is a natural conflict with a URL request that also includes the <agent version> parameter.

For this reason you should not specify the <agent version> as part of your request when sending the `Agent-Version-Control: on` HTTP header.

If we see both the `Agent-Version-Control: on` HTTP header and the <agent version> parameter in the request, the version of the agent returned will be determined by the value taken from the agent version control configuration. (We will ignore the <agent version> in the URL.)

Automatically assign policies using cloud provider tags/labels

AWS tags, Azure tags, and GCP labels allow you to categorize your resources by assigning metadata to [AWS EC2 instances](#), [Azure VMs](#), or [GCP VM instances](#) in the form of keys and values. You can also [tag Amazon WorkSpaces](#) with the similar key and value pair. Deep Security can use this metadata to trigger the automatic assigning of a policy to a Deep Security Agent when that agent is activated. This is done by creating an event-based task in Deep Security and defining the event, policy, and metadata. Event-based tasks are used to monitor protected resources for specific events and then perform tasks based on certain conditions: in this case the event is agent-initiated activation and a specific AWS instance tag is the condition.

This article describes how to do this using the following examples:

- Policy: AIA_Policy
- AWS tag key: Group
- AWS tag value: development

Note: The example below is based on the assumption that the policy AIA_Policy has already been created.

1. Go to **Administration** -> **Event-Based Tasks** in the Deep Security Manager console and click **New**.

2. Select **Agent-Initiated Activation** from the **Event** list and click **Next**.
3. Select the **Assign Policy** check box, select **AIA_Policy** from the list, and click **Next**.
4. Select **Cloud Instance Metadata** from the list, type **Group** in the key field, and **development** into the value field.

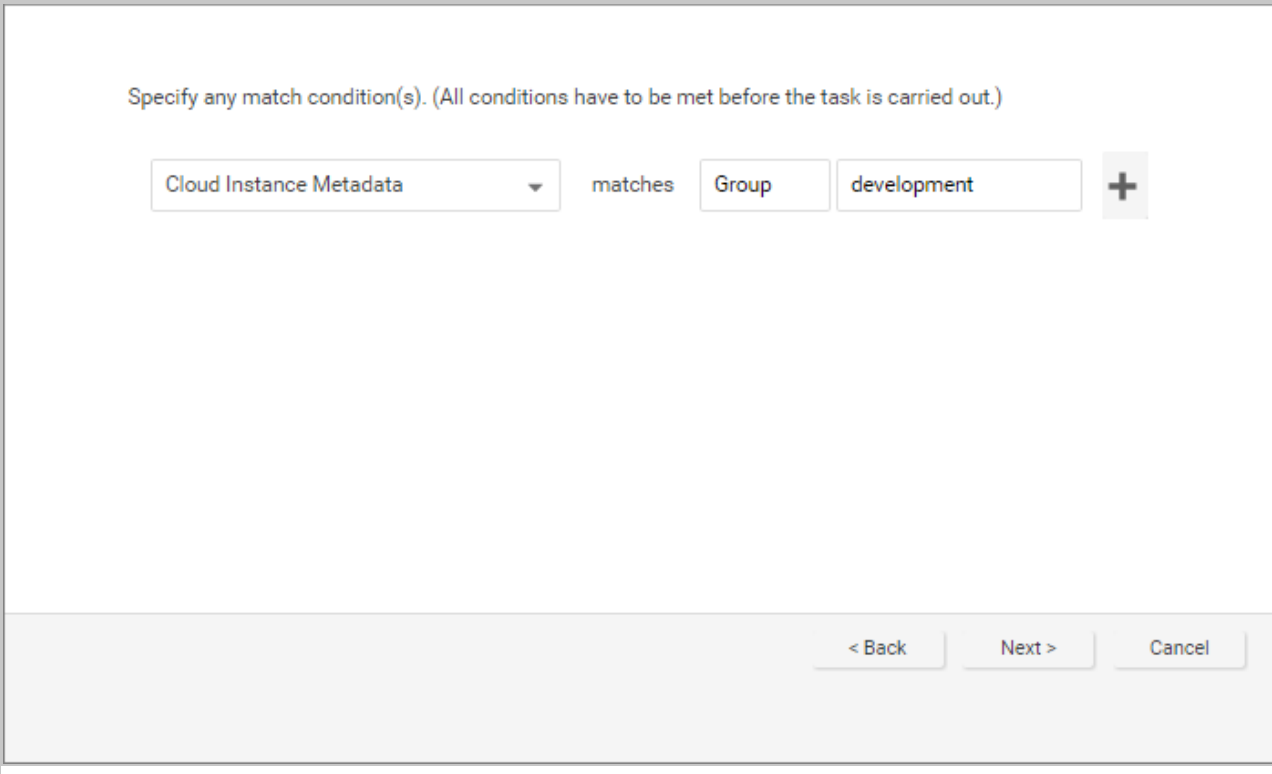

Specify any match condition(s). (All conditions have to be met before the task is carried out.)

Cloud Instance Metadata matches Group development +

< Back Next > Cancel

The screenshot shows a configuration window with a title bar. Below the title bar, there is a text prompt: "Specify any match condition(s). (All conditions have to be met before the task is carried out.)". Below this prompt, there is a form with three main components: a dropdown menu containing "Cloud Instance Metadata", the word "matches", a text input field containing "Group", and another text input field containing "development". To the right of the "development" field is a plus sign icon. At the bottom of the window, there is a grey bar containing three buttons: "< Back", "Next >", and "Cancel".

5. (Optional) To restrict the scope to only one cloud vendor, select **Cloud Vendor** from the list and select **AWS**, **Azure**, or **GCP** as the matching criteria. If you want to apply the rule to all three, don't define the Cloud Vendor condition.
6. Click **Next**.
7. Type and name for the event-based task and click **Finish** to save it.

You have now created an event-based task that will apply the AIA_Policy to an instance tagged with the key "Group" and the value "development" when the agent is activated on that instance.

Trust and compliance

About compliance

Trend Micro helps to accelerate compliance by consolidating multiple security controls into one product, while also delivering comprehensive auditing and reporting. For more information, see [Regulatory Compliance](#) on the Trend Micro website.

Depending on your requirements, see:

- ["Meet PCI DSS requirements with Deep Security" on page 1806](#)
- ["Common Criteria configuration" on page 1806](#)
- ["GDPR" on page 1810](#)
- ["FIPS 140 support" on page 1811](#)
- [Set up AWS Config Rules](#)
- ["Bypass vulnerability management scan traffic in Deep Security" on page 1823](#)
- ["Use TLS 1.2 with Deep Security" on page 1825](#)
- ["Enable TLS 1.2 strong cipher suites" on page 1839](#)

Agent package integrity check

Deep Security verifies your signature on the Deep Security Agent to ensure that the software files have not changed since the time of signing. An integrity check occurs when:

1. You're upgrading the Deep Security Agent.
2. You're enabling a new security module so the kernel support is being updated.

If the validation fails, plugin installations and agent upgrades are blocked.

Troubleshoot

ID	Event	Reason	Solution
5302	Agent/Plugin package signature	The signature files used to check the integrity of the agent are not available in your update source. Your	1. On the Alerts page, check for the "Relay Upgrade Required For Agent Integrity Check" alert. If the alert exists, see

ID	Event	Reason	Solution
	download failed.	Deep Security Relay might not be upgraded to the required version.	<p>"Supported Deep Security Relay versions" below and "Upgrade Deep Security Relay" on page 1624 accordingly. Confirm signature files sync to your update source.</p> <ol style="list-style-type: none"> 2. Confirm your signature files have synced to your update source. 3. Attempt to upgrade your agent or send your updated policy again. 4. If the issue isn't resolved, "Create a diagnostic package and logs" on page 1951 and send it to the Trend Micro support team.
5300	Agent/Plugin package signature validation failed.	The agent package might have been tampered with or something is wrong on the package.	<ol style="list-style-type: none"> 1. Backup and delete the possibly tampered file from your update source. 2. Delete the corresponding agent package from Deep Security Manager. 3. Re-download the agent package from the Download Center and import it to Deep Security Manager. 4. Confirm the package has synced to your update source. 5. Attempt to upgrade your agent or send your updated policy again. 6. If the issue isn't resolved, "Create a diagnostic package and logs" on page 1951 and send it to the Trend Micro support team.
5301	Agent/Plugin package validation failed.		
5303	Agent/Plugin package signature mismatch with the one in our policy.		

Supported Deep Security Relay versions

The following Deep Security Relay versions are supported:

- Deep Security 20
- Deep Security FR 2020-04-16 (12.5.0.834)(Windows)
- Deep Security FR 2020-05-19 (12.5.0.936)(Linux)

- Deep Security 12.0 update 8 (12.0.0.967)
- Deep Security 11.0 update 23 (11.0.1617)

Meet PCI DSS requirements with Deep Security

The [Payment Card Industry Data Security Standard](#) (PCI DSS) is an information security standard that promotes the safety of cardholder data. Deep Security can be used to help secure PCI data in accordance with the PCI DSS.

Tip:

For PCI compliance, see also [PCI DSS compliance in AWS](#) and "Use TLS 1.2 with Deep Security" on page 1825 or "Enable TLS 1.2 strong cipher suites" on page 1839.

Common Criteria configuration

Deep Security 20 has been issued a Common Criteria certificate. [Common Criteria](#) is an international standard for computer security certification. This topic describes how to deploy Deep Security in a Common Criteria Evaluation Assurance Level 2+ certified configuration (CC EAL2+). Use it in conjunction with the *Deep Security 20 Security Target* documentation.

Direct links to the Deep Security 20 Certification Report and the Deep Security 20 Security Target can be found here:

[Deep Security 20 Certification Report.](#)

[Deep Security 20 Security Target.](#)

Note: As part of Common Criteria standards, it is expected that Deep Security administrators have a good understanding of their organization's security policies and procedures, are trained in how to use Deep Security, and are able to configure Deep Security in accordance with the guidance provided in this article and the rest of the Deep Security 20 documentation.

To deploy the CC EAL2+ certified configuration, follow the steps below. All steps are mandatory, unless otherwise noted.

- ["Step 1: Install Deep Security" on the next page](#)
- ["Step 2: Enable FIPS mode" on page 1808](#)

- ["Step 3: Harden Deep Security to prevent unauthorized access" on the next page](#)
- ["Step 4: Enforce a strong password policy" on page 1809](#)
- ["Step 5: Disable the legacy APIs" on page 1809](#)
- ["Step 6: Configure email notifications for alerts" on page 1809](#)
- ["Next steps \(operating in the certified configuration\)" on page 1809](#)

Step 1: Install Deep Security

Begin by installing and configuring the Deep Security software as you normally would following the instructions in other sections of this Help Center. To deploy in the Common Criteria certified configuration, download and install the evaluated software versions from the [Deep Security Download Center](#).

When installing, make sure that:

- the facility housing Deep Security Manager, its database, Deep Security Virtual Appliances, ESXi servers, vCenter, vShield Manager, and NSX Manager are all physically secure.
- the Deep Security Manager is not running on a machine with other major applications, and is hardened in accordance with your organization's best practices.
- the Deep Security Manager computer is located within an isolated network segment where inbound and outbound traffic is strictly controlled.
- only authorized users with the correct administrative permissions can access the manager computer.
- only authorized users can access the agent and relay computers, if those users have administrative permissions on those machines.
- the environment provides reliable and secure domain name server (DNS) service and Network Time Protocol (NTP) service.
- the VMware virtual infrastructure (ESXi servers, vCenter, vShield Manager, NSX Manager) is sufficiently strong and protected against theft.
- the Deep Security Virtual Appliance's management interfaces exist on a segregated, internal-only network (restricted access).
- the Deep Security Virtual Appliance provides [Anti-Malware](#) only. If you need other modules, such as Intrusion Prevention (IPS), use the Deep Security Agent and appliance in combined mode. See ["Choose agentless vs. combined mode protection" on page 548](#).

- the Domain Name Server (DNS) response time is reasonable. There is a known issue in Deep Security that allows some malware to go undetected if the DNS response time is very slow.

Note: Use of Shift JIS (Shift_JIS) character encoding for the Japanese language is not supported by the Common Criteria configuration.

The remaining steps in this topic describe the modifications you must make to your initial installation and configuration to arrive at a Common Criteria evaluated configuration.

Step 2: Enable FIPS mode

You must configure Deep Security to operate in FIPS 140 mode. See "[FIPS 140 support](#)" on [page 1811](#) for instructions. There are quite a few steps, restrictions, and requirements. For example, the Deep Security Scanner (integration with SAP Netweaver) is not supported. All FIPS steps, restrictions, and requirements apply.

In addition to the completing the tasks outlined on the "[FIPS 140 support](#)" on [page 1811](#) page, you must also:

- Limit TLS to version 1.2 on SQL Server. For details, see [KB3135244 - TLS 1.2 support for Microsoft SQL Server](#) from Microsoft.
- Enable FIPS mode for the operating system being protected. For instructions on enabling FIPS mode on Windows, see [FIPS 140 Validation](#) from Microsoft.

Step 3: Harden Deep Security to prevent unauthorized access

You must harden Deep Security components to reduce their surface of vulnerability and prevent unauthorized access. Follow the links below to harden your system. You might have already completed some of these tasks when you set up FIPS mode.

Mandatory hardening tasks:

- "[Encrypt communication between the Deep Security Manager and the database](#)" on [page 1582](#)
- Harden the Deep Security database—if you're using SQL Server, see [Securing SQL Server](#) from Microsoft
- "[Replace the Deep Security Manager TLS certificate](#)" on [page 1570](#)

- ["Protect Deep Security Manager with an agent" on page 1566](#)
- Review the [Deep Security release notes](#) to avoid security-related known issues

Optional hardening tasks:

- [Bind Deep Security Agent to a specific manager](#)
- ["Enable or disable agent self-protection on Windows" on page 1466](#) (optionally, enable it)

Step 4: Enforce a strong password policy

You must enforce a strong password policy. See ["Enforce user password rules" on page 1597](#) for details. The policy must have these characteristics, at a minimum:

- the **User password minimum length** must be no less than the default of eight
- the **Number of incorrect sign-in attempts allowed (before lock out)** must be no greater than the default of five

Step 5: Disable the legacy APIs

You must disable the SOAP and Status Monitoring APIs as follows:

1. In Deep Security Manager, click **Administration > System Settings > Advanced**.
2. In the **SOAP Web Service API** section, select **Disabled**.
3. In the **Status Monitoring API** section, select **Disabled**.
4. Click **Save**.

Step 6: Configure email notifications for alerts

You must configure an email address to which all notifications will be sent. See ["Set up email notification for alerts" on page 1265](#). By default, Deep Security Manager sends an email notification for every alert. Do not disable any of the default alert notifications.

Next steps (operating in the certified configuration)

To use Deep Security in the certified configuration, make sure you:

- create accounts for additional users

An administration account (by default named MasterAdmin) was created when you installed Deep Security Manager. Create new accounts for additional users so that the MasterAdmin account is only (rarely) used as a backup by the original administrator responsible for Deep Security installation. Use the other accounts for ongoing administration and configuration tasks.

- stop using [Deep Security Manager's command line interface](#) (dsm_c)

This interface is permitted for the initial installation and configuration of the manager, but should not be used thereafter because it is not included in the CC EAL2+ certified configuration.

- stop using the [Deep Security Agent's command line interfaces](#) (dsa_control and dsa_query)

These interfaces are permitted during the initial installation and configuration of the agent, but should not be used thereafter because they are not included in the CC EAL2+ certified configuration.

- never shut down the Deep Security Virtual Appliance during normal operations.

If the appliance appears to be offline for an unknown reason, always investigate the cause.

GDPR

The European Union's (EU) General Data Protection Regulation (GDPR) mandates that organizations anywhere in the world processing EU citizen data reassess their data processing controls and put a plan in place to better protect it. For information about GDPR and Trend Micro, see the [Trend Micro GDPR Compliance](#) site.

For information about personal data collection in Deep Security, see "[Privacy and personal data collection disclosure](#)" on page 1844.

FIPS 140 support

Federal Information Processing Standard (FIPS) is a set of standards for cryptographic modules. For in-depth information about FIPS, see the [National Institute of Standards and Technology \(NIST\) website](#). Deep Security provides settings that enable cryptographic modules to run in a mode that is compliant with FIPS 140 standards. We have obtained certification for our [Java crypto module](#) and [Native crypto module \(OpenSSL\)](#).

Note: Deep Security currently supports FIPS 140-2 standards. As new versions of FIPS-140 are released, we will obtain certification to support those standards.

There are some differences between a Deep Security deployment running in FIPS mode instead of non-FIPS mode (see ["Differences when operating Deep Security in FIPS mode" on the next page](#)).

Tip: If you intend to replace the Deep Security Manager SSL certificate, do so before enabling FIPS mode. If you need to replace the certificate after enabling FIPS mode, you will need to disable FIPS mode, follow the instructions in ["Replace the Deep Security Manager TLS certificate" on page 1570](#), and then re-enable FIPS mode.

To operate Deep Security in a FIPS 140 mode, do the following:

1. Review ["Differences when operating Deep Security in FIPS mode" on the next page](#) to make sure the Deep Security features you require are available when operating in FIPS 140 mode.
2. Ensure that your Deep Security Manager and Deep Security Agents meet the ["System requirements for FIPS mode" on page 1813](#).
3. ["Enable FIPS mode for your Deep Security Manager" on page 1814](#).
4. If your Deep Security Manager needs to connect to an external service (such as an Active Directory, vCenter, or NSX Manager) using SSL, see ["Connect to external services when in FIPS mode" on page 1815](#).
5. ["Enable FIPS mode for the operating system of the computers you are protecting" on page 1815](#).
6. ["Enable FIPS mode for the Deep Security Agent on the computers you are protecting" on page 1816](#)
7. ["Enable FIPS mode for the Deep Security Virtual Appliance" on page 1817](#).

8. With some versions of the Linux kernel, such as, for example, Red Hat Enterprise Linux (RHEL) 7.0 GA, you must enable Secure Boot to enable FIPS mode. See "[Configure Linux Secure Boot for agents](#)" on page 504 for instructions.

You can also "[Disable FIPS mode](#)" on page 1822.

Differences when operating Deep Security in FIPS mode

Features available in FIPS mode

The following Deep Security features are not available when operating in FIPS mode:

- Connecting to virtual machines hosted on VMware vCloud, as described in "[Add virtual machines hosted on VMware vCloud](#)" on page 687. The **Administration > System Settings > Agents > Agentless vCloud Protection** settings are also unavailable.
- Multi-tenant environment.
- Deep Security Scanner (integration with SAP Netweaver).
- Threat Intelligence.
- Identity provider support via SAML 2.0

The following Deep Security features are available as of Deep Security Manager 20 LTS Update 2022-03-22:

- Load balancer settings are accessible via **Administration > System Settings > Advanced > Load Balancers**.
- The STARTTLS option, as part of SMTP settings.

How to check if FIPS mode is enabled

To see if FIPS mode is enabled on the Deep Security Manager, go to **Administration > System Information**. Under **System Details**, expand a **Manager Node**. The **FIPS** field indicates if FIPS mode is enabled or disabled.

Note: When FIPS is enabled for Deep Security Manager [deployed on multiple nodes](#), all Manager Nodes should show FIPS enabled.

System requirements for FIPS mode

Deep Security Manager requirements

The Deep Security Manager requirements with FIPS mode enabled are identical to those described in ["System requirements" on page 329](#), with a number of exceptions.

Only the following operating systems are supported:

- Red Hat Enterprise Linux 9 (64-bit)
- Red Hat Enterprise Linux 8 (64-bit)
- Red Hat Enterprise Linux 7 (64-bit)
- Windows Server 2019 (64-bit)
- Windows Server 2016 (64-bit)
- Windows Server 2012 or 2012 R2 (64-bit)
- Debian Linux 10 (64-bit)
- Debian Linux 11 (64-bit)

Only the following databases are supported:

- PostgreSQL 13 (see ["Using FIPS mode with a PostgreSQL database" on page 1817](#))
- PostgreSQL 12 (see ["Using FIPS mode with a PostgreSQL database" on page 1817](#))
- PostgreSQL 11 (see ["Using FIPS mode with a PostgreSQL database" on page 1817](#))
- PostgreSQL 9.6 (see ["Using FIPS mode with a PostgreSQL database" on page 1817](#))
- Microsoft SQL Server 2019 Enterprise Edition (see ["Using FIPS mode with a Microsoft SQL Server database" on page 1821](#))
- Microsoft SQL Server 2016 Enterprise Edition (see ["Using FIPS mode with a Microsoft SQL Server database" on page 1821](#))
- Microsoft SQL Server 2014 Enterprise Edition (see ["Using FIPS mode with a Microsoft SQL Server database" on page 1821](#))
- Microsoft SQL Server 2012 Enterprise Edition (see ["Using FIPS mode with a Microsoft SQL Server database" on page 1821](#))

Note: Oracle Database is not supported, even if it has enabled FIPS mode for SSL connections.

Note: Microsoft SQL Server named pipes are not supported.

Note: AWS Marketplace does not support FIPS mode.

Deep Security Agent requirements

The Deep Security Agent requirements with FIPS mode enabled are identical to those described in "[System requirements](#)" on [page 329](#). FIPS mode is not supported with all operating systems. To check which operating systems are supported, see "[Supported features by platform](#)" on [page 360](#).

Deep Security Virtual Appliance requirements

To support FIPS mode on the appliance, you need the following:

- Deep Security Manager 11.0 Update 3 or later.
- Deep Security Virtual Appliance 10.0, or 11.0 or later.
- Deep Security Agent 11.0 for RHEL 7 or later (to be used as the appliance's embedded agent).

For details on the appliance's system requirements, see "[System requirements](#)" on [page 329](#).

Enable FIPS mode for your Deep Security Manager

Enable FIPS mode for a Deep Security Manager on Windows

1. Use the Services window of the Microsoft Management Console to stop the Trend Micro Deep Security Manager service.
2. In the Windows command line, go to the Deep Security Manager's working folder, for example, `C:\Program Files\Trend Micro\Deep Security Manager`.
3. Enter the following command to enable FIPS mode:

```
dsm_c -action enablefipsmode
```

4. Restart the Deep Security Manager service.

Enable FIPS mode for a Deep Security Manager on Linux

1. On the Deep Security Manager computer, open a command line and go to the Deep Security Manager's working folder, for example, `/opt/dsm`.
2. Enter the following command to stop the Deep Security Manager service:

```
service dsm_s stop
```

3. Enter the following command to enable FIPS mode:

```
dsm_c -action enablefipsmode
```

4. Enter the following command to restart the Deep Security Manager service:

```
service dsm_s start
```

Connect to external services when in FIPS mode

When Deep Security Manager is operating in FIPS mode and you want to connect to an external service (such as an Active Directory, vCenter, or NSX Manager) with an SSL connection, you must import the SSL certificate for that external service into the manager before connecting to it. For instructions on how to import the certificate, see ["Manage trusted certificates" on page 1603](#).

For instructions on importing computers from an Active Directory, see ["Add Active Directory computers" on page 636](#).

For instructions on synchronizing user information with an Active Directory, see ["Add and manage users" on page 1483](#).

For instructions on adding a VMware vCenter to Deep Security Manager, see ["Add a vCenter - FIPS mode" on page 686](#).

Enable FIPS mode for the operating system of the computers you are protecting

For instructions on enabling FIPS mode for supported operating systems, refer to the following documents from the operating system providers:

- **Windows:** [System cryptography: Use FIPS compliant algorithms for encryption, hashing, and signing](#) security setting effects in Windows XP and in later versions of Windows

- [RHEL 7 or CentOS 7: Federal Standards and Regulations and How can I make RHEL 6 or RHEL 7 FIPS 140-2 compliant](#)
- [RHEL 8: RHEL 8 is designed for FIPS 140-2 requirements](#)
- [RHEL 9: Installing the system in FIPS mode](#)
- [Amazon Linux 2: Enabling FIPS mode in Amazon Linux 2](#)
- [SUSE Linux Enterprise Server 12: Enabling FIPS mode in SUSE Linux Enterprise Server 12](#)
- [SUSE Linux Enterprise Server 15: Enabling FIPS mode in SUSE Linux Enterprise Server 15](#)
- [Oracle Linux 8: Installing FIPS Validated Cryptographic Modules for Oracle Linux 8](#)
- [Rocky Linux 9: Installing the system in FIPS mode](#) using the RHEL 9 documentation
- [Miracle Linux 8: Installing the system in FIPS mode](#) using the RHEL 8 documentation
- [Miracle Linux 9: Installing the system in FIPS mode](#) using the RHEL 9 documentation
- [Debian Linux 10: Enabling FIPS mode in Debian](#)
- [Debian Linux 11: Enabling FIPS mode in Debian](#)

Enable FIPS mode for the Deep Security Agent on the computers you are protecting

Note: The following information is not applicable to new Deep Security 11.0 or later agents that you install after enabling FIPS mode in Deep Security Manager. In these versions, FIPS mode is already enabled for the agent.

Enable FIPS mode for a Windows agent

1. In the Windows system root folder (for example, `C:\Windows`), look for a file named `ds_agent.ini`. Open the existing file in a text editor or create a new file.
2. Add the following line to the file:

```
FIPSMODE=1
```

3. Restart the Deep Security Agent service.

Enable FIPS mode for Linux agents

The following Linux agents are supported: RHEL 7, RHEL 8, RHEL 9, CentOS 7, Amazon Linux 2, Ubuntu 18, Ubuntu 20, SUSE 12, SUSE 15, Oracle 8, Rocky 9, Miracle 8, Miracle 9, Debian Linux 10, and Debian Linux 11.

1. In `/etc/`), look for a file named `ds_agent.conf`. Open the file in a text editor or create a new file if you don't have one already.
2. Add this line to the file:

```
FIPSMode=1
```

3. Restart the Deep Security Agent:

Using a SysV init script: `/etc/init.d/ds_agent restart`

Using a systemd command: `systemctl restart ds_agent`

Note: For more information about enabling FIPS mode on Ubuntu 18 or Ubuntu 20, see [FIPS for Ubuntu](#).

Enable FIPS mode for the Deep Security Virtual Appliance

1. In `<DSVA_root>/etc/`, look for a file named `ds_agent.conf`. Open the existing file in a text editor or create a new file.
2. Add the following line to the file:

```
FIPSMode=1
```

3. Restart the appliance from the command line:

Using a SysV init script: `/etc/init.d/ds_agent restart`

Using a systemd command: `systemctl restart ds_agent`

Using FIPS mode with a PostgreSQL database

If you are using PostgreSQL as your Deep Security Manager database, there is a number of requirements in addition to those outlined in "[Database requirements](#)" on page 434.

In FIPS mode, the keystore must be the BCFKS type. Instead of converting the Java default keystore (`C:\Program Files\Trend Micro\Deep Security Manager\jre\lib\security\cacerts` or `/opt/dsm/jre/lib/security/cacerts`) directly,

copy the default keystore to another location and use it as the default keystore for SSL connection:

1. Create the PostgreSQL environment.
2. Copy the `server.crt` file from the PostgreSQL server and paste them into `<Deep_Security_Manager_install_folder>`.
3. Install Deep Security Manager.
4. ["Enable FIPS mode for your Deep Security Manager" on page 1814.](#)
5. Copy the default Java cacerts file into the Deep Security Manager root installation folder:

On Windows:

```
copy "C:\Program Files\Trend Micro\Deep Security Manager\jre\lib\security\cacerts" "C:\Program Files\Trend Micro\Deep Security Manager\cacerts"
```

On Linux:

```
cp "/opt/dsm/jre/lib/security/cacerts" "/opt/dsm/cacerts"
```

6. Convert the keystore file from JKS to BCFKS. The following command creates a `cacerts.bcfks` file in the Deep Security Manager installation folder:

On Windows:

```
cd C:\Program Files\Trend Micro\Deep Security Manager\jre\bin  
  
keytool -importkeystore -srckeystore "C:\Program Files\Trend Micro\Deep Security Manager\cacerts" -srcstoretype JKS -deststoretype BCFKS -destkeystore "C:\Program Files\Trend Micro\Deep Security Manager\cacerts.bcfks" -srcstorepass <changeit> -deststorepass <changeit> -providerpath "C:\Program Files\Trend Micro\Deep Security Manager\jre\lib\ext\ccj-3.0.0.jar" -providerclass com.safelogic.cryptocomply.jcajce.provider.CryptoComplyFipsProvider
```

where `<changeit>` is replaced with your own values.

On Linux:

```
cd /opt/dsm/jre/bin  
  
keytool -importkeystore -srckeystore "/opt/dsm/cacerts" -srcstoretype JKS -deststoretype BCFKS -destkeystore "/opt/dsm/cacerts.bcfks" -srcstorepass <changeit> -deststorepass <changeit> -providerpath
```

```
"/opt/dsm/jre/lib/ext/ccj-3.0.0.jar" -providerclass  
com.safelogic.cryptocomply.jcajce.provider.CryptoComplyFipsProvider
```

where `<changeit>` is replaced with your own values.

7. Import the certificate ("Deep_Security_Manager_root_folder/server.crt"):

On Windows:

```
cd C:\Program Files\Trend Micro\Deep Security Manager\jre\bin  
  
keytool -import -alias psql -file "C:\Program Files\Trend Micro\Deep  
Security Manager\server.crt" -keystore "C:\Program Files\Trend  
Micro\Deep Security Manager\cacerts.bcfks" -storepass <changeit> -  
provider  
com.safelogic.cryptocomply.jcajce.provider.CryptoComplyFipsProvider -  
providerpath "C:\Program Files\Trend Micro\Deep Security  
Manager\jre\lib\ext\ccj-3.0.0.jar" -storetype BCFKS
```

where `<changeit>` is replaced with your own value.

On Linux:

```
cd /opt/dsm/jre/bin  
  
keytool -import -alias psql -file "/opt/dsm/server.crt" -keystore  
"/opt/dsm/cacerts.bcfks" -storepass <changeit> -provider  
com.safelogic.cryptocomply.jcajce.provider.CryptoComplyFipsProvider -  
providerpath "/opt/dsm/jre/lib/ext/ccj-3.0.0.jar" -storetype BCFKS
```

where `<changeit>` is replaced with your own value.

8. The Deep Security installer can use a `.vmoptions` file to assign the JVM parameter:

On Windows, create a file named `Deep Security Manager.vmoptions` in the installation folder and add the following text in the file:

Note: Ensure that the file extension is `.vmoptions`.

```
-Djavax.net.ssl.keyStoreProvider=CCJ
```

```
-Djavax.net.ssl.trustStore=C:\Program Files\Trend Micro\Deep Security  
Manager\cacerts.bcfks
```

```
-Djavax.net.ssl.trustStorePassword=<changeit>
```

```
-Djavax.net.ssl.keyStoreType=BCFKS
```

```
-Djavax.net.ssl.trustStoreType=BCFKS
```

where `<changeit>` is replaced with your own value.

On Linux, create a file named `dsm_s.vmoptions` in the installation folder and add the following text in the file:

```
-Djavax.net.ssl.keyStoreProvider=CCJ
```

```
-Djavax.net.ssl.trustStore=/opt/dsm/cacerts.bcfks
```

```
-Djavax.net.ssl.trustStorePassword=<changeit>
```

```
-Djavax.net.ssl.keyStoreType=BCFKS
```

```
-Djavax.net.ssl.trustStoreType=BCFKS
```

where `<changeit>` is replaced with your own value.

9. Open the `<Deep Security Manager directory>\webclient\webapps\ROOT\WEB-INF\dsm.properties` file in a text editor and add:

```
database.PostgreSQL.connectionParameters=ssl\=true
```

10. Open the `/opt/postgresql/data/postgresql.conf` file in a text editor and add:

```
ssl= on
```

```
ssl_cert_file= 'server.crt'
```

```
ssl_ksy_file= 'server.key'
```

11. Restart PostgreSQL and then restart the Deep Security Manager service.
12. Check the connection:

```
cd /opt/postgresql/bin
```

```
./psql -h 127.0.0.1 -Udsm dsm
```

Enter the password when prompted. You should see:

```
dsm=> select a.client_addr, a.application_name, a.username, s.* from  
pg_stat_ssl s join pg_stat_activity a using (pid) where  
a.datname='dsm';
```

Using FIPS mode with a Microsoft SQL Server database

If you are using Microsoft SQL Server as your Deep Security Manager database, you must set up the database SSL encryption using the following instructions before enabling FIPS mode:

1. Stop the Deep Security Manager service.
2. Create a BCFKS keystore file with the SQL server certificate. You can use the keytool in `C:\Program Files\Trend Micro\Deep Security Manager\jre\bin`.
3. Use the following command to import the SQL server certificate (`C:\sqlserver_cert.cer`) to a new keystore file (`C:\Program Files\Trend Micro\Deep Security Manager\mssql_keystore.bcfks`):

Note: If the Deep Security Manager package does not contain a `ccj-3.0.0.jar` file, get the JAR file from the FIPS page.

```
keytool -import -alias mssql -file "C:\sqlserver_cert.cer" -keystore
"C:\Program Files\Trend Micro\Deep Security Manager\mssql_
keystore.bcfks" -storepass <changeit> -provider
com.safelogic.cryptocomply.jcajce.provider.CryptoComplyFipsProvider -
providerpath "C:\Program Files\Trend Micro\Deep Security
Manager\jre\lib\ext\ccj-3.0.0.jar" -storetype BCFKS
```

where `<changeit>` is replaced with your own value.

During the import process, answer "YES" to trust this certificate.

4. If the keystore file is created successfully, you can use the following command to see the certificate listed in the keystore:

```
keytool -list -v -keystore "C:\Program Files\Trend Micro\Deep Security
Manager\mssql_keystore.bcfks" -provider
com.safelogic.cryptocomply.jcajce.provider.CryptoComplyFipsProvider -
providerpath "C:\Program Files\Trend Micro\Deep Security
Manager\jre\lib\ext\ccj-3.0.0.jar" -storetype BCFKS -storepass
<changeit>
```

where `<changeit>` is replaced with your own value.

5. Open the `C:\Program Files\Trend Micro\Deep Security Manager\webclient\webapps\ROOT\WEB-INF\dsm.properties` file in a text editor and add the following lines enable SSL/TLS and FIPS settings:

```
database.SqlServer.encrypt=true
```

```
database.SqlServer.trustServerCertificate=false
```

```
database.SqlServer.fips=true
```

```
database.SqlServer.trustStorePassword=<changeit>
```

```
database.SqlServer.fipsProvider=CCJ
```

```
database.SqlServer.trustStoreType=BCFKS
```

```
database.SqlServer.trustStore=C:\\Program Files\\Trend Micro\\Deep  
Security Manager\\mssql_keystore.bcfks
```

where `<changeit>` is replaced with your own value.

6. Optionally, you can change the SQL server and client connection protocols from Named Pipes to TCP/IP. This allows for FIPS support:
 - a. In the SQL Server Configuration Manager, go to **SQL Network Configuration > Protocols for MSSQLSERVER** and enable TCP/IP.
 - b. Go to **SQL Native Client 11.0 Configuration > Client Protocols** and enable TCP/IP.
 - c. Follow the instruction provided by Microsoft to enable encrypted connections for an instance of the SQL Server database. See [Enable Encrypted Connections to the Database Engine](#).
 - d. Edit the `dsm.properties` file to change `database.sqlserver.driver=MSJDBC` and `database.SqlServer.namedPipe=false`.
7. Restart the Deep Security Manager service.
8. ["Enable FIPS mode for your Deep Security Manager" on page 1814](#).

Disable FIPS mode

1. To disable FIPS mode for the Deep Security Manager, follow the instructions that you used to enable it (see ["Enable FIPS mode for your Deep Security Manager" on page 1814](#)), but use the following command instead of step 3:

```
dsm_c -action disablefipsmode
```

2. To disable FIPS mode for the Deep Security Agent, follow the instructions that you used to enable it (see ["Enable FIPS mode for the Deep Security Agent on the computers you are protecting" on page 1816](#)), but instead of `FIPSMODE=1`, use `FIPSMODE=0`.

Bypass vulnerability management scan traffic in Deep Security

If you are using a vulnerability management provider such as Qualys or Nessus (for PCI compliance, for example), you need to set up Deep Security to bypass or allow this provider's scan traffic through untouched.

- ["Create a new IP list from the vulnerability scan provider IP range or addresses" below](#)
- ["Create firewall rules for incoming and outbound scan traffic" below](#)
- ["Assign the new firewall rules to a policy to bypass vulnerability scans" on the next page](#)

After these firewall rules have been assigned to the new policy, the Deep Security Manager will ignore ANY traffic from the IPs you have added in your IP List.

Deep Security will not scan the vulnerability management provider traffic for stateful issues or vulnerabilities - it will be allowed through untouched.

Create a new IP list from the vulnerability scan provider IP range or addresses

Have handy the IP addresses that the vulnerability scan provider has given you.

1. In the Deep Security Manager, go to **Policies**.
2. In the left pane, expand **Lists > IP Lists**.
3. Click **New > New IP List**.
4. Type a **Name** for the new IP List, for example "Qualys IP list".
5. Paste the IP addresses that the vulnerability management provider has given you into the **IP(s)** box, one per line.
6. Click **OK**.

Create firewall rules for incoming and outbound scan traffic

After you've created the IP list, you need to create two firewall rules: one for incoming and one for outgoing traffic.

Name them as suggested, below:

```
<name of provider> Vulnerability Traffic - Incoming
```

```
<name of provider> Vulnerability Traffic - Outgoing
```

1. In the main menu, click **Policies**.
2. In the left pane, expand **Rules**.
3. Click **Firewall Rules > New > New Firewall Rule**.
4. Create the first rule to bypass Inbound AND Outbound for TCP and UDP connections that are incoming to and outgoing from vulnerability management provider.

Tip: For settings not specified, you can leave them as the default.

Name: (suggested) <name of provider> Vulnerability Traffic - Incoming

Action: Bypass

Protocol: Any

Packet Source: IP List and then select the new IP list created above.

5. Create a second rule:

Name: <name of provider> Vulnerability Traffic - Outgoing

Action: Bypass

Protocol: Any

Packet Destination: IP List and then select the new IP list created above.

Note: For firewall rules to work for a computer, the firewall **Configuration** must be set to "On" or "Inherited (On)" (**Computers > Firewall > General**). For firewall rules to work through a policy, the **Firewall State** must be set to "On" (**Policies > Firewall > General**).

Assign the new firewall rules to a policy to bypass vulnerability scans

Identify which policies are already used by computers that will be scanned by the vulnerability management provider.

Edit the policies individually to assign the rules in the firewall module.

1. Click **Policies** on the main menu.
2. Click **Policies** in the left pane.
3. In the right pane, for each policy, double-click to open the policy details.
4. In the pop-up, in the left pane, click **Firewall**.
5. Under **Assigned Firewall Rules**, click **Assign/Unassign**.
6. Ensure your view at the top-left shows **All** firewall rules in the .
7. Use the search window to find the rules you created and select them.
8. Click **OK**.

Use TLS 1.2 with Deep Security

In Deep Security Manager 11.1 and higher, TLS 1.2 is enforced by default for new installations.

Review the table below to determine whether you need to take action.

Note: If you want to enable TLS 1.2 with only strong, A+-rated, cipher suites, see instead ["Enable TLS 1.2 strong cipher suites" on page 1839](#). Use of strong cipher suites may cause compatibility issues.

If you are doing...	And your deployment includes...	Do this...
A new installation of Deep Security Manager 11.1 or higher	Only 10.0 and higher Deep Security Agents, Relays, and Virtual Appliances	Nothing. By default, TLS 1.2 is used between all components and enforced on the manager and relays.
	Pre-9.6 Deep Security Agents, Relays, or Virtual Appliances	(Recommended.) Upgrade all of your components to 9.6 or higher versions which support TLS 1.2. See "Upgrade components to use TLS 1.2" on page 1829 . This is the best option to increase the security of your deployment.

If you are doing...	And your deployment includes...	Do this...
		Alternatively, you can enable early TLS 1.0 to ensure backward compatibility with older components. See "Enable early TLS (1.0)" on page 1835 .
An upgrade to Deep Security Manager 11.1 or higher	Only 10.0 and higher Deep Security Agents, Relays, or Virtual Appliances	<p>(Recommended.) Enable TLS 1.2 enforcement to increase the security of your deployment. See "Enforce TLS 1.2" on page 1831.</p> <p>Alternatively, you can do nothing. Whatever your TLS settings were in your previous deployment are preserved. If you had enforced TLS 1.2 before, then your enforcement settings are preserved after the upgrade. Conversely, if you had disabled enforcement, then those settings are preserved as well.</p>
	Pre-9.6 Deep Security Agents, Relays, or Virtual Appliances	<p>(Recommended.) Although no immediate action is required, you should plan to upgrade older components to 9.6 or higher which support TLS 1.2, and then enforce TLS 1.2. See "Upgrade components to use TLS 1.2" on page 1829 and "Enforce TLS 1.2" on page 1831. This is the best option to increase the security of your deployment.</p> <p>Alternatively, you can do nothing. Whatever your TLS settings were in your previous deployment are preserved. If TLS 1.0 was allowed before, then it will also be allowed after the upgrade.</p>

Topics on this page:

- ["TLS 1.2 architectures" on the next page](#)
- ["Upgrade components to use TLS 1.2" on page 1829](#)
- ["Enforce TLS 1.2" on page 1831](#)
- ["Enable early TLS \(1.0\)" on page 1835](#)
- ["Determine whether TLS 1.2 is enforced" on page 1837](#)

- ["Guidelines for deploying agents, virtual appliances, and relays after TLS 1.2 is enforced" on page 1838](#)

TLS 1.2 and Deep Security Agent Compatibility

Deep Security Agents version 10.0 or later installed on any platform communicate with Deep Security Manager over TLS 1.2.

In addition, Deep Security Agents version 9.6 installed on the following platforms communicate with Deep Security Manager over TLS 1.2:

- Windows 2000
- Linux Debian 6
- SuSE 10. Note that the Deep Security Agent 9.6 support extension for this platform expired on 23-May-2021.
- Ubuntu 12.04

TLS 1.2 is also supported on Deep Security Agents version 9.0 on the following platforms:

- AIX. Note that the Deep Security Agent 9.0 support extension for this platform expired on 31-Dec-2020.
- Solaris. Note that the Deep Security Agent 9.0 support extension for this platform expired on 31-Dec-2019.

TLS 1.2 architectures

The diagrams below show the TLS communication in the Deep Security architecture.

Figure 1 shows the TLS communication when TLS 1.2 *is* enforced (This is the default for new 11.1 or higher Deep Security Manager installations.) You can see that the 9.5 agents can no longer communicate with Deep Security Manager, and neither can older third-party applications.

Figure 2 shows the TLS communication when TLS 1.2 is *not* enforced. You can see that Deep Security Agent 9.6 or later can communicate with Deep Security Manager over TLS 1.2, while 9.5 versions communicate over early TLS. Similarly, newer third-party applications use TLS 1.2, while older ones use early TLS.

Figure 1: TLS 1.2 is enforced

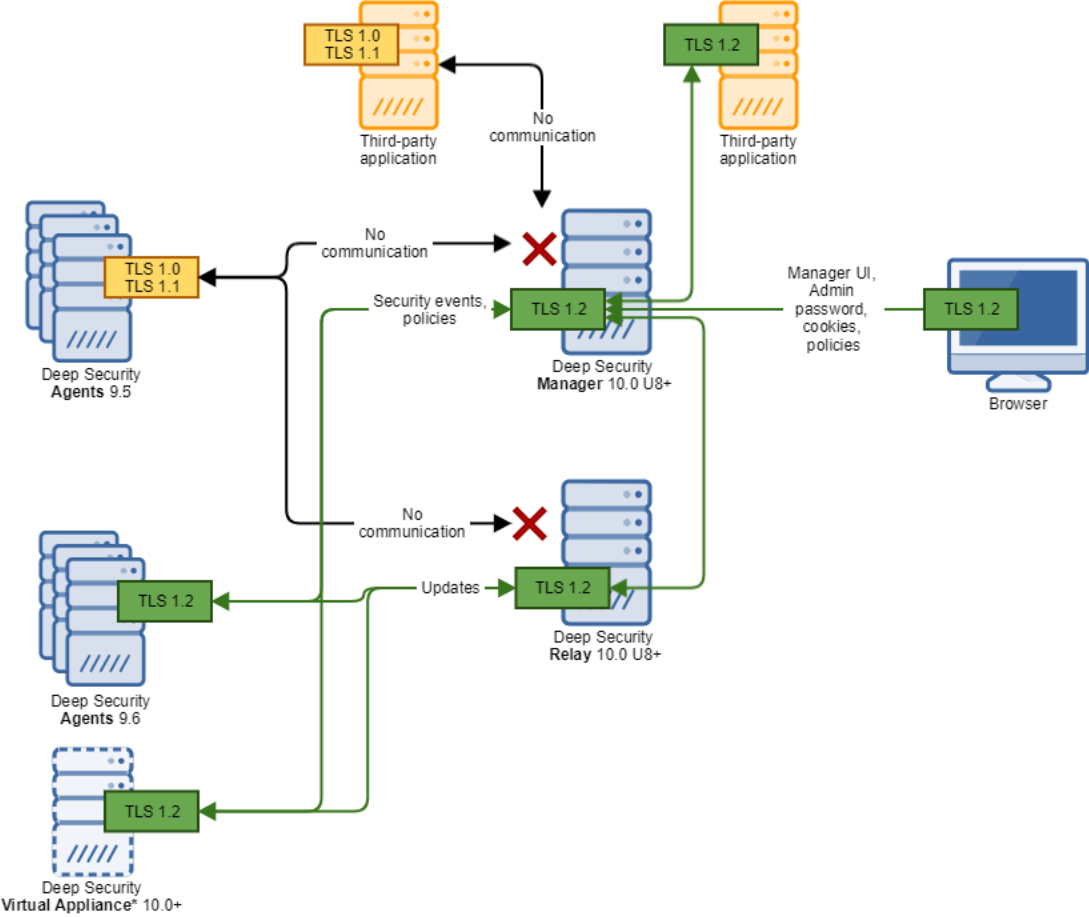

*Only available in on-premise deployments

Figure 2: TLS 1.2 is *not* enforced

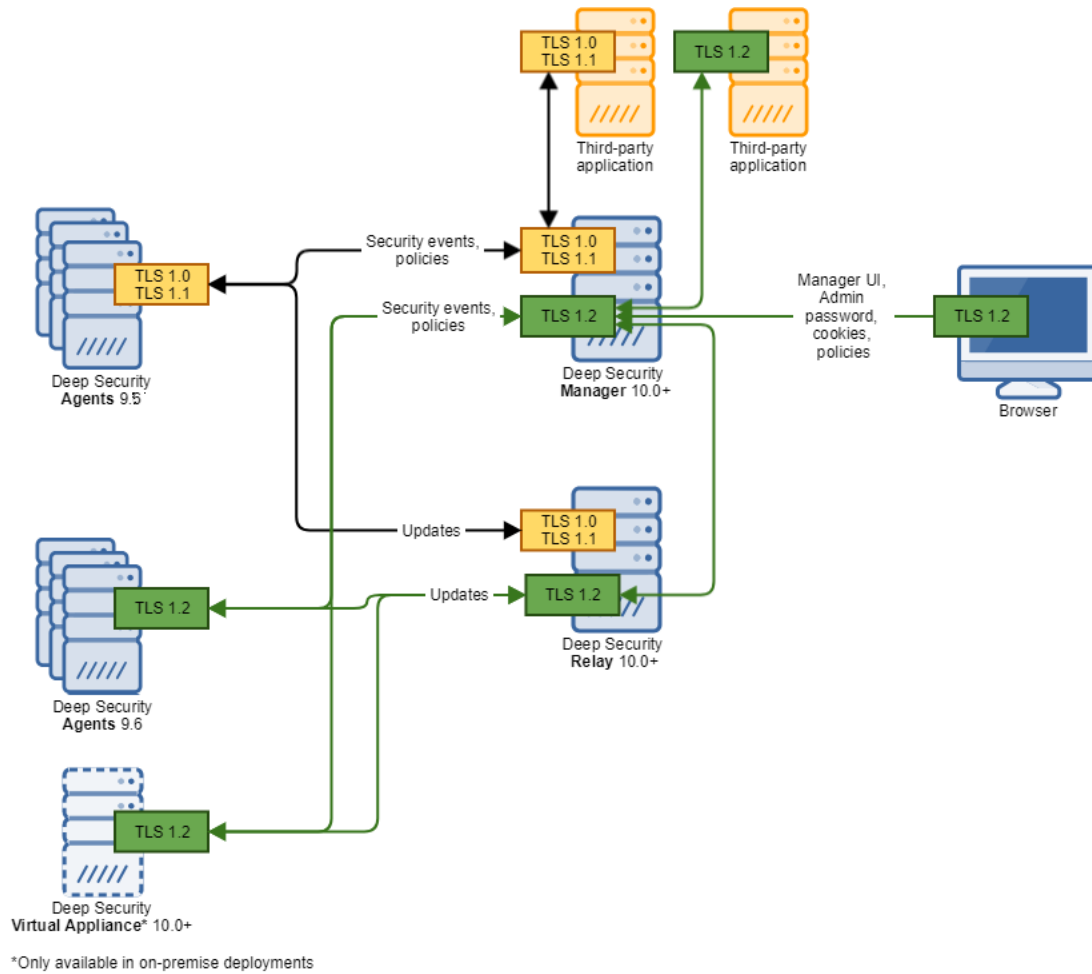

Upgrade components to use TLS 1.2

If you want your Deep Security components to use TLS 1.2, just make sure that each component supports TLS 1.2.

Follow the instructions below to verify that your Deep Security components support TLS 1.2 and upgrade them if needed.

Note: If you want to *enforce* TLS 1.2 and prevent the use of early TLS, see instead ["Enforce TLS 1.2"](#) on page 1831.

Verify and upgrade your Deep Security Manager

- Make sure you're using one of the following versions of Deep Security Manager, and if not, upgrade it:
 - Use Deep Security Manager 10.0 *update 8* or later if you're planning to "[Enforce TLS 1.2](#)" on the next page on the manager. Only 10.0 update 8 and later managers support TLS 1.2 enforcement.
 - Use Deep Security Manager 10.0 or later if you're *not* planning to "[Enforce TLS 1.2](#)" on the next page on the manager. Only 10.0 and later managers support TLS 1.2 communication.
- For upgrade instructions see "[Upgrade Deep Security Manager](#)" on page 1619.

Verify your Deep Security Manager database

- If you're using Microsoft SQL Server as your Deep Security Manager database, make sure the database supports TLS 1.2, and if not, upgrade it. See [this Microsoft article](#) for guidance.
- If you're using a PostgreSQL database, it supports TLS 1.2 so no action is necessary.
- If you're using an Oracle database, only Oracle's native encryption is supported for database-manager communication, not TLS, so no action is necessary.
- By default, there is no encryption between the database (SQL Server, PostgreSQL, or Oracle) and Deep Security Manager. You can [enable it manually](#).

Verify your Deep Security Agents

- If you have existing Deep Security Agents, make sure they're at version 10.0 or higher. Only 10.0 or higher agents support TLS 1.2.

Note: If some agents are left un-upgraded (that is, they are pre-10.0), those agents communicate over early TLS, and you may need to enable early TLS. For details, see "[Enable early TLS \(1.0\)](#)" on page 1835.

To upgrade your agents, see "[Upgrade Deep Security Agent](#)" on page 1625.

Verify your Deep Security Relays

- Make sure you're using one of the following versions of Deep Security Relay, and if not, upgrade it:
 - Use Deep Security Relay 10.0 *update 8* or later if you're planning to ["Enforce TLS 1.2" below](#) on the relay. Only 10.0 update 8 and higher relays support TLS 1.2 enforcement.
 - Use Deep Security Relay 10.0 or later if you're *not* planning to ["Enforce TLS 1.2" below](#) on the relay. Only 10.0 and higher relays support TLS 1.2 communication.

To upgrade a relay, see ["Upgrade Deep Security Relay" on page 1624](#).

Verify your Deep Security Virtual Appliance

Make sure you're using Deep Security Virtual Appliance 10.0 or higher.

To upgrade the appliance:

1. Temporarily [enable early TLS \(1.0\)](#).
2. Upgrade the appliance to 10.0 or higher (see ["Upgrade an existing appliance SVM automatically" on page 1637](#)). The new virtual appliance now supports TLS 1.2.
3. Once the upgrade is finished, [re-enable TLS 1.2 enforcement](#).

Note: The minimum VSphere and NSX software versions required for the virtual appliance already support TLS 1.2. See ["System requirements" on page 329](#) for details.

Enforce TLS 1.2

Topics in this section:

- ["Where can TLS 1.2 be enforced?" on the next page](#)
- ["What happens when TLS 1.2 enforced?" on the next page](#)
- ["Is TLS 1.2 enforced by default?" on the next page](#)
- ["Under what circumstances is TLS 1.2 enforcement possible? " on the next page](#)
- ["Enforce TLS 1.2 on Deep Security Manager" on the next page](#)
- ["Enforce TLS 1.2 on the Deep Security Relay" on page 1833](#)

- ["Enforce TLS 1.2 on just the manager's GUI port \(4119\)" on the next page](#)
- ["Test that TLS 1.2 is enforced" on page 1834](#)

Where can TLS 1.2 be enforced?

There are two enforcement points:

- on the Deep Security Manager
- on the Deep Security Relays

What happens when TLS 1.2 is enforced?

When TLS 1.2 is enforced, the manager and relays stop accepting early TLS connections, and any applications that try to use early TLS are denied access and cease to function properly.

If you choose *not* to enforce TLS 1.2, the manager and relays still accept early TLS as well as TLS 1.2 connections. This means that both older and newer applications are able to connect.

Is TLS 1.2 enforced by default?

- If you have a new installation of Deep Security Manager 11.1 or higher (not an upgrade), TLS 1.2 is enforced by default.
- If you are upgrading an existing Deep Security Manager to 11.1 or higher, then your existing TLS settings are preserved, so if TLS was not enforced previously, it will continue to not be enforced after the upgrade. Conversely, if it was enforced, it will continue to be enforced.

Under what circumstances is TLS 1.2 enforcement possible?

You can only enforce TLS 1.2 if *all* Deep Security Agents have been upgraded to 10.0 or higher, which is the version at which TLS 1.2 is supported.

Enforce TLS 1.2 on Deep Security Manager

1. Before you begin:
 - Make sure that Deep Security Manager is at version *10.0 Update 8* or higher. You need this version to enforce TLS 1.2.

- Make sure that all other components support TLS 1.2. See ["Upgrade components to use TLS 1.2" on page 1829](#).
2. On the Deep Security Manager computer, run this [dsm_c command](#):

```
dsm_c -action settlsprotocol -MinimumTLSProtocol ShowValue
```

A TLS version appears. This is the minimum TLS version that Deep Security Manager currently accepts.

3. Run this [dsm_c](#) command:

```
dsm_c -action settlsprotocol -MinimumTLSProtocol TLSv1.2
```

This command sets the minimum TLS version to 1.2. Deep Security Manager now accepts TLS 1.2 connections and disallows TLS 1.0 connections.

The Deep Security Manager service is restarted automatically.

Enforce TLS 1.2 on the Deep Security Relay

1. Before you begin:
 - Make sure that Deep Security Relay is at version *10.0 Update 8* or higher. You need this version to enforce TLS 1.2.
 - Make sure that all your components support TLS 1.2. See ["Upgrade components to use TLS 1.2" on page 1829](#).
 - Make sure that you have [enforced TLS 1.2 on Deep Security Manager](#).
2. Resend the policies associated with your relays:
 - a. In Deep Security Manager, click **Computers** and find one of your relays in the list of computers. If you're not sure which ones are your relays, at the top, click **Administration**. On the left, expand **Updates** and then click **Relay Management**. In the main pane, expand a relay group to see your relays.
 - b. Double-click the relay in the list of computers.
 - c. In the main pane, click the **Actions** tab.
 - d. Click **Send Policy** to resend the policy.
 - e. Resend the policy to each of your relays.

Enforce TLS 1.2 on just the manager's GUI port (4119)

Only read this section if you were unable to do a full enforcement on the Deep Security Manager and Relays as described previously in ["Enforce TLS 1.2 on Deep Security Manager" on the](#)

[previous page](#) and "[Enforce TLS 1.2 on the Deep Security Relay](#)" on the [previous page](#).

This section describes how to set the minimum TLS version to TLS 1.2 on port 4119. Applications that connect on port 4119 are typically web browsers and Deep Security API clients. Older Deep Security components that do not support TLS 1.2 can continue to connect to the manager (on port 4120, by default) using TLS 1.0.

1. On Deep Security Manager, enable TLS 1.0 by running this [dsm_c command](#):

```
dsm_c -action settlsprotocol -MinimumTLSProtocol TLSv1
```

Deep Security Manager now accepts TLS 1.0 connections from older agents and applications.

2. Disable early TLS on the manager's GUI port (4119) (it is possible that it's already disabled):
 - a. Open the `configuration.properties` file in the root of the Deep Security Manager installation directory.
 - b. Under `serviceName=`, look for the `protocols=` setting.

This setting defines the protocols that can be used to connect to Deep Security Manager when it is acting as a server to web browsers and Deep Security API clients.
 - c. If the `protocols=` setting is present, remove it so that only TLS 1.2 is allowed on port 4119.
 - d. Save the file.
3. Restart the Deep Security Manager service.

Test that TLS 1.2 is enforced

1. On a Deep Security component where early TLS 1.2 is enforced, run the following nmap command:

```
nmap --script ssl-enum-ciphers <ds_host> -p <ds_port> -Pn
```

where:

- `<ds_host>` is replaced with the IP address or hostname of the manager or relay
- `<ds_port>` is replaced with the listening port where TLS is being used (4119 for manager, 4122 for the relay, and 4118 for the agent—if manager-initiated activation is used)

The response should only list TLS 1.2. Example response:

```
PORT STATE SERVICE
443/tcp open https
| ssl-enum-ciphers:
| | TLSv1.2:
| ciphers:
| TLS_ECDHE_RSA_WITH_AES_256_GCM_SHA384 (secp256r1) - A
| TLS_ECDHE_RSA_WITH_AES_128_GCM_SHA256 (secp256r1) - A
| TLS_ECDHE_RSA_WITH_AES_256_CBC_SHA384 (secp256r1) - A
| TLS_ECDHE_RSA_WITH_AES_128_CBC_SHA256 (secp256r1) - A
| TLS_RSA_WITH_AES_256_GCM_SHA384 (rsa 2048) - A
| TLS_RSA_WITH_AES_128_GCM_SHA256 (rsa 2048) - A
| TLS_RSA_WITH_AES_256_CBC_SHA256 (rsa 2048) - A
| TLS_RSA_WITH_AES_128_CBC_SHA256 (rsa 2048) - A
| TLS_RSA_WITH_AES_256_CBC_SHA (rsa 2048) - A
| TLS_RSA_WITH_AES_128_CBC_SHA (rsa 2048) - A
| TLS_RSA_WITH_3DES_EDE_CBC_SHA (rsa 2048) - C
| compressors:
```

Enable early TLS (1.0)

By default, early TLS (1.0) is disabled. You'll need to enable it if you have a *new* installation of Deep Security Manager 11.1 or higher (not an upgrade) and:

- you are using pre-10.0 agents. These only support early TLS. [Go here](#) to see if a 10.0 or higher agent is available for your OSs.
- you are using third-party components that are older and need to use early TLS to communicate with Deep Security Manager.
- you are using a pre-10.0 version of the Deep Security Virtual Appliance (which is no longer supported).

To enable early TLS (1.0), follow the instructions below.

Enable TLS 1.0 on Deep Security Manager and the Deep Security Relay

1. On the Deep Security Manager computer, run this [dsm_c command](#):

```
dsm_c -action settlsprotocol -MinimumTLSProtocol ShowValue
```

A TLS version appears. This is the minimum TLS version that Deep Security Manager currently accepts.

2. Run this `dsm_c` command:

```
dsm_c -action settlsprotocol -MinimumTLSProtocol TLSv1
```

This command sets the minimum TLS version to 1.0.

TLS 1.0 is now re-enabled on your Deep Security Manager.

The Deep Security Manager service is restarted automatically.

3. Resend the policies associated with your relays:
 - a. In Deep Security Manager, click **Computers** and find one of your relays in the list of computers. If you're not sure which ones are your relays, at the top, click **Administration** on the left, expand **Updates** and then click **Relay Management**. In the main pane, expand a relay group to see your relays.
 - b. Double-click the relay in the list of computers.
 - c. In the main pane, click the **Actions** tab.
 - d. Click **Send Policy** to resend the policy.
 - e. Resend the policy to each of your relays.

TLS 1.0 is now re-enabled on your relays.

Enable TLS 1.0 on the manager's GUI port (4119)

Read this section if you previously enforced TLS 1.2 only on the manager's GUI port (4119) and now want to re-enable early TLS 1.0 on this port.

1. Follow the instructions in "[Enable TLS 1.0 on Deep Security Manager and the Deep Security Relay](#)" above. This re-enables TLS 1.0 on the GUI port (4119).

Enable TLS 1.0 in deployment scripts

Deep Security Agents and Deep Security Relays can be deployed using [deployment scripts](#). You may need to modify these scripts as follows:

1. If you are deploying onto Windows XP, 2003, or 2008, remove these lines from the deployment script:

```
#requires -version 4.0
```

```
[Net.ServicePointManager]::SecurityProtocol =  
[Net.SecurityProtocolType]::Tls12;
```

Windows XP, 2003, and 2008 do not support PowerShell 4.0, which is required for TLS 1.2.

2. If you are deploying onto Red Hat Enterprise Linux 6, remove this tag from the deployment script:

```
--tls1.2
```

Red Hat Enterprise Linux 6 uses curl 7.19 by default which does not support TLS 1.2.

3. If you are deploying onto any other supported operating system, leave the deployment scripts as they are.

Determine whether TLS 1.2 is enforced

If you're not sure whether TLS 1.2 is enforced on Deep Security Manager, follow the instructions below to find out.

1. On the Deep Security Manager computer, open a command prompt and run the following [dsm_c command](#):

```
dsm_c -action settlsprotocol -MinimumTLSProtocol ShowValue
```

The minimum TLS protocol accepted by the manager is displayed. If it shows TLS 1.2, then TLS 1.2 is enforced. If it shows TLS 1.0, then early TLS is allowed and TLS 1.2 is not enforced.

Determining whether TLS 1.2 is enforced on the relay is harder. If you pushed out your TLS settings to the relay through policy according to ["Enforce TLS 1.2 on the Deep Security Relay" on page 1833](#) or ["Enable TLS 1.0 on Deep Security Manager and the Deep Security Relay" on the previous page](#), then those TLS settings apply to the relay. If you did not push out TLS

settings through policy, then the relay's default TLS settings apply. The relay's default settings depend on its version: if you're using an 11.1 or higher relay, then TLS 1.2 is enforced by default. For pre-11.1 relays, TLS 1.2 is not enforced by default.

Guidelines for deploying agents, virtual appliances, and relays after TLS 1.2 is enforced

This section discusses special considerations when deploying agents, virtual appliances and relays when TLS 1.2 is enforced. If you [enabled early TLS \(1.0\)](#), then there are no special considerations, and you do not need to read this section.

Topics in this section:

- ["Guidelines for deploying agents, virtual appliances, and relays when TLS 1.2 is enforced" below](#)
- ["Guidelines for using deployment scripts when TLS 1.2 is enforced" below](#)

Guidelines for deploying agents, virtual appliances, and relays when TLS 1.2 is enforced

- You must deploy 10.0 or higher agents, virtual appliances, and relays. Only 10.0 or higher agents and relays support TLS 1.2.
- If you need to deploy a 9.6 or earlier agent or relay you must [enable early TLS \(1.0\)](#).

Guidelines for using deployment scripts when TLS 1.2 is enforced

If TLS 1.2 is enforced, you can install 10.0 or higher agents and relays using [deployment scripts](#). Below are some guidelines to ensure the deployment scripts work:

1. If you are deploying an agent or relay onto Windows computers, use PowerShell 4.0 or higher, which supports TLS 1.2.
2. If you are deploying an agent or relay onto Linux, use curl 7.34.0 or higher, which supports TLS 1.2.
3. If you are deploying onto Windows XP, 2003, or 2008

OR

If you are deploying onto Red Hat Enterprise Linux 6

...these OSs don't support TLS 1.2 and you must ["Enable early TLS \(1.0\)" on page 1835](#) and [modify your deployment scripts](#).

Enable TLS 1.2 strong cipher suites

Enabling strong cipher suites allows you to be certain that all of the communications to and from your Deep Security components are secure. If a malicious user were to create a connection to your system over a communications channel that uses weak cipher suites, this person could exploit the known weaknesses in these suites to put your system and information at risk.

This page describes how to update the Deep Security Manager, Deep Security Agent and Deep Security Relay so that they use the TLS 1.2 strong cipher suites. These cipher suites have an Advanced+ (A+) rating, and are listed in the table on [this page](#).

Step 1: ["Check your environment" below](#)

Step 2: ["Update Deep Security components" on the next page](#)

Step 3: ["Run a script to enable TLS 1.2 strong cipher suites" on the next page](#)

Step 4: ["Verify that the script worked" on page 1841](#)

["Disable TLS 1.2 strong cipher suites" on page 1843](#)

Check your environment

There are some circumstances where you should not enable strong cipher suites and should [use TLS 1.2 with Deep Security](#) instead:

- If you are using [FIPS mode](#).
- If any of the computers in your environment are running Windows Server 2012 R2 or earlier, which doesn't support strong cipher suites. Consider upgrading those computers to Windows Server 2016, which does support strong cipher suites.
- If you can't upgrade all of your Deep Security components to 12.0 or later. For example, if you're using operating systems for which a 12.0 agent is not available.

Update Deep Security components

Make sure you update all components in the following order; otherwise the agents cannot communicate with the relays and manager:

1. Update all your manager instances to 12.0 or a later update. For upgrade instructions, see ["Install Deep Security Manager" on page 442](#).
2. Update all your relays to 12.0 or later. To upgrade a relay, follow the same process as upgrading an agent:
 - a. Import the latest relay software into the manager, either manually or automatically. See ["Import agent software" on page 499](#) for details.
 - b. Upgrade the relay. See ["Upgrade Deep Security Relay" on page 1624](#).
3. Update all your agents to 12.0 or later. To upgrade your agents:
 - a. Import the latest agent software into the manager, either manually or automatically. See ["Import agent software" on page 499](#) for details.
 - b. Upgrade your Deep Security Agents. See ["Upgrade Deep Security Agent" on page 1625](#).

Run a script to enable TLS 1.2 strong cipher suites

1. Copy the `EnableStrongCiphers12.script` file available at <https://github.com/deep-security/ops-tools/tree/master/deepsecurity/manager> to:
 - On Windows: `<Manager_root>\Scripts`
 - On Linux: `<Manager_root>/Scripts`

where `<Manager_root>` is replaced with the path to your manager's installation directory, by default:

- `C:\Program Files\Trend Micro\Deep Security Manager` (Windows)
- `/opt/dsm/` (Linux)

Note: If you do not see a `\Scripts` directory, create it.

2. Log in to the manager.
3. Click **Administration** at the top.
4. On the left, click **Scheduled Tasks**.
5. In the main pane, click **New**.
6. The **New Scheduled Task Wizard** appears.
7. From the **Type** drop-down list, select **Run Script**. Select **Once Only**. Click **Next**.

8. Accept the date, time, and time zone defaults, and then click **Next**.
9. For the **Script**, select **EnableStrongCiphers.script**. Click **Next**.
10. For the **Name**, enter a name for the script, for example, `Enable Strong Cipher Suites`. Make sure **Task Enabled** is selected. Click **Run Task on 'Finish'**. Click **Finish**.

The script runs.

11. Restart the Deep Security Manager service.

Your agents, relays, and manager should now be communicating with each other using TLS 1.2 strong cipher suites exclusively.

Verify that the script worked

To verify that the script worked, and that only strong TLS 1.2 cipher suites are permitted, you must run a series of nmap commands.

- ["Verify the manager using nmap" below](#)
- ["Verify the relays using nmap" on the next page](#)
- ["Verify the agents using nmap" on page 1843](#)

Verify the manager using nmap

Run the following command:

```
nmap --script ssl-enum-ciphers -p 4119 <Manager_FQDN>
```

The output should look similar to the following, with the strong cipher suites near the middle:

```
Starting Nmap 7.01 ( https://nmap.org ) at 2018-11-14 09:51 EST
```

```
Nmap scan report for <DSM FQDN> (X.X.X.X)
```

```
Host is up (0.0049s latency).
```

```
PORT STATE SERVICE
```

```
4119/tcp open  assuria-slm
```

```
| ssl-enum-ciphers:
```

```
| TLSv1.2:
```

```
| ciphers:
```

```
| TLS_ECDHE_RSA_WITH_AES_128_GCM_SHA256 (secp256k1) - A
```

```
| TLS_ECDHE_RSA_WITH_AES_256_GCM_SHA384 (secp256k1) - A
| compressors:
| NULL
| cipher preference: client
|_ least strength: A
Nmap done: 1 IP address (1 host up) scanned in 6.82 seconds
```

Verify the relays using nmap

Run the following command:

```
nmap --script ssl-enum-ciphers -p 4122 <Relay_FQDN>
```

The output should look similar to the following, again, with the strong cipher suites listed near the middle:

```
Starting Nmap 7.01 ( https://nmap.org ) at 2018-11-14 09:49 EST
Nmap scan report for <DSR FQDN> (X.X.X.X)
Host is up (0.0045s latency).
PORT STATE SERVICE
4122/tcp open unknown
| ssl-enum-ciphers:
| TLSv1.2:
| ciphers:
| TLS_ECDHE_RSA_WITH_AES_256_GCM_SHA384 (secp256r1) - A
| TLS_ECDHE_RSA_WITH_AES_128_GCM_SHA256 (secp256r1) - A
| compressors:
| NULL
| cipher preference: server
|_ least strength: A
Nmap done: 1 IP address (1 host up) scanned in 31.02 seconds
```

Verify the agents using nmap

Run the following command:

```
nmap --script ssl-enum-ciphers -p 4118 <Agent_FQDN>
```

The output looks similar to the following:

```
Starting Nmap 7.01 ( https://nmap.org ) at 2018-11-14 09:50 EST
```

```
Nmap scan report for <DSA FQDN> (X.X.X.X)
```

```
Host is up (0.0048s latency).
```

```
PORT STATE SERVICE
```

```
4118/tcp open netscript
```

```
| ssl-enum-ciphers:
```

```
| TLSv1.2:
```

```
| ciphers:
```

```
| TLS_ECDHE_RSA_WITH_AES_256_GCM_SHA384 (secp256r1) - A
```

```
| TLS_ECDHE_RSA_WITH_AES_128_GCM_SHA256 (secp256r1) - A
```

```
| compressors:
```

```
| NULL
```

```
| cipher preference: server
```

```
|_ least strength: A
```

```
Nmap done: 1 IP address (1 host up) scanned in 2.72 seconds
```

Disable TLS 1.2 strong cipher suites

If you mistakenly run the script before upgrading all of your agents, relays, or the manager, you can revert this action by doing the following:

1. Open the `configuration.properties` file in `<Manager_root>`, and remove the line starting with `ciphers`. The line looks similar to the following:

```
ciphers=TLS_ECDHE_RSA_WITH_AES_256_GCM_SHA384, TLS_ECDHE_RSA_WITH_AES_128_GCM_SHA256, TLS_ECDHE_RSA_WITH_AES_256_CBC_SHA384, TLS_ECDHE_RSA_WITH_AES_128_CBC_SHA256
```

2. Add the following values to the `protocols` field: `TLSv1` and `TLSv1.1`. Your final property looks similar to this:

```
protocols = TLSv1, TLSv1.1, TLSv1.2
```

3. Save and close the file.
4. Open the `java.security` file in `<Manager_root>\jre\lib\security\` and remove the following two protocols from `jdk.tls.disabledAlgorithms`:

```
TLSv1, TLSv1.1
```

5. On Deep Security Manager, run the following `dsm_c` commands:

```
dsm_c -action changesetting -name settings.configuration.restrictRelayMinimumTLSProtocol -value TLSv1
```

```
dsm_c -action changesetting -name settings.configuration.enableStrongCiphers -value false
```

Your system should now be able to communicate again. If you still need to enable TLS 1.2 strong cipher suites, make sure you have upgraded all components before running the script.

If you continue to experience communication problems with the Deep Security Manager, run the following additional `dsm_c` command:

```
dsm_c -action changesetting -name settings.configuration.MinimumTLSProtocolNewNode -value TLSv1
```

Legal disclosures

Privacy and personal data collection disclosure

Certain features available in Trend Micro products collect and send feedback regarding product usage and detection information to Trend Micro. Some of this data is considered personal in certain jurisdictions and under certain regulations. If you do not want Trend Micro to collect personal data, you must ensure that you disable the related features.

The following link outlines the types of data that Trend Micro Deep Security collects and provides detailed instructions on how to disable the specific features that feed back the information.

<https://success.trendmicro.com/data-collection-disclosure>

Data collected by Trend Micro is subject to the conditions stated in the Trend Micro Privacy Policy:

https://www.trendmicro.com/en_us/about/legal/privacy.html

Deep Security Product Usage Data Collection

Trend Micro collects protected performance and feature usage data to help improve Deep Security Manager. Trend Micro only uses the collected data internally for product improvement; it is not shared with external parties and does not contain any personally identifiable information.

As the data allows Trend Micro to more effectively support Deep Security, we recommend that you leave data collection enabled. However, if you do not want Deep Security Manager to collect this data, you can disable data collection.

To disable data collection, go to **System Settings > Advanced > Product Usage Data Collection** and deselect **Enable Product Usage Data Collection**.

Legal disclaimer

Below are the legal disclaimers regarding the following releases:

- ["Hot Fix" below](#)
- ["Major release, Update, Patch or Service Pack" on the next page](#)

Hot Fix

This hot fix was developed as a workaround or solution to a customer-reported problem. As such, this hot fix has received limited testing and has not been certified as an official product update.

Consequently, THIS HOT FIX IS PROVIDED "AS IS". TREND MICRO MAKES NO WARRANTY OR PROMISE ABOUT THE OPERATION OR PERFORMANCE OF THIS HOT FIX NOR DOES IT WARRANT THAT THIS HOT FIX IS ERROR FREE. TO THE FULLEST EXTENT PERMITTED BY LAW, TREND MICRO DISCLAIMS ALL IMPLIED AND

STATUTORY WARRANTIES, INCLUDING BUT NOT LIMITED TO THE IMPLIED WARRANTIES OF MERCHANTABILITY, NON INFRINGEMENT AND FITNESS FOR A PARTICULAR PURPOSE.

Major release, Update, Patch or Service Pack

This release was current as of the release date. However, all customers are advised to check Trend Micro's website for documentation updates.

Tip: Register online with Trend Micro within 30 days of installation to continue downloading new pattern files and product updates from the Trend Micro website. Register during installation or online at <https://clp.trendmicro.com/FullRegistration?T=TM>.

Integrations

Integrate with AWS Control Tower

Integrate Deep Security with [AWS Control Tower](#) to ensure that every account added through Control Tower Account Factory is automatically provisioned in Deep Security, providing centralized visibility to the security posture of EC2 instances deployed in each account as well as the foundation for policy and billing automation.

Overview

The Lifecycle Hook solution provides a CloudFormation template which, when launched in the Control Tower Master Account, deploys AWS infrastructure to ensure Deep Security monitors each Account Factory AWS account automatically. The solution consists of 2 Lambda functions; one to manage our role and access Deep Security, and another to manage the lifecycle of the first Lambda. AWS Secrets Manager is leveraged to store the API key for Deep Security in the Master account and a CloudWatch Events rule is configured to trigger the customization Lambda when a Control Tower account is successfully deployed.

Once Deep Security is integrated with AWS Control Tower, it will be implemented in the following way:

1. During stack launch, the lifecycle Lambda is executed for each existing Control Tower Account, including the Control Tower Master, Audit, and Log accounts.
2. After launch, a CloudWatch Event rule triggers the lifecycle Lambda for each successful Control Tower CreateManagedAccount event.
3. The lifecycle Lambda function retrieves the Deep Security Api Key from AWS Secrets Manager, then gets the External ID for your organization from the Deep Security API.
4. The Lambda function assumes the ControlTowerExecution role in the target Managed Account in order to create the necessary cross account role and associated policy.
5. A call is made to the Deep Security API to add this Managed Account to your tenant.

Integrate with AWS Control Tower

1. Deploy Deep Security Manager to the AWS Control Tower designated shared security account. We recommend deploying [Deep Security Quickstart](#) into your Control Tower Security account and leveraging a public facing ELB in the quickstart deployment to create connectivity between workloads Managed Accounts and the Deep Security Manager.
2. When the CloudFormation stack has launched successfully, record the DeepSecurityConsole value from the top level CloudFormation template. You will need this URL to sign in to the console and to configure the multi-account integration.
3. In Deep Security Manager, go to **Administration > User Management > API Keys** and click **New**. Select a name for the key and the **Full Access** role. Be sure to save the key as it cannot be retrieved later. This key will be used to authenticate the automation from the AWS Control Tower Master to the console API. For more information, see ["Create an API key for a user" on page 1505](#).
4. Sign in to the AWS Control Tower master account. Navigate to the CloudFormation Service, select the region in which AWS Control Tower was deployed, and launch the [lifecycle template](#).
5. In the lifecycle template, enter your API Key generated in step 3. Next, enter the FQDN of your console (without https://) which was displayed as the DeepSecurityConsole value recorded in step 2.
6. Select the box acknowledging that AWS CloudFormation might create IAM resources. Select **Create Stack**, and the integration will start adding your AWS accounts to Deep Security.
7. Once all your accounts have been imported, ["Install the agent" on page 515](#) and activate protection.

Upgrade the AWS Control Tower integration

As new capabilities are added to Deep Security, it might be necessary to update the permissions for the application's cross-account role. To update the role deployed by the lifecycle hook, update the Deep Security stack with the latest template, which can be found at its original URL. The parameter values should not be modified from their original values unless directed by Trend Micro Support. Updating the CloudFormation stack will update the role used by all existing accounts and the role created for future enrollments.

Remove AWS Control Tower integration

To remove the lifecycle hook, identify and delete the CloudFormation stack. Protection for Managed Accounts which have already been added will remain in place. For details on removing an AWS account from Deep Security see, ["Remove an AWS account" on page 656](#).

Integrate with AWS Systems Manager Distributor

[AWS Systems Manager Distributor](#) is a feature integrated with AWS Systems Manager that you can use to securely store and distribute software packages in your accounts. By integrating with AWS Systems Manager Distributor, you can distribute Deep Security Agents across multiple platforms, control access to managed instances, and automate your deployments.

Create an IAM policy

Follow the instructions in [Importing existing managed policies](#).

In the **Import managed policies** window, add the "AmazonSSMManagedInstanceCore" policy.

Create a role and assign the policy

Follow the instructions in [Creating a role for an AWS service](#).

In the **Attach permissions policies** window, add the "AmazonSSMManagedInstanceCore" permission.

Create parameters

1. In your AWS console, navigate to **AWS Systems Manager > Application Management > Parameter Store**.
2. There are 4 parameters that need to be created. Click **Create parameter** and enter the **Name** and **Value** as listed in the table below. The other fields can be left on their default values.

Name	Value
dsActivationUrl	dsm://dsm.company.com:4120/
dsManagerUrl	https://dsm.company.com:443
dsTenantId	For single tenant environments, this parameter is not required. For multi-tenants, on the Deep Security Manager, go to Support > Deployment Scripts . Scroll to the bottom of the generated script and copy the <i>tenantID</i> .
dsToken	For single tenant environments, this parameter is not required. For multi-tenants, on the Deep Security Manager, go to Support > Deployment Scripts . Scroll to the bottom of the generated script and copy the <i>token</i> .

Note: Make sure the values for dsActivationUrl and dsManagerUrl are entered exactly as they appear, taking care to include the trailing slash where applicable.

Integrate with AWS Systems Manager Distributor

1. In the AWS console, go to **AWS Systems Manager > Node Management > Distributor**.
2. Select the **TrendMicro-CloudOne-WorkloadSecurity** package, then **Install on a Schedule**.
3. The **Create Association** page opens. Fill in the required fields. For **Installation Type**, we recommend you use the *In-place update* option.
4. Create a schedule. Leveraging a scheduled State Manager Association will ensure agents are always installed and up to date.

Protect your computers

We recommend configuring a [cloud connector](#) for each AWS account which will contain managed agents. It might also be necessary to [create a policy](#) specific to the systems which will be managed by Distributor.

Integrate with SAP NetWeaver

The Scanner feature enables you to protect your SAP deployments using Deep Security, helping to secure critical information from attack, including a wide variety of threats such as malware, cross-site scripting and SQL injection. Deep Security scans content uploaded to the SAP NetWeaver technology platform to determine its true type and reports this to SAP systems via the NetWeaver-VSI interface. Content scanning protects against possible malicious script content that might be embedded or disguised inside documents. SAP administrators can then set policy according to which document types should be allowed.

Note: Deep Security Scanner is not supported on computers where the Deep Security Agent is enabled as a Relay.

Note: Deep Security Scanner is not supported when FIPS mode is enabled. See ["FIPS 140 support" on page 1811](#).

How it works

1. SAP customer environments are secured through the SAP Virus Scan Interface (VSI), the security component of the SAP NetWeaver platform. The VSI is used to secure all forms of customer content including documents, embedded images, and active content including JavaScript and scripts in PDF and Office documents. The Scanner feature works seamlessly with SAP NetWeaver technology and the SAP HANA® platform.
2. The Deep Security Scanner feature scans the content uploaded to the SAP NetWeaver technology platform to determine its true type and reports this to SAP systems via the NetWeaver VSI interface. Content scanning protects against possible malicious script content that might be embedded or disguised inside documents.
3. SAP administrators can then set policy according to which actual document types should be allowed.

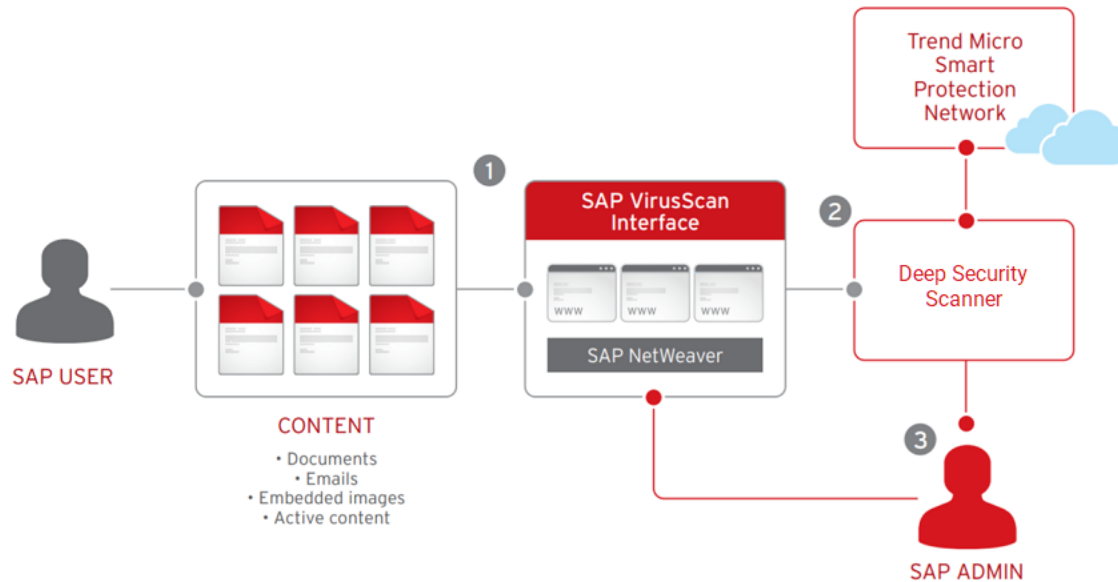

Deep Security and SAP components

Deep Security Manager connects with the Deep Security Agent located on the SAP NetWeaver server. The agent connects with `libsapvsa` or `dsvsa.dll`, which are the virus adapters provided by Trend Micro for scanning purposes.

The components involved in this solution are:

- **Deep Security Manager:** The centralized web-based management console that administrators use to configure security policy and deploy protection to the Deep Security Agent.
- **Deep Security Agent:** A security agent deployed directly on a computer. The nature of that protection depends on the rules and security settings that each Deep Security Agent receives from the Deep Security Manager.

- **SAP NetWeaver:** SAP integrated technology computing platform. The SAP NetWeaver Virus Scan Interface (NW-VSI) provides virus scanning capabilities for third-party products that perform the actual scan. The NW-VSI interface must be activated.
- **SAP NetWeaver ABAP WinGUI:** A Windows management console used for SAP NetWeaver. In this document, it is used for the configuration of the Deep Security Agent and the SAP NetWeaver Virus Scan Interface.

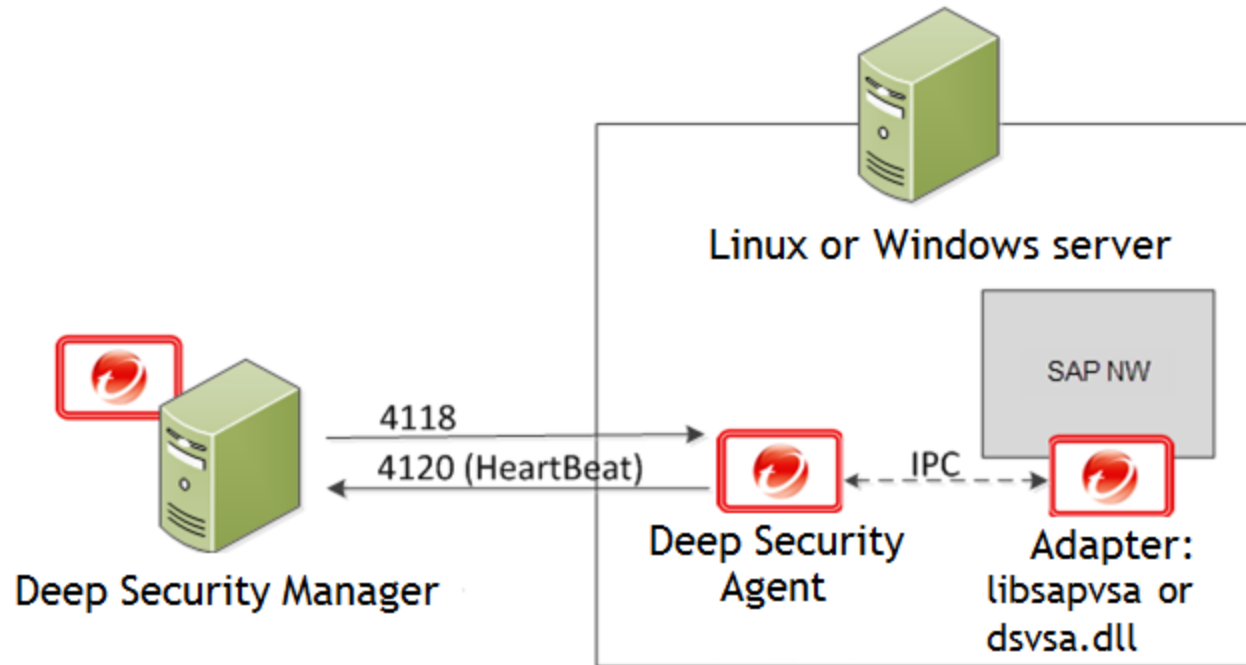

Set up the integration between Deep Security Scanner and SAP NetWeaver

1. ["Activate the Deep Security Scanner feature"](#) on the next page.
2. Check the ["Supported features by platform"](#) on page 360 to see which operating systems support the Scanner feature.

3. Install the Deep Security Agent on an SAP application server that's running one of the supported operating systems. See ["Install the agent" on the next page](#).
4. Add the SAP server to Deep Security and activate the agent on the SAP server. See ["Add the SAP Server to Deep Security Manager and activate the agent" on page 1855](#).
5. Enable the SAP integration feature in a computer or policy. See ["Assign a security profile" on page 1858](#).
6. Configure the SAP Virus Scan Interface (VSI) by calling the following transactions. See ["Configure SAP to use the agent" on page 1861](#):
 - VSCANGROUP
 - VSCAN
 - VSCANPROFILE
 - VSCANTEST

Note: Depending on your operating system and environment, the output that you see may differ slightly from what is shown in this article.

Activate the Deep Security Scanner feature

1. In the Deep Security Manager, go to **Administration > Licenses**.
2. Select **Enter New Activation Code**.
3. In the **Deep Security Scanner** area (under **Additional Features**), enter your Deep Security Scanner activation code, then select **Next** and follow the prompts.

The Settings > Scanner tab will now be available in the **Computer or Policy editor**¹, where you can enable the SAP feature for individual computers or policies.

¹You can change these settings for a policy or for a specific computer. To change the settings for a policy, go to the Policies page and double-click the policy that you want to edit (or select the policy and click Details). To change the settings for a computer, go to the Computers page and double-click the computer that you want to edit (or select the computer and click Details).

Note: In order to use the Deep Security Scanner feature, the Anti-Malware module must also be activated.

Install the agent

The Deep Security Agent is installed with core agent functionality only. After the agent is installed on SUSE Linux Enterprise Server or Red Hat Enterprise Linux, you can enable protection modules on the agent. At that point, the plug-ins required for the protection modules will be downloaded and installed.

1. Go to the Trend Micro Download Center (<http://downloadcenter.trendmicro.com>) and download the Deep Security Agent package for your OS.
2. Install the agent on the target system. You can use rpm or zypper, depending on the OS. In this example, rpm is used by typing:

```
rpm -ihv Agent-Core-SuSE_<version>.x86_64.rpm
```

3. You should see output similar to what's shown in this example, which indicates that the agent installation is complete:

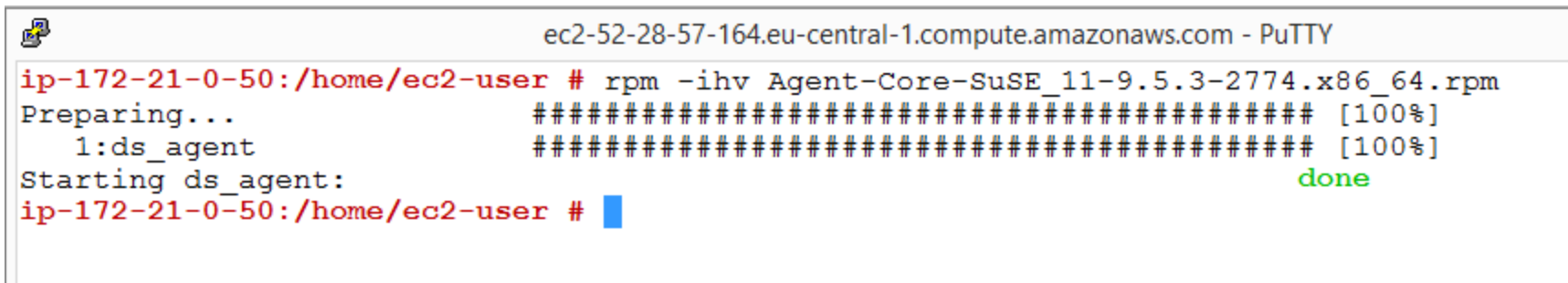

```
ec2-52-28-57-164.eu-central-1.compute.amazonaws.com - PuTTY
ip-172-21-0-50:/home/ec2-user # rpm -ihv Agent-Core-SuSE_11-9.5.3-2774.x86_64.rpm
Preparing...                               ##### [100%]
 1:ds_agent                                ##### [100%]
Starting ds_agent:                          done
ip-172-21-0-50:/home/ec2-user # █
```

Tip: You can also deploy the agent using a deployment script generated from the Deep Security Manager.

Add the SAP Server to Deep Security Manager and activate the agent

1. To add the SAP server, open the Deep Security Manager console and on the **Computers** tab, select **New**. There are several ways to add the server, including synchronization with Microsoft Active Directory, VMware vCenter, Amazon Web Services, or Microsoft Azure. You can also add the computer using an FQDN or IP address. For detailed instructions, see ["About adding computers" on page 631](#).
2. The status of your instance will be either **Unmanaged (Activation Required)** or **Unmanged (Unknown)**. Next, you will need to activate the agent before the manager can assign rules and policies to protect the computer. The activation process includes the exchange of unique fingerprints between the agent and the manager. This ensure that only one Deep Security Manager can communicate with the agent. There are two ways to activate the agent: agent-initiated or manager-initiated.
 - **Manager-initiated activation:** The manager-initiated method requires that the Deep Security Manager can connect to the FQDN or the IP of the agent via the [agent's listening port number for heartbeats](#). This can sometimes be difficult due to NAT port forwarding, firewall, or AWS security groups. To perform manager-initiated activation, go to the **Computers** tab in the Deep Security Manager console, right-click the instance where the agent is installed and select **Actions > Activate**. If you use manager-initiated activation, we strongly recommend you also ["Protect Deep Security Agent" on page 1567](#) from unauthorized Deep Security Managers.
 - **Agent-initiated activation:** The agent-initiated method requires that the Deep Security Agent can connect to the configured Deep Security Manager address via the manager's listening port number for heartbeats.

You can find the Deep Security Manager address (FQDN or IP) in the Deep Security Manager console, under **Administration > Manager Nodes**.

You will also need to enable agent-initiated activation from the Deep Security Manager console, by selecting **Administration > System Settings > Agents** and then selecting **Allow Agent-Initiated Activation**.

Next, use a locally-run command-line tool on the Deep Security Agent to initiate the activation process. The minimum activation instruction contains the activation command and the manager's URL (including the port number):

```
dsa_control -a dsm://[managerurl]:[port]/
```

where:

- `-a` is the command to activate the agent , and
- `dsm://managerurl:4120/` is the parameter that points the agent to the Deep Security Manager. ("managerurl" is the URL of the Deep Security Manager, and "4120" is the default agent-to-manager communication port.)

The manager URL is the only required parameter for the activation command. Additional parameters are also available. (For a list of available parameters, see ["Command-line basics" on page 1731.](#))

In the following example, we use the agent-initiated activation by typing:

```
/opt/ds_agent/dsa_control -a dsm://cetl-dsm.ceur-testlab.trendmicro.de:4120/
```



```
ec2-52-28-57-164.eu-central-1.compute.amazonaws.com - PuTTY
ip-172-21-0-50:/home/ec2-user # rpm -ihv Agent-Core-SuSE_11-9.5.3-2774.x86_64.rpm
Preparing...                               ##### [100%]
 1:ds_agent                               ##### [100%]
Starting ds_agent:                          done
ip-172-21-0-50:/home/ec2-user # /opt/ds_agent/dsa_control -a dsm://cetl-dsm.ceur-testlab.trendmicro.de:4120/
Starting thread 'CScriptThread' with stack size of 1048576
HTTP Status: 200 - OK
Response:
Attempting to connect to https://cetl-dsm.ceur-testlab.trendmicro.de:4120/
SSL handshake completed successfully - initiating command session.
Connected with AES256-SHA to peer at cetl-dsm.ceur-testlab.trendmicro.de
Received a 'GetHostInfo' command from the manager.
Received a 'GetHostInfo' command from the manager.
Received a 'SetDSMCert' command from the manager.
Received a 'SetAgentCredentials' command from the manager.
Received a 'GetAgentEvents' command from the manager.
Received a 'GetInterfaces' command from the manager.
Received a 'GetAgentEvents' command from the manager.
Received a 'GetAgentStatus' command from the manager.
Received a 'GetAgentEvents' command from the manager.
Received a 'SetSecurityConfiguration' command from the manager.
Received a 'GetAgentEvents' command from the manager.
Received a 'GetAgentStatus' command from the manager.
Command session completed.
ip-172-21-0-50:/home/ec2-user #
```

This output indicates that the agent activation is complete.

3. To confirm the activation, in the Deep Security Manager console, go to the **Computers** tab. Select the computer name and then select **Details** and check that the computer's status is "Managed".

Assign a security profile

At this point, the status of the agent is **Managed (Online)** but there is no protection module installed. This means that the agent and the manager are communicating but the agent is not using any configuration.

There are several ways to apply protection. In this example, the configuration is done directly on the SAP instance by activating SAP, activating Anti-Malware to provide the agent with the latest pattern and scan engine, and assigning the default **Scan Configurations**.

1. In the **Computer editor**¹, go to **Anti-Malware > General**.
2. In the **Anti-Malware** section, set **Configuration** to **On** (or **Inherited On**) and then select **Save**.

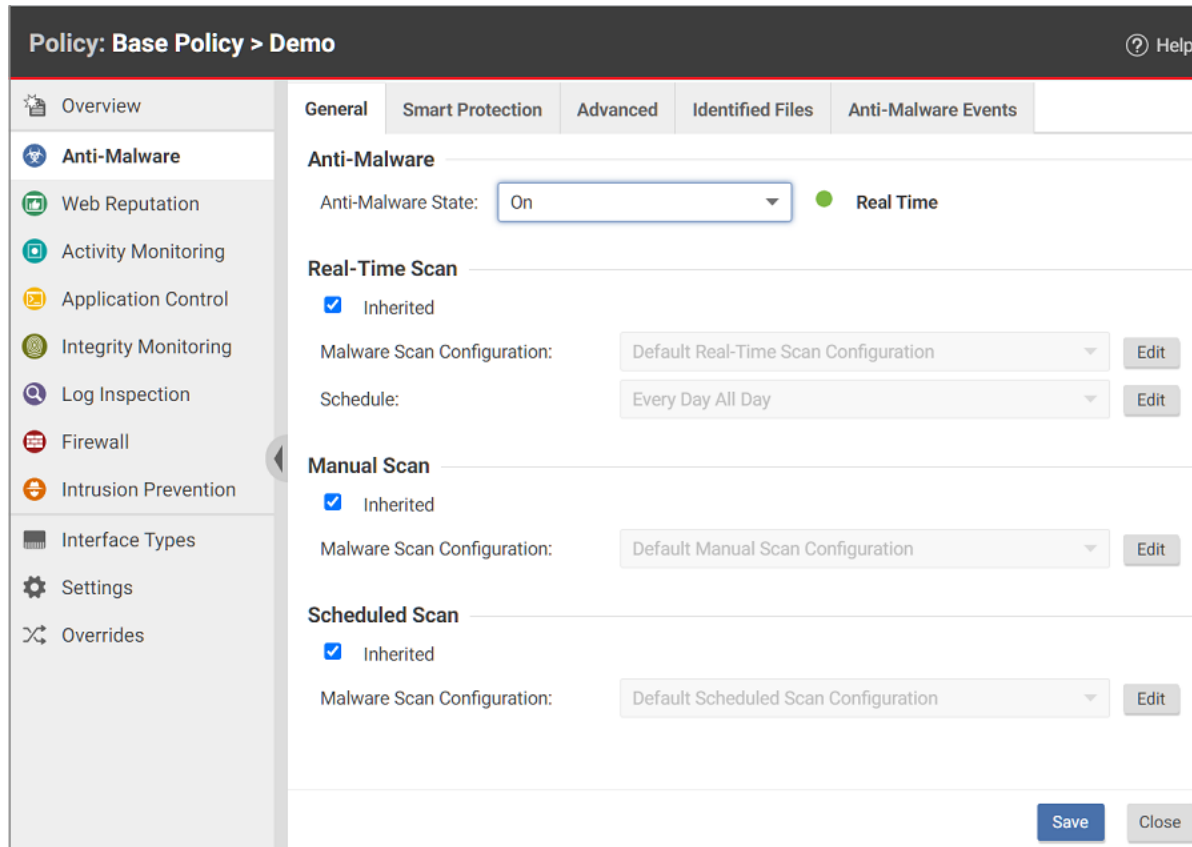

3. In the **Real-Time Scan**, **Manual Scan**, or **Scheduled Scan** sections, set the **Malware Scan Configuration** and **Schedule**, or allow those settings to be inherited from the parent policy.
4. Select **Save**. The status of the Anti-Malware module changes to **Off, installation pending**. This means that the agent is retrieving the required module from the Deep Security Manager. For this to work, the client needs to access the Deep

¹To open the Computer editor, go to the Computers page and double-click the computer that you want to edit (or select the computer and click Details).

Trend Micro Deep Security On-Premise 20

Security Relay on the [relay's listening port number](#). A few moments later, the agent should start downloading security updates such as Anti-Malware patterns and scan engines.

5. In the Computer editor, go to **Settings > Scanner**.
6. In the **SAP** section, set **Configuration** to **On** (or **Inherited On**) and then select **Save**.

After status of the agent changes to **Managed (Online)** again and the Anti-Malware and Scanner (SAP) modules are **On**, you can proceed with the SAP configuration.

The screenshot displays the 'Computer' configuration page in the Trend Micro Deep Security On-Premise 20 console. The interface is divided into a left sidebar, a top navigation bar, and a main content area.

Left Sidebar: Contains a list of modules and sections: Overview, Anti-Malware, Web Reputation, Firewall, Intrusion Prevention, Integrity Monitoring, Log Inspection, Application Control, Interfaces, Settings, Updates, and Overrides.

Top Navigation Bar: Shows 'Computer: [hostname]' and tabs for 'General', 'Actions', and 'System Events'.

Main Content Area:

- General Tab:** Contains fields for Hostname, Display Name, Description, Platform (Microsoft Windows Server 2012 (64 bit) Build 9200), Group (Computers), Policy (None), Asset Importance (None), and Download Security Updates From (Default Relay Group). Each dropdown menu has an 'Edit' button.
- Agent Status:** A red shield icon with a plus sign indicates the agent is 'Managed (Online)'. Below this, a list of modules shows their status: Anti-Malware (On, Real Time), Web Reputation (On, Real Time), Firewall (Off, not installed), Intrusion Prevention (Not Licensed), Integrity Monitoring (Not Licensed), Log Inspection (Not Licensed), and Application Control (Not Licensed).
- Scanner(SAP):** A blue magnifying glass icon indicates the scanner is 'On'.
- Online Status:** A green dot indicates the agent is 'Online'.
- Last Communication:** February 10, 2017 14:26.

Configure SAP to use the agent

The Deep Security Agent is now up and running and is able to scan the file system of its operating system. Next, we need to make the agent aware of the SAP application server. To use this, we must create a virus scan adapter inside the application server. The virus scan adapter must be part of a group. After the virus scan adapter and virus scan group are created, we can use virus scan profiles to configure what to scan and how to behave.

These are the required steps:

1. ["Configure the Trend Micro scanner group" on the next page](#)
2. ["Configure the Trend Micro virus scan provider" on page 1868](#)
3. ["Configure the Trend Micro virus scan profile" on page 1874](#)
4. ["Test the virus scan interface" on page 1884](#)

Note: The virus scan group and the virus scan adapter are both global configurations (client 00). The virus scan profile must be configured in each tenant (client 01, 02, etc.).

Configure the Trend Micro scanner group

Trend Micro Deep Security On-Premise 20

1. In the SAP WinGUI, run the **VSCANGROUP** transaction. In Edit mode, select **New Entries**.

2. Create a new scanner group, specifying a group name in the **Scanner Group** area and a description of the scanner group in the **Group Text** area.

3. Click the Save icon or leave the edit mode.

A dialog box named "Prompt for Workbench request" will appear. In the example shown below, a new workbench request is created to keep track of all the VSI-related changes:

Prompt for Workbench request	
View Cluster Maintena...	VSCAN_GROUP_VC
Request	NPLK900006 Workbench request
Short Description	VSI Integration TM

✓ ↻ ⚙ Own Requests ✖

The next step is the actual configuration of the VSI integration. It is called a **Virus Scan Adapter**.

Configure the Trend Micro virus scan provider

Trend Micro Deep Security On-Premise 20

1. In the SAP WinGUI, run the **VSCAN** transaction. In Edit mode, select **New Entries**.

2. Enter a new configuration of the VSI-certified solution.

In the example below, the following configuration parameters are set:

The screenshot shows the SAP configuration interface for a Virus Scan Adapter. The window title is "New Entries: Details of Added Entries". The configuration includes:

- Provider Type:** ADAPTER (Virus Scan Adapter)
- Provider Name:** VSA_SU15-NW75
- Status:** Start/Stop buttons
- Virus Scan Provider Definition:**
 - Scanner Group:** Z_TMGROUP
 - Status:** Active (Application Server)
 - Server:** SU15-NW75_NPL_00
 - Reinit. Interv.:** 8 Hours
 - Adapter Path:** /lib64/libsapvsa.so

Setting	Value	Description
Provider	ADAPTER (Virus Scan Adapter)	Automatically set (default)

Setting	Value	Description
Type		
Provider Name	VSA_<host name>	Automatically set, serves as alias
Scanner Group	Select the group that you configured earlier	All previously created scanner groups, which you can display using the input help
Status	Active (Application Server)	Automatically set (default)
Server	nplhost_NPL_42	Automatically set, hostname
Reinit. Interv.	8 Hours	Specifies the number of hours after which the Virus Scan Adapter will be reinitialized and load new virus definitions.
Adapter Path (Linux)	/lib64/libsapvsa.so	Default path
Adapter Path (Windows)	C:\Program Files\Trend Micro\Deep Security Agent\lib\dsvsa.dll	Default path

3. Click the Save icon or leave the edit mode.
A prompt to pack this into a workbench request appears.
4. Confirm the request, then click the **Start** button.
The Status light turns green, which means the adapter is loaded and active:

Table View Edit Goto Selection Utilities System Help

< **SAP** New Entries: Details of Added Entries

✓ [Dropdown] [Save] [Edit] [Refresh] [Cancel] [Print] [Fullscreen] [Refresh] [Settings] Exit

Provider Type: ADAPTER (Virus Scan Adapter) [Dropdown]

Provider Name: VSA_SU15-NW75

Status: ■

[Start] [Stop]

Virus Scan Provider Definition

Scanner Group: Z_TMGROUP [Search] [Display]

Status: Active (Application Server) [Dropdown]

Server: SU15-NW75_NPL_00

Trace Level: Errors Only [Dropdown]

Reinit. Interv.: 8 Hours Last Initialization: 22.06.2022 03:33:05 [Load]

Adapter Path: /lib64/libsapvsa.so

Configuration: [Empty Field]

Engine Data

Version	12.5
Version Text	VSAPI-12.5.1004
Date	Wed Jun 22 01:33:04 2022
Known Viruses	

Loaded Drivers

...
-----	-----	-----	-----

At this point, the VSI configuration is nearly finished. The application server is now ready to process file transactions using a virus scan provided by Trend Micro Deep Security.

Configure the Trend Micro virus scan profile

1. In the SAP WinGUI, run the **VSCANPROFILE** transaction, then select the SAP operation that requires virus scan.
For example, check the "Active" checkbox for **/SCET/GUI_UPLOAD** or **/SCET/GUI_DOWNLOAD** and then select **Save**.

Table View Edit Goto Selection Utilities System Help

< **SAP** Display View "Virus Scan Profile": Overview

✓ VSCANPROFILE

Cancel More

Exit

Dialog Structure

- Virus Scan Profile
 - Steps
 - Step Configuration P
 - Profile Configuration Pa
 - MIME Types

Virus Scan Profile

Virus Scan Profile	Active	Default Pr...	Profile Text
<input type="checkbox"/> /IWBEP/V4/ODATA_UPL...	<input type="checkbox"/>	<input type="checkbox"/>	
<input type="checkbox"/> /SAPC_RUNTIME/APC_W...	<input type="checkbox"/>	<input type="checkbox"/>	
<input type="checkbox"/> /SAPC_RUNTIME/APC_W...	<input type="checkbox"/>	<input type="checkbox"/>	
<input type="checkbox"/> /SARC/ARCHIVING_ADK	<input type="checkbox"/>	<input type="checkbox"/>	Virus Protection Using the Archive De
<input type="checkbox"/> /SBCOMS/SMTP_INBOUND	<input type="checkbox"/>	<input type="checkbox"/>	SMTP Inbox Processing
<input type="checkbox"/> /SCET/DP_VS_ENABLED	<input type="checkbox"/>	<input type="checkbox"/>	
<input type="checkbox"/> /SCET/GUI_DOWNLOAD	<input type="checkbox"/>	<input type="checkbox"/>	
<input type="checkbox"/> /SCET/GUI_UPLOAD	<input type="checkbox"/>	<input type="checkbox"/>	File Upload Using CL_GUI_FRONTEN
<input type="checkbox"/> /SCMS/KPRO_CREATE	<input type="checkbox"/>	<input type="checkbox"/>	
<input type="checkbox"/> /SCMS/KPRO_XML_CREA...	<input type="checkbox"/>	<input type="checkbox"/>	
<input type="checkbox"/> /SIHTTP/HTTP_DOWNLO...	<input type="checkbox"/>	<input type="checkbox"/>	
<input type="checkbox"/> /SIHTTP/HTTP_UPLOAD	<input type="checkbox"/>	<input type="checkbox"/>	File Upload Using the Method CL_HT
<input type="checkbox"/> /SIWB/KW_UPLOAD_CRE...	<input type="checkbox"/>	<input type="checkbox"/>	Create Versions/Objects in SAP Know
<input type="checkbox"/> /SMIM_API/PUT	<input type="checkbox"/>	<input type="checkbox"/>	MIME Repository
<input type="checkbox"/> /SOAP_CORE/WS_RECEI...	<input type="checkbox"/>	<input type="checkbox"/>	Receive SOAP messages using CL_S
<input type="checkbox"/> /SOAP_CORE/WS_SEND	<input type="checkbox"/>	<input type="checkbox"/>	Send SOAP messages using CL_SOA
<input type="checkbox"/> /SOM_FORM/DOCUMENT	<input type="checkbox"/>	<input type="checkbox"/>	
<input type="checkbox"/> /SRM/RCM_CREATE	<input type="checkbox"/>	<input type="checkbox"/>	
<input type="checkbox"/> /STC_CONT_API/API_L...	<input type="checkbox"/>	<input type="checkbox"/>	
<input type="checkbox"/> /SXMSF/PI_MESSAGING	<input type="checkbox"/>	<input type="checkbox"/>	

2. In Edit mode, select **New Entries**.

The virus scan profiles will define how specific transactions (file uploads, file downloads, etc.) are handled corresponding to the virus scan interface. To use the previously configured virus scan adapter in the application server, you need to create a new virus scan profile:

3. In the **Scan Profile** box, enter "Z_TMPProfile" and select the **Active**, **Default Profile**, and **Evaluate Profile Configuration Param** check boxes.

The screenshot shows the SAP GUI interface for configuring a Virus Scan Profile. The main window title is "New Entries: Details of Added Entries". The top menu bar includes "Table View", "Edit", "Goto", "Selection", "Utilities", "System", and "Help". The SAP logo is visible in the top left corner. Below the menu bar is a toolbar with a green checkmark, a dropdown menu, a save icon, a pencil icon, a minus icon, a left arrow icon, a right arrow icon, a "Cancel" button, a print icon, a refresh icon, a settings icon, and an "Exit" button.

The left sidebar shows the "Dialog Structure" with the following items:

- ✓ Virus Scan Profile (selected)
- Steps
 - Step Configuration P
- Profile Configuration Pa
- MIME Types

The main configuration area is titled "Virus Scan Profile" and contains the following fields and options:

- Scan Profile:
- Profile Text:
- Active:
- Evaluate Profile Configuration Param.:
- Default Profile:
- Use Reference:
- Link:

4. While still in edit mode, double-click the **Steps** folder to configure the steps:

5. Click **New Entries**.

The steps define what to do when the profile is called by a transaction.

6. Set the **Position** to "0", **Type** to "Group" and the **Scanner Group** to the name of the group that you configured earlier.

7. Click the Save icon or leave the edit mode.

A notification will (eventually) appear about an existing virus scan profile, **/SCET/DP_VS_ENABLED**.

8. Ignore the notification about an existing profile because the profile is not active and is not used.

After confirming this notification, you will be asked to pack this configuration in a "customization request". Creating a new request will help keep track of the changes that have been made:

9. To create configuration parameters for a step, double-click the **Profile Configuration Parameters** folder, then click **New Entries** and set the parameters:

Parameter	Type	Description
CUST_ACTIVE_CONTENT	BOOL	Check if a file contains script (JavaScript, PHP, or ASP script) and block.

Parameter	Type	Description
CUST_CHECK_MIME_TYPE	BOOL	<p>Check if the file extension name matches its MIME type. If they do not match, the file is blocked. All MIME types and extension names can be exactly matched. For example:</p> <ul style="list-style-type: none"> • Word files must be .doc or .dot • JPEG files must be .jpg • Text and binary files can have any extension (no block) <p>See Supported MIME types.</p>

10. Double-click the **Step Configuration Parameters** folder. Select **New Entries** and set the parameters:

Parameter	Type	Description	Default (Linux)	Default (Windows)
SCANBESTEFFORT	BOOL	The scan should be performed on the best effort basis; that is, all security critical flags that allow a VSA to scan an object should be activated, such as SCANALLFILES and SCANEXTRACT, but also internal flags. Details about exactly which flags these are can be stored in the certification.	(not set)	(not set)
SCANALLFILES	BOOL	Scans for all files regardless of their file extension.	disabled	disabled
SCANEXTENSIONS	CHAR	List of the file extensions for which the VSA should scan. Only files with the configured extensions are checked. Other extensions are blocked. Wildcards can also be used here to search for patterns. * stands for this location and following and ? stands for only this character. For example, exe;com;do?;ht* => *\` means to scan all files.	null	""

Parameter	Type	Description	Default (Linux)	Default (Windows)
SCANLIMIT	INT	This setting applies to compressed files. It specifies the maximum number of files that are unpacked and scanned.	INT_MAX	65535
SCANEXTRACT	BOOL	Archives or compressed objects are to be unpacked	enabled	enabled
SCANEXTRACT_SIZE	SIZE_T	Maximum unpack size	0x7FFFFFFF	62914560 (60 MB)
SCANEXTRACT_DEPTH	INT	Maximum depth to which an object is to be unpacked.	20	20
SCANLOGPATH	CHAR	Custom log path for VSA.	(not set)	(not set)
SCANMIMETYPES	CHAR	List of the MIME types to be scanned for. Only files with configured MIME types are checked. Other MIME types are blocked. This parameter works only if CUST_CHECK_MIME_TYPE is enabled.	(not set)	(not set)
BLOCKMIMETYPES	CHAR	List of MIME types that are blocked. This parameter works only if CUST_CHECK_MIME_TYPE is enabled.	(not set)	(not set)
BLOCKEXTENSIONS	CHAR	List of file extensions that are blocked.	(not set)	(not set)

This configuration is per-client, so it must be done in each tenant of the SAP application server.

Test the virus scan interface

Trend Micro Deep Security On-Premise 20

1. In the SAP WinGUI, run the **VSCANTEST** transaction.

Program Edit Goto System Help

SAP Test for Virus Scan Interface

VSCANTEST Cancel

Object to Be Checked

Test Data
EICAR Anti-Virus Test File

Local File

File on Application Server

Scanner Selection

Virus Scan Profile
(Defaultprofil)

Scanner Group

Virus Scan Provider

General Settings

Display Scan Details

Action Check Only

Trend Micro Deep Security On-Premise 20

Every VSI-aware SAP application server also has a built-in test to check whether the configuration steps were done correctly. For this, an EICAR test virus (www.eicar.org) is packed in a transaction that can call a specific scanner.

2. Not filling in anything will call the default profile, which was configured in the last step, so do not fill in anything.
3. Click Execute.

A notification appears that explains what an EICAR test virus is.

Trend Micro Deep Security On-Premise 20

4. Confirm the notification.

The transaction is intercepted:

Navigation: Goto System Help

SAP

Result

✘ Return Value: 2- (At least one virus found)

Infections

ID	Virus Name	Object
	Eicar_test_1	/tmp/qqaooiZ_TMPROFILE

Content Information

File Name Extension	MIME Type	Object
	text/plain	/tmp/qqaooiZ_TMPROFILE

Summary: 0 errors, 1 warning, 0 info, 5 success

Ty...	Message Text	LTxt
■	Start the processing of virus scan profile Z_TMPROFILE	
■	Virus scan profile Z_TMPROFILE, step 00: scanner group Z_TMGROUP	
■	Virus scan adapter VSA_SU15-NW75 was selected from scanner group Z_TMGROUP	
■	Virus scan profile Z_TMPROFILE, step 00: scan instance returns 2- (At least one virus found)	
●	Virus "Eicar_test_1" found in object "/tmp/qqaooiZ_TMPROFILE"	?
■	Profile Z_TMPROFILE failed, since step 00 failed (AND linkage)	

Infections shows information about the detected malware.

Content Information shows the correct MIME-type of the file.

The file name is always a randomly generated 7-letter alphabetic string followed by the virus scan profile name.

After this, there is an output about each step of the transaction:

1. The transaction called the default virus scan profile, which is the virus scan profile Z_TMPROFILE.
2. The virus scan profile Z_TMPROFILE is configured to call an adapter from the virus scan group Z_TMGROUP.
3. The virus scan group Z_TMGROUP has multiple adapters configured and calls one of them (in this case, VSA_NPLHOST).
4. The virus scan adapter returns value 2-, which means a virus was found.
5. Information about the detected malware is displayed by showing Eicar_test_1 and the file object /tmp/ zUeEbZZ_TMPROFILE.
6. The called default virus scan profile Z_TMPROFILE fails because step 00 (the virus scan group) was not successful and therefore the file transaction is stopped from further processing.

For a cross-check, there is also information about this "malware" event in the Deep Security Manager console. To see the event, open the **Computer editor**¹ and select **Anti-Malware > Events**.

Supported MIME types

The MIME types supported by Deep Security Scanner vary depending on which version of the Deep Security Agent you are using.

- Deep Security Agent 9.6 uses VSAPI 9.85
- Deep Security Agent 10.0 uses ATSE 9.861
- Deep Security Agent 10.1 uses ATSE 9.862

¹To open the Computer editor, go to the Computers page and double-click the computer that you want to edit (or select the computer and click Details).

Trend Micro Deep Security On-Premise 20

- Deep Security Agent 10.2, 10.3, 11.0, 11.1, and 11.2 uses ATSE 10.000
- Deep Security Agent 11.3 and higher uses ATSE 11.0.000

MIME Type	Description	Extension	Supported in 9.6 Agent	Supported in 10.0 Agent	Supported in 10.1 Agent or higher
application/octet-stream		*	Yes	Yes	Yes
application/com	COM File	com	Yes	Yes	Yes
application/ecmascript	EMCScript File	es	Yes	Yes	Yes
application/hta	HTA File	hta	Yes	Yes	Yes
application/java-archive	Java Archive (JAR) file	jar	Yes	Yes	Yes
application/javascript	Javascript File	js, jsxinc, jsx	Yes	Yes	Yes
application/msword	Word for Windows	doc, dot	Yes	Yes	Yes
application/vnd.ms-access	MS Access	mdb	No	No	No
application/vnd.ms-project	MS Project	mpp	No	No	No
application/msword	MS Word	doc, dot	Yes	Yes	Yes
application/octet-stream	COM File	com	Yes	Yes	Yes
application/octet-stream	EXE File	exe	Yes	Yes	Yes
application/pdf	Adobe Portable Document Format file	pdf	Yes	Yes	Yes
application/postscript	Postscript	ai	Yes	Yes	Yes
application/postscript	Postscript	ps	Yes	Yes	Yes
application/postscript	Postscript	ps	Yes	Yes	Yes
application/rar	RAR File	rar	Yes	Yes	Yes
application/rtf	Microsoft RTF	rtf	Yes	Yes	Yes
application/sar	Sar File	sar	Yes	Yes	Yes
application/vnd.ms-excel	Excel for Windows	xls, xlt, xla	Yes	Yes	Yes
application/vnd.ms-outlook	Outlook for Windows	msg	No	Yes	Yes
application/vnd.ms-powerpoint	Windows PowerPoint	ppt, pot, pps, ppa	Yes	Yes	Yes
application/vnd.ms-publisher	MS Publisher	pub	No	No	Yes
application/vnd.oasis.opendocument	Open Document	odf	Yes	Yes	Yes
application/vnd.openxmlformats-officedocument.presentationml.presentation	MS Office File	pptx, potx, ppsx, ppam, pptm, potm, ppsm	Yes	Yes	Yes

Trend Micro Deep Security On-Premise 20

MIME Type	Description	Extension	Supported in 9.6 Agent	Supported in 10.0 Agent	Supported in 10.1 Agent or higher
application/vnd.openxmlformats-officedocument.spreadsheetml.sheet	MS Office File	xlsx, xltx, xlsx, xltm, xlam, xlsb	Yes	Yes	Yes
application/vnd.openxmlformats-officedocument.wordprocessingml.document	MS Office File	docx, dotx, docm, dotm	Yes	Yes	Yes
application/vnd.rn-realmedia	Real Media	rm	Yes	Yes	Yes
application/wordperfect	WOrdPerfect	wp, wp5, wp6, wpd, w60, w61	Yes	Yes	Yes
application/x-alf		alf	Yes	Yes	Yes
application/x-arc-compressed	ARC File	arc	Yes	Yes	Yes
application/x-bzip2	bZIP File	*	Yes	Yes	Yes
application/x-cpio	CPIO File	*	Yes	Yes	Yes
application/x-director	Macromedia Director Shockwave Movie	dcr	Yes	Yes	Yes
application/x-gzip	Gzip	*	Yes	Yes	Yes
application/xhtml+xml	XHTML	dhtm, dhtml, htm, html, htx, sht, shtm, shtml, stml, xht, xhtm, xhtml, xml, txt	Yes	Yes	Yes
application/x-java-class	JAVA Applet	class	Yes	Yes	Yes
application/x-kep		kep	Yes	Yes	Yes
application/x-otf		otf	Yes	Yes	Yes
application/x-sapshortcut		sap, sapc	Yes	Yes	Yes
application/x-shockwave-flash	Macromedia Flash	swf	Yes	Yes	Yes
application/x-silverlight-app	PKZIP	xap	Yes	Yes	Yes
application/x-sim		sim	Yes	Yes	Yes
application/x-tar	TAR File	tar	Yes	Yes	Yes
application/x-vbs		*	Yes	Yes	Yes
application/zip	ZIP File	zip, zipx	Yes	Yes	Yes
audio/basic	Audio	snd, au	Yes	Yes	Yes
audio/midi	MIDI	mid, midi, rmi, mdi, kar	Yes	Yes	Yes
audio/x-aiff	Audio InterChange File Format from Apple/SGI	aiff, aif, aifc	Yes	Yes	Yes
audio/x-mpeg-3	MP3	mp3	Yes	Yes	Yes
audio/x-realaudio	Real Audio	ra	Yes	Yes	Yes

Trend Micro Deep Security On-Premise 20

MIME Type	Description	Extension	Supported in 9.6 Agent	Supported in 10.0 Agent	Supported in 10.1 Agent or higher
audio/x-voc	Creative Voice Format (VOC)	voc	Yes	Yes	Yes
image/bmp	Windows BMP	bmp	Yes	Yes	Yes
image/gif	GIF	gif	Yes	Yes	Yes
image/ico	Windows Icon	ico	Yes	Yes	Yes
image/jpeg	JPEG	jpg, jpeg, jpe, jif, jfif, jfi	Yes	Yes	Yes
image/msp	Microsoft Paint	msp	Yes	Yes	Yes
image/png	Portable Network Graphics	png	Yes	Yes	Yes
image/ppm	PPM image	ppm	Yes	Yes	Yes
image/svg+xml		svg	Yes	Yes	Yes
image/tiff	TIFF	tif, tiff	Yes	Yes	Yes
image/vnd.ms-modi	Microsoft Document Imaging	mdi	Yes	Yes	Yes
image/x-cpt	Corel PhotoPaint	cpt	Yes	Yes	Yes
image/x-pcx	PCX	pcx	Yes	Yes	Yes
image/x-pict	Macintosh Bitmap	pct	Yes	Yes	Yes
image/x-ras	Sun Raster(RAS)	ras	Yes	Yes	Yes
image/x-wmf	Windows Metafile	wmf	Yes	Yes	Yes
text/csv	CSV	csv, txt	Yes	Yes	Yes
text/html	HTML	dhtm, dhtml, htm, html, htx, sht, shtm, shtml, stml, xht, xhtm, xhtml, xml, txt	Yes	Yes	Yes
text/plain		*	Yes	Yes	Yes
text/plain	Text File	txt	Yes	Yes	Yes
text/xml	XML	dhtm, dhtml, htm, html, htx, sht, shtm, shtml, stml, xht, xhtm, xhtml, xml, txt	Yes	Yes	Yes
text/xsl	XSL	xsl	Yes	Yes	Yes
unknown/unknown		*	Yes	Yes	Yes
video/mpeg		*	Yes	Yes	Yes
video/quicktime	Quick Time Media	qt	Yes	Yes	Yes
video/x-fli	AutoDesk Animator	fli	Yes	Yes	Yes
video/x-flv	Macromedia Flash FLV	flv	Yes	Yes	Yes

MIME Type	Description	Extension	Supported in 9.6 Agent	Supported in 10.0 Agent	Supported in 10.1 Agent or higher
	Video				
video/x-ms-asf	Advanced Streaming Format	asf	Yes	Yes	Yes
video/x-scm	Lotus ScreenCam Movie	scm	Yes	Yes	Yes

Integrate with Smart Protection Server

If you have Deep Security Agents in AWS, and you want them to be able to access Trend Micro's Smart Protection Network, then you must allow them to connect to the Internet on port 80 (HTTP) or 443 (HTTPS). (See ["Port numbers, URLs, and IP addresses" on page 410](#).) If this is not possible, you can deploy your own Smart Protection Server (SPS) within your Virtual Private Network (VPC) in AWS, or another VPC. The Smart Protection Server connects outbound to the Smart Protection Network to retrieve the latest anti-malware, file reputation, and web reputation information and then passes this information along to your agents.

To deploy a Smart Protection Server in AWS, you can either:

- use an AWS CloudFormation template created by Trend Micro . This is the easiest way to deploy the server because the configuration is automated.
- install it manually. See the [Smart Protection Server documentation](#) for details.

The instructions below describe how to deploy the Smart Protection Server using the CloudFormation template.

1. In AWS, at the top, click **Services** and search for the **CloudFormation** service.
2. On the **CloudFormation** service page, click **Create Stack**.

The **Select Template** page appears.

Select Template

Select the template that describes the stack that you want to create. A stack is a group of related resources that you manage as a single unit.

Design a template Use AWS CloudFormation Designer to create or modify an existing template. [Learn more.](#)

Choose a template A template is a JSON/YAML-formatted text file that describes your stack's resources and their properties. [Learn more.](#)

Select a sample template

Upload a template to Amazon S3
 No file chosen

Specify an Amazon S3 template URL
 [View/Edit template in Designer](#)

3. Select **Specify an Amazon S3 template URL** and enter this URL into the underlying field:

`https://s3.amazonaws.com/trend-micro-quick-start/latest/templates/common/sps.template`

4. Click **Next**.

Finish entering settings in the template. Choose the AWS key pairs you would like to use to authenticate to the server, the VPC and subnet where the Smart Protection Server will reside, and an administrator password. The password cannot contain special characters such as: !@#\$%^&*()

Warning: Do not enter a password that contains dictionary words. It should be at least 8 characters in length. Failure to do this will result in a weak password that is vulnerable to guessing and brute force attacks, and could compromise the security of your network.

Specify Details

Specify a stack name and parameter values. You can use or change the default parameter values, which are defined in the AWS CloudFormation template. [Learn more.](#)

Stack name

Parameters

AWSKeyPairName Existing key pair to use for connecting to your Smart Protection Server

AWSVPC Existing VPC to deploy Smart Protection Server

AWSSubnetID Existing Subnet for Smart Protection Server. Must be a subnet contained the in VPC chosen above.

SPSInstanceType Amazon EC2 instance type for the Smart Protection Server

SPSWebAdminPassword The Smart Protection Server admin account password

5. Click **Next**.

6. Optionally, create any tags that you would like to associate with this server, then click **Next**.

The screenshot shows a configuration window titled "Options". Under the "Tags" section, there is a table for adding key-value pairs. The table has two columns: "Key (127 characters maximum)" and "Value (255 characters maximum)". A single row is present with the value "MK" in both columns. To the right of the table is a blue "+" button. Below the table is an "Advanced" section with a right-pointing arrow and a "Learn more" link. At the bottom right of the window are three buttons: "Cancel", "Previous", and "Next".

	Key (127 characters maximum)	Value (255 characters maximum)	
1	MK	MK	+

7. Review your settings, and then click **Create**.

Review

Template

Template URL	https://s3.amazonaws.com/trend-micro-quick-start/latest/templates/common/spc.template
Description	
Estimate cost	Link is not available

Stack details

Stack name	SPS
AWSKeyPairName	MKs-Key
AWSVPC	vpc-7273dc17
AWSSubnetID	subnet-e68f0e83
SPSInstanceType	t2.medium
SPSWebAdminPassword
Create IAM resources	No

Options

Tags

MK	MK
----	----

Advanced

Notification	
Timeout	none
Rollback on failure	Yes

While your server is being installed, the screen will indicate progress. To verify that the process has completed, you may need to click **Refresh** at the top of the screen.

Trend Micro Deep Security On-Premise 20

Filter: Active ▾ SPS <input type="text"/> ✕				
	Stack Name	Created Time	Status	Description
<input type="checkbox"/>	SPS	2018-05-08 11:31:39 UTC+0800	CREATE_IN_PROGRESS	v5.12: Smart protection server template (qs-1ngr590jj).

Filter: Active ▾ SPS ✕

	Stack Name	Created Time	Status	Description
<input checked="" type="checkbox"/>	SPS	2018-05-08 11:31:39 UTC+0800	CREATE_COMPLETE	v5.12: Smart protection server template (qs-1ngr590jj).

Overview Outputs Resources Events Template Parameters Tags Stack Policy Change Sets Rollback Triggers

Key	Value	Description
FRSurl	https://172.16.20.134:443/tmcSS	
WRSurl	http://172.16.20.134:5274	
WRSHTTPSurl	https://172.16.20.134:5275	

8. After it is done creating, click the **Outputs** tab at the bottom of the screen. You see three URLs. In the Deep Security Manager's GUI, you must configure your computers to use the Smart Protection Server.
9. Log in to Deep Security Manager.
10. At either the policy level (recommended method) or at the computer level, go to the anti-malware section.
11. Click the Smart Protection tab at the top. Toward the bottom of the screen, deselect **Inherited** under **Smart Protection Server for File Reputation Service**.

12. Select **Use locally installed Smart Protection Server**.
13. Enter in the URL from the **Outputs** screen in your AWS console labeled "FRSurl" and click **Add**.
14. Click **Save**.
15. Open the web reputation section of the policy or computer and click the **Smart Protection** tab at the top.
16. Deselect **Inherited** under **Smart Protection Server for Web Reputation Service**.
17. Select **Use locally installed Smart Protection Server**.
18. Add the URL from the **Outputs** screen in your AWS console labeled "WRSurl" or "WRSHTTPSurl" and click **Add**. You can use the HTTP or HTTPS URL, but HTTPS is only supported with 11.0 Deep Security Agents and up.
19. Click **Save**.
20. If you don't have your system set up to automatically send policies, you will need to manually send the policy from your Deep Security Manager.

Integrate with Trend Micro Vision One

Integrate with Trend Micro Vision One (XDR)

The XDR capabilities of Trend Micro Vision One applies effective expert analytics and global threat intelligence using data collected across multiple vectors - email, endpoints, servers, cloud workloads, and networks.

Note: Personally identifiable information is collected by Trend Micro Vision One. For more information about what information is collected, see [Trend Micro XDR Data Collection Notice](#).

There is currently one way to integrate Trend Micro Vision One with Deep Security:

- Purchase a license. For information, see "[Register with Trend Micro Vision One \(XDR\)](#)" on the next page.

After successfully registering with Trend Micro Vision One (XDR), [security events for protection modules](#) are forwarded to Trend Micro Vision One by default. To [forward activity data](#) to Trend Micro Vision One, you need to install Trend Micro Endpoint Basecamp with the [relevant deployment script](#) or an [installer downloaded from the Trend Micro Vision One console](#).

Register with Trend Micro Vision One (XDR)

1. Obtain the Trend Micro Vision One enrollment token from your organization's administrator.

Your organization's administrator can follow the steps [here](#) to obtain the token.

Note: The token is only valid for 24 hours after it's generated. If it expires, generate a new one using the same steps.

2. In Deep Security Manager, go to **Administration > System Settings > Trend Micro Vision One**.
3. Click **Register enrollment token**.
4. In the pop-up window, paste the enrollment token you received from your organization's administrator and click **Register**.

After registration has completed successfully, Deep Security automatically forwards data to the Trend Micro Vision One platform, where it is analyzed.

Forward security events to Trend Micro Vision One (XDR)

After successfully registering to Trend Micro Vision One (XDR), the **Forward security events to Trend Micro Vision One** setting is enabled by default. When this configuration is enabled, events from the following protection modules are forwarded to Trend Micro Vision One:

- Anti-Malware
- Web Reputation
- Device Control
- Integrity Monitoring

Trend Micro Deep Security On-Premise 20

- Log Inspection
- Intrusion Prevention

If you'd like to stop forwarding security events to Trend Micro Vision One, go to **Administration > System Settings > Trend Micro Vision One** and deselect the **Forward security events to Trend Micro Vision One** option.

If you have connected your agents and relays to the 'primary security update source' via a proxy, the same proxy settings will automatically be used.

Forward activity data to Trend Micro Vision One (XDR)

To forward activity data to Trend Micro Vision One, you need to install Trend Micro Endpoint Basecamp with the [relevant deployment script](#) or an [installer downloaded from the Trend Micro Vision One console](#).

The deployment script can be deployed with tools like RightScale, Chef, Puppet, or SSH as an administrator.

Note: Before you generate the deployment script, check the system requirements and supported operating systems on [XDR Sensor System Requirements](#) and be aware of the [prerequisite verification](#) executed on the script.

Generate a deployment script

1. Before you begin, ensure Deep Security Manager is connected to Trend Micro Vision One.
2. Go to **Administration > System Settings > Trend Micro Vision One**.
3. Under **Activity Data Forwarding**, select your platform. The deployment script generator displays the relevant script.
4. Click **Copy to Clipboard** and paste the deployment script in your preferred deployment tool, or click **Save to File**.

Note: The deployment scripts generated by Deep Security Manager for Windows requires Windows PowerShell version 4.0 or later. You must run PowerShell as an administrator. If the script is not running, enter the following command:

```
Set-ExecutionPolicy RemoteSigned
```

If you need to deploy an agent to a version of Windows or Linux that doesn't include PowerShell 4.0 or curl 7.34.0:

- Linux: remove the `--tls1.2` tag.

```
- Windows: remove the [Net.ServicePointManager]::SecurityProtocol =  
[Net.SecurityProtocolType]::Tls12; line.
```

Removing the above lines allows an earlier version of TLS (version 1.0) to communicate with the manager. Ensure that an earlier TLS is also allowed on the manager and relays. See ["Determine whether TLS 1.2 is enforced" on page 1837](#) and ["Enable early TLS \(1.0\)" on page 1835](#) for details.

5. Modify the script to add the proxy server address if a proxy is required.

Once Trend Micro Endpoint Basecamp is installed, enable the sensor on Trend Micro Vision One Endpoint Inventory.

Note: Endpoint Basecamp does not support proxy credentials.

Download the agent installer

To download the agent installer, go to **Trend Micro Vision One > Endpoint Inventory** and follow the instructions to check the prerequisite verification for agents.

Integrate with Trend Vision One Service Gateway

Supported Service Gateway version

Deep Security supports Service Gateway version 1.0 and 2.0.

Set up a scheduled report

For information on the system requirements for the Service Gateway, see [Service Gateway Appliance System Requirements](#).

Deploy Service Gateway

For information on deploying the Service Gateway in your network, see [Deployment Guides](#).

FAQs

Why does my Windows machine lose network connectivity when I turn on protection?

A Windows machine will lose connectivity for a brief period of time during the network driver installation while the Deep Security Agent installs a network driver to examine traffic. This only happens the *first* time a policy is applied that includes one of the following:

- Web reputation
- Firewall
- Intrusion prevention

A Windows machine uses the same driver is used for all three protection modules listed above. Turning on web reputation, firewall or intrusion prevention after one of those features already turned on will not cause another network blip. You may see a similar interruption in network connectivity when the agent is upgraded (as the driver may also need to be upgraded).

How do I get news about Deep Security?

The Deep Security news feed has been discontinued. Instead, you can find the latest news on product changes in the ["What's new?" on page 122](#) article.

Trend Micro continue to release new rule updates every Tuesday, with additional updates as new threats are discovered. Details about each rule update are provided in the [Trend Micro Threat Encyclopedia](#).

How does agent protection work for Solaris zones?

The Deep Security Agent can be deployed only on a Solaris global zone. If your Solaris environment uses any non-global zones, the protection that the agent can provide for the global zone and non-global zones will differ with each protection module:

- [Intrusion Prevention](#)
- [Firewall](#)
- [Web Reputation](#)
- [Anti-Malware](#)
- [Integrity Monitoring](#)
- [Log Inspection](#)

See ["Install the agent manually" on page 515](#) for more on installing the Deep Security Agent on Solaris.

Intrusion Prevention (IPS), Firewall, and Web Reputation

If your Solaris environment uses any non-global zones, the Intrusion Prevention, Firewall, and Web Reputation modules can only provide protection to specific traffic flows between the global zone, non-global zones and any external IP addresses. Which traffic

flows the agent can protect depends on if the non-global zones use a [shared-IP network interface](#) or an [exclusive-IP network interface](#).

Kernel zones use an [exclusive-IP network interface](#) and agent protection to traffic flows is limited to that network configuration.

Non-global zones use a shared-IP network interface

Agent protection to traffic flows in a shared-IP configuration is as follows:

Traffic Flow	Protected by agent
external address <-> non-global zone	Yes
external address <-> global zone	Yes
global zone <-> non-global zone	No
non-global zone <-> non-global zone	No

Non-global zones use an exclusive-IP network interface

Agent protection to traffic flows in a exclusive-IP configuration is as follows:

Traffic Flow	Protected by agent
external address <-> non-global zone	No
external address <-> global zone	Yes
global zone <-> non-global zone	Yes

Traffic Flow	Protected by agent
non-global zone <-> non-global zone	No

Anti-Malware, Integrity Monitoring, and Log Inspection

The Anti-Malware, Integrity Monitoring and Log Inspection modules provides protection to the global zone. For non-global zones, any files or directories that are also visible to the global zone are protected. Files specific to a non-global zone are not protected.

How do I protect AWS GovCloud (US) instances?

There are two ways that Deep Security provides [AWS GovCloud \(US\)](#) support:

- You can use the Trend Micro Deep Security AMI (Per Protected Instance Hour or BYOL license type) that is available from the AWS Marketplace for AWS GovCloud (US). The deployment instructions for the AWS GovCloud (US) region are the same as any other region. See [Getting started with Deep Security AMI from AWS Marketplace](#).
- You can install the enterprise version of the Deep Security software on an AWS instance running in the AWS GovCloud (US) region.

Protecting AWS GovCloud (US) instances using a manager in a commercial AWS instance

Warning: Be aware that if your Deep Security Manager is outside of the AWS GovCloud, using it to manage computers in the AWS GovCloud would break ITAR compliance.

If your Deep Security Manager is in a commercial AWS instance and you want to use it to protect AWS GovCloud instances, you cannot use the cloud connector provided in the Deep Security Manager console to add the instances. If Deep Security Manager is running in a special region (like AWS GovCloud), it can connect to that region and also connect to instances in commercial AWS regions. But if Deep Security Manager is in a commercial region, it can connect to all commercial AWS regions but not special regions like AWS GovCloud.

If you want to add a special region connector (like AWS GovCloud) into a Deep Security Manager running in commercial AWS, you will need to use the Deep Security legacy REST API to do so and supply the `seedRegion` argument to tell the Deep Security Manager that it's connecting outside of commercial AWS. For information about the API, see ["Use the Deep Security API to automate tasks" on page 1764](#).

How do I protect Azure Government instances?

To protect [Azure Government](#) instances, you have a few options:

- You can deploy Deep Security Manager using the Deep Security Manager (BYOL) VM that's listed inside Azure Government's Marketplace (see the image below). The deployment instructions for the Azure Government are the same as any other region.
- You can install the Deep Security Manager on-premises software onto an Azure VM running inside Azure Government.

Make sure you deploy from Azure Government, and use the Deep Security Manager (BYOL) VM

The screenshot shows the Microsoft Azure Government Marketplace interface. The breadcrumb navigation is 'Home > Marketplace > Everything'. The left sidebar contains navigation options: 'Create a resource', 'Home', 'Dashboard', 'All services', 'FAVORITES', 'All resources', 'Resource groups', 'App Services', 'Function Apps', and 'SQL databases'. The main content area is titled 'Marketplace' and 'Everything'. A search bar contains the text 'Deep Security Manager (BYOL)'. Below the search bar, there are filters for 'Pricing' (set to 'All') and 'Oper' (set to 'All'). The search results are displayed under the heading 'RESULTS' and include a table with the following entry:

NAME
 Deep Security Manager (BYOL)

Red annotations highlight the 'Microsoft Azure Government' header in the top left and the search result for 'Deep Security Manager (BYOL)' in the results table. A red line also points from the top text annotation to the search results area.

Protecting Azure Government instances using a manager in global Azure

Warning: Be aware that if your Deep Security Manager is outside of Azure Government, using it to manage computers in the Azure Government would break [ITAR compliance](#).

You cannot use the **Computers > Add > Add Account** option in the Deep Security Manager console to add Azure Government instances to a manager in global Azure, and vice versa. This is because the manager can only communicate with Azure instances in its own cloud.

If your Deep Security Manager is located outside the Azure Government cloud, and you want to use it to protect instances in the Azure Government cloud, you will need to use the Deep Security legacy REST API, and supply the `azureADLoginEndPoint` and `azureEntryPoint` arguments. For details on using the API, see [Create Cloud Account](#).

How does Deep Security Agent use the Amazon Instance Metadata Service?

When running on EC2 instances in AWS, the Deep Security Agent uses the Amazon Instance Metadata Service (IMDS) to query information about the EC2 instance.

Note: Deep Security support for IMDS v2 was added in Deep Security Manager FR 2020-04-29 and Deep Security Agent FR 2020-05-19. If you are using an older version of Deep Security only IMDS v1 is supported and you must ensure that your AWS configuration allows Deep Security Agent access to host metadata using IMDS v1.

The information retrieved by the Deep Security Agent is necessary to ensure that the agent activates under the proper AWS account within Deep Security.

If the Deep Security Agent cannot successfully retrieve data from the instance using a Metadata Service Version 1 (IMDSv1) or 2 (IMDSv2), the following issues might be encountered:

Issue	Root cause	Resolution	Additional notes
Duplicate computers appear - one under the AWS account and another outside of the AWS account.	If the Deep Security Agent does not have access to Instance Metadata Service Version 1 (IMDSv1) or 2 (IMDSv2), Deep Security cannot properly associate this activation with the desired cloud account.	Ensure that Deep Security has access to IMDS v1 or IMDS v2.	If you determine that the creation of duplicate computers has occurred, you can use inactive agent cleanup to automatically remove these computers.
Smart folders or event-based tasks based on AWS metadata fail.	If the Deep Security Agent does not have access to Instance Metadata Service Version 1 (IMDSv1) or 2 (IMDSv2), Deep Security cannot access the AWS metadata needed for these operations.	For more details, see Configuring the Instance Metadata Service .	N/A

How can I minimize heartbeat alerts for offline environments in an AWS Elastic Beanstalk environment?

AWS Elastic Beanstalk allows you to create multiple environments so that you can run different versions of an application at the same time. These environments usually include a production and development environment and often the development environment is powered down at night. When the development environment is brought back online in the morning, Deep Security will generate alerts related to communication problems for the period of time that it was offline. Although these alerts are actually false from your perspective, they are legitimate alerts from the perspective of Deep Security because an alert is generated whenever a specified number of heartbeats is missed.

You can minimize these heartbeat-related alerts or even prevent them from being generated for environments that you know will be offline for a period of time every day by creating a policy with specific heartbeat settings and applying that policy to the servers in those partially offline environments.

1. Go to the **Policies** tab in the main Deep Security Manager window.
2. Create a new policy or edit an existing one.
3. Click the **Settings** tab in the **Policy editor**¹ and go to the **Computer** tab.
4. Change one or both of the **Heartbeat Interval** and **Number of Heartbeats that can be missed before an alert is raised** setting to numbers that take into account the number of hours your Elastic Beanstalk environment will be offline.
For example, if you know that a server will be offline for 12 hours a day and the Heartbeat Interval is set at 10 minutes, you could change the Number of Heartbeats that can be missed before an alert is raised setting to unlimited to never get an alert or you could increase the Heartbeat Interval to something greater than 10 to get fewer alerts.
5. Click **Save** and apply the policy to all relevant servers.

For more information on using Deep Security in an AWS Elastic Beanstalk environment, you can watch the Trend Micro webinar [Deploying Scalable and Secure Web Apps with AWS Elastic Beanstalk and Deep Security](#).

Why can't I add my Azure server using the Azure cloud connector?

If an Azure server loses connectivity to the Azure metadata service, the Deep Security Manager will no longer be able to identify it as an Azure server and you will be unable to add it using the Azure cloud connector.

This situation can happen if the server's public or private IP address is changed outside of the Azure console. The Azure server relies on DHCP to communicate with the metadata service and changing the IP outside of the console disables DHCP.

Microsoft recommends against changing the Azure VM's IP address from within its operating system, unless necessary, such as when assigning multiple IP addresses to a Windows VM. For details, see [this Azure article](#).

¹To open the Policy editor, go to the Policies page and double-click the policy that you want to edit (or select the policy and click Details).

To check if your Azure server is able to connect to the Azure metadata service, run the [Detect Windows Azure Virtual Machine](#) PowerShell script from the Microsoft Script Center.

Why can't I view all of the VMs in an Azure subscription in Deep Security?

If not all of the virtual machine resources in an Azure subscription are being displayed on the Computers page of Deep Security Manager, this could be because they were deployed using the Azure deployment model Resource Manager. All resources are deployed using this model unless you select **Classic** from the **Select a deployment model** list.

Not all VMs are displayed because older versions of the Deep Security Manager use the [Service Management API](#) provided by the classic Azure deployment model (the Service Management model) to connect to Azure virtual machines so it can only enumerate VMs deployed with the Classic model.

To see both Classic or Resource Manager VMs, upgrade your cloud connector. For more information, see "[Why should I upgrade to the new Azure Resource Manager connection functionality?](#)" on page 668.

Note: If you are unable to upgrade your Resource Manager servers as per the article above, you can still protect them by using the deployment script on the VM and letting the activation create a new computer object outside of the connector.

Deep Security coverage of Log4j vulnerability

On December 9, 2021, a new critical zero-day vulnerability impacting multiple versions of the popular Apache Log4j 2 logging library was publicly disclosed. If exploited, this vulnerability could result in Remote Code Execution (RCE) by logging a certain string on affected installations. This specific vulnerability has been assigned CVE-2021-44228 and is also being commonly referred to as "Log4Shell" in various blogs and reports.

Deep Security includes the [Intrusion Prevention](#) module (IPS), which protects your computers from zero-day vulnerabilities and other attacks. Intrusion Prevention rules provide "virtual patching" by intercepting traffic that's trying to exploit the vulnerability, protecting your computers until vendor's patches that fix the vulnerability are released, tested, and deployed.

The Trend Micro Labs team has provided a new IPS rule to address this vulnerability:

1011242 - Apache Log4j Remote Code Execution Vulnerability (CVE-2021-44228)

Apply virtual patching for the Log4j vulnerability

Follow the steps below to check whether the new rule is protecting your computers.

1. In Deep Security Manager, go to **Administration > Updates > Security > Rules**.
2. The new rule is included in **21-057.dsr**. Check that the rule update is shown as **Applied**.

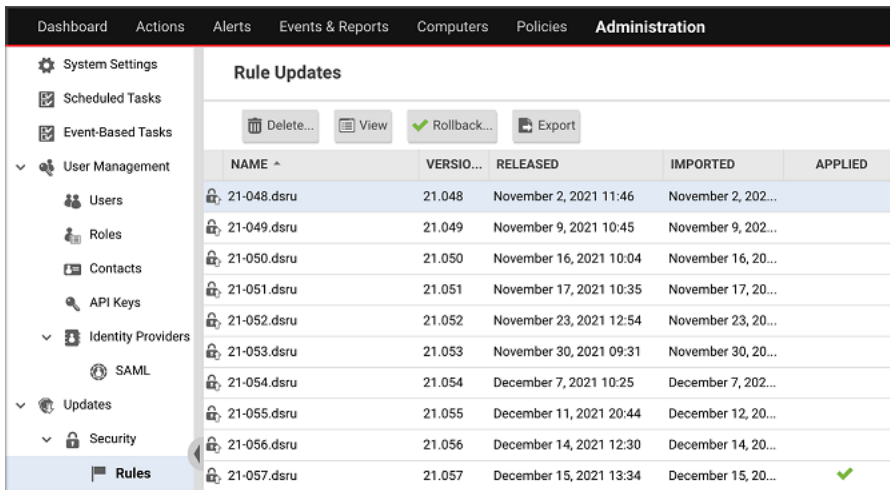

NAME ^	VERSIO...	RELEASED	IMPORTED	APPLIED
21-048.dsr	21.048	November 2, 2021 11:46	November 2, 202...	
21-049.dsr	21.049	November 9, 2021 10:45	November 9, 202...	
21-050.dsr	21.050	November 16, 2021 10:04	November 16, 20...	
21-051.dsr	21.051	November 17, 2021 10:35	November 17, 20...	
21-052.dsr	21.052	November 23, 2021 12:54	November 23, 20...	
21-053.dsr	21.053	November 30, 2021 09:31	November 30, 20...	
21-054.dsr	21.054	December 7, 2021 10:25	December 7, 202...	
21-055.dsr	21.055	December 11, 2021 20:44	December 12, 20...	
21-056.dsr	21.056	December 14, 2021 12:30	December 14, 20...	
21-057.dsr	21.057	December 15, 2021 13:34	December 15, 20...	✓

Trend Micro Deep Security On-Premise 20

General Info	
Name:	21-057.dsr
Version:	21.057
Released:	December 15, 2021 13:34
Imported:	December 15, 2021 16:27
Applied:	Yes (Current)

Contents	
The Deep Security Rule Update contains the following new or updated Intrusion Prevention Rules:	
Web Server Common	
1011242 - Apache Log4j Remote Code Execution Vulnerability (CVE-2021-44228)	

- If the rule isn't applied, [run a recommendation scan](#). We suggest that you create a 'run once' scheduled task and select the **Run Task on 'Finish'** option.

Enter a unique name for this scheduled task.

Name:	Once Only Scan Computers for Recommendations
Type:	Scan Computers for Recommendations
Schedule:	Once Only on December 17, 2021 at 13:40 (UTC-5.00)
Next Run:	December 17, 2021 13:40
Details:	All Computers

Enable Task

Run Task on 'Finish'

- To ensure that the rule gets applied wherever it's recommended, open the policy that is assigned to the computers you just scanned, go to **Intrusion Prevention > General**, and search for rule 1011242. Select the checkbox next to the rule name to assign it to the policy. All computers protected by this policy will have the rule applied to it.
- Intrusion Prevention operates in either Detect or Prevent mode. Detect mode generates events about rule violations but doesn't block traffic. Prevent mode generates events and blocks traffic that matches rules, to prevent attacks. To set Prevent mode, open the computer or policy editor, go to **Intrusion Prevention > General** and set **Intrusion Prevention Behavior** to **Prevent**. Click **Save**.

Identify potentially affected hosts

If you are also using Trend Micro Vision One, you can use the following query to identify hosts that may be affected by this vulnerability:

```
eventName:DEEP_PACKET_INSPECTION_EVENT AND (ruleId:1008610 OR ruleId:1011242 OR ruleId:1005177) AND ("${" AND ("lower:" OR "upper:" OR "sys:" OR "env:" OR "java:" OR "jndi:"))
```

Use a custom Log Inspection rule to investigate activity

Trend Micro has provided a [Log Inspection](#) rule to help identify activity related to this vulnerability:

1011241 - Apache Log4j Remote Code Execution Vulnerability (CVE-2021-44228)

You can also create a custom Log Inspection rule to detect patterns that are discovered in the future. For details, see [Custom Log Inspection Rules for Log4Shell Vulnerability on Trend Cloud One - Endpoint & Workload Security and Deep Security](#).

More resources from Trend Micro about this vulnerability

- For up to date information about how Trend Micro can help, see [Apache Log4j \(Log4Shell\) Vulnerability](#).
- We also have a [video with information about this vulnerability](#).
- For detailed information about this vulnerability and how Trend Micro can help protect your environment from attack, see [SECURITY ALERT: Apache Log4j "Log4Shell" Remote Code Execution 0-Day Vulnerability \(CVE-2021-44228\)](#).

Troubleshooting

"Offline" agent

A computer [status](#) of "Offline" or "Managed (Offline)" means that the Deep Security Manager hasn't communicated with the Deep Security Agent's instance for some time and has exceeded the missed heartbeat threshold. (See ["Configure the heartbeat" on page 1448](#).) The status change can also appear in alerts and events.

Causes

Heartbeat connections can fail because:

- The agent is installed on a workstation or other computer that has been shut down. If you are using Deep Security to protect computers that sometimes get shut down, make sure the policy assigned to those computers does not raise an alert when there is a missed heartbeat. In the policy editor, go to **Settings > General > Number of Heartbeats that can be missed before an alert is raised** and change the setting to "Unlimited".
- Firewall, IPS rules, or security groups block the heartbeat [port number](#).
- Outbound (ephemeral) ports were blocked accidentally. See ["Blocked port" on page 1376](#) for troubleshooting tips.
- Bi-directional communication is enabled, but only one direction is allowed or reliable (see ["Configure communication directionality" on page 1450](#)).
- Computer is powered off.
- Computer has left the [context](#) of the private network
This can occur if roaming endpoints (such as a laptop) cannot connect to the manager at their current location. Guest Wi-Fi, for example, often restricts open ports, and has NAT when traffic goes across the Internet.

Trend Micro Deep Security On-Premise 20

- Amazon WorkSpace computer is being powered off, and the heartbeat interval is fast, for example, one minute; in this case, wait until the WorkSpace is fully powered off, and at that point, the status should change from 'Offline' to 'VM Stopped'.
- DNS was down, or could not resolve the manager's hostname.
- The manager, the agent, or both are under very high system resource load.
- The agent process might not be running.
- Certificates for [mutual authentication](#) in the SSL or TLS connection have become invalid or revoked (see ["Replace the Deep Security Manager TLS certificate" on page 1570](#)).
- The agent's or manager's system time is incorrect (required by SSL/TLS connections).
- Deep Security [rule update](#) is not yet complete, temporarily interrupting connectivity.
- On AWS EC2, ICMP traffic is required, but is blocked.
- After upgrading to agent version 20.0.0.6313 or later, if the agent is still using SHA-1 algorithm. Now the agent only allows newer, more secure cryptographic algorithms for communication to the manager.

Tip: If you are using manager-initiated or bi-directional communication, and are having communication issues, we strongly recommend that you change to agent-initiated activation (see ["Activate and protect agents using agent-initiated activation and communication" on page 1460](#)).

To troubleshoot the error, verify that the agent is running, and then that it can communicate with the manager.

Verify that the agent is running

On the computer with the agent, verify that the Trend Micro Deep Security Agent service is running. Method varies by operating system.

- On Windows, open the Microsoft Windows Services Console (services.msc) or Task Manager. Look for the service named ds_agent.

Trend Micro Deep Security On-Premise 20

- On Linux, open a terminal and enter the command for a process listing. Look for the service named ds_agent or ds-agent, such as:

```
sudo ps -aux | grep ds_agent
```

```
sudo service ds_agent status
```

- On Solaris, open a terminal and enter the command for a process listing. Look for the service named ds_agent, such as:

```
sudo ps -ef | grep ds_agent
```

```
sudo svcs -l svc:/application/ds_agent:default
```

Verify DNS

If agents connect to the manager via its domain name or hostname, not its IP address, test the DNS resolution:

```
nslookup [manager domain name]
```

DNS service must be reliable.

If the test fails, verify that the agent is using the correct DNS proxy or server (internal domain names can't be resolved by a public DNS server such as Google or your ISP). If a name such as dsm.example.com cannot be resolved into its IP address, communication will fail, even though correct routes and firewall policies exist for the IP address.

If the computer uses DHCP, in the computer or policy settings, in the **Advanced Network Engine** area, you might need to enable **Force Allow DHCP DNS**(see "[Network engine settings](#)" on page 725).

Allow outbound ports (agent-initiated heartbeat)

Telnet to [required port numbers](#) on the manager to verify that a route exists, and the port is open:

Trend Micro Deep Security On-Premise 20

```
telnet [manager IP]:4120
```

Tip: Telnet success proves most of the same things as a ping: that a route and correct firewall policy exist, and that Ethernet frame sizes are correct. (Ping is disabled on computers that use the default security policy for the manager. Networks sometimes block ICMP ping and traceroute to block attackers' reconnaissance scans. So usually, you can't ping the manager to test.)

If telnet fails, trace the route to discover which point on the network is interrupting connectivity.

- On Linux, enter the command:

```
traceroute [agent IP]
```

- On Windows, enter the command:

```
tracert [agent IP]
```

Adjust firewall policies, routes, NAT port forwarding, or all three to correct the problem. Verify both network and host-based firewalls, such as Windows Firewall and Linux iptables. For an AWS EC2 instance, see Amazon's documentation on [Amazon EC2 Security Groups for Linux Instances](#) or [Amazon EC2 Security Groups for Windows Instances](#). For an Azure VM instance, see Microsoft's Azure documentation on [modifying a Network Security Group](#).

If connectivity tests from the agent to the manager succeed, then next you must test connectivity in the other direction. (Firewalls and routers often require policy-route pairs to allow connectivity. If only 1 of the 2 required policies or routes exist, then packets will be allowed in one direction but not the other.)

Allow inbound ports (manager-initiated heartbeat)

On the manager, ping the agent and telnet to the heartbeat port number to verify that heartbeat and configuration traffic can reach the agent:

```
ping [agent IP]
```

Trend Micro Deep Security On-Premise 20

```
telnet [agent IP]:4118
```

If the ping and telnet fail, use:

```
tracert [agent IP]
```

to discover which point on the network is interrupting connectivity. Adjust firewall policies, routes, NAT port forwarding, or all three to correct the problem.

If IPS or firewall rules are blocking the connection between the agent and the manager, then the manager cannot connect in order to unassign the policy that is causing the problem. To solve this, enter the command on the computer to reset policies on the agent:

```
dsa_control -r
```

Note: You must re-activate the agent after running this command.

Allow ICMP on Amazon AWS EC2 instances

In the AWS cloud, routers require ICMP type 3 code 4. If this traffic is blocked, connectivity between agents and the manager may be interrupted.

You can force allow this traffic in Deep Security. Either create a firewall policy with a force allow, or in the computer or policy settings, in the **Advanced Network Engine** area, enable **Force Allow ICMP type3 code4** (see "[Network engine settings](#)" on [page 725](#)).

Fix the upgrade issue on Solaris 11

A problem may occur if you previously installed Deep Security Agent 9.0 on Solaris 11, and then upgraded the agent software to 11.0 directly without first installing 9.0.0-5616 or a later 9.0 agent. In this scenario, the agent may fail to start up after the upgrade and may appear as offline in Deep Security Manager. To fix this issue:

1. Uninstall the agent from the server. See ["Uninstall Deep Security Agent" on page 1676](#).
2. Install the Deep Security Agent 11.0. See ["Install the agent manually" on page 515](#).
3. Re-activate the agent on the manager. See ["Activate the agent" on page 538](#).

High CPU usage

On a computer protected by Deep Security Agent, you can use these steps to determine and resolve the cause of high CPU usage.

1. Verify that the Trend Micro Deep Security Agent process (ds_agent.exe on Windows) has unusually high CPU usage. Method varies by operating system.

Windows: Task Manager

Linux: `top`

Solaris: `prstat`

AIX: `topas`

2. Verify that the agent is updated to the latest version.
3. Apply the best practices on ["Performance tips for anti-malware" on page 825](#) and ["Performance tips for intrusion prevention" on page 924](#).
4. If you have just enabled application control, wait until the initial baseline ruleset is complete. Time required varies by the number of files on the file system. The CPU usage should decrease.
5. If a recommendation scan is being performed, try running scans during a time when the computer is less busy, or (if the computer is a VM) allocating more vCPUs.
6. Temporarily disable each protection feature (anti-malware etc.), one at a time. Check CPU usage each time to determine if a specific module is the cause.
7. If high CPU usage still continues, try temporarily stopping the agent. Verify that the issue stops when the agent is stopped. If it does, [collect diagnostic information](#) and give it to your support provider.

Diagnose problems with agent deployment (Windows)

If a Deep Security Agent on Windows fails to install or activate, look in the deployment logs to find the cause and troubleshoot it.

1. Log in to the computer where you were trying to install the agent.
2. Go to `%appdata%\Trend Micro\Deep Security Agent\installer`.
3. Examine:
 - `dsa_deploy.txt` - Log from the PowerShell script. Contains agent activation issues.
 - `dsa_install.txt` - Log from the MSI installer. Contains agent installation issues.

"Anti-Malware Driver Offline" status with VMware

See [Anti-malware driver offline](#).

Anti-Malware Windows platform update failed

If you get a `935 Software Update: Anti-Malware Windows Platform Update Failed` error, double-click the error message to display more detailed information. The "Message" in the error event may include:

- "An incompatible Anti-Malware component from another Trend Micro product" on the next page
- "An incompatible Anti-Malware component from a third-party product" on the next page
- "The certificate is not signed by Trend Micro" on the next page
- "The signed certificate is not trusted" on page 1926

- ["The signed certificate is not authorized with appropriated purpose" on the next page](#)
- ["Other/Unknown Error" on the next page](#)

An incompatible Anti-Malware component from another Trend Micro product

To solve this error:

1. Uninstall the incompatible Trend Micro product (for example, Office Scan or Endpoint Sensor).
2. Reinstall the Deep Security Agent.

An incompatible Anti-Malware component from a third-party product

To solve this error:

1. Uninstall the third-party product.
2. Reinstall the Deep Security Agent.
3. Add Deep Security to the third-party software's exception list. Contact Trend Micro support if you need assistance.

The certificate is not signed by Trend Micro

To solve this error:

1. Update your Windows computer to support SHA-2 code signing. For details, see [New versions of Trend Micro Deep Security agents for Windows will only be signed with SHA-2](#).
2. Restart Deep Security Agent.
3. If the error is not resolved, please collect an agent diagnostic package and contact Trend Micro support for assistance.

The signed certificate is not trusted

To solve this error:

1. Follow the instructions in [Updating the VeriSign, DigiCert, USERTrust RSA certificate on Deep Security](#) to import required certificates.
2. Restart Deep Security Agent.
3. If the error is not resolved, please collect an agent diagnostic package and contact Trend Micro support for assistance.

The signed certificate is not authorized with appropriated purpose

To solve this error:

1. Follow the instruction in [Examining purpose of certificate in Deep Security](#) to enable the purpose of the certificate.
2. Restart Deep Security Agent.
3. If the error is not resolved, please collect an agent diagnostic package and contact Trend Micro support for assistance.

Other/Unknown Error

To solve this error:

1. Uninstall and reinstall the Deep Security Agent.
2. If the error is not resolved, please collect an agent diagnostic package and contact Trend Micro support for assistance.

Note: These three conditions belong to this category:

- The digital signature is not found.
- The certificate failed to be verified.
- Unexpected error occurs during certificate check.

Performance issues on an agentless virtual machine

Cause: Limited resources

1. Make sure that Deep Security Virtual Agent resource is reserved from settings.
2. Ensure that the deployment has met the requirements specified in the installation instructions.

Cause: Anti-malware

1. On Deep Security Manager, go to **Computers**.
2. Double-click the protected computer.
3. For **Anti-Malware**, select **Off**.

Cause: Network traffic

- Add scan exclusions for locations that are known to reduce performance without improving security. For details, see [Recommended scan exclusion list for Trend Micro Endpoint products in OfficeScan \(OSCE\)](#).

Note: The thin driver exclusion is case-sensitive.

Cause: Policy

- Change the policy setting for the virtual machine to **None**.

Cause: High CPU

1. Identify which Deep Security Virtual Agent has high CPU usage.
 - Go to the vCenter console, click each Deep Security Virtual Agent and select **Performance** to identify the machine with high CPU usage.
2. Run the hop tool to determine which process is consuming most of the CPU usage.
3. Identify the high CPU process memory consumption.
 - a. Execute the following to check the process memory status: `#cat /proc/$PID/status`(Replace `$PID` with your own PID.)
 - b. Verify that the `vmsize` is reasonable.
 - c. Export the content to a log file using this command:

```
#cat /proc/$PID/status > /tmp/HighCPUProcessMemory.txt
```

```
#sudo lsof -p $PID > /tmp/HighCPUProcessOpenedFile.t
```

4. Check if the Deep Security Virtual Agent has enough free memory.
 - a. Run the command `cat /proc/meminfo` to identify the Deep Security Virtual Agent system free memory.
 - b. Run the command `cat /proc/meminfo > /tmp/DSVAMemory.txt` to export the content to a log file.

Cause: Security Update

1. Check the connection between the relay and its update source or proxy server.
 - a. Verify if you need to use a proxy server or not.
 - b. Log into the Deep Security, go to **Administration > System Settings > Proxy**, and confirm that the configuration settings are correct.
2. Perform a ping test between the agent and the relay-enabled agent.
3. Make sure that the [relay port number](#) is open by using `telnet [relay IP] [port number]`.
4. Test the DNS to determine if the hostname of the relay can be resolved.

5. Check if any firewalls are blocking the communication and disable them if they are.
6. Unassign the current policy and check if the issue still persists.

Security update connectivity

Verify the connectivity between the relay server and its Active Update source or proxy server.

1. To verify that both a route exists and that the [relay port number](#) is open, enter the command:

```
telnet [relay IP] [port number]
```

If the telnet fails, verify that a route exists and that firewall policies (if any) allow the traffic by pinging or using traceroute. Also verify that the port number is open, and doesn't have a port conflict.

2. To verify that the DNS server can resolve the domain name of the relay, enter the command:

```
nslookup [relay domain name]
```

If the test fails, verify that the agent is using the correct DNS proxy or server (internal domain names can't be resolved by a public DNS server such as Google or your ISP).

3. If you use a proxy server, on Deep Security, confirm that the [proxy settings](#) are correct.
4. To determine if your Deep Security settings are blocking connectivity, unassign the current policy.

SQL Server domain authentication problems

If you experience problems connecting to the Microsoft SQL Server database when installing Deep Security Manager, follow the instructions below to troubleshoot the problem.

Note: This topic's scope is limited to Windows domain authentication issues. If you are using SQL Server Authentication instead, see "[Configure the database](#)" on page 437 and review the configuration steps listed in that topic to troubleshoot any problems.

Tip: 'Windows domain authentication' goes by many names: Kerberos authentication, domain authentication, Windows authentication, integrated authentication, and a few others. In this topic, the terms 'Kerberos' and 'Windows domain authentication' are used.

"[Step 1: Verify the host name and domain](#)" below

"[Step 2: Verify the servicePrincipalName \(SPN\)](#)" on the next page

"[Step 3: Verify the krb5.conf file \(Linux only\)](#)" on page 1945

"[Step 4: Verify the system clock](#) " on page 1947

"[Step 5: Verify the firewall](#) " on page 1947

"[Step 6: Verify the dsm.properties file](#)" on page 1948

Step 1: Verify the host name and domain

You must make sure the **Host name** field is in FQDN format and resolvable by the DNS server:

1. When you run the Deep Security Manager installer and reach the database step, make sure you specify the SQL server's FQDN. Don't input an IP address or NetBIOS host name.

Example of a valid host name: `sqlserver.example.com`

2. Make sure the FQDN is registered and resolvable by the DNS server. To check if the correct host name was configured in the DNS entry, use the `nslookup` command-line utility. This utility can be invoked from any computer on the domain. Enter the

following command:

```
nslookup <SQL_Server_FQDN>
```

where `<SQL_Server_FQDN>` is replaced with the FQDN of the SQL server. If the utility can resolve the provided FQDN successfully, then the DNS entry is configured properly. If the FQDN cannot be resolved, then configure a DNS A record and reverse record that includes the FQDN.

3. Still on the installer's database page, click **Advanced** and make sure you specify the SQL server's full domain name in the **Domain** field. The domain must include one or more dots ("."). Don't input a short domain name or NetBIOS name.

Example of a valid domain name: `example.com`

4. Check if the domain name is in FQDN format using the `nslookup` command-line utility. Enter the following command:

```
nslookup <Domain_Name>
```

where `<Domain_Name>` is replaced with the full domain name of the SQL server. If the utility can resolve the provided domain name, then it is the full domain name.

Note: Database authentication using Microsoft workgroups is not supported by Deep Security Manager 10.2 and later. For Windows domain authentication, you'll need to have installed an Active Directory domain controller, configured a domain, and added the SQL server to this domain. If there is no Active Directory domain infrastructure in your environment, you must use SQL Server Authentication instead. (To use SQL Server Authentication instead of Windows domain authentication, enter the Deep Security Manager database owner's user name and password into the **User name** and **Password** fields on the **Database** page of the manager's installer. Do not input a domain. The omission of a domain name causes SQL Server Authentication to be used. For details, see ["Install the manager" on page 443.](#))

Step 2: Verify the servicePrincipalName (SPN)

You must make sure the servicePrincipalName (SPN) is configured correctly in Active Directory.

For Microsoft SQL Server, the SPN is in this format:

```
MSSQLSvc/<SQL_Server_Endpoint_FQDN>
```

```
MSSQLSvc/<SQL_Server_Endpoint_FQDN>:<PORT>
```

To verify that the SPN is correct, run through these tasks. At the end are some step-by-step instructions for specific use cases, references to other documentation, and debugging tips.

["Step 2a: Identify the account \(SID\) running the SQL Server service" below](#)

["Step 2b: Find the account in Active Directory" on page 1934](#)

["Step 2c: Identify which FQDN to use in the SPN " on page 1935](#)

["Step 2d: Identify whether you're using a default instance or named instance " on page 1935](#)

["Case 1: Set the SPN under a local virtual account" on page 1936](#)

["Case 2: Set the SPN under a domain account" on page 1938](#)

["Case 3: Set the SPN under a Managed Service account" on page 1940](#)

["Case 4: Set the SPN for a failover cluster" on page 1942](#)

["SPN references" on page 1944](#)

["SPN debugging tips" on page 1944](#)

Step 2a: Identify the account (SID) running the SQL Server service

The SPN is configured inside the account running the SQL Server service.

To identify which account is running the SQL Server service, use the `services.msc` utility. You see the SQL Server service appear, along with the associated account.

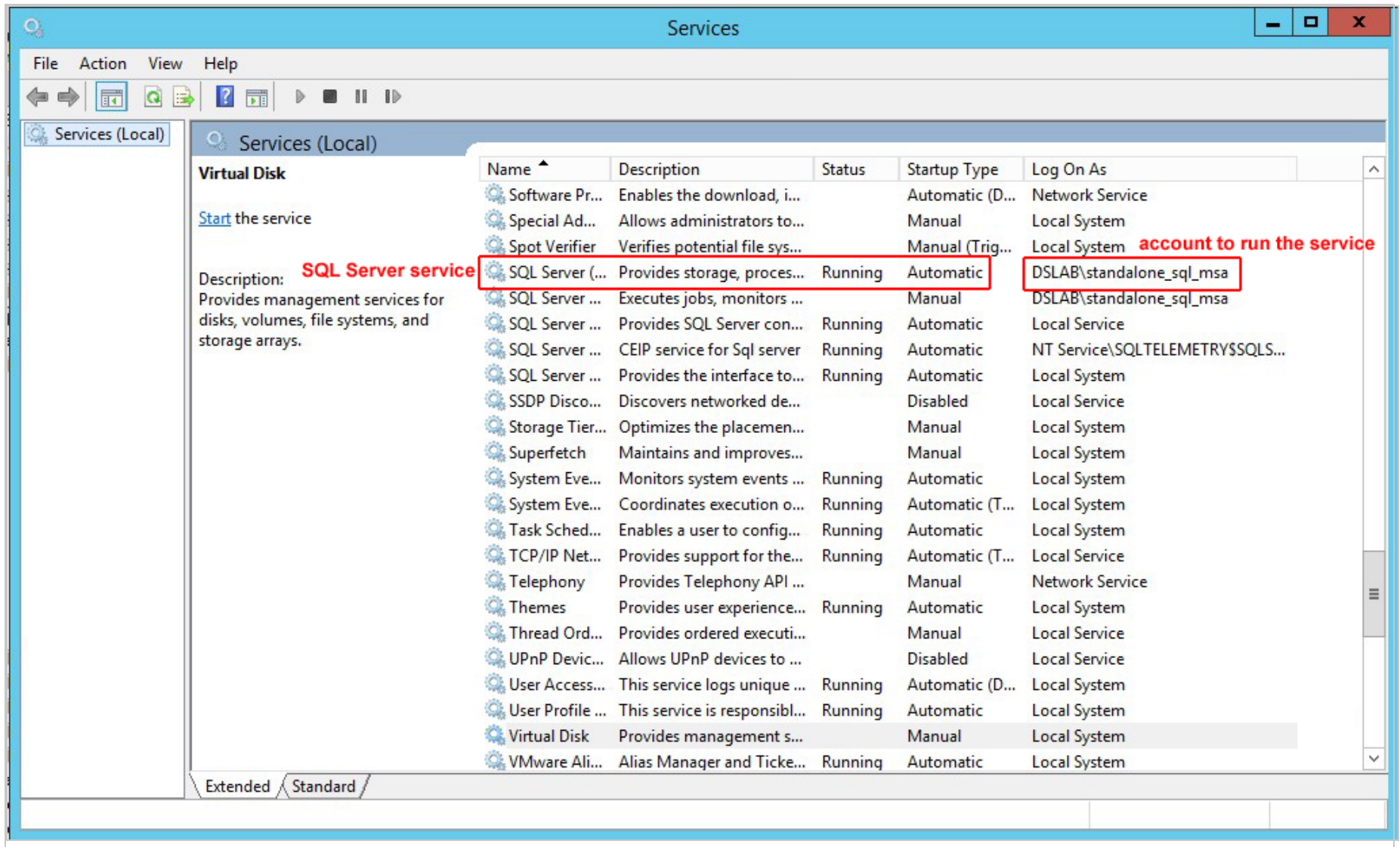

Step 2b: Find the account in Active Directory

Once you know the name of the account running the SQL Server service, you must locate it in Active Directory. The account can be in a few possible locations depending on whether it is a local virtual account, a domain account, or a Managed Service account. The table below outlines these possible locations. You can use the ADSI Editor (`adsiedit.msc`) on the Active Directory computer to look for the different folders in Active Directory and find the account.

Account type	Name of account	Location of account in Active Directory	Description
Local virtual account	NT SERVICE\MSSQLSERVER (default instance) NT SERVICE\MSSQL\$InstanceName (named instance)	CN=Computer CN=<Computer_Name>	Services that run under virtual accounts access network resources by using the credentials of the computer account. The default standalone SQL Server service uses this account to start up.
Domain account	A domain user name, for example, SQLServerServiceUser	CN=Users CN=<User_Name>	Services started using this account access the network resources using a domain user's credentials. SQL Server failover clusters require a domain account to run the service. The standalone SQL Server service can also be configured to use a domain account to start up.
Managed Service account	A Managed Service account name, for example SQLServerMSA	CN=Managed Service Account CN=<Account_Name>	Introduced in Windows Server 2008 R2, the Managed Service Account resembles the domain account, but can be used to perform interactive logons. Both the standalone SQL Server service and the SQL Server cluster services can be configured to use a Managed Service account to start up.

Step 2c: Identify which FQDN to use in the SPN

For naming consistency, it is recommended that you set the SPN to the FQDN of the endpoint. The endpoint is the target to which the SQL Server client (Deep Security Manager) connects, and may be an individual SQL Server or a cluster. Consult the table below for details on which FQDN to use.

If the SQL Server installation type is...	Set the SPN to...
Standalone SQL Server	The FQDN of the host where the SQL Server is installed
Failover SQL Server cluster	The FQDN of the SQL Server cluster (individual SQL Server nodes are not the endpoint and should not be used in the FQDN)

Step 2d: Identify whether you're using a default instance or named instance

You must know whether the SQL Server was installed as a default instance or a named instance because the port number and instance name (if one was specified) need to go into the SPN.

- The default instance typically uses port 1433.
- A named instance uses a different port. To determine this port, consult [this webpage](#).

Example: If the FQDN endpoint of the SQL Server service is `sqlserver.example.com` and it is the default instance, then the SPN will be in the format:

```
MSSQLSvc/sqlserver.example.com
```

```
MSSQLSvc/sqlserver.example.com:1433
```

Another example: If the FQDN endpoint of SQL Server service is `sqlserver.example.com` and it is a named instance using port 51635 with an instance name of `DEEPSECURITY`, then the SPN will be in the format:

```
MSSQLSvc/sqlserver.example.com:DEEPSECURITY
```

```
MSSQLSvc/sqlserver.example.com:51635
```

Case 1: Set the SPN under a local virtual account

To set the SPN for a standalone SQL Server that runs under a local virtual account:

1. On the Active Directory computer, open `ADSIEdit.msc`. The ADSI Editor opens.
2. Locate the SQL Server host in **CN=Computers**.
3. Right-click the SQL Server host, and select **Properties**.
4. On the **Attribute Editor** tab, scroll to **servicePrincipalNames** and click the **Edit** button.
5. If the attribute values don't exist, add each one individually using the **Add** button. Click **OK**.

ADSI Edit

File Action View Help

DC=ad,DC=dslab

- CN=Builtin
- CN=Computers
- CN=DIOWIN2016
- CN=MSSQLSRV** **SQL Server Host**
- OU=Domain Controllers
- CN=ForeignSecurityPrincipals
- CN=LostAndFound
- CN=Managed Service Accounts
- CN=NTDS Quotas
- CN=Program Data
- CN=System
- CN=TPM Devices
- CN=Users

Attribute Editor Security

Attributes:

Attribute	Value
sAMAccountName	MSSQLSRV\$
sAMAccountType	805306369 = (MACHINE_ACCOUNT)
scriptPath	<not set>
secretary	<not set>
securityIdentifier	<not set>
seeAlso	<not set>
serialNumber	<not set>
servicePrincipalName	TERMSRV/MSSQLSRV; TERMSRV/MSSG
shadowExpire	<not set>
shadowFlag	<not set>
shadowInactive	<not set>
shadowLastChange	<not set>
shadowMax	<not set>
shadowMin	<not set>

Edit Filter

OK Cancel Apply Help

Case 2: Set the SPN under a domain account

The SPN configuration is similar to the local virtual account configuration except that the SPN is set in domain account (**CN=Users**) running the SQL Server service.

ADSI Edit

File Action View Help

ADSI Edit

- Default naming context [DIO-ADC.dslab.com]
 - DC=dslab,DC=com
 - CN=Builtin
 - CN=Computers
 - OU=Domain Controllers
 - CN=ForeignSecurityPrincipals
 - CN=LostAndFound
 - CN=Managed Service Accounts
 - CN=NTDS Quotas
 - CN=Program Data
 - CN=System
 - CN=TPM Devices
 - CN=Users**
 - CN=ADFS ServiceAccount
 - CN=Administrator
 - CN=Allowed RODC Password Replicat
 - CN=Cert Publishers
 - CN=Cloneable Domain Controllers
 - CN=Denied RODC Password Replicat
 - CN=DnsAdmins
 - CN=DnsUpdateProxy
 - CN=Domain Admins
 - CN=Domain Computers
 - CN=Domain Controllers
 - CN=Domain Guests

ADSI Edit

Name	Class	Distinguished Name
CN=SQLServerServiceUser Properties		
Attribute Editor Security		
Attributes:		
Attribute	Value	
sAMAccountName	sqlserver	
sAMAccountType	805306368 = (NORMAL_USER_ACCOUNT	
scriptPath	<not set>	
secretary	<not set>	
securityIdentifier	<not set>	
seeAlso	<not set>	
serialNumber	<not set>	
servicePrincipalName	MSSQLSvc/SQL2012.dslab.com:1433; MSS	
shadowExpire	<not set>	
shadowFlag	<not set>	
shadowInactive	<not set>	
shadowLastChange	<not set>	
shadowMax	<not set>	
shadowMin	<not set>	

Edit Filter

OK Cancel Apply Help

Case 3: Set the SPN under a Managed Service account

The SPN is set in the Managed Service account (**CN=Managed Service Account**) running the SQL Server service.

The screenshot shows the ADSI Edit application window. The left pane displays a tree view of the Active Directory structure. The right pane shows the properties of the selected object, 'CN=SQLServerMSA'. A red box highlights the 'CN=Managed Service Accounts' folder in the tree, and another red box highlights the 'servicePrincipalName' attribute in the properties window. A red text annotation reads 'Managed Service Account running SQL Server'.

ADSI Edit

File Action View Help

DC=dslab,DC=com

- CN=Builtin
- CN=Computers
- OU=Domain Controllers
- CN=ForeignSecurityPrincipals
- CN=LostAndFound
- CN=Managed Service Accounts**
 - CN=SQLServerMSA**
 - CN=StandaloneSQL StandaloneSC
- CN=NTDS Quotas
- CN=Program Data
- CN=System
- CN=TPM Devices
- CN=Users
 - CN=ADFS ServiceAccount
 - CN=Administrator
 - CN=Allowed RODC Password Rep
 - CN=Cert Publishers
 - CN=Cloneable Domain Controller
 - CN=Denied RODC Password Repli
 - CN=DnsAdmins
 - CN=DnsUpdateProxy
 - CN=Domain Admins
 - CN=Domain Computers

CN=SQLServerMSA Properties

Attribute Editor Security

Attributes:

Attribute	Value
secretary	<not set>
securityIdentifier	<not set>
seeAlso	<not set>
serialNumber	<not set>
servicePrincipalName	MSSQLSvc/SQLServer.dslab.com; MSSQLS
shadowExpire	<not set>
shadowFlag	<not set>
shadowInactive	<not set>
shadowLastChange	<not set>
shadowMax	<not set>
shadowMin	<not set>
shadowWarning	<not set>
showInAddressBook	<not set>
showInAdvancedVie...	<not set>

Managed Service Account running SQL Server

Case 4: Set the SPN for a failover cluster

An SQL Server failover cluster can run under a domain account or a Managed Service account. Refer to ["Case 2: Set the SPN under a domain account" on page 1938](#) or ["Case 3: Set the SPN under a Managed Service account" on page 1940](#) for instructions. Make sure to set the SPN to the FQDN of the SQL *cluster* endpoint, not an individual SQL node.

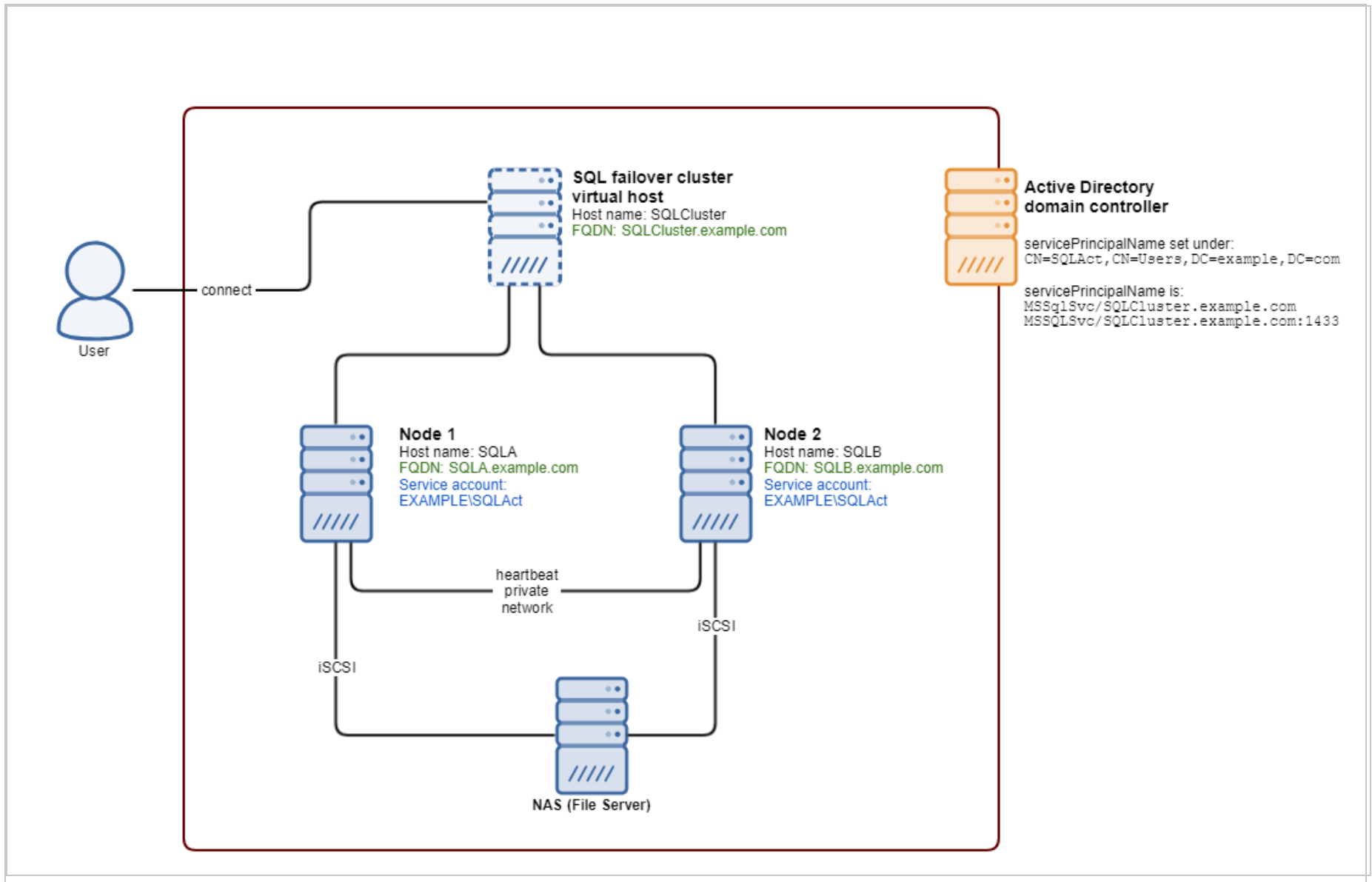

SPN references

Below are links to Microsoft's official documents about SPN configurations:

[Register a Service Principal Name for Kerberos Connections](#)

[How to: Enable Kerberos Authentication on a SQL Server Failover Cluster](#)

SPN debugging tips

To verify that the correct SPN configuration was set, use the command line tool `setspn` to query for registered SPN entries. The command syntax is:

```
setspn -T <Full_Domain_Name> -F -Q MSSQLSvc/<SQL_Server_Endpoint_FQDN>*
```

where:

- `<Full_Domain_Name>` is replaced with the domain name of your environment.
- `<SQL_Server_Endpoint_FQDN>` is replaced with the FQDN of SQL Server.

For example: Assume that a standalone SQL Server resides at `SQL2012.dslab.com`, and runs under a local virtual account in the domain `dslab.com`. You can use command below to query all registered SPNs that have a prefix of `MSSQLSvc/SQL2012.dslab.com` and see if it is correctly configured.

```

Administrator: Command Prompt

C:\Users\Administrator>setspn -T DSLAB.com -F -Q MSSQLSvc/SQL2012.dslab.com*
Checking forest DC=dslab.DC=com
CN= SQL2012, CN=Computers, DC=dslab, DC=com
    MSSQLSvc/SQL2012.dslab.com:1433
    MSSQLSvc/SQL2012.dslab.com

Existing SPN found!
  
```

SPN entry is found in CN of host (computer) providing the service

From the command result, you can then verify that the SPN has been set and registered in correct LDAP path, and in the account that is running the SQL Server service (in this case, it is the computer account).

Step 3: Verify the krb5.conf file (Linux only)

If you're installing the manager on Linux, you must make sure the `/etc/krb5.conf` exists and contains the correct domain and realm information:

1. Open or create the `/etc/krb5.conf` file in a text editor to configure Kerberos.
2. Provide the following information:

```

[libdefaults]
...
default_realm = <DOMAIN>
...

[realms]
<DOMAIN> = {
    kdc = <ACTIVE_DIRECTORY_CONTROLLER_FQDN>
  
```

Trend Micro Deep Security On-Premise 20

```
admin_server = <ACTIVE_DIRECTORY_CONTROLLER_FQDN>
}
[domain_realm]
.<DOMAIN FQDN> = <DOMAIN>
<DOMAIN FQDN> = <DOMAIN>
```

where <DOMAIN>, <ACTIVE_DIRECTORY_CONTROLLER_FQDN> and <DOMAIN_FQDN> are replaced with your own values.

Example file:

```
[libdefaults]
default_realm = EXAMPLE.COM
default_tkt_enctypes = des3-hmac-sha1 des-cbc-crc
default_tgs_enctypes = des3-hmac-sha1 des-cbc-crc
dns_lookup_kdc = true
dns_lookup_realm = false

[realms]
EXAMPLE.COM = {
kdc = kerberos.example.com
kdc = kerberos-1.example.com
admin_server = kerberos.example.com
```

```
}  
  
[domain_realm]  
    .example.com = EXAMPLE.COM  
    example.com = EXAMPLE.COM  
  
[logging]  
    kdc = SYSLOG:INFO  
    admin_server = FILE=/var/kadm5.log
```

3. Save and close the file.

Step 4: Verify the system clock

You must make sure the system clocks on the domain controller, SQL Server, and Deep Security Manager computer are synchronized. With Kerberos, the maximum allowable clock skew is five minutes by default.

Step 5: Verify the firewall

You must make sure the firewall is not blocking the SQL connection. A default SQL Server instance allows connections through port 1433, while a named SQL Server instance uses a port that is selected at random. To find out which port to connect to, the SQL client (Deep Security Manager in this case) queries the available named instances and finds the mapping port by issuing a lookup request to the SQL Server browser service. The SQL Server browser service runs on port 1434 (UDP). Verify that your firewall configuration allows port 1433 (if you're using a default instance), or 1434 (if you're using a named instance).

Step 6: Verify the dsm.properties file

Make sure the `dsm.properties` file is configured correctly.

1. Open the `dsm.properties` file in a text editor. On Windows, the file is typically located in `C:\Program Files\Trend Micro\Deep Security Manager\webclient\webapps\ROOT\WEB-INF`.
2. Ensure that the file contains these lines:

```
database.SqlServer.server=YOUR-SERVER.EXAMPLE.COM //Include the domain name, which must use capital letters.
```

```
database.SqlServer.trustServerCertificate=true //This line is required when SQL server enables force encrypt.
```

```
database.SqlServer.domain=EXAMPLE.COM //Domain name must use capital characters.
```

```
database.SqlServer.user=sqlUser@EXAMPLE.COM //The username must include the domain name, and the domain name must use capital letters.
```

```
database.SqlServer.integratedSecurity=true
```

```
database.SqlServer.authenticationScheme=JavaKerberos
```

```
database.directory=null
```

```
database.SqlServer.namedPipe=false
```

3. Make any changes required and save the file.

Prevent MTU-related agent communication issues across Amazon Virtual Private Clouds (VPC)

Agents in different VPCs might experience problems when trying to communicate with Deep Security Manager. This could be because the network [maximum transmission unit \(MTU\)](#) supported by Amazon Web Services is 1500 and Deep Security Agent communication traffic can exceed this, which results in fragmented and dropped packets.

You can prevent this MTU-related communication issue from happening by adding a new firewall rule to all firewall policies. The key settings for this new firewall rule are shown in the image below.

General | Options | Assigned To

General Information

Name:

Description:

Action: Not

Priority: Not

Packet direction: Not

Frame Type: Not

Protocol: Not

Packet Source

IP: Not

MAC: Not

Port: Not

Packet Destination

IP: Not

MAC: Not

Port: Not

Specific Flags

Create a diagnostic package and logs

To diagnose an issue, your support provider may ask you to send a diagnostic package containing debug information for either or both:

- [Deep Security Manager](#)
- [Deep Security Agent](#)

Deep Security Manager diagnostics

Create a diagnostic package for Deep Security Manager

1. Go to **Administration > System Information**.
2. Click **Create Diagnostic Package**.

The package will take several minutes to create. After the package has been generated, a summary will be displayed and your browser will download a ZIP file containing the diagnostic package.

Enable debug logs for Deep Security Manager

In addition to a diagnostic package, your support provider may ask you to enable diagnostic logging.

Warning: Don't enable diagnostic logging unless recommended by your support provider. Diagnostic logging can consume large amounts of disk space and increase CPU usage.

1. Go to **Administration > System Information**.
2. Click **Diagnostic Logging**.

3. In the wizard that appears, select the options requested by your support provider.

If you have a multi-tenant Deep Security Manager, and the issue that you want to diagnose only occurs with a specific tenant, select that tenant's name in the option that appears. This will focus the debug logs, and minimize performance impacts while debug logging is enabled.

Some features need more time and disk space to collect enough debug logs. For example, you might need to increase **Maximum log file size** to 25 MB and the time period to 24 hours for **Database-related Issues** and **Cloud Account Synchronization - AWS**.

Note: If you decrease **Maximum number of log files**, Deep Security Manager does not automatically delete existing log files that now exceed the maximum. For example, if you reduce from 10 to 5 log files, `server5.log` to `server9.log` would all still exist. To reclaim disk space, manually delete those files from the file system.

While diagnostic logging is running, Deep Security Manager will display the message **Diagnostic Logging enabled** on the status bar. If you changed the default options, the status bar will display the message **Non default logging enabled** upon diagnostic logging completion.

4. To find diagnostic logging files, go to the root directory of the Deep Security Manager, and look for file names with the pattern `server#.log`, such as `server0.log`.

Deep Security Agent diagnostics

For an agent, you can create a diagnostic package either:

- via the Deep Security Manager
- using the CLI on a protected computer (if the Deep Security Manager cannot reach the agent remotely)

For Linux-specific information on increasing or decreasing the anti-malware debug logging for the diagnostic package, see ["Increase debug logging for anti-malware in protected Linux instances" on page 871](#).

Your support provider may also ask you collect:

- a screenshot of Task Manager (Windows) or output from `top` (Linux) or `prstat` (Solaris) or `topas` (AIX)
- [debug logs](#)
- [Perfmon log](#) (Windows) or Syslog
- [memory dumps](#) (Windows) or core dumps (Linux, [Solaris](#), [AIX](#))

Create an agent diagnostic package via Deep Security Manager

Note: Deep Security Manager must be able to connect to an agent remotely to create a diagnostic package for it. If the Deep Security Manager cannot reach the agent remotely, or if the agent is using agent-initiated activation, you must create the diagnostic package directly from the agent.

1. Go to **Computers**.
2. Double-click the name of the computer you want to generate the diagnostic package for.
3. Select the **Actions** tab.
4. Under **Support**, click **Create Diagnostics Package**.
5. Click **Next**.

The package will take several minutes to create. After the package has been generated, a summary will be displayed and your browser will download a ZIP file containing the diagnostic package.

Note: When the **System Information** check box is selected, it might create a huge diagnostic package that could have a negative impact on performance. The check box is greyed out if you are not a primary tenant or do not have the proper viewing rights.

Create an agent diagnostic package via CLI on a protected computer

Linux, AIX, and Solaris

1. Connect to the server that you want to generate the diagnostic package for.
2. Enter the command:

```
sudo /opt/ds_agent/dsa_control -d
```

The output shows the name and location of the diagnostic package: `/var/opt/ds_agent/diag`

Windows

1. Connect to the computer that you want to generate the diagnostic package for.
2. Open a command prompt as an administrator, and enter the command.

In PowerShell:

```
& "& "\Program Files\Trend Micro\Deep Security Agent\dsa_control" -d
```

In cmd.exe:

```
cd C:\Program Files\Trend Micro\Deep Security Agent
```

```
dsa_control.cmd -d
```

The output shows the name and location of the diagnostic package: `C:\ProgramData\Trend Micro\Deep Security Agent\diag`

Collect debug logs with DebugView

On Windows computers, you can collect debug logs using DebugView software.

Warning: Only collect debug logs if your support provider asks for them. During debug logging, CPU usage will increase, which will make high CPU usage issues worse.

1. Download the [DebugView utility](#).
2. If self-protection is enabled, disable it.
3. Stop the Trend Micro Deep Security Agent service.
4. In the C:\Windows directory, create a plain text file named ds_agent.ini.
5. In the ds_agent.ini file, add this line:

```
trace=*
```

6. Launch DebugView.exe.
7. Go to **Menu > Capture**.
8. Enable these settings:
 - **Capture Win32**
 - **Capture Kernel**
 - **Capture Events**
9. Start the Trend Micro Deep Security Agent service.
10. Export the information in DebugView to a CSV file.
11. Re-enable self-protection if you disabled it at the beginning of this procedure.

Increase verbose diagnostic package process memory

In environments with a large number of hosts (for example, 10,000 hosts or more,) the verbose diagnostic package process (`dsm_c.exe`) may run out of memory while creating the diagnostic package. To prevent this, you can increase the memory allocated to the verbose diagnostic package JVM process to 2 GB.

Trend Micro Deep Security On-Premise 20

1. Go to the Deep Security Manager installation directory.
2. Create a new file with the name "dsm_c.voptions".
3. Open the file and add the line `-Xmx2g`.

Note: If 2 GB of memory is not enough, you can further increase the allocated memory by changing the value in the above line (for example, `-Xmx4g` for 4 GB or `-Xmx6g` for 6 GB).

4. Save the file and run `dsm_c.exe`.

Removal of older software versions

In certain situations, we may determine that it's in the best interest of our customers to remove access to a previously released version of software. We only remove software when there is a significant known issue with that release. This is done to limit customer exposure to known problems.

When access to an old software version has been removed, the download link is replaced with a link to a Knowledge Base article detailing the issue that caused us to remove the software.

If you require access to an older version that has been removed, contact support with the software version and Knowledge Base number.

Troubleshoot SELinux alerts

To check if SELinux is enabled, use the `sestatus` command.

SELinux blocks the Deep Security Agent service

When the SELinux policy is set to enable and it blocks the Deep Security Agent service, the following alert sample might appear in the system audit log `/var/log/audit/audit.log` or SELinux log `/var/log/audit.log`:

```
[TIMESTAMP] [HOSTNAME] python: SELinux is preventing [/PATH/BINARY] from 'read, write' accesses on the file /var/opt/ds_agent/dsa_core/ds_agent.db-shm.
```

```
***** Plugin leaks (86.2 confidence) suggests *****
```

If you want to ignore [BINARY] trying to read write access the ds_agent.db-shm file because you believe it should not need this access. Then you should report this as a bug.

You can generate a local policy module to dontaudit this access.

Do

```
ausearch -x [/PATH/BINARY] --raw | audit2allow -D -M [POLICYNAME]
```

```
semodule -i POLICYNAME.pp
```

To resolve the issue, create a custom SELinux policy with Audit2allow, as follows:

1. Connect to the Deep Security Agent system as a root user.
2. Run the following commands to create a custom policy that will allow access to Deep Security Agent files:

```
cd /tmp  
grep ds_agent /var/log/audit/audit* | audit2allow -M ds_agent  
semodule -i ds_agent.pp
```

3. Restart the `ds_agent` service.
4. Execute the following command to check the system messages and confirm that there are no alerts related to `ds_agent`.

Trend Micro Deep Security On-Premise 20

```
cat /var/log/messages | grep ds_agent
```

5. If alerts still occur, rerun the commands from step 2 to update and reapply the existing policy.

To remove the SELinux policy, use the following command:

```
semodule -r ds_agent.
```

Berkeley Packet Filter (BPF) operations blocked

This issue can occur under the following conditions:

- The agent OS is Red Hat Enterprise Linux 7 (64-bit).
- SELinux is enabled in enforcing mode.
- The [Advanced TLS Traffic Inspection feature](#) is enabled on the agent.

An alert similar to the following might appear in the system audit log `/var/log/audit/audit.log` or SELinux log

`/var/log/audit.log`:

```
type=AVC msg=audit(1682773485.952:1080): avc: denied { map_create } for pid=12807 comm="ds_nuagent" scontext=system_u:system_r:unconfined_service_t:s0 tcontext=system_u:system_r:unconfined_service_t:s0 tclass=bpf permissive=0

type=SYSCALL msg=audit(1682773485.952:1080): arch=c000003e syscall=321 success=no exit=-13 a0=0 a1=c000a25800 a2=2c a3=0 items=0 ppid=12802 pid=12807 auid=4294967295 uid=0 gid=0 euid=0 suid=0 fsuid=0 egid=0 sgid=0 fsgid=0 tty=(none) ses=4294967295 comm="ds_nuagent" exe="/opt/ds_agent/nuagent/ds_nuagent" subj=system_u:system_r:unconfined_service_t:s0 key=(null)
```

To resolve the issue, follow these steps to create a custom SELinux policy:

1. Connect to the Deep Security Agent system as a root user.
2. Create a Type Enforcement file named `nuagent.te`:

```
module nuagent 1.0;
```

```
require {  
    type unconfined_service_t;  
    class bpf { map_create map_read map_write prog_load prog_run };  
}  
#===== unconfined_service_t =====  
allow unconfined_service_t self:bpf { map_create map_read map_write prog_load prog_run };
```

3. Run the following commands to create a custom policy that allows bpf access for `ds_nuagent`:

```
checkmodule -M -m -o nuagent.mod nuagent.te  
semodule_package -o nuagent.pp -m nuagent.mod  
semodule -i nuagent.pp
```

4. Restart the `ds_agent` service.

Note that Deep Security Agent version 20.0.0-8137+ added support for a new process called `tm_netagent`. The `ds_nuagent` process is still supported and the process names can be used interchangeably.

Troubleshoot Azure Code Signing

Since Microsoft Windows Agent components are now signed with [Azure Code Signing \(ACS\)](#), computers running earlier versions of Windows need to be updated with the [Microsoft KB5022661](#) patch to be able to identify Azure Code Signing certificates. If this patch has not been applied, the Deep Security Agent installation or upgrade is expected to fail and the Deep Security Manager will display a warning to that effect.

The following is a part of the Deep Security Agent log produced during a failed upgrade:

```
MSI (s) (E8:24) [01:16:53:747]: Executing op: ActionStart(Name=_ACSVerification,,)
MSI (s) (E8:24) [01:16:53:747]: Executing op:
CustomActionSchedule(Action=_ACSVerification,ActionType=1025,Source=BinaryData,Target=ACS
Verification,CustomActionData=C:\Program Files\Trend Micro\Deep Security Agent\
MSI (s) (E8:B0) [01:16:53:747]: Invoking remote custom action. DLL: C:\Windows\Installer
\MSIFC3A.tmp, Entrypoint: ACSVerification
ds_agent [01:16:53:763]: Azure Code Sign Verification Begin ...
ds_agent [01:16:53:763]: Installation property TARGETDIR is C:\Program Files\Trend
Micro\Deep Security Agent\
ds_agent [01:17:05:616]: Azure Code Sign (ACS) Verification Failed (error: 0x577). The KB
for ACS is probably required.
CustomAction _ACSVerification returned actual error code 1603 (note this may not be 100%
accurate if translation happened inside sandbox)
Action ended 1:17:05: InstallFinalize. Return value 3.
```

The following is a part of the Deep Security Manager system event log produced during a failed upgrade:

```
After 2023/2/18, agent components on Windows will use Azure Code Signing. If you use an
older Windows version, then you must apply the patch in Microsoft KB5022661 so that
Windows can validate the certificate. Agent installations and upgrades will fail if you
do not apply the update. Consult the install log for the running process:
```

For more information, see [Trend Micro Server and Endpoint Protection Agent minimum Windows version requirements for updated binaries after February 2023](#).

Network Engine Status (Windows OS)

Network Engine Status warnings

Network Engine Status warnings are a collection of warnings and errors that might appear in the [Status area](#) of a computer when the agent raises an event about the Trend Micro LightWeight Filter Driver and the [Network Engine Status Check](#) is enabled.

If you receive one of the following warnings, the network functionality might be disabled or impaired on the agent:

- Web Reputation Engine Disabled
- Firewall Engine Disabled
- Intrusion Prevention Engine Disabled
- Web Reputation Engine Working With Limited Functionality
- Firewall Engine Working With Limited Functionality
- Intrusion Prevention Engine Working With Limited Functionality

Agents display more security events for each affected network interface. See [Driver-Related Events](#) for more information.

Verify the driver status

You can verify the driver status as follows:

1. Open **Control Panel > Network and Internet > Network and Sharing Center**.
2. Select **Change adapter settings** on the left to open **Network Connections**.
3. Right-click each active network adapter and select **Properties**.
4. Verify that **Trend Micro LightWeight Filter Driver** is selected.

Disable Network Engine Status warnings

You can disable Network Engine Status warnings as follows:

1. On Deep Security Manager, navigate to **Computers**.
2. Select the computer for which you want to disable the warning, and then click **Details**.
3. In the computer details, navigate to **Settings > Advanced > Network Engine Settings**.
4. For **Network Engine Status Check**, select **Disabled**.

PDFs

Deep Security Administration Guide

The Deep Security Administration Guide is a PDF version of the Deep Security Help Center:

[Open the Deep Security 20 Administration Guide](#)

Deep Security Best Practice Guide

The Deep Security Best Practice Guide is intended to help you get the best productivity out of the product. It contains a collection of best practices that are based on knowledge gathered from previous enterprise deployments, lab validations, and lessons learned in the field. Examples and considerations in this document serve only as a guide and not a representation of strict design requirements. These guidelines do not apply in every environment but will help guide you through the decisions that you need in configuring Deep Security for optimum performance.

The Deep Security 20 Best Practice Guide is currently [available in PDF format](#) and includes the following:

Trend Micro Deep Security On-Premise 20

- Deployment considerations and recommendations
- Upgrade guidelines and scenarios
- Sizing considerations and recommendations
- Recommended configurations to maximize system performance and reduce administrative overhead
- Best practice tips for VDI, private, and public cloud environments